

LEGO[®]



8638



1

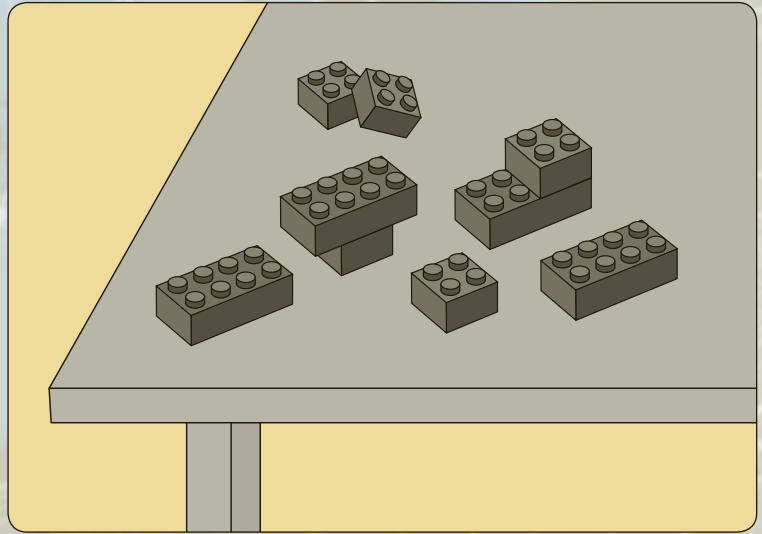
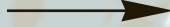
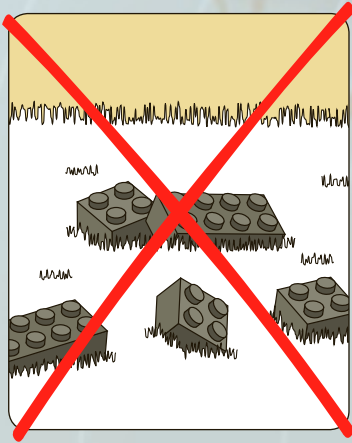

2



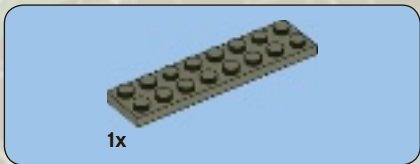
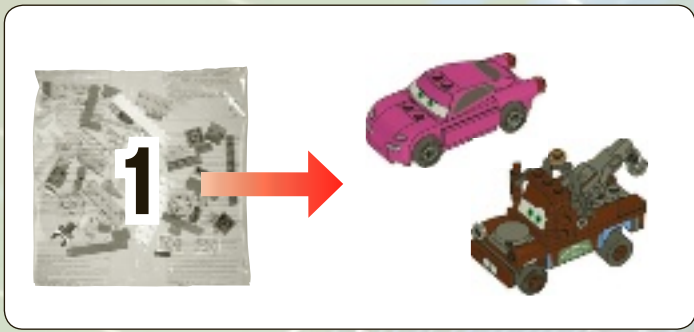

1



2



3

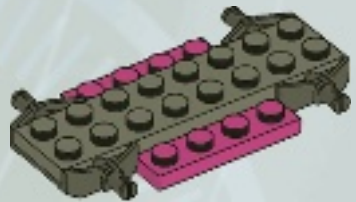



4

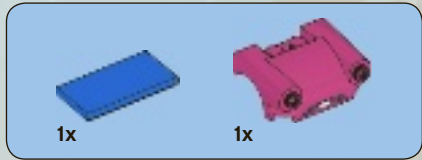
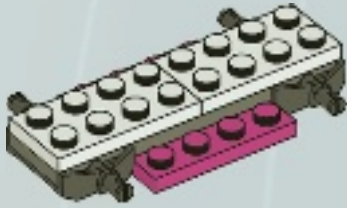

5

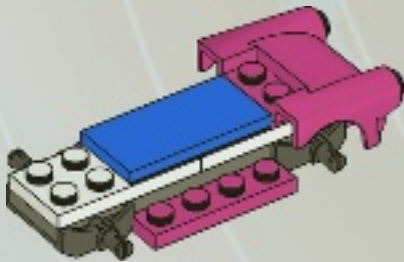

4



6

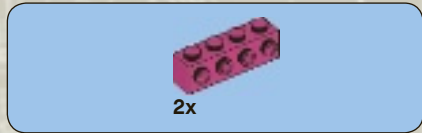
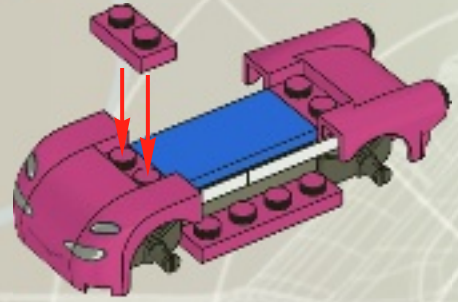

7

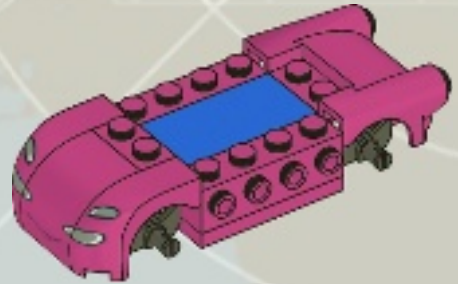

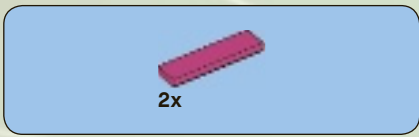

8

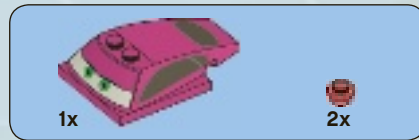
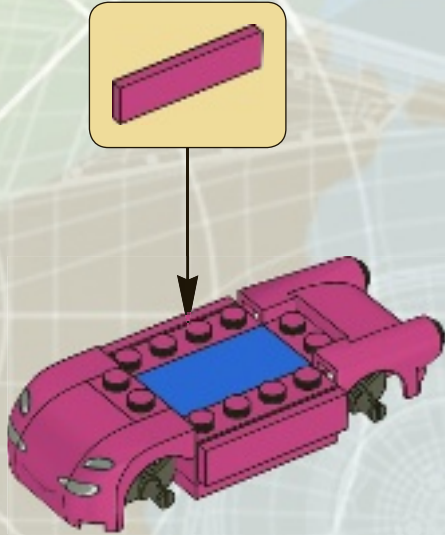

9

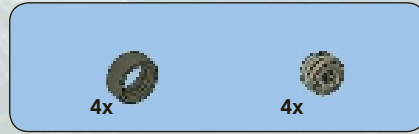

10



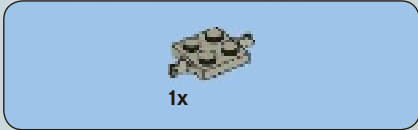

1

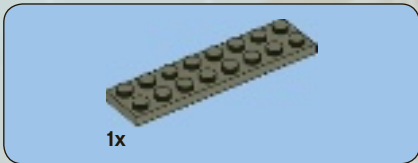

2

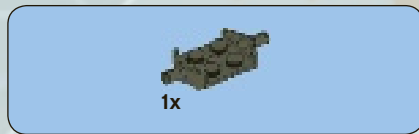
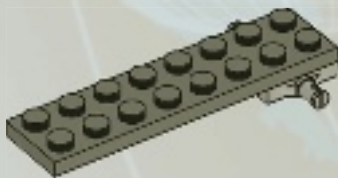

3

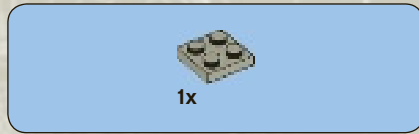

4



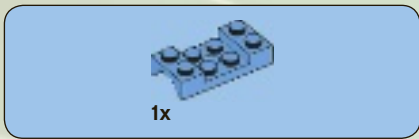

5

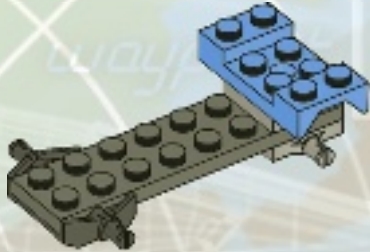

6

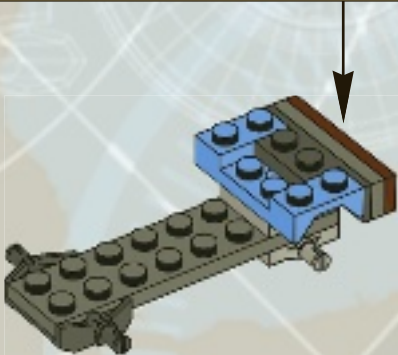
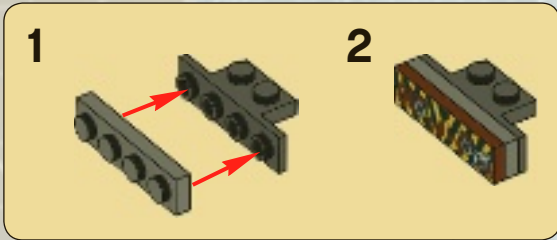

7



8

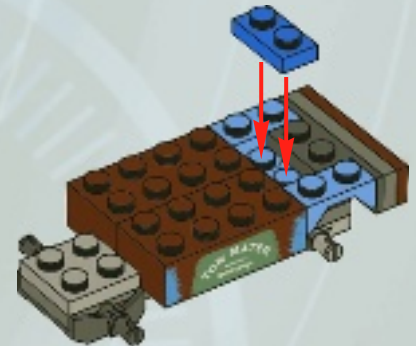

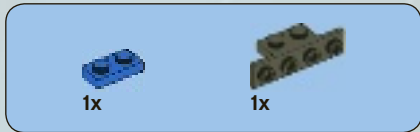

9

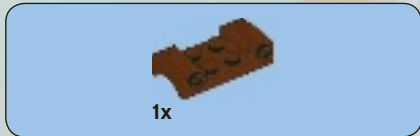

10

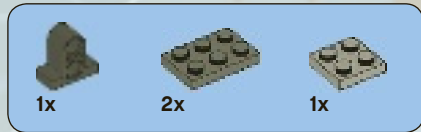

11

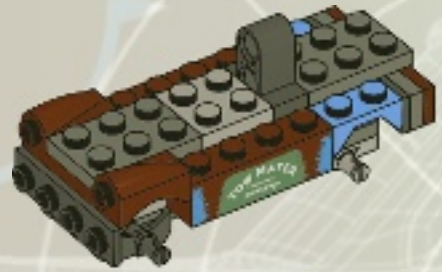

12

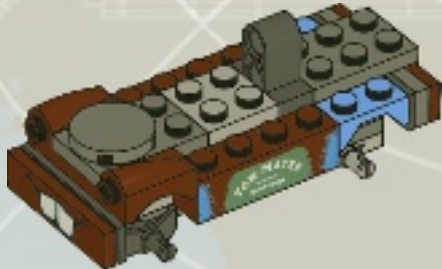



13

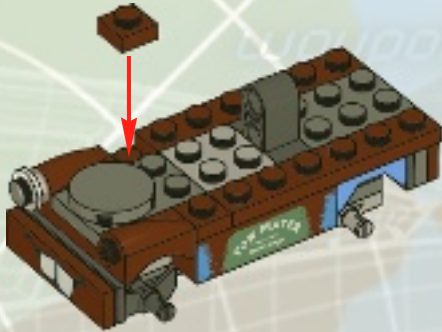

14

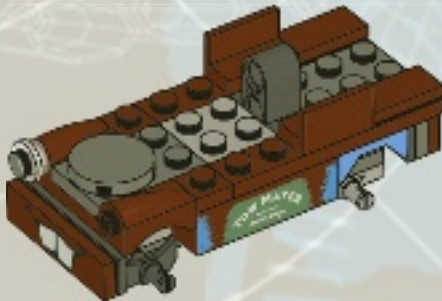

15

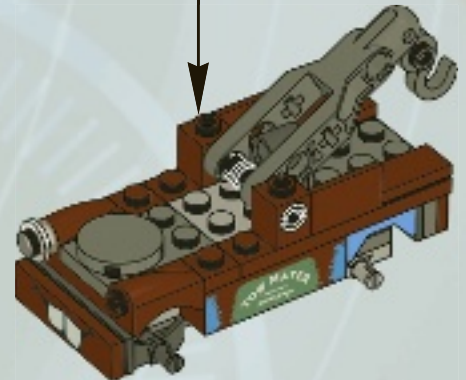
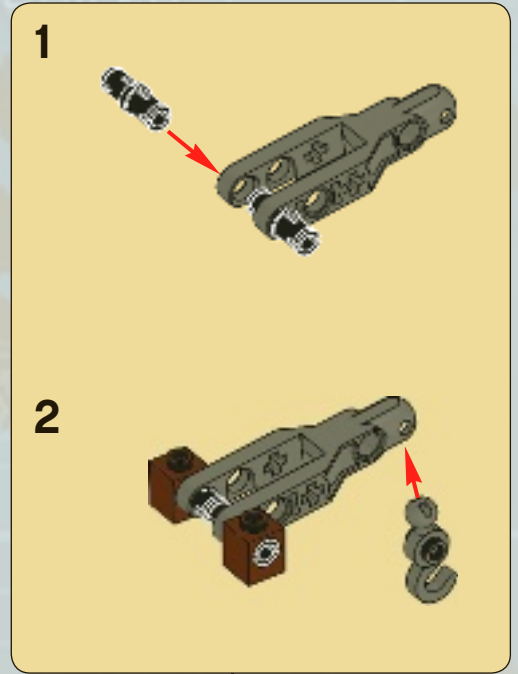



1x

16

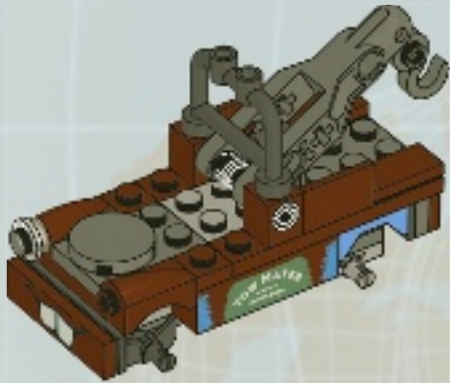

2x

17





2x

18

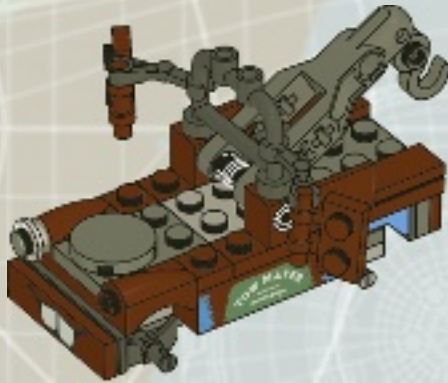

1x

19

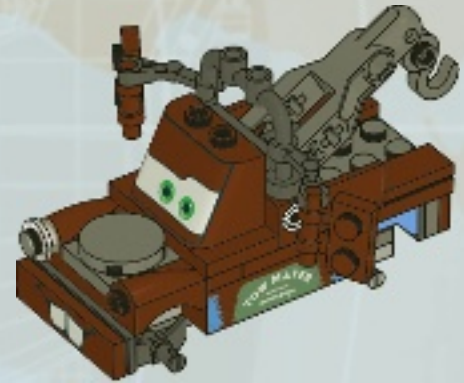



20



21

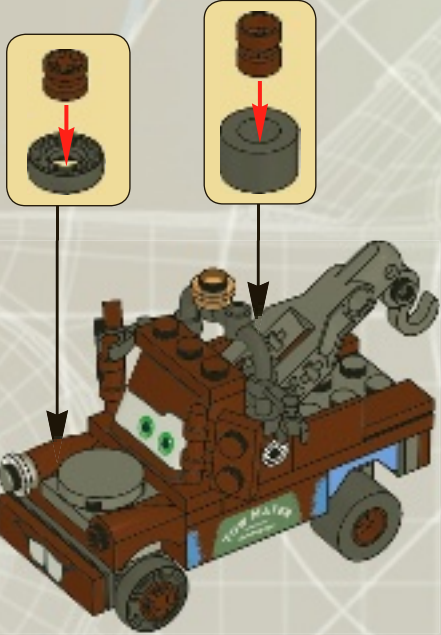

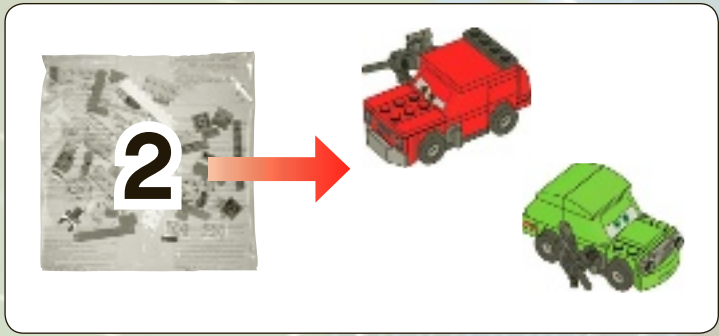

1



2

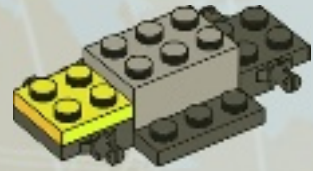

3

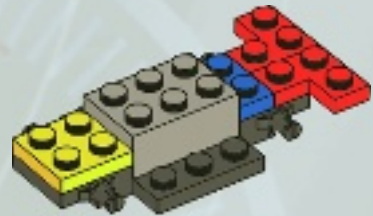



2x



2x

4

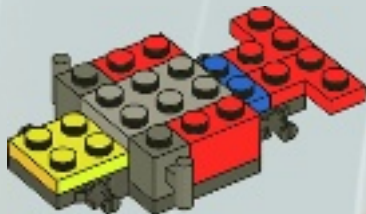

2x

5



1x



2x

6

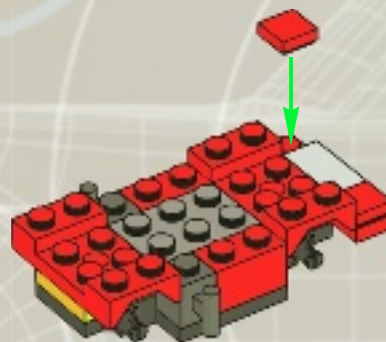



7

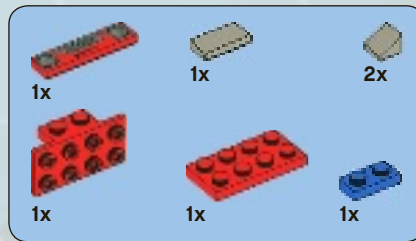
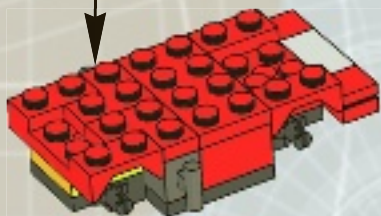

8

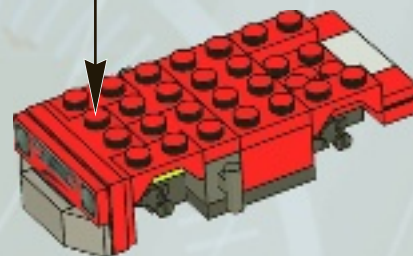
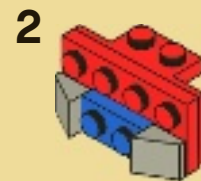
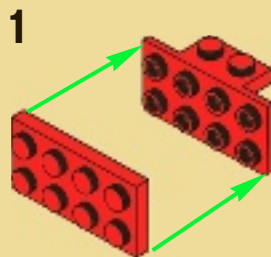

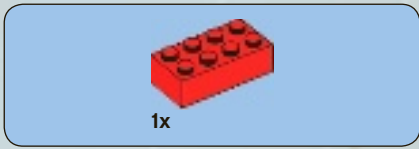

9

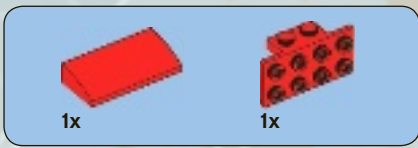
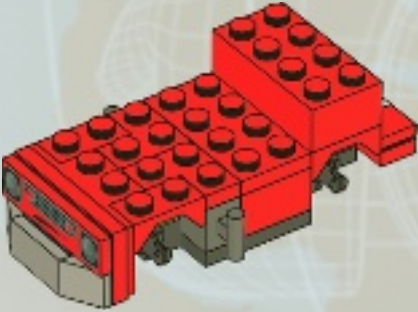

10

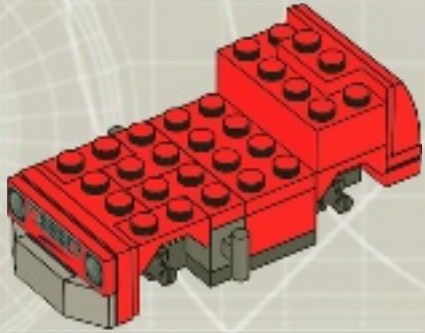
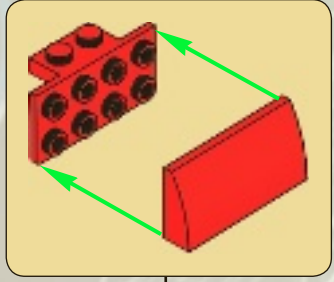



11

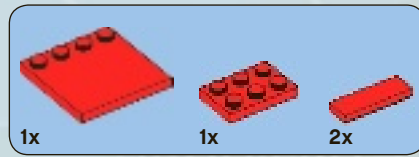
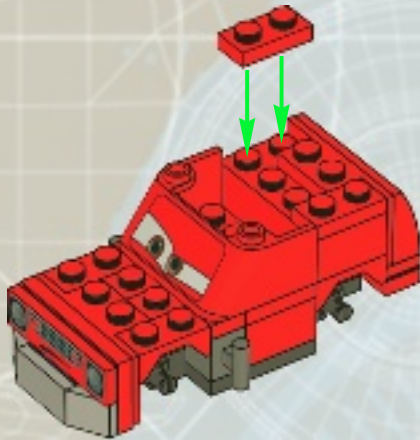

12

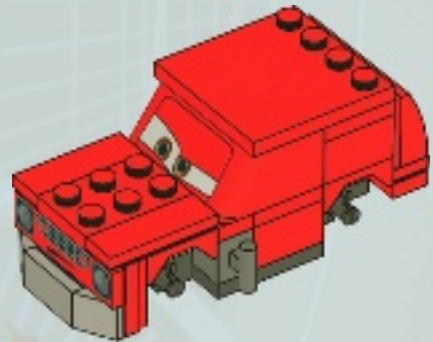

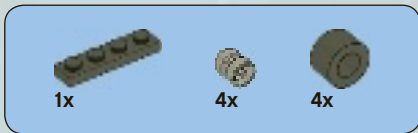

13

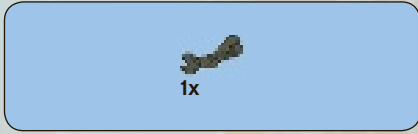
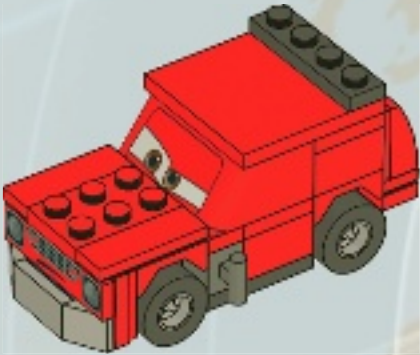

14



15





2



1

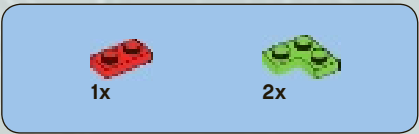

3

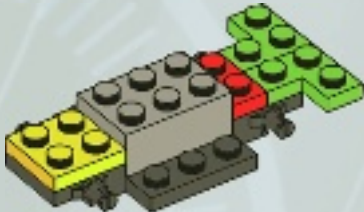
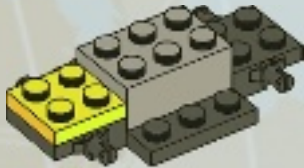



4

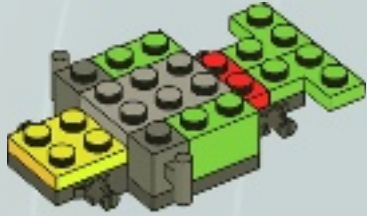

5

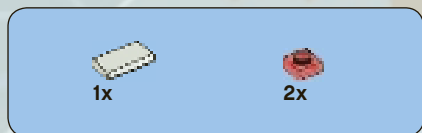

6

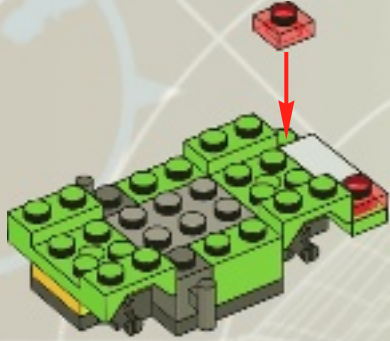

7

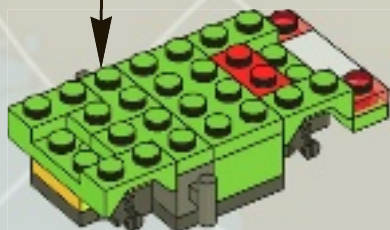



8

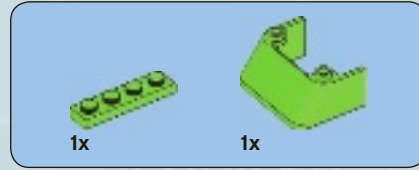
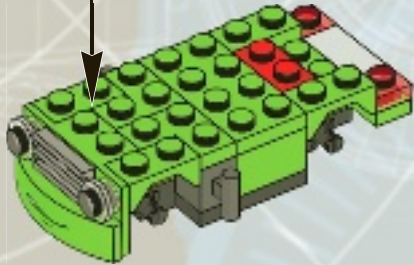
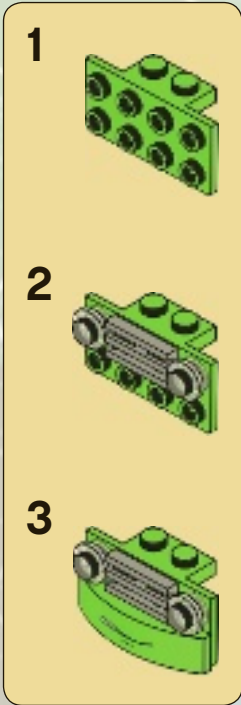

9

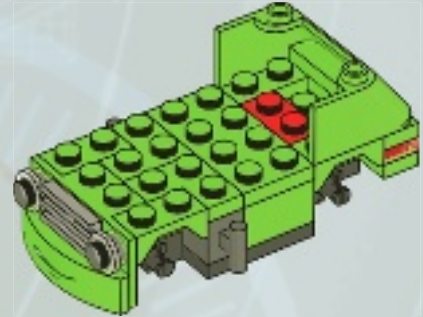
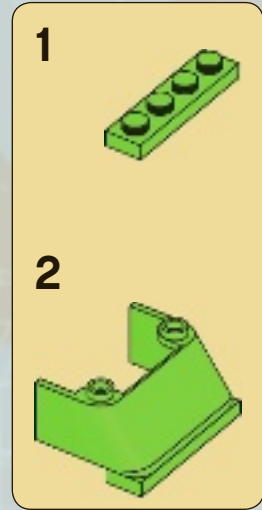



1x



1x

10

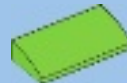
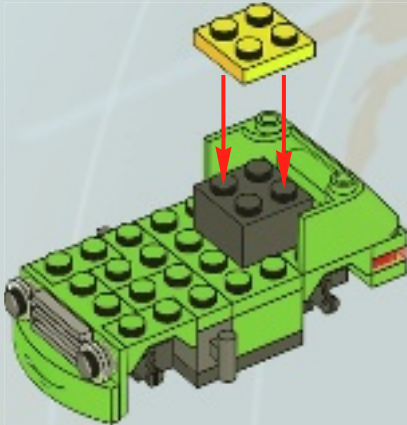

2x

12

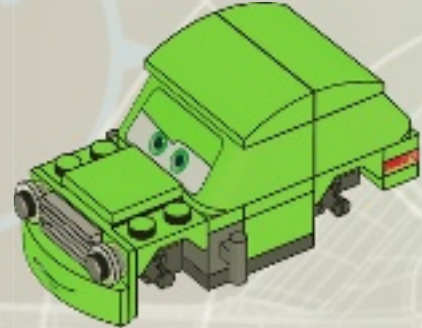

1x



1x

11

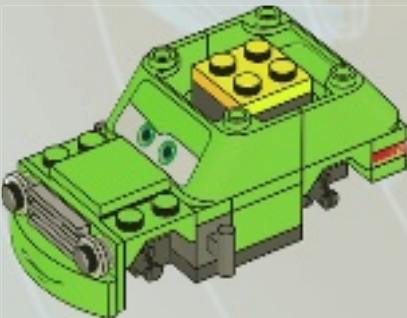

4x



4x

13

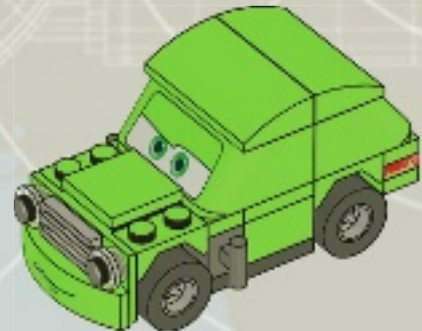



1x

14



1x



1x



1x



1x

15

1

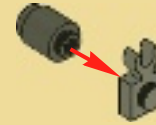

2



3

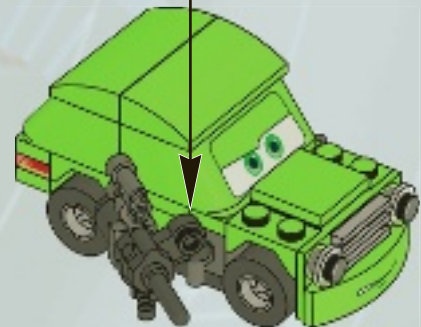

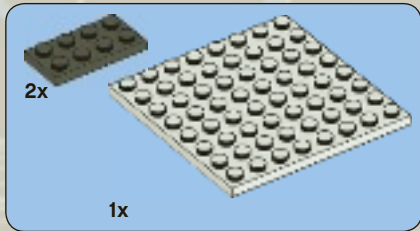

1

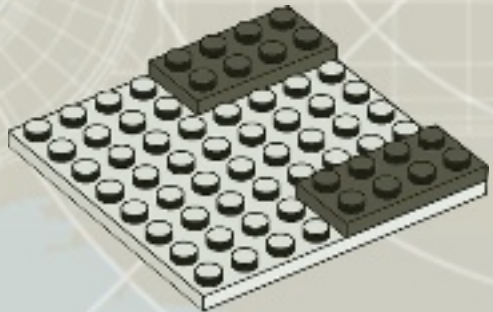



1x



2x

2

target
acquired

waypoint 2

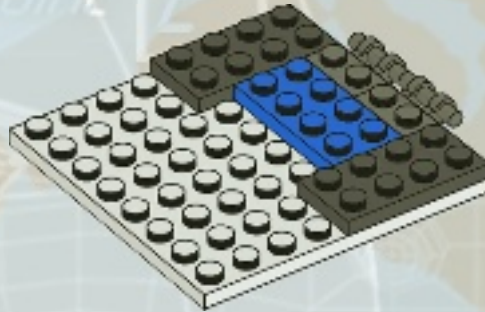

2x

3



laypoint 1

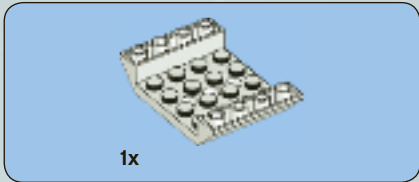

4

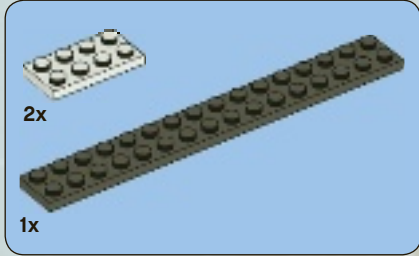
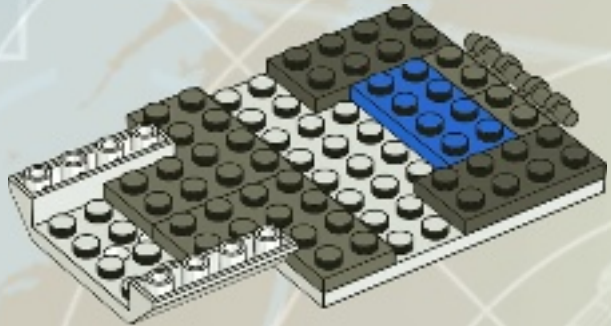

5

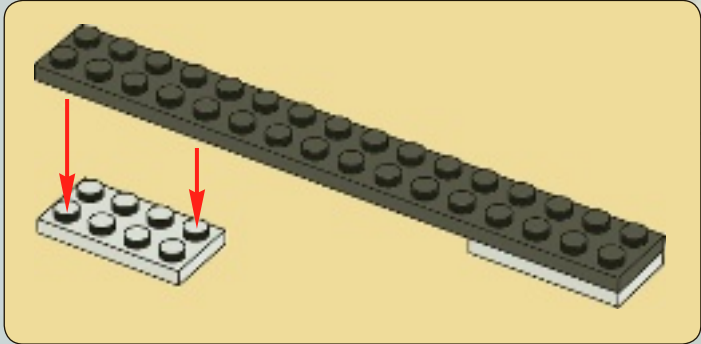

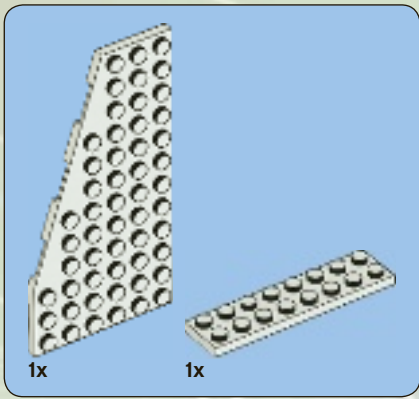

6

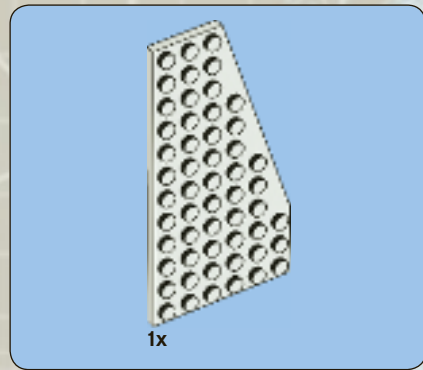
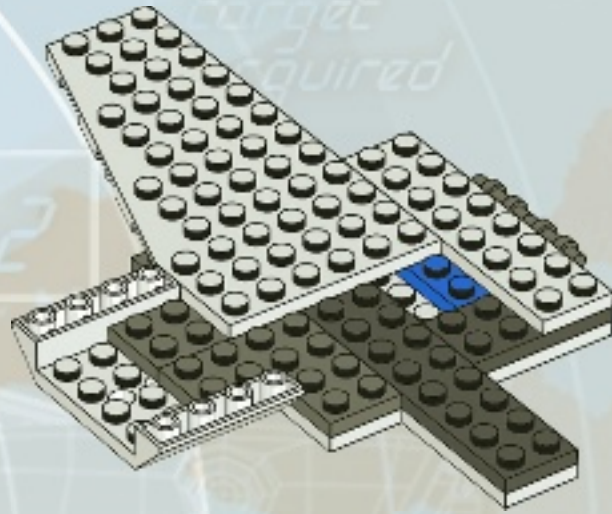

7

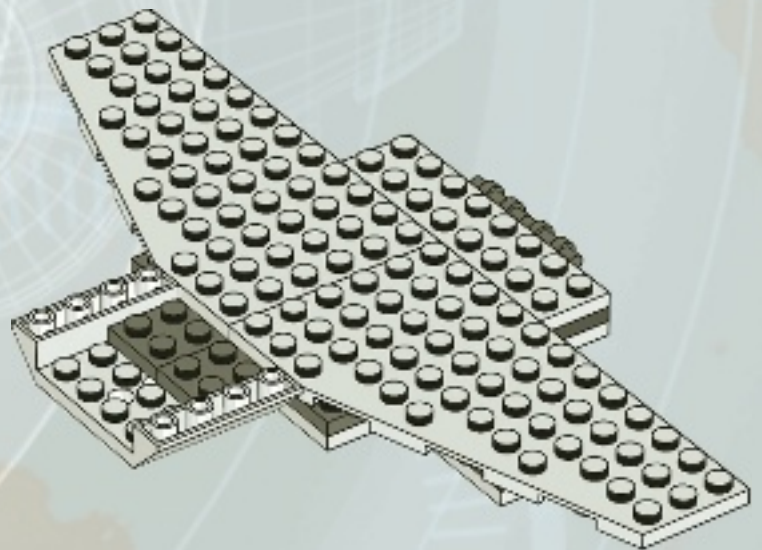

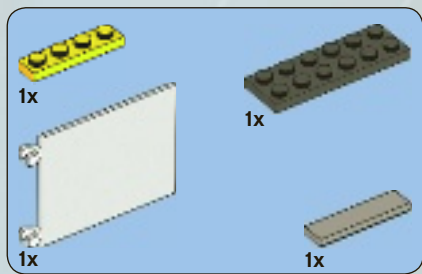

8

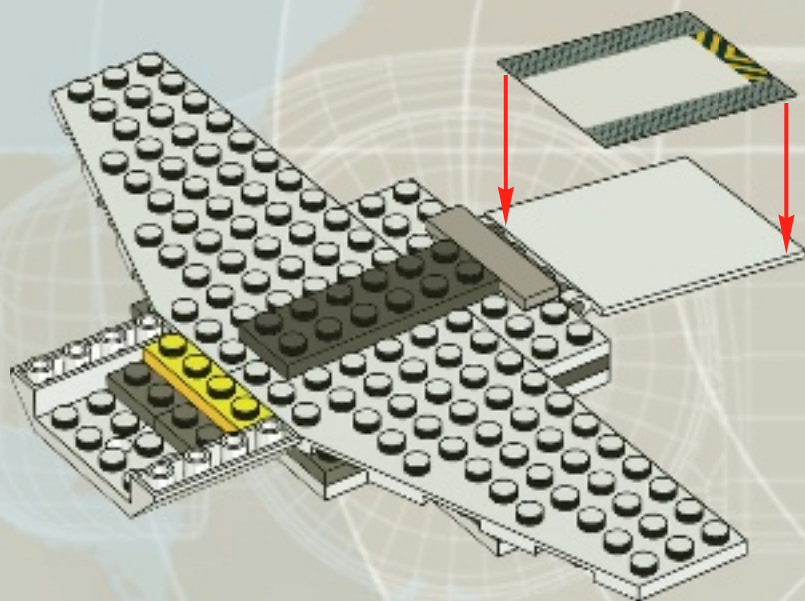

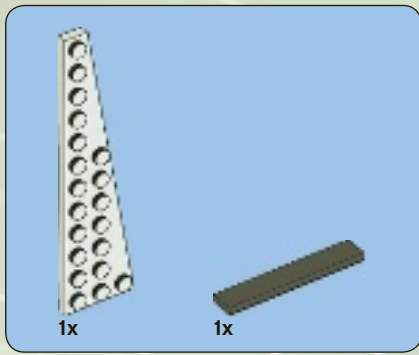

9

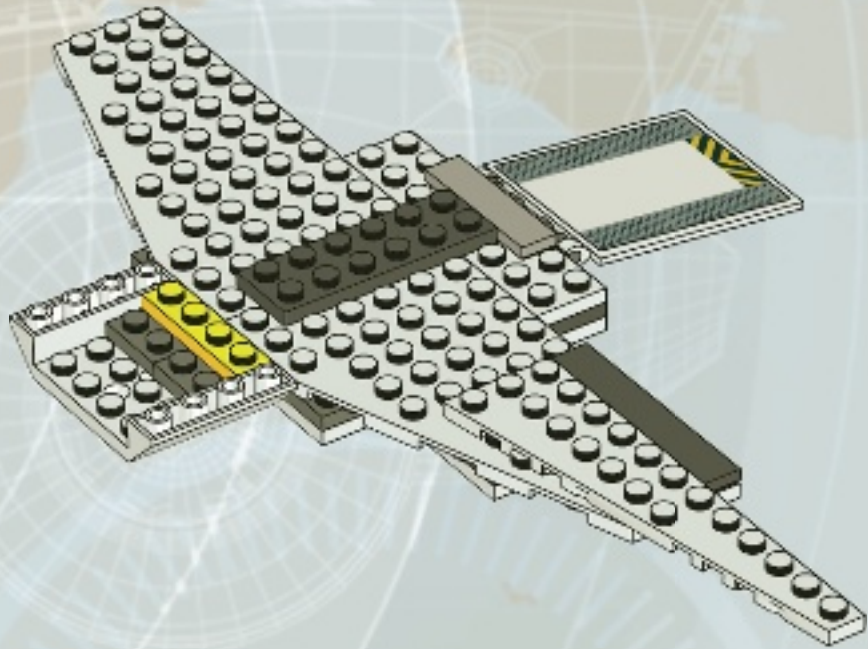

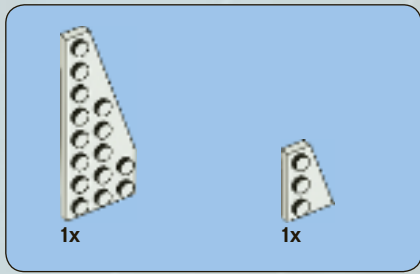

10

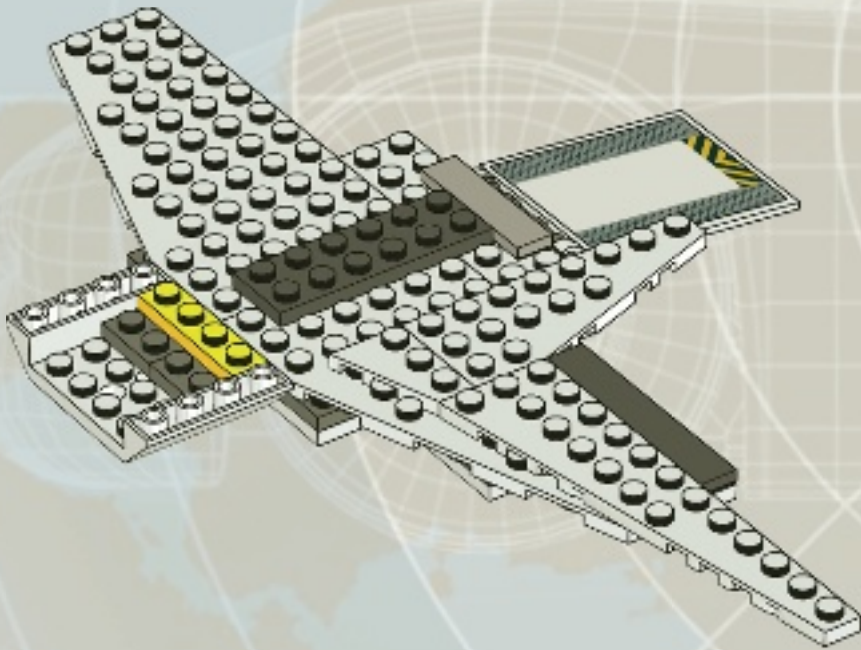

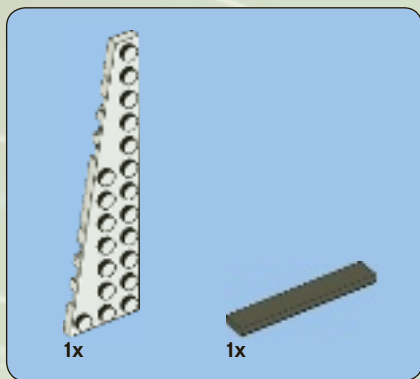

11

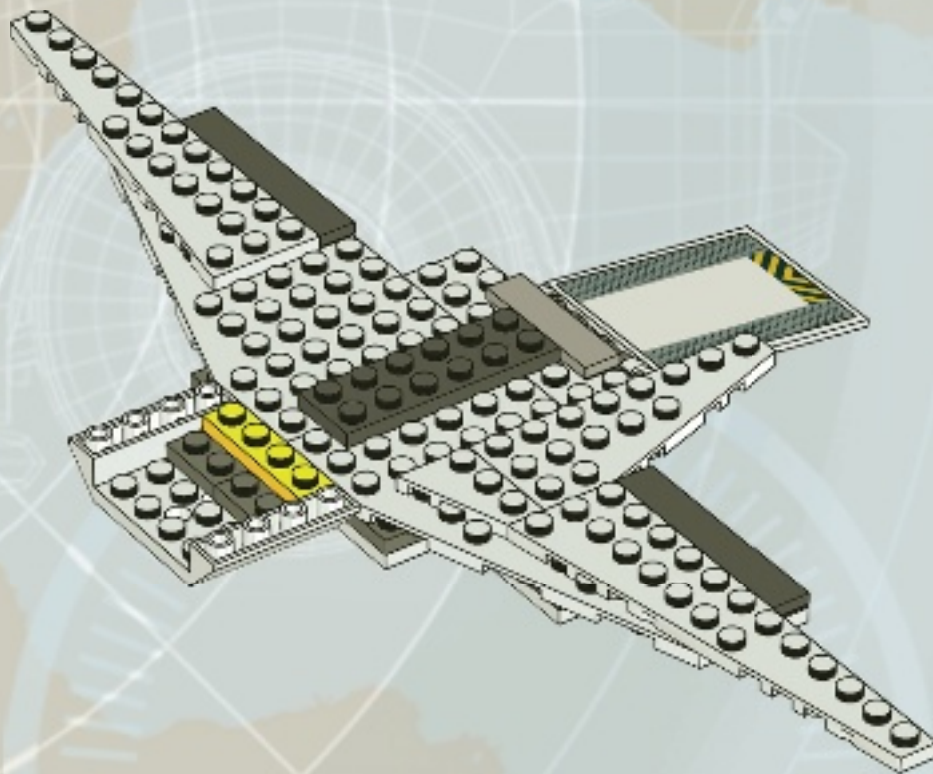

aypoint 1

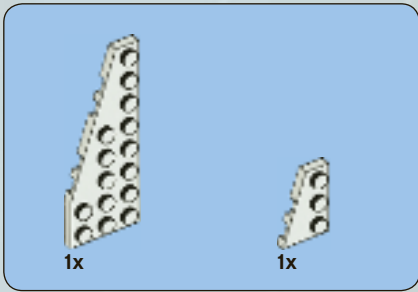

12

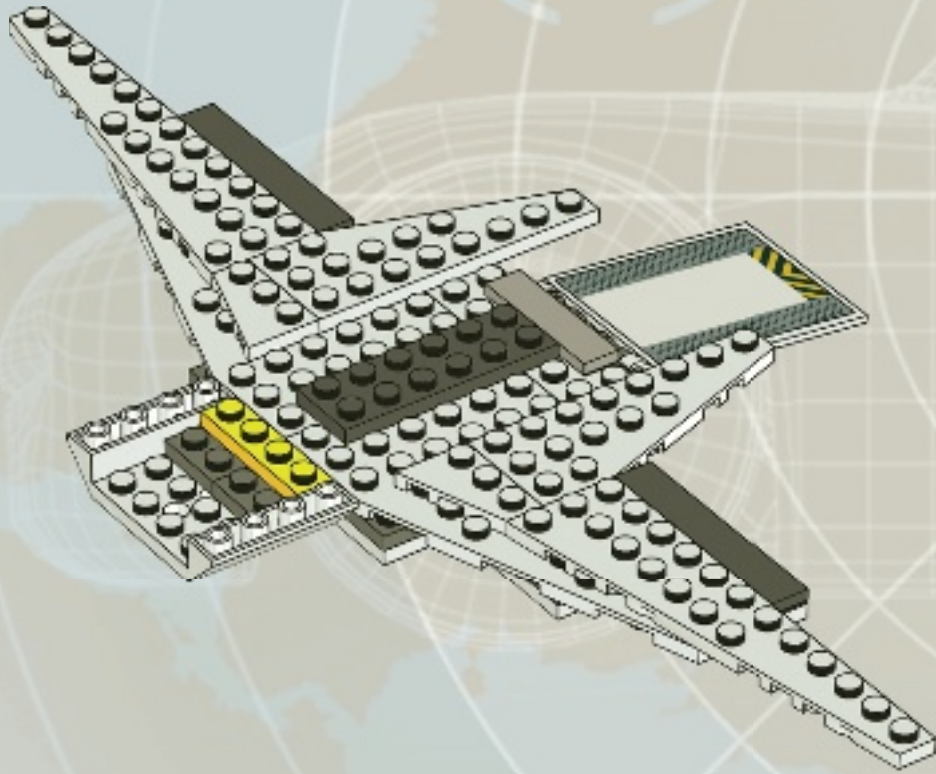

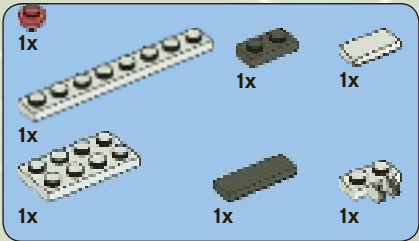
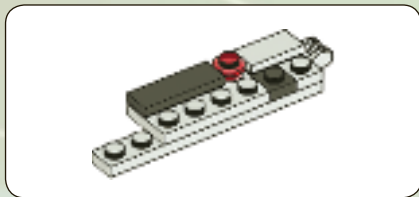

13

1



2



3



4

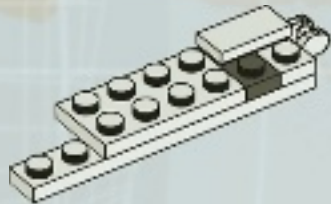

5

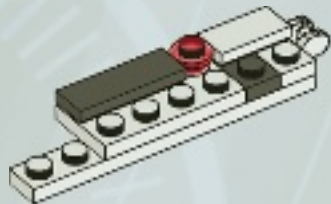

waypoint

1

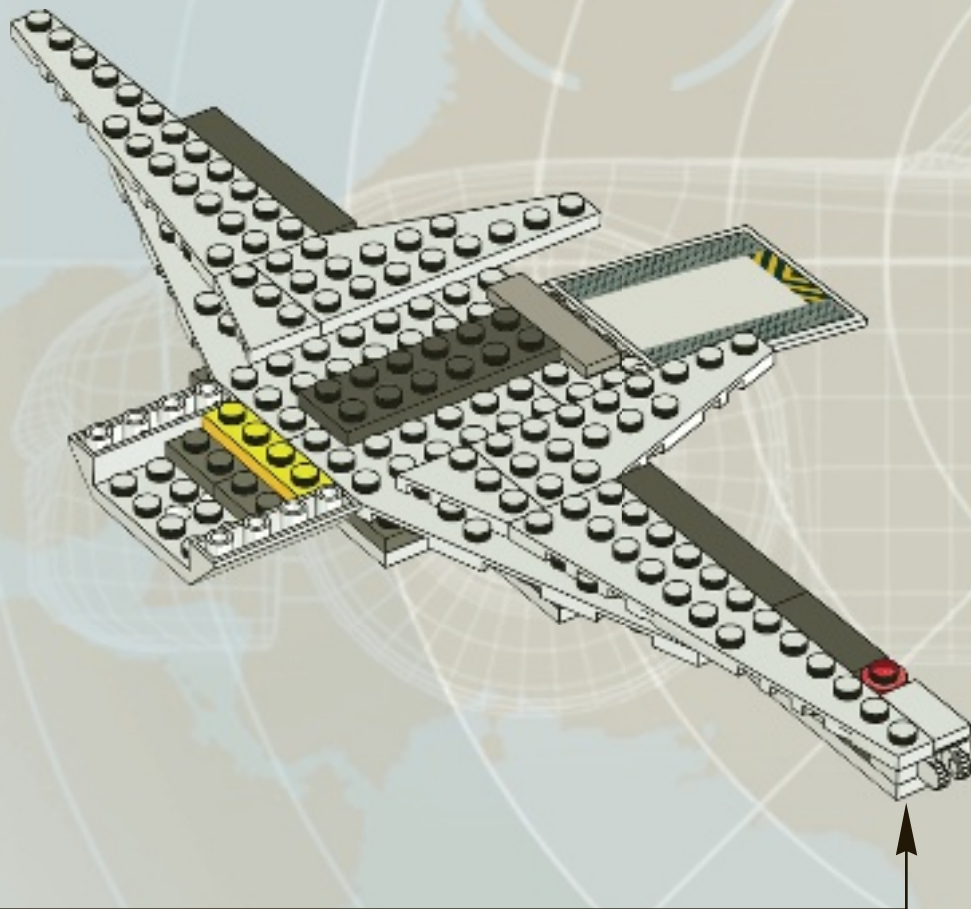



14

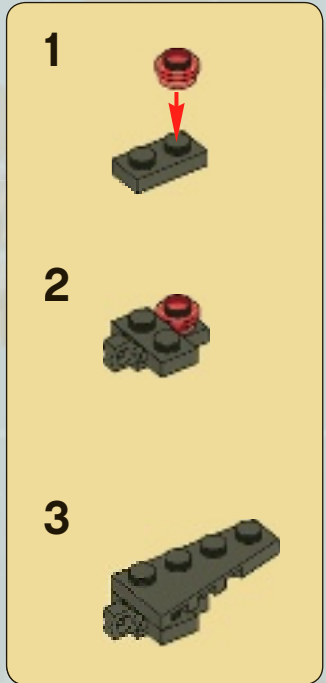
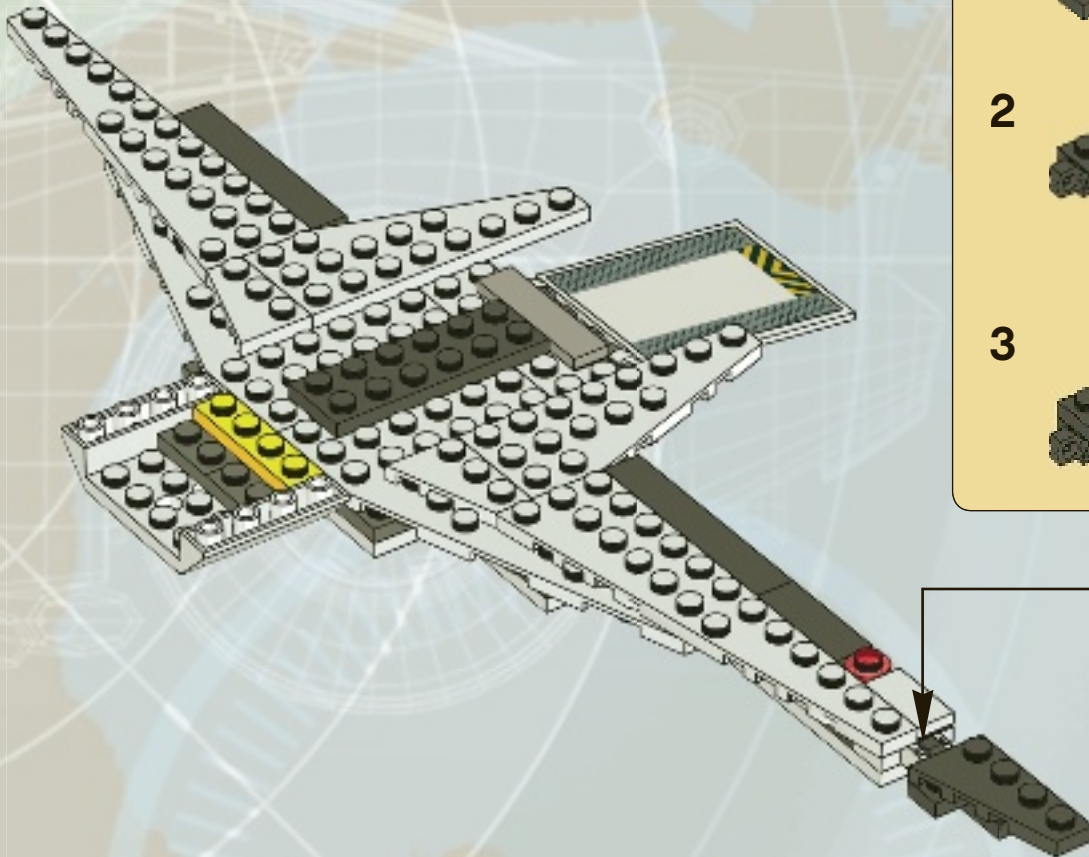

aypoint

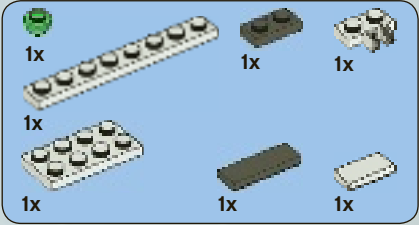
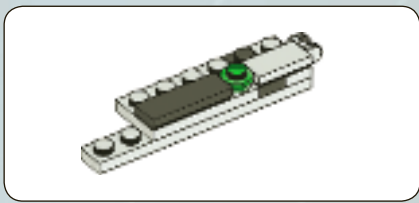

15

1



2

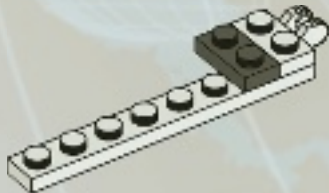

3



4

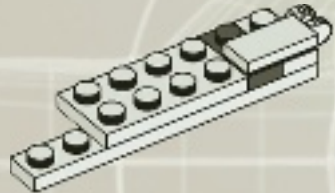

5

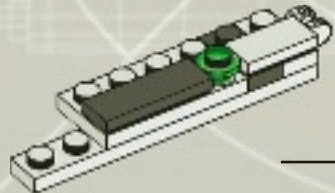

target
acquired

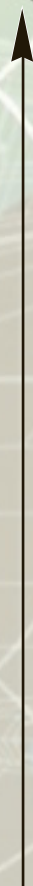
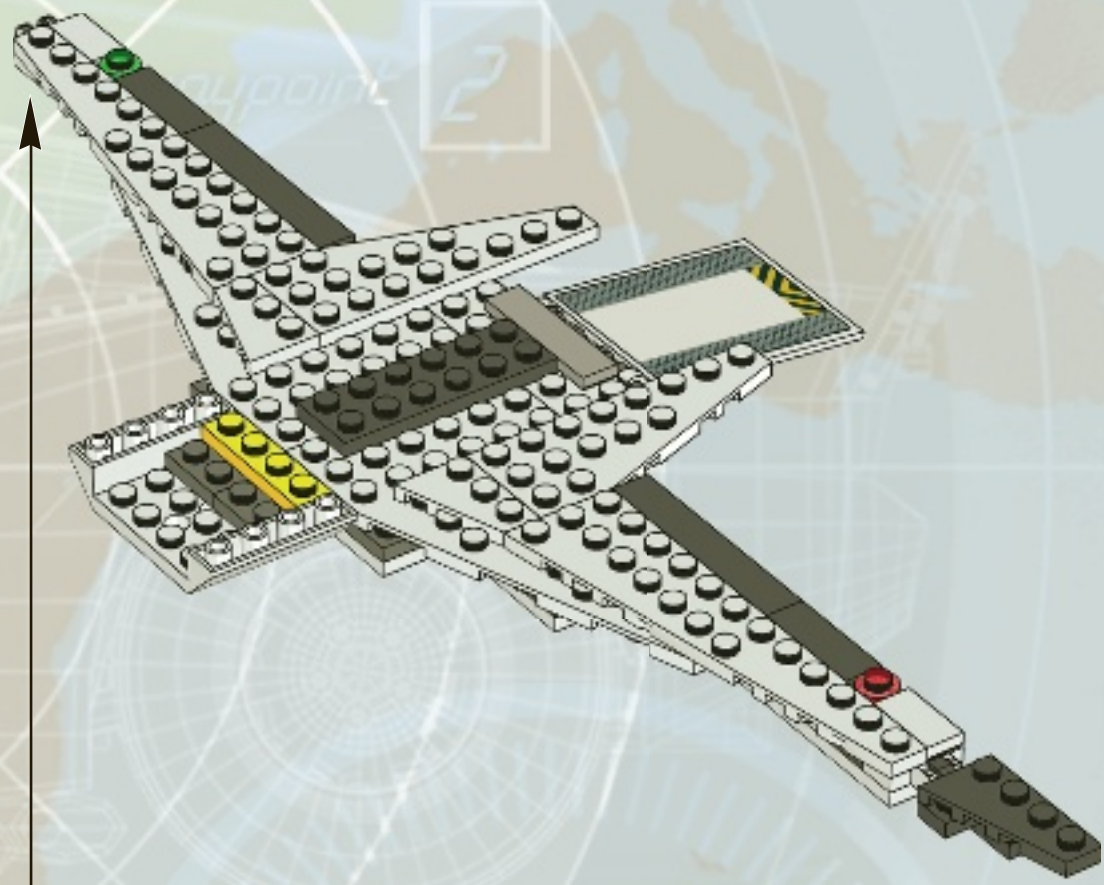



16

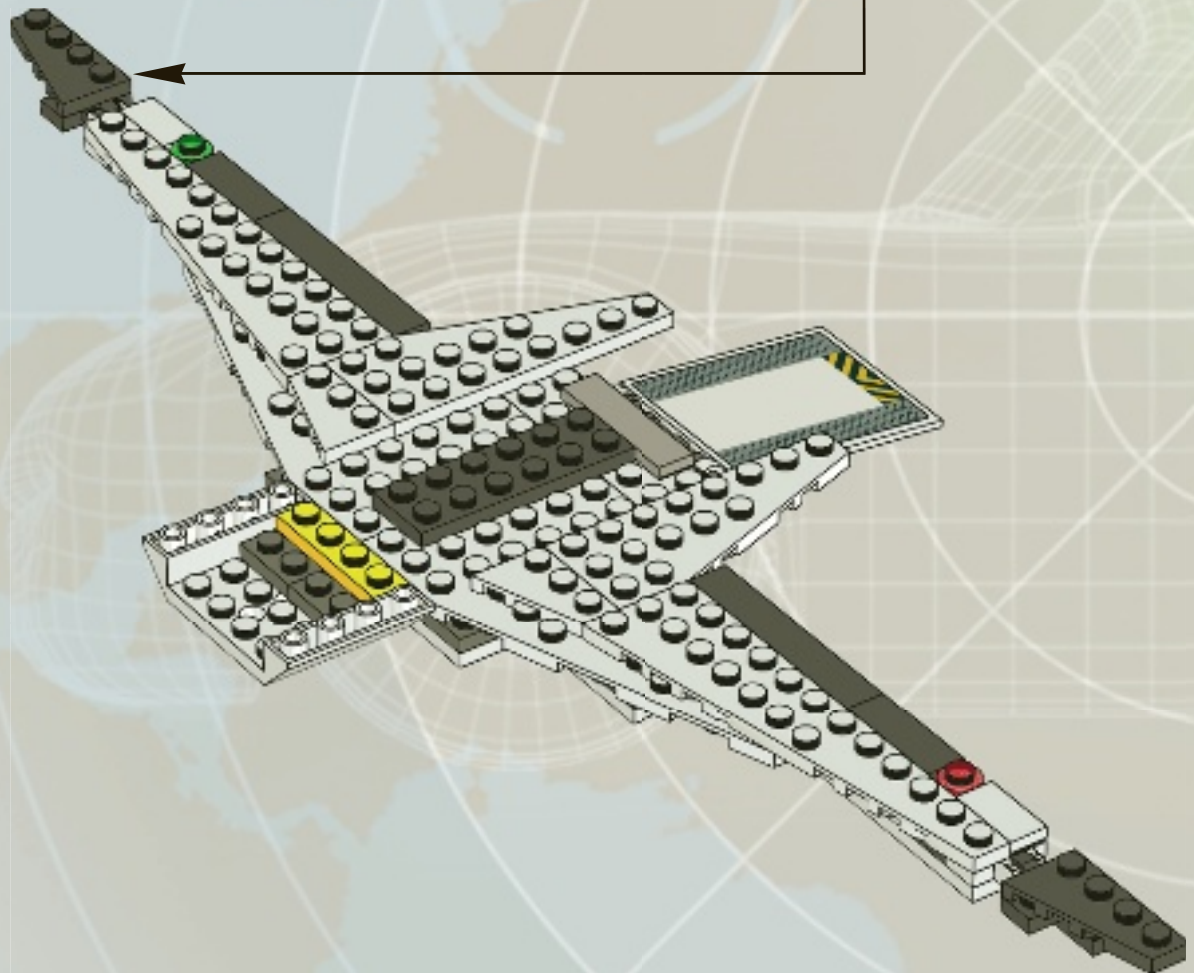



2x

17

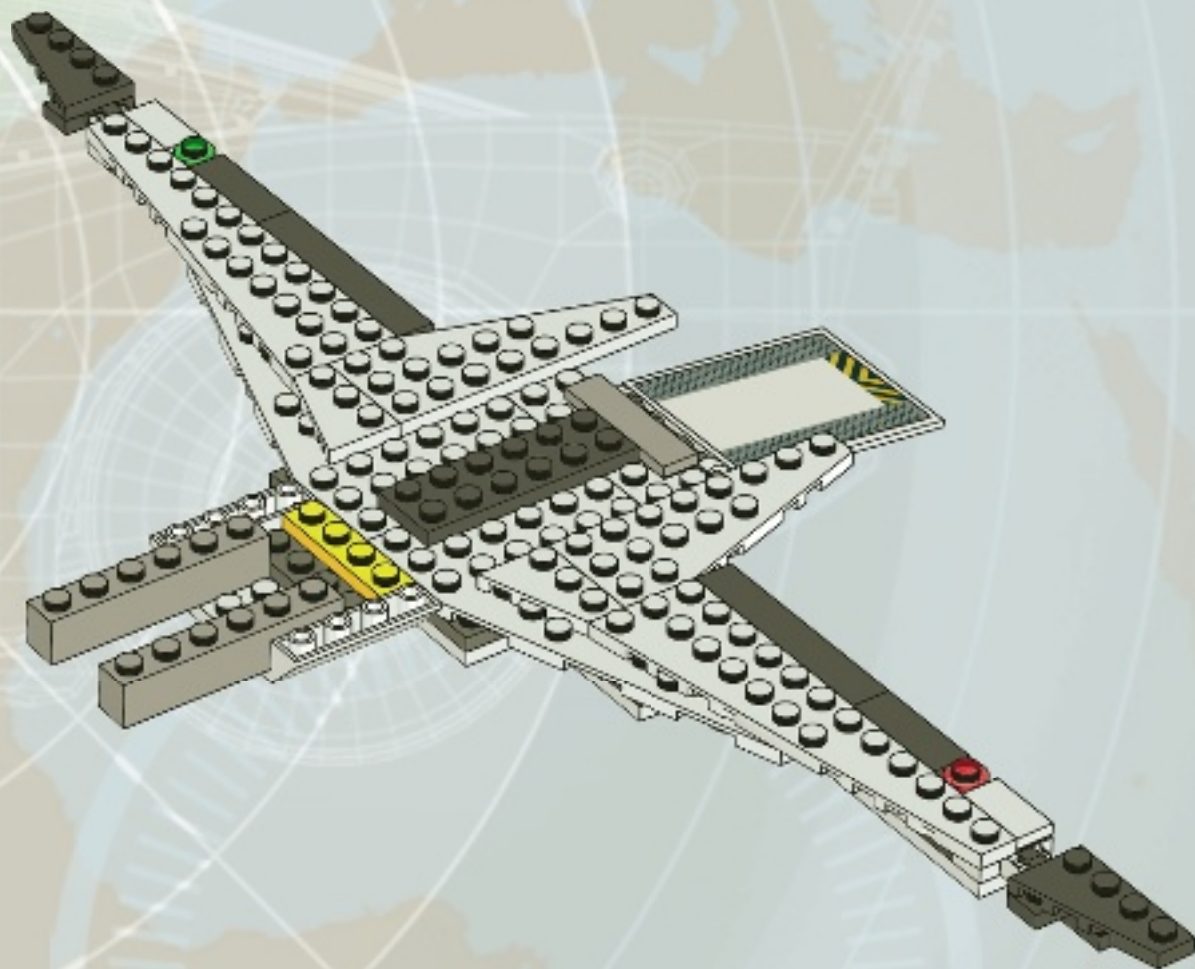

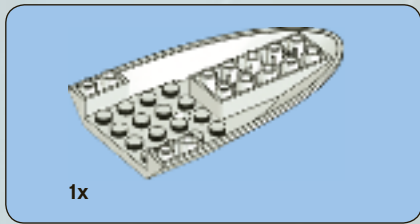

18

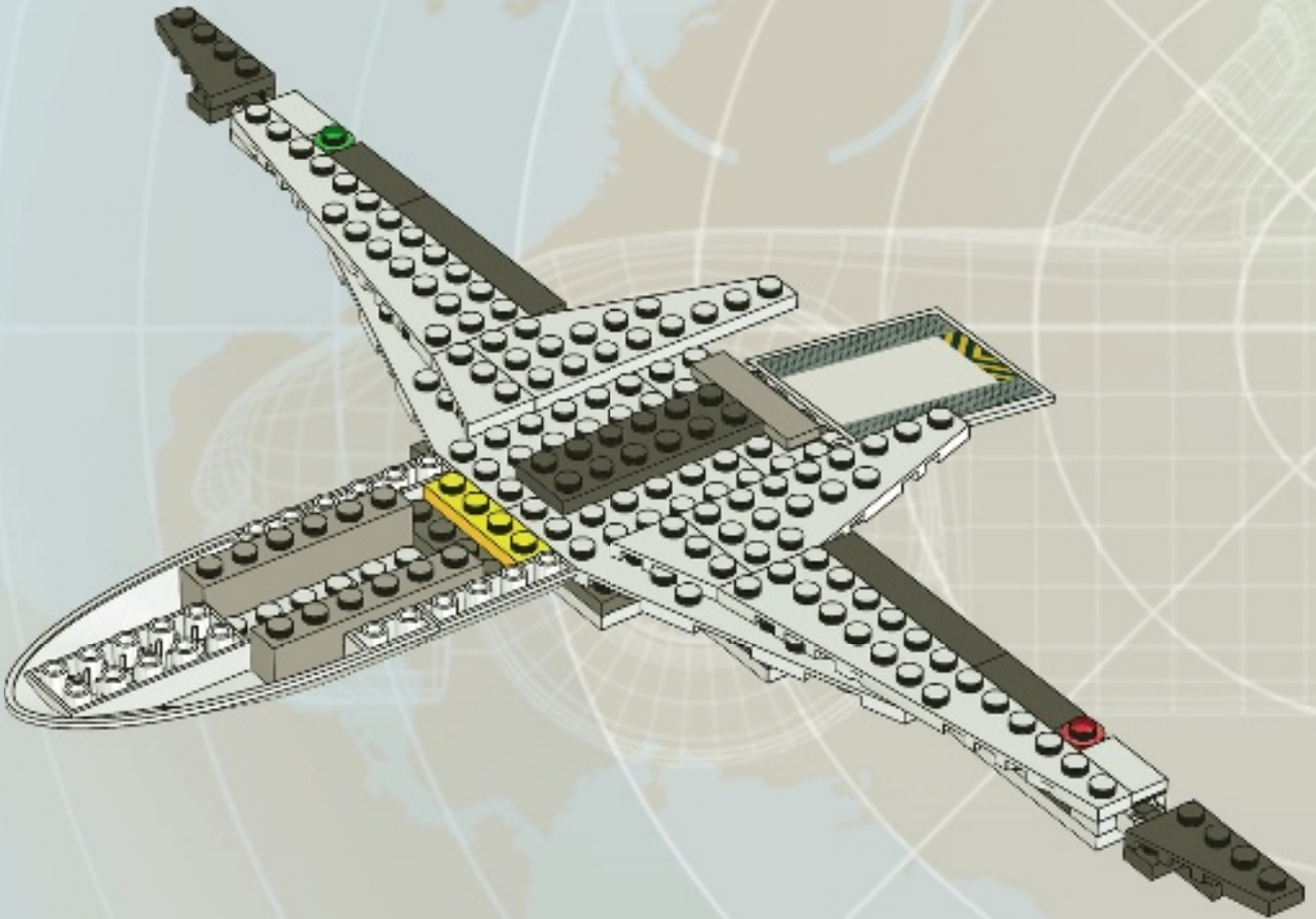



19

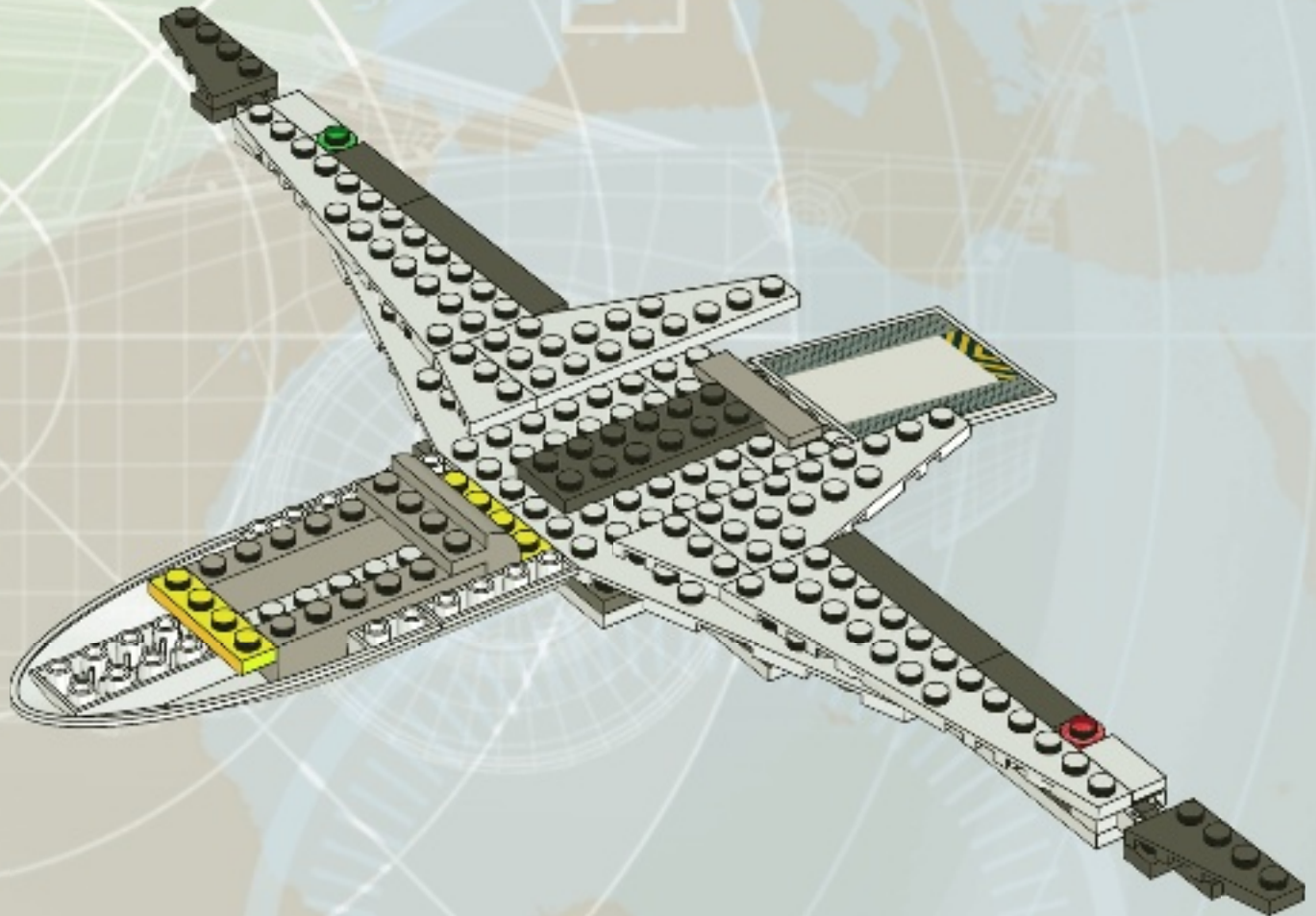

laypoint 1

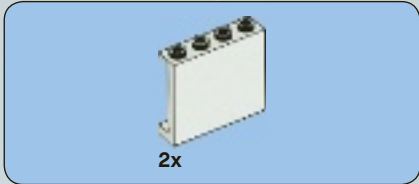

20

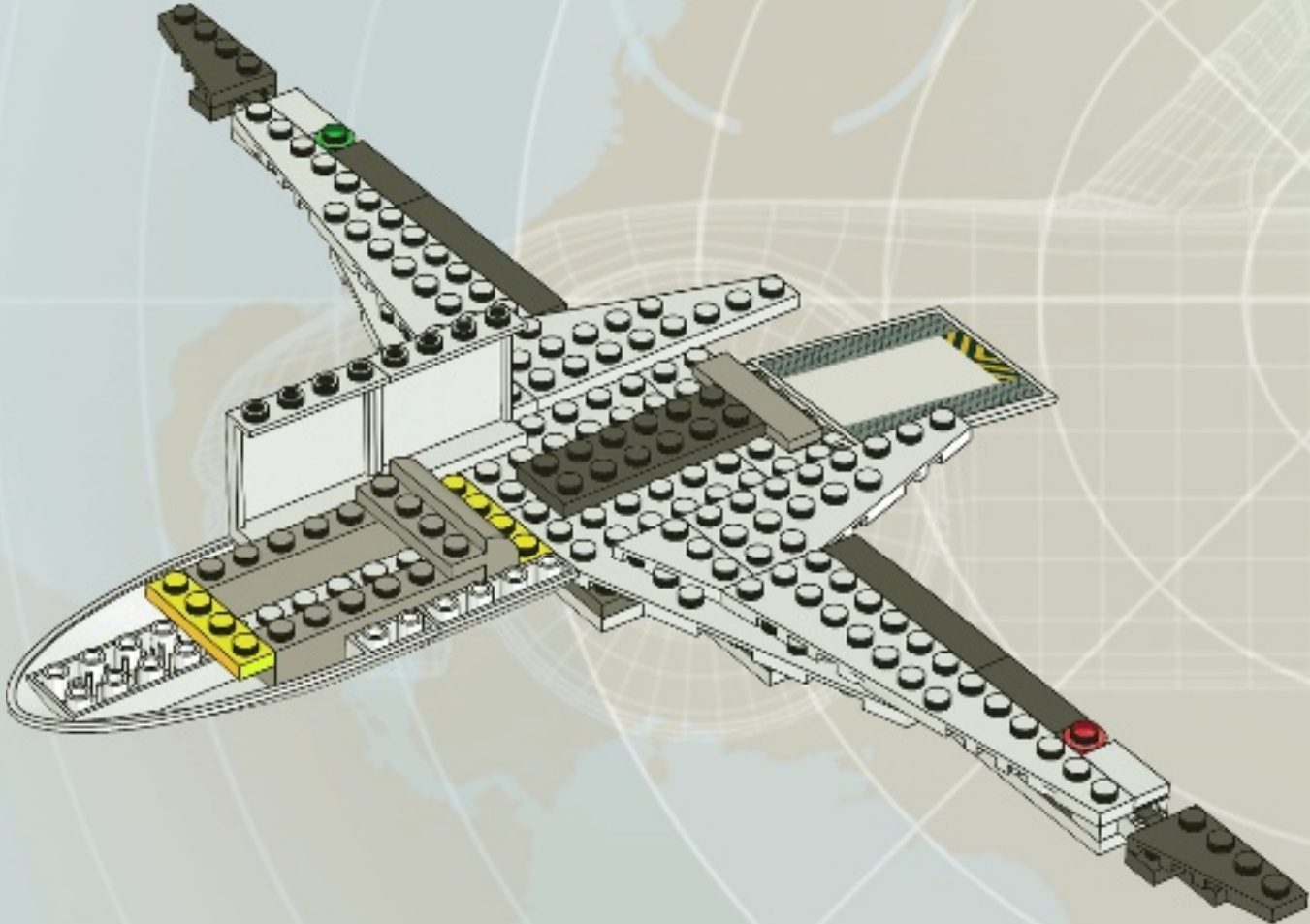

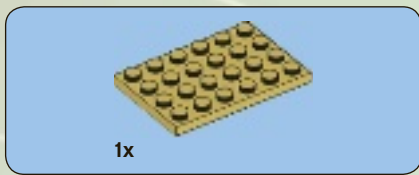

21

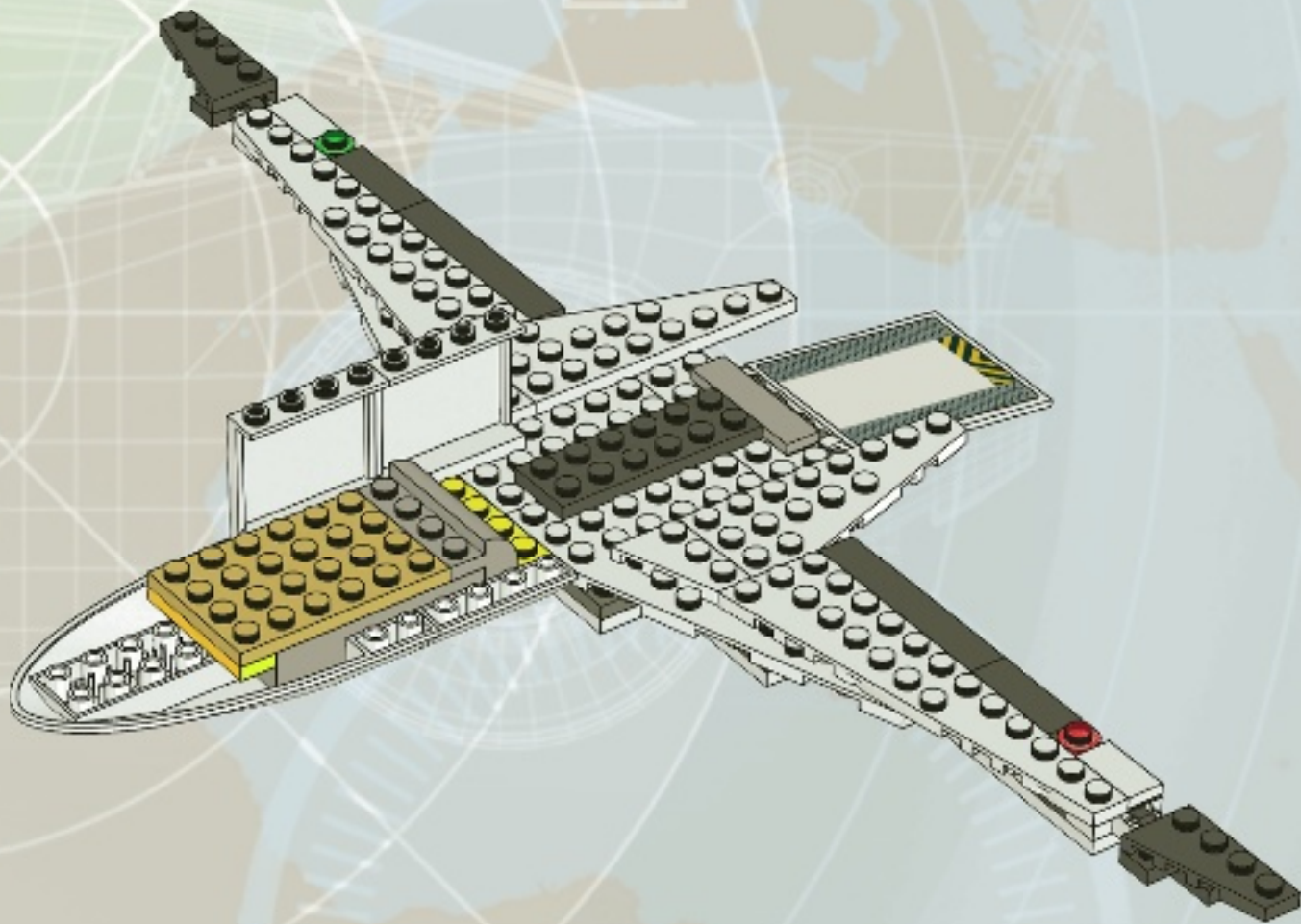

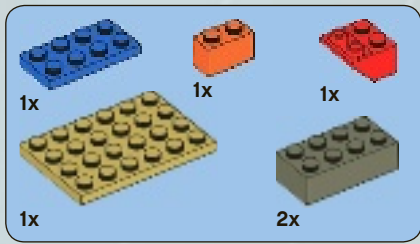

22

1

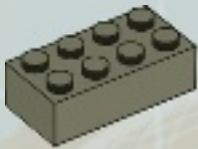

2

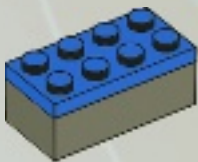

3



4

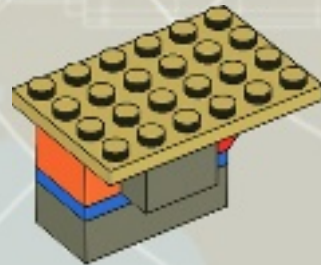

target
acquired

waypoint 2

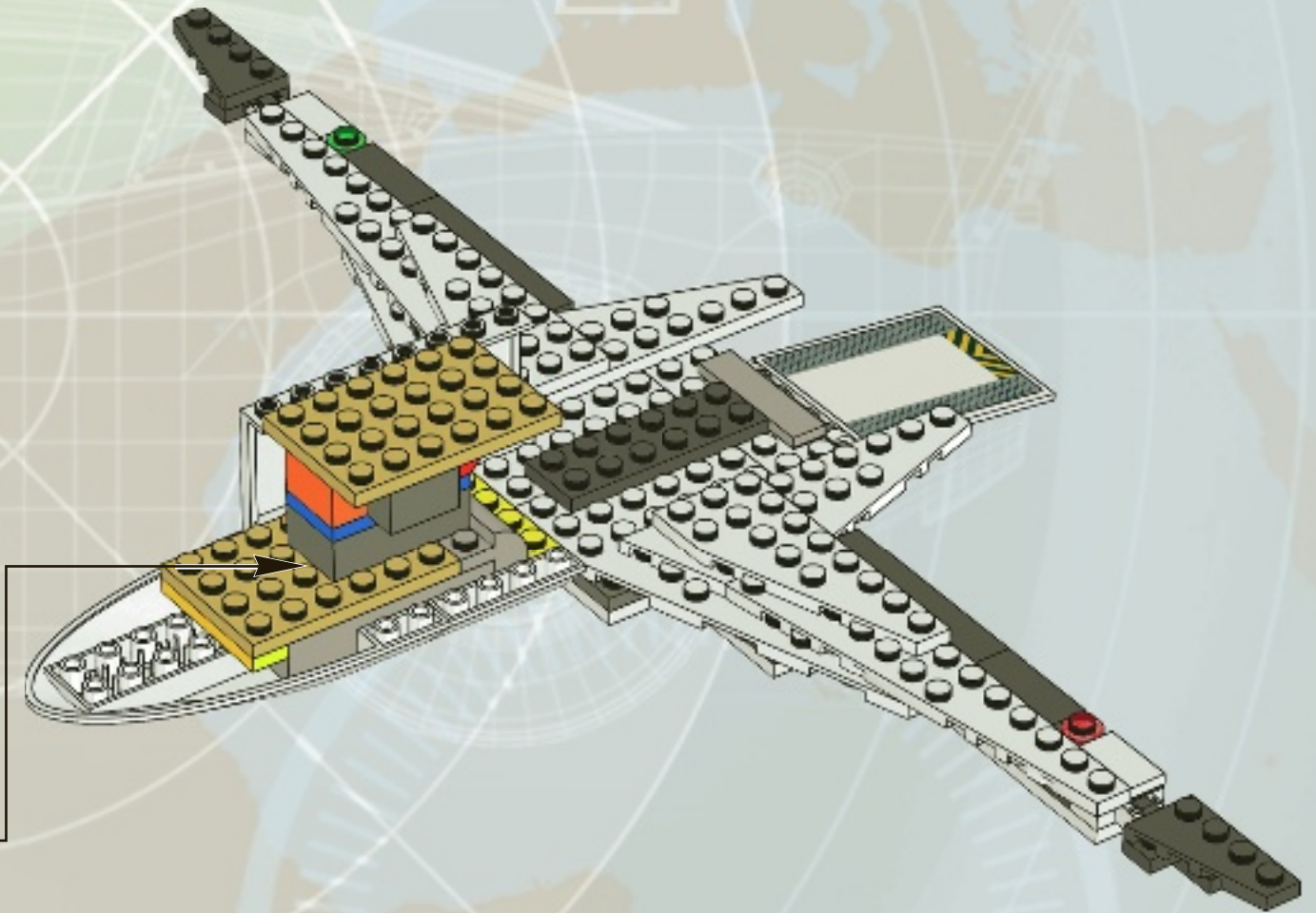



4

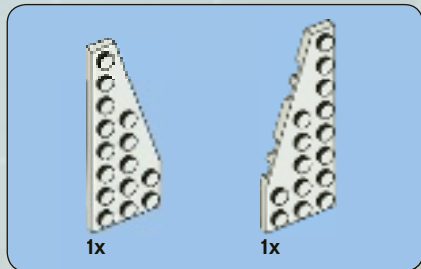

23

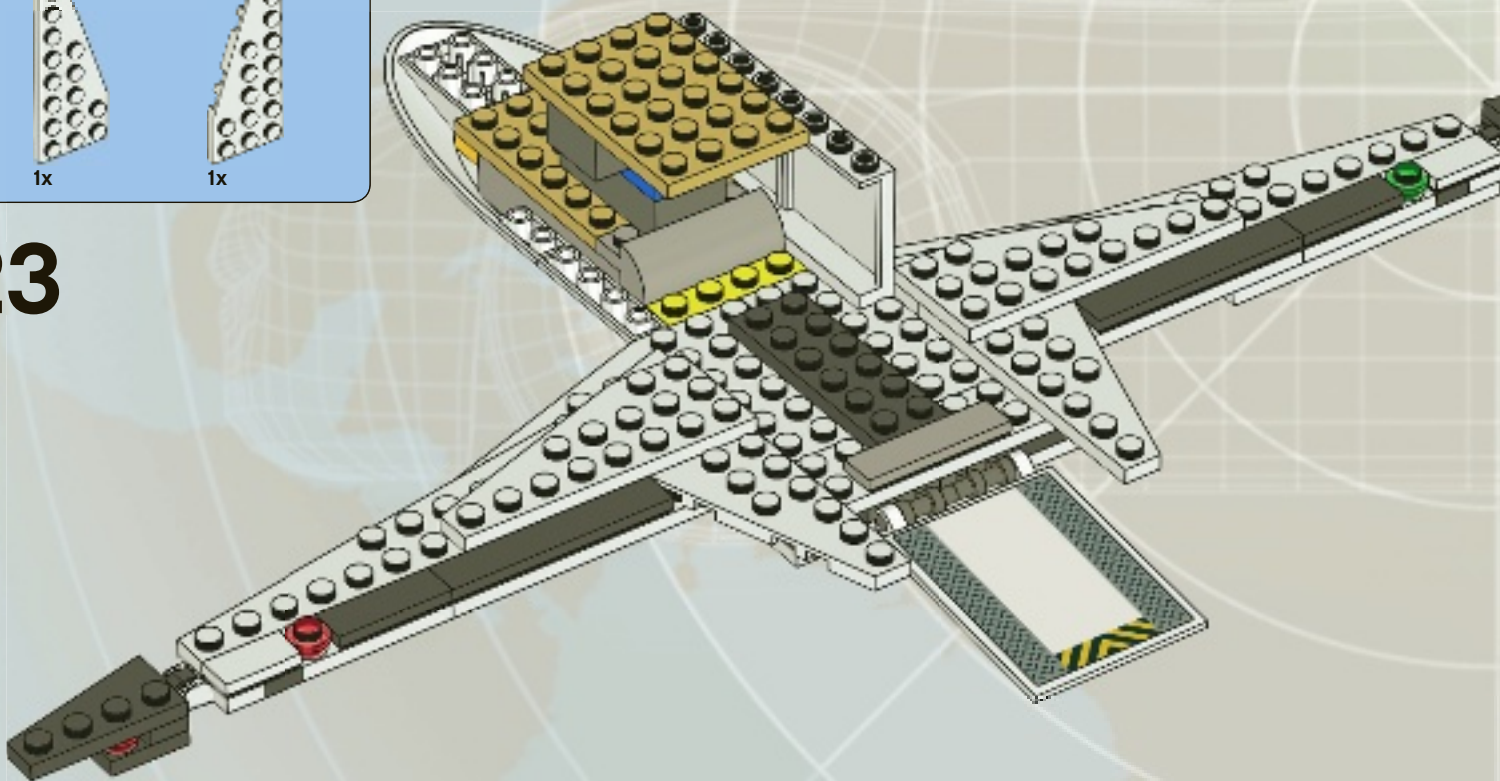

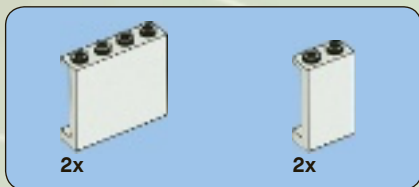

24

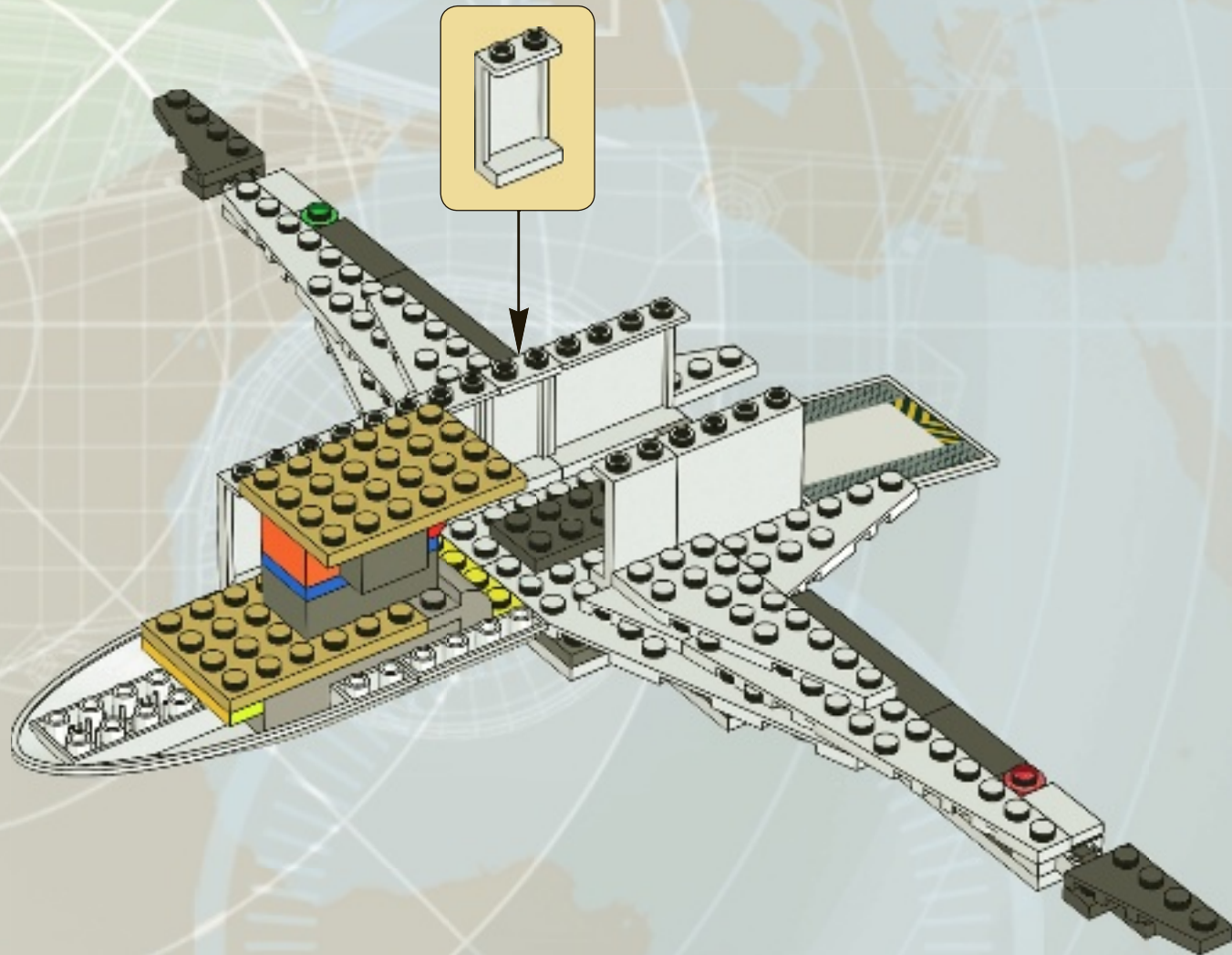



25

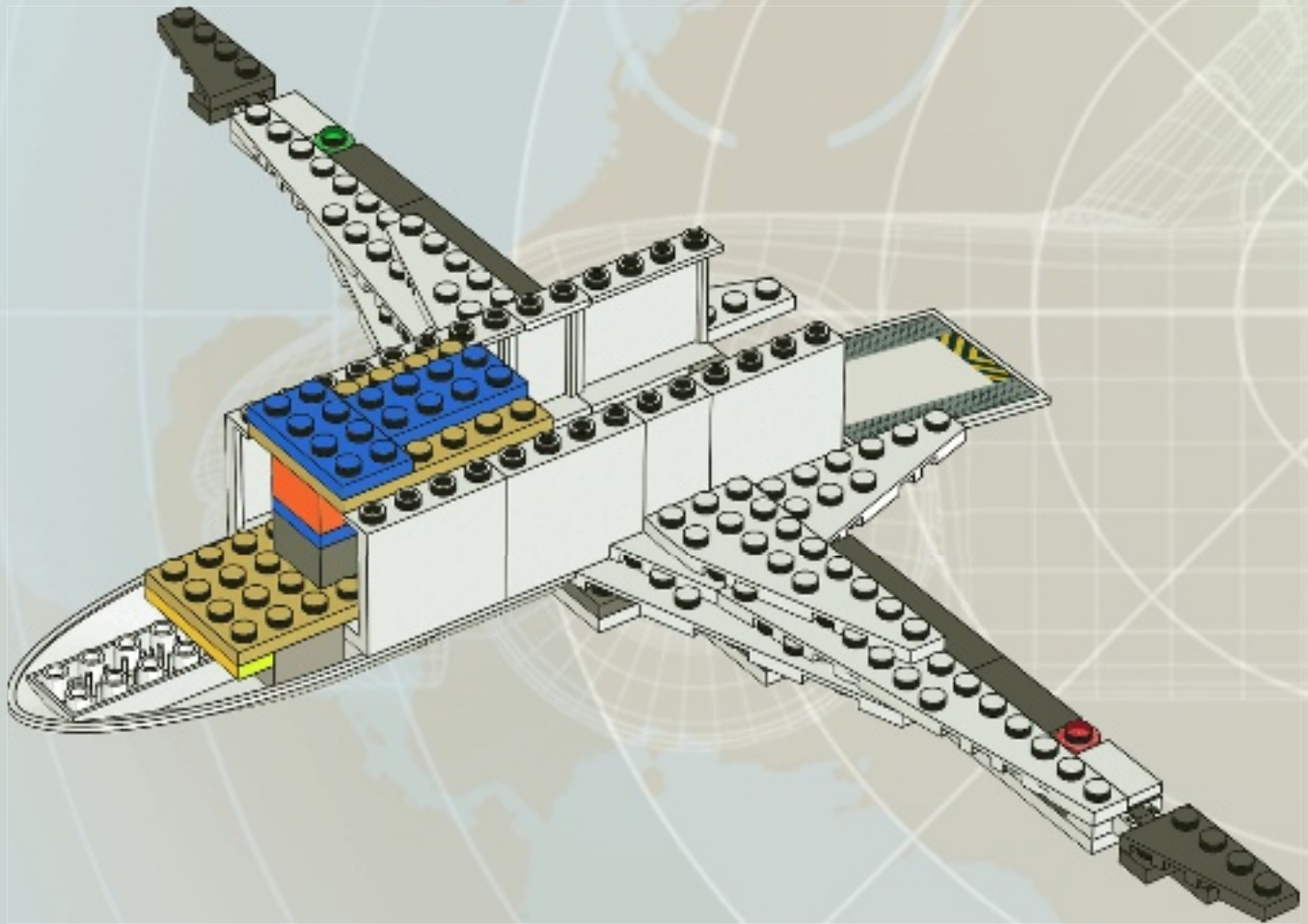

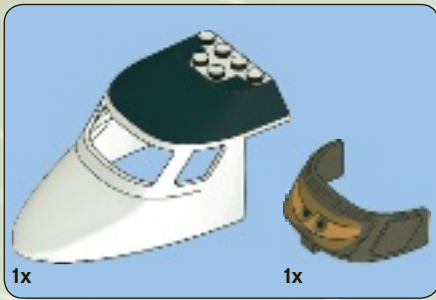

26

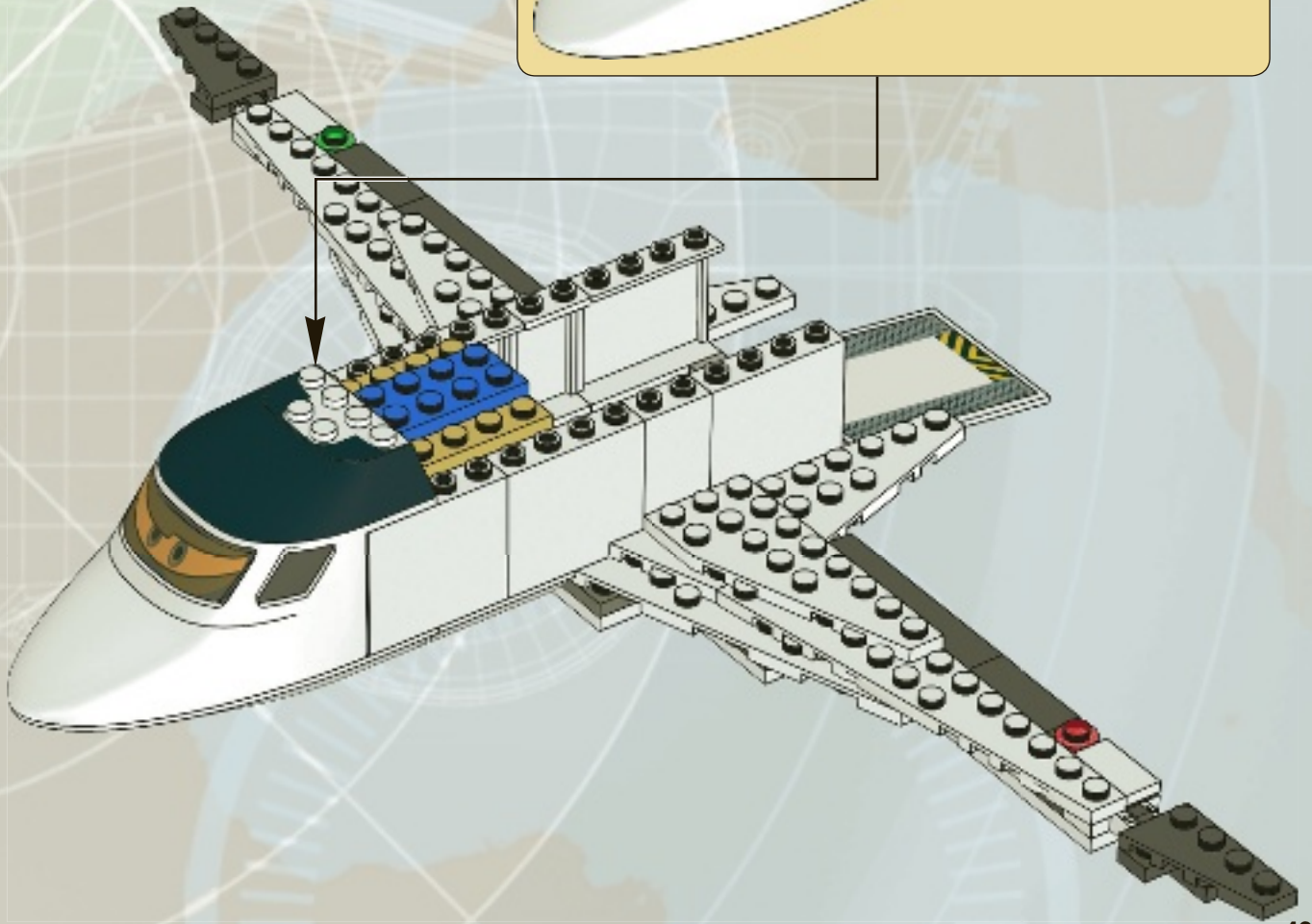
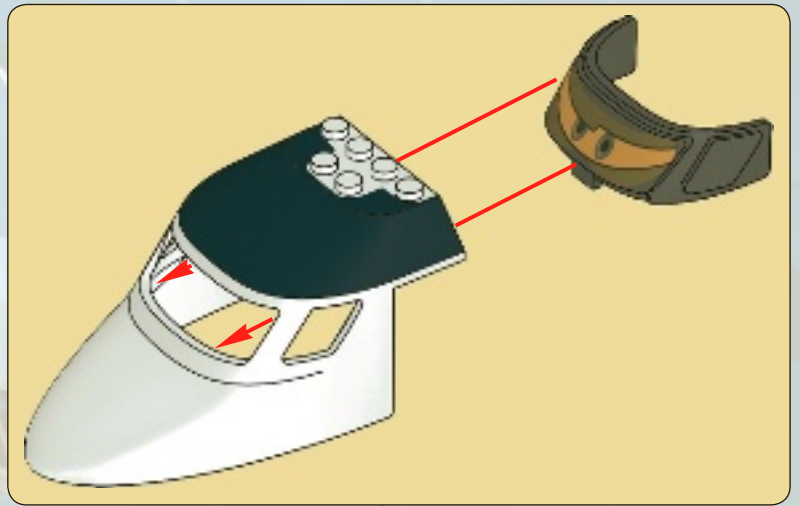

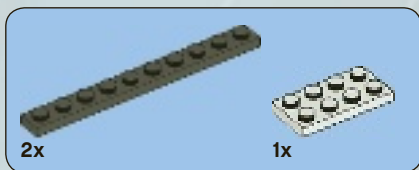

27

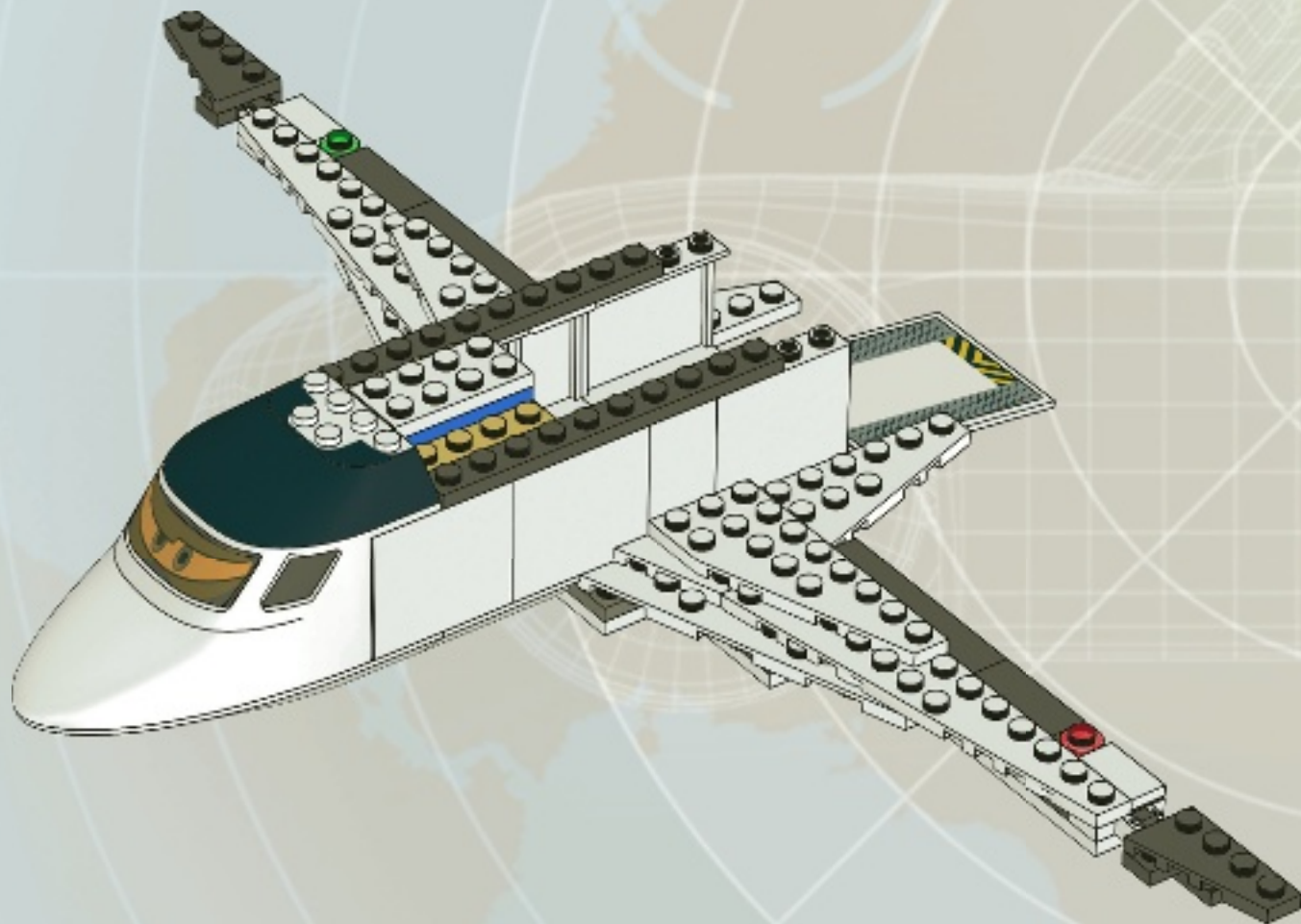

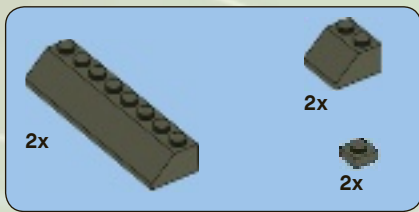

28

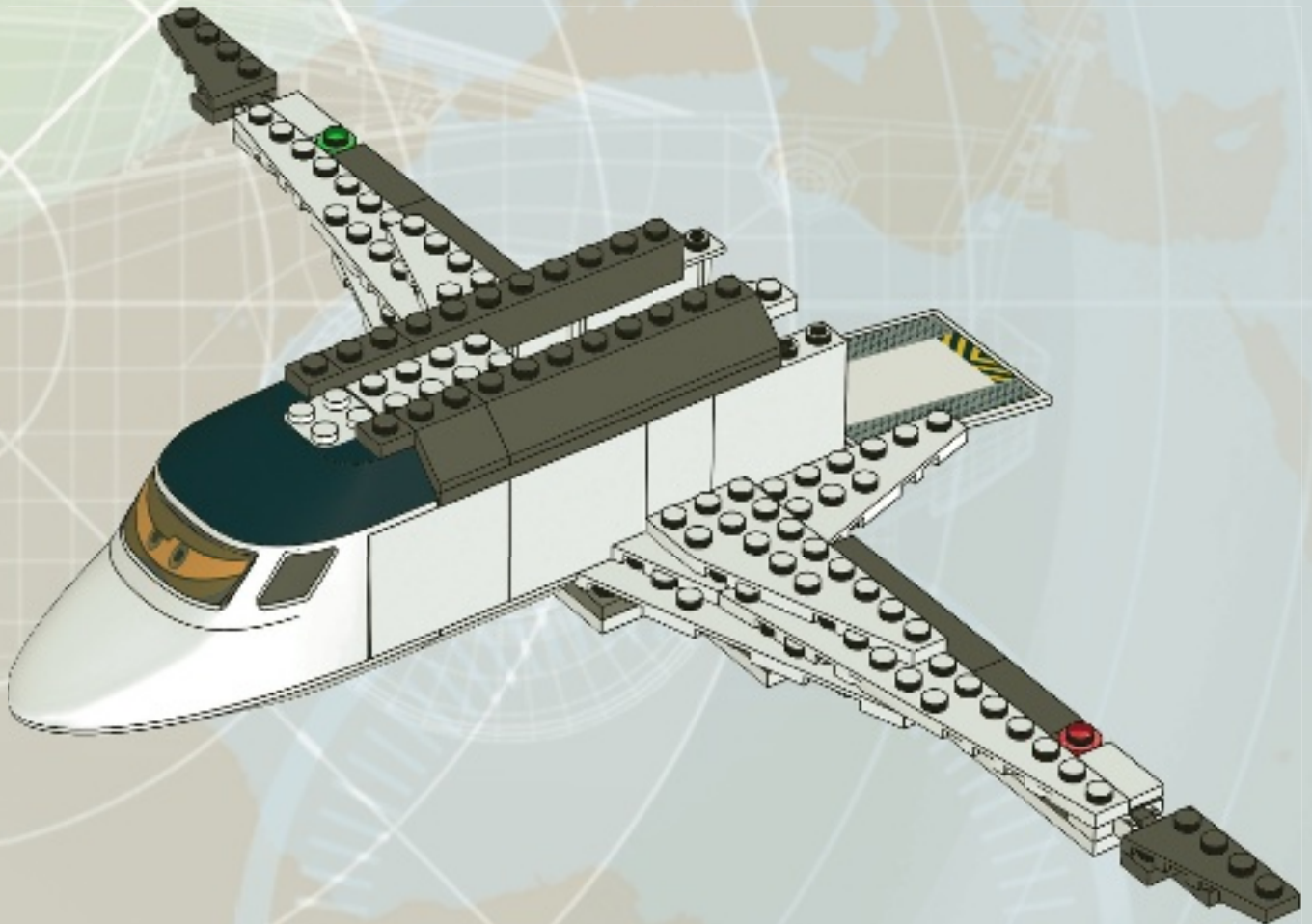

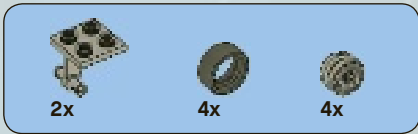

29

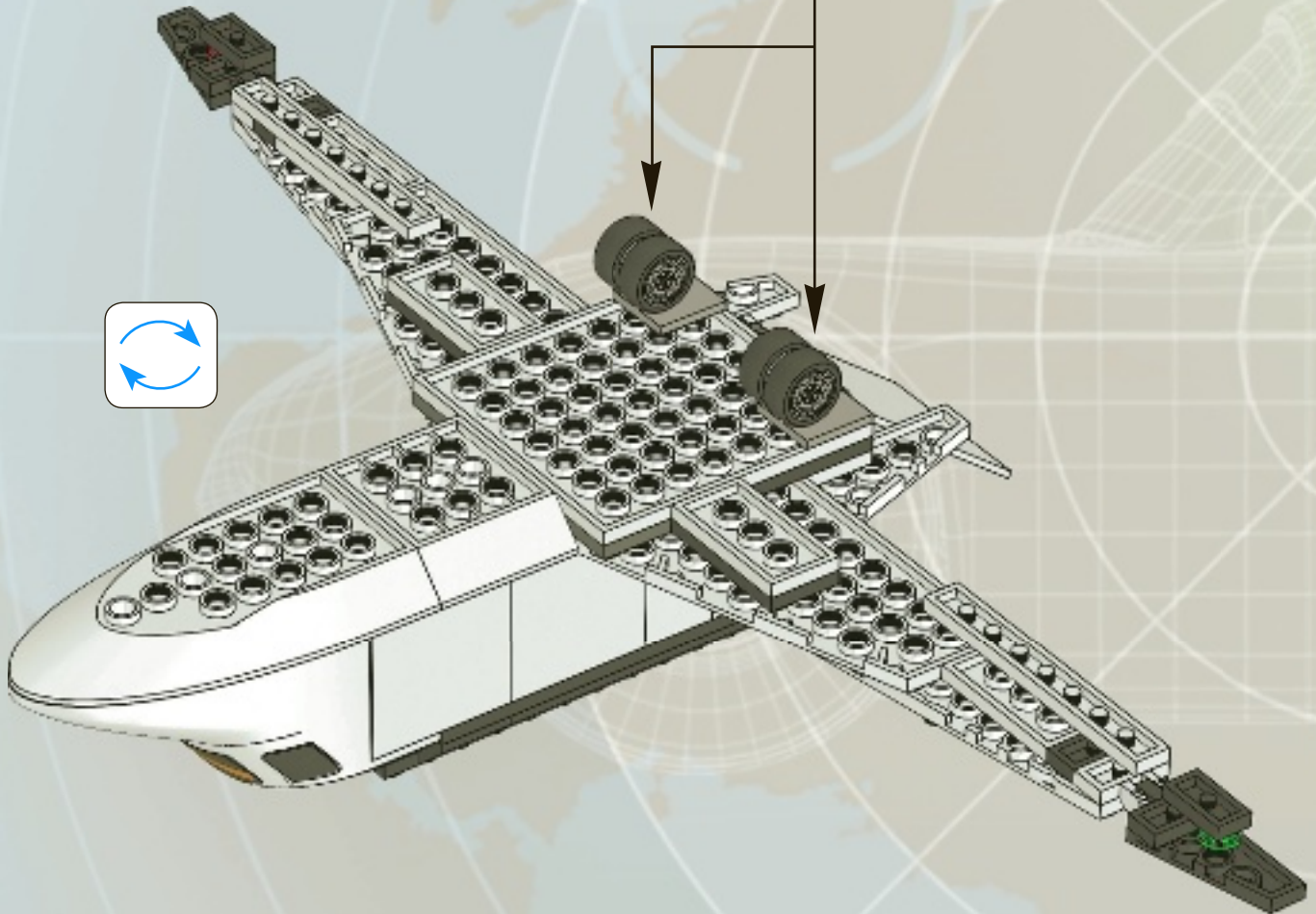
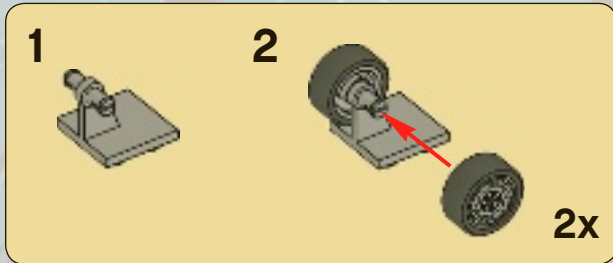



2x

30



2x

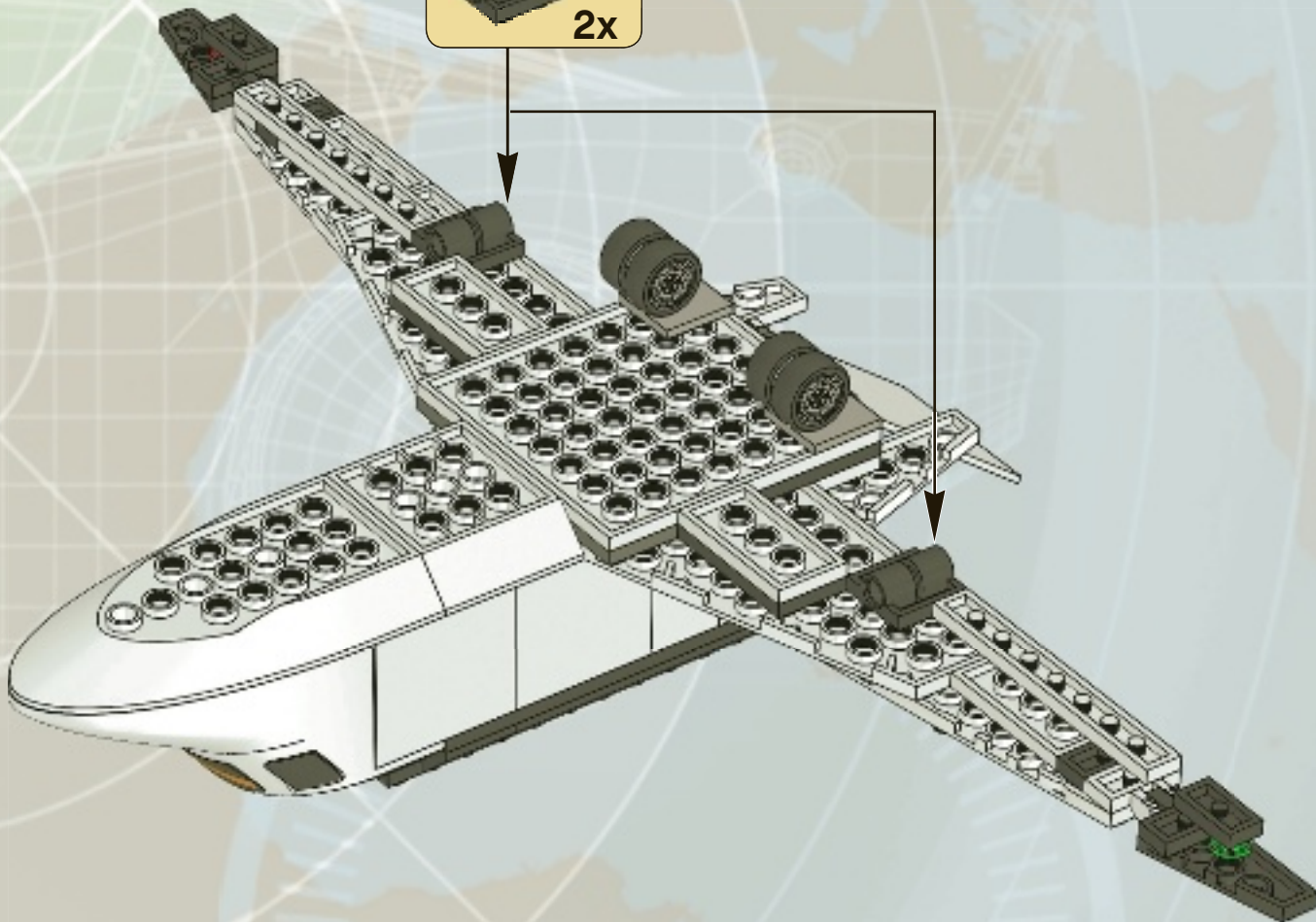



31

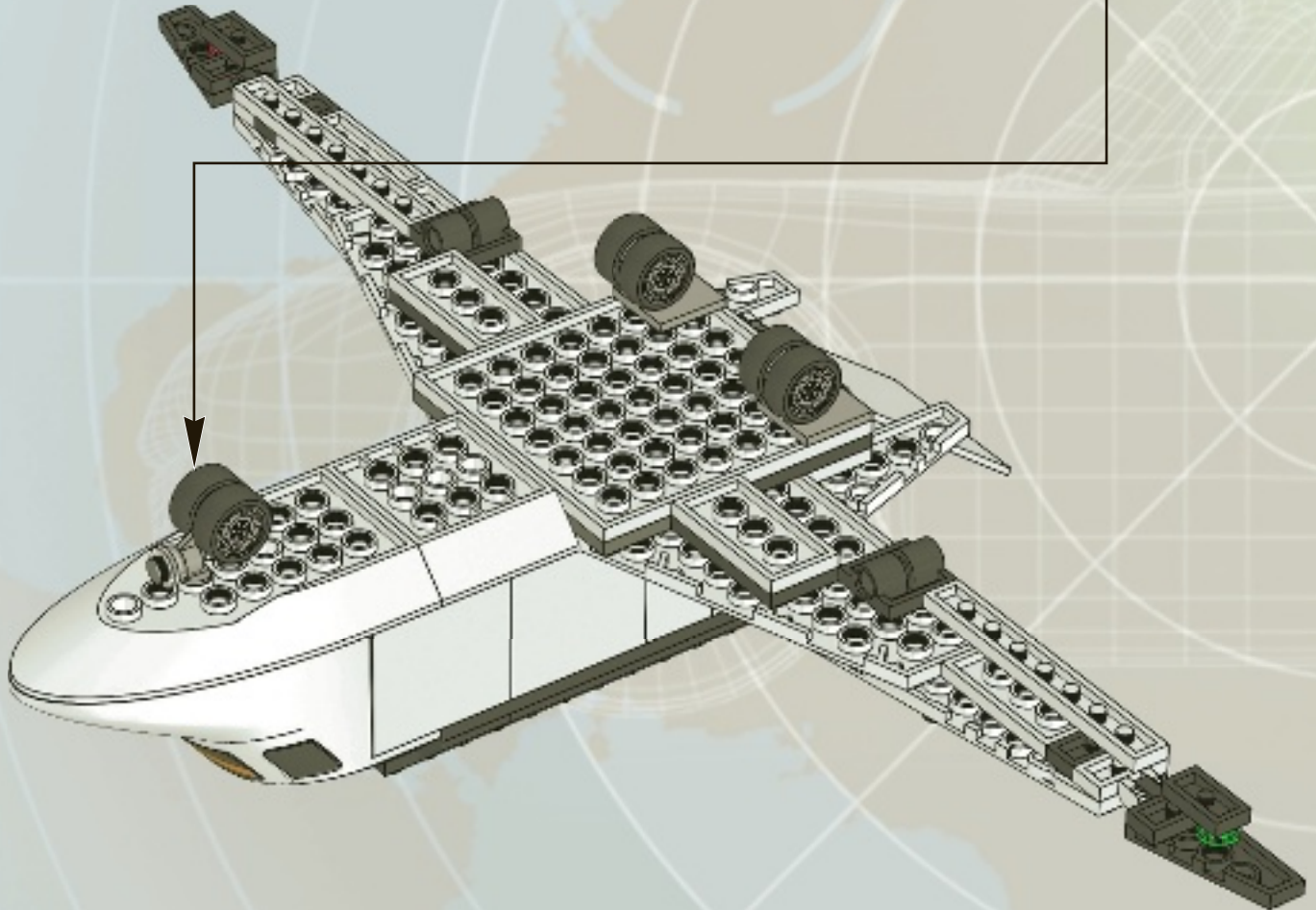
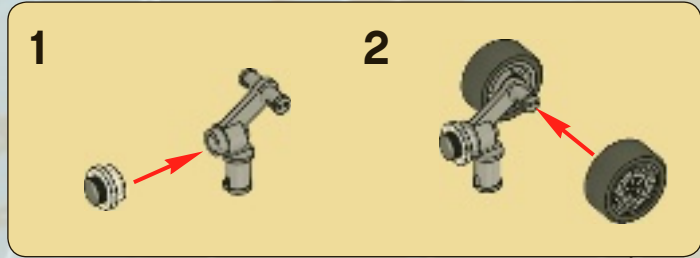



2x



2x

32

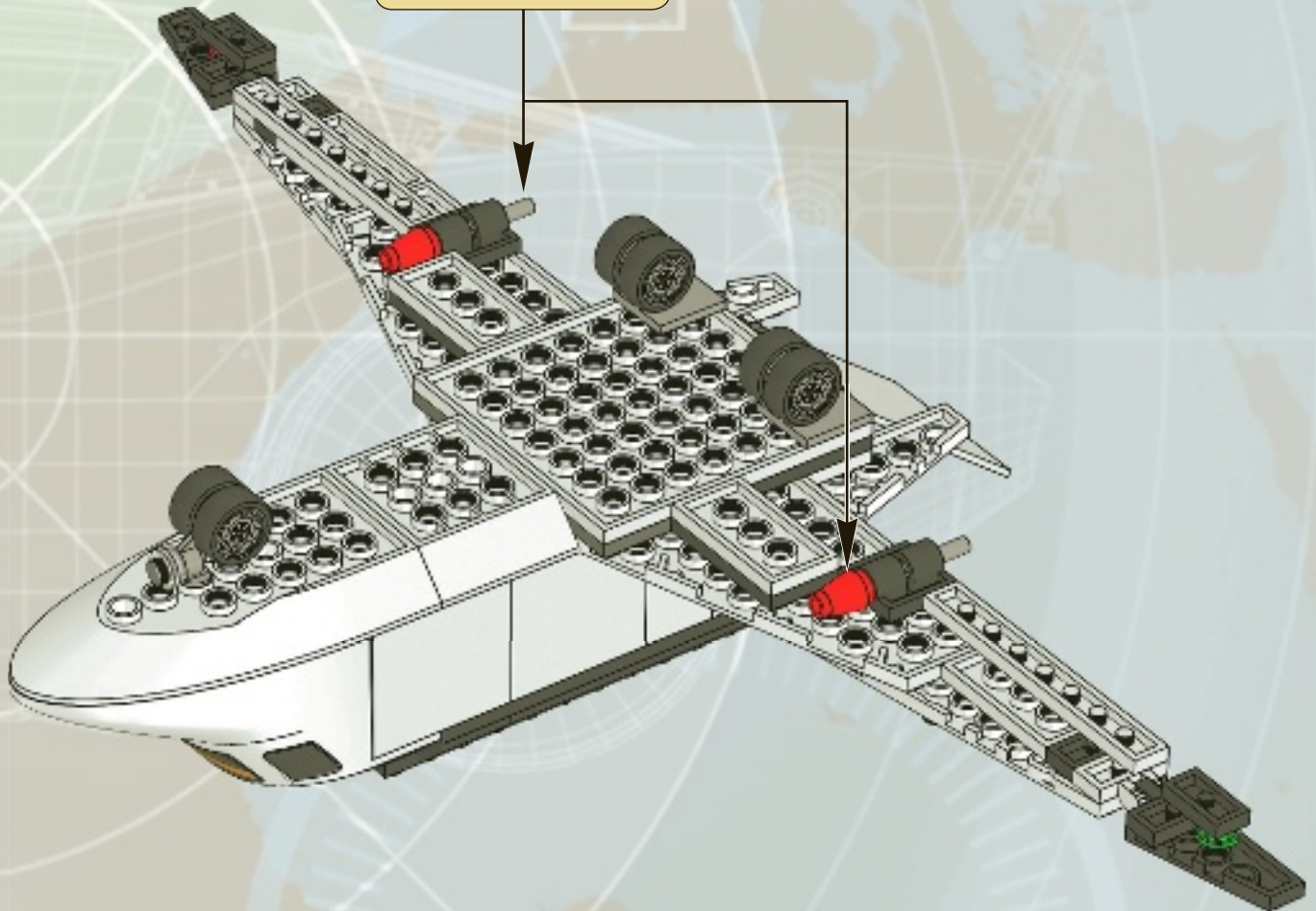
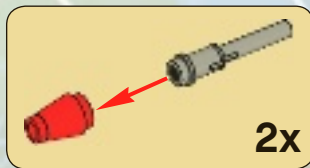

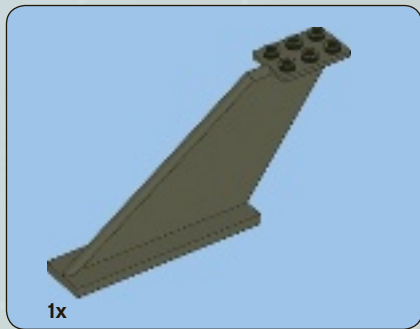
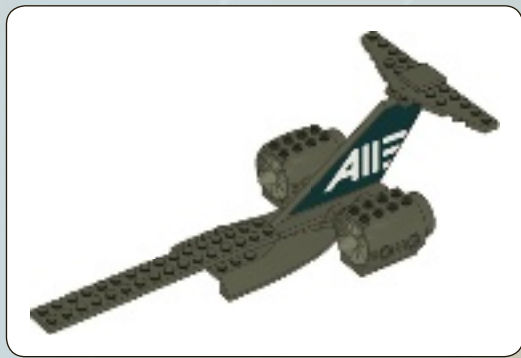

1



2

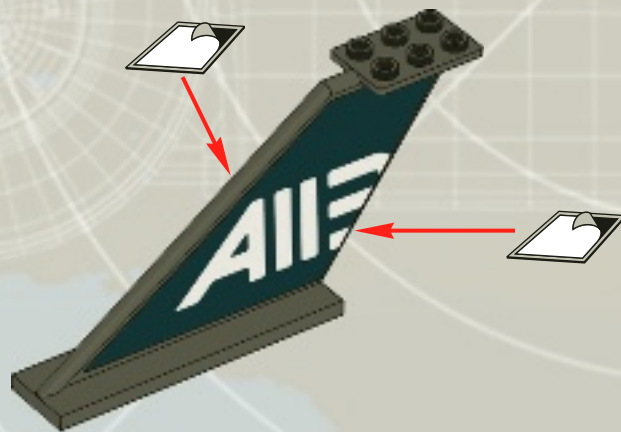

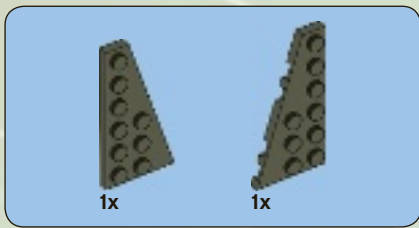

3



4

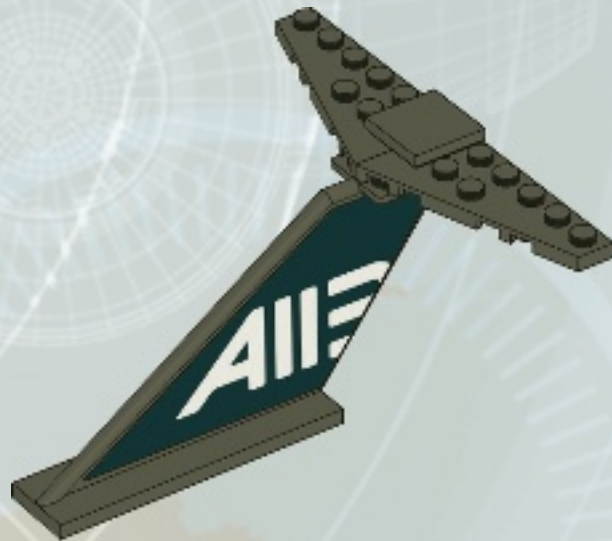

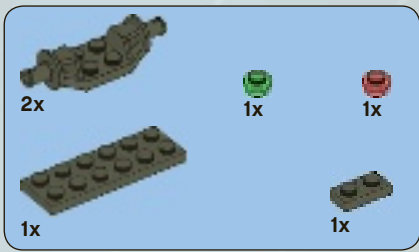

5

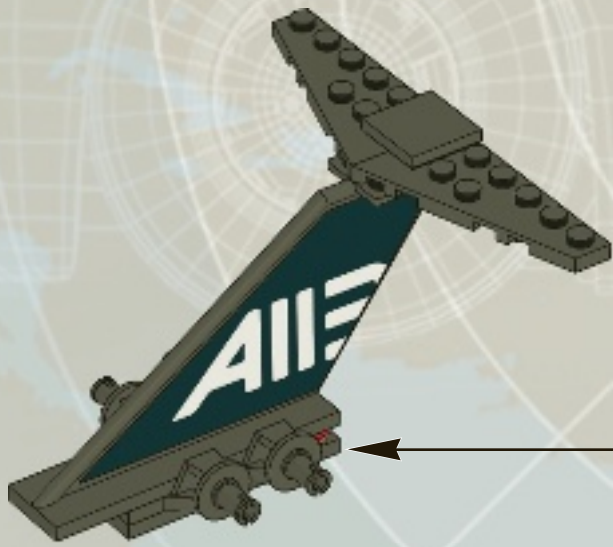
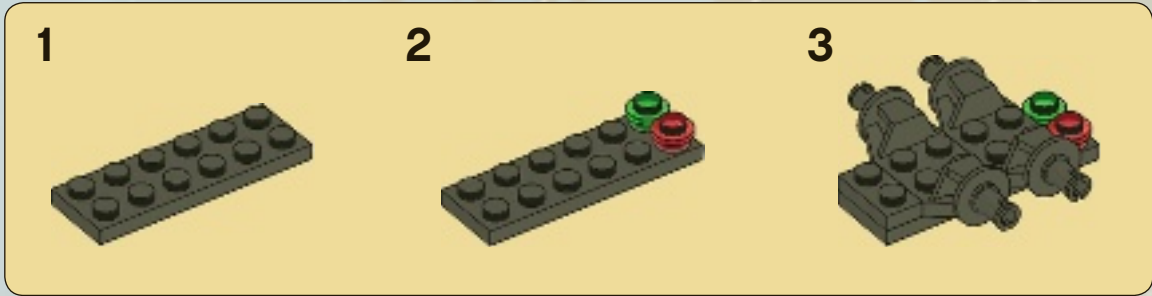



6

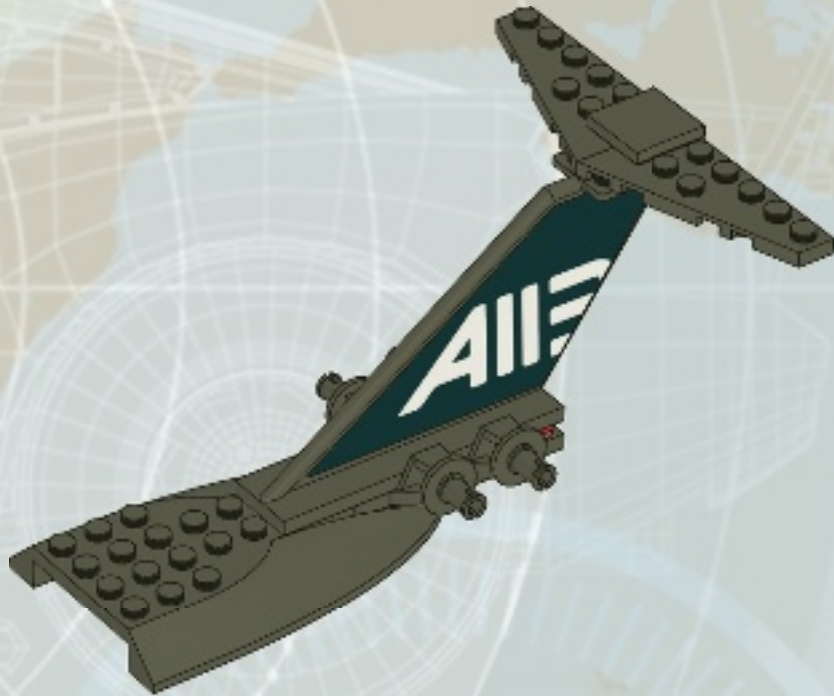

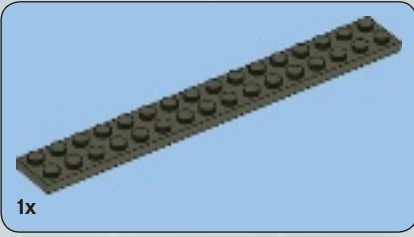

1x

7

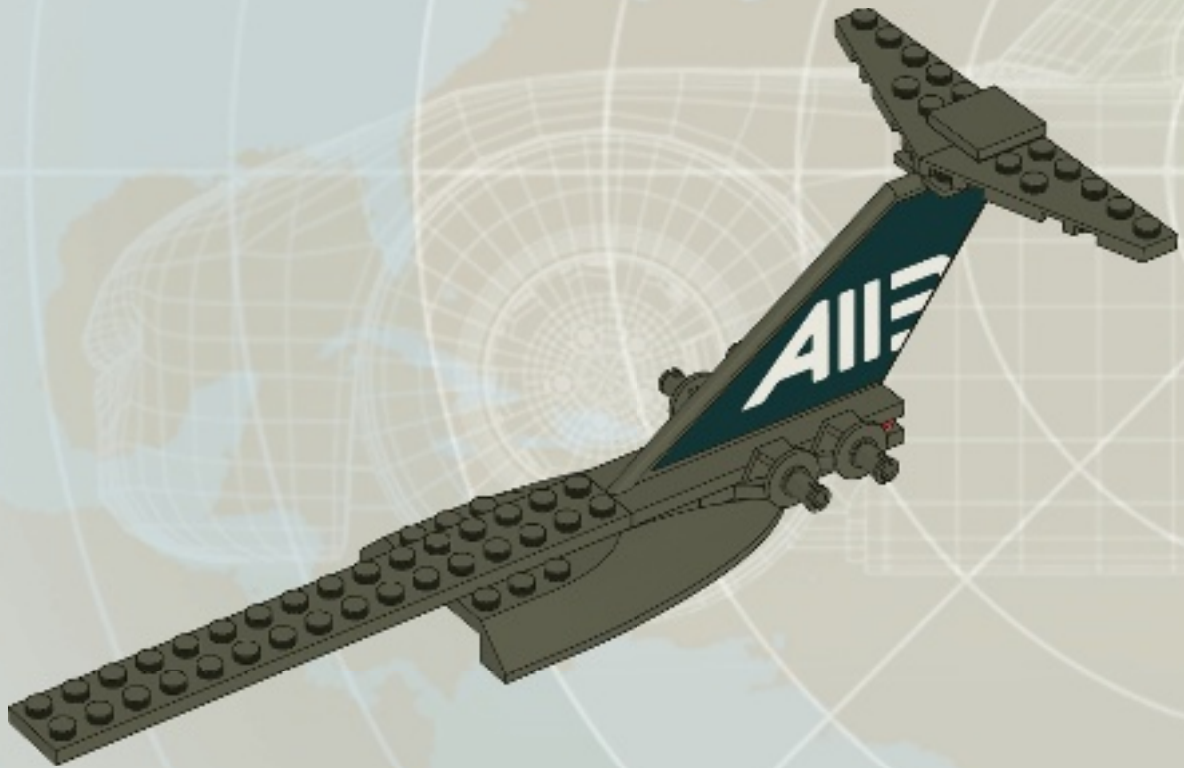

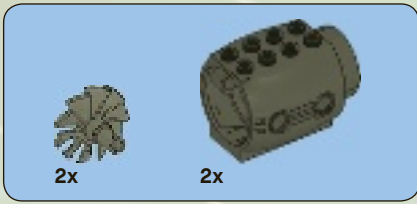

8

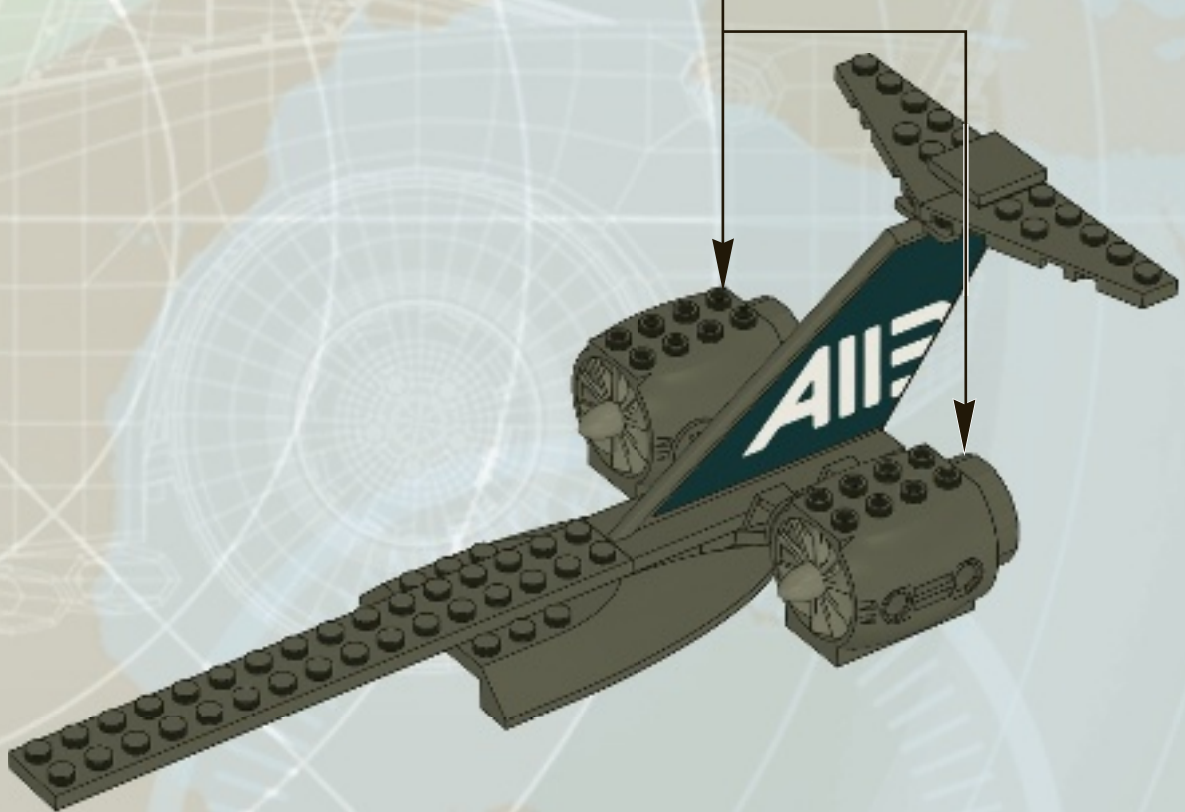
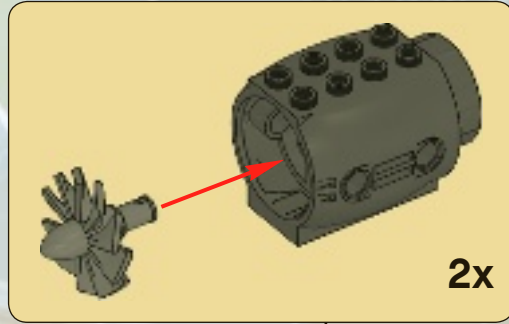

waypoint 1

33

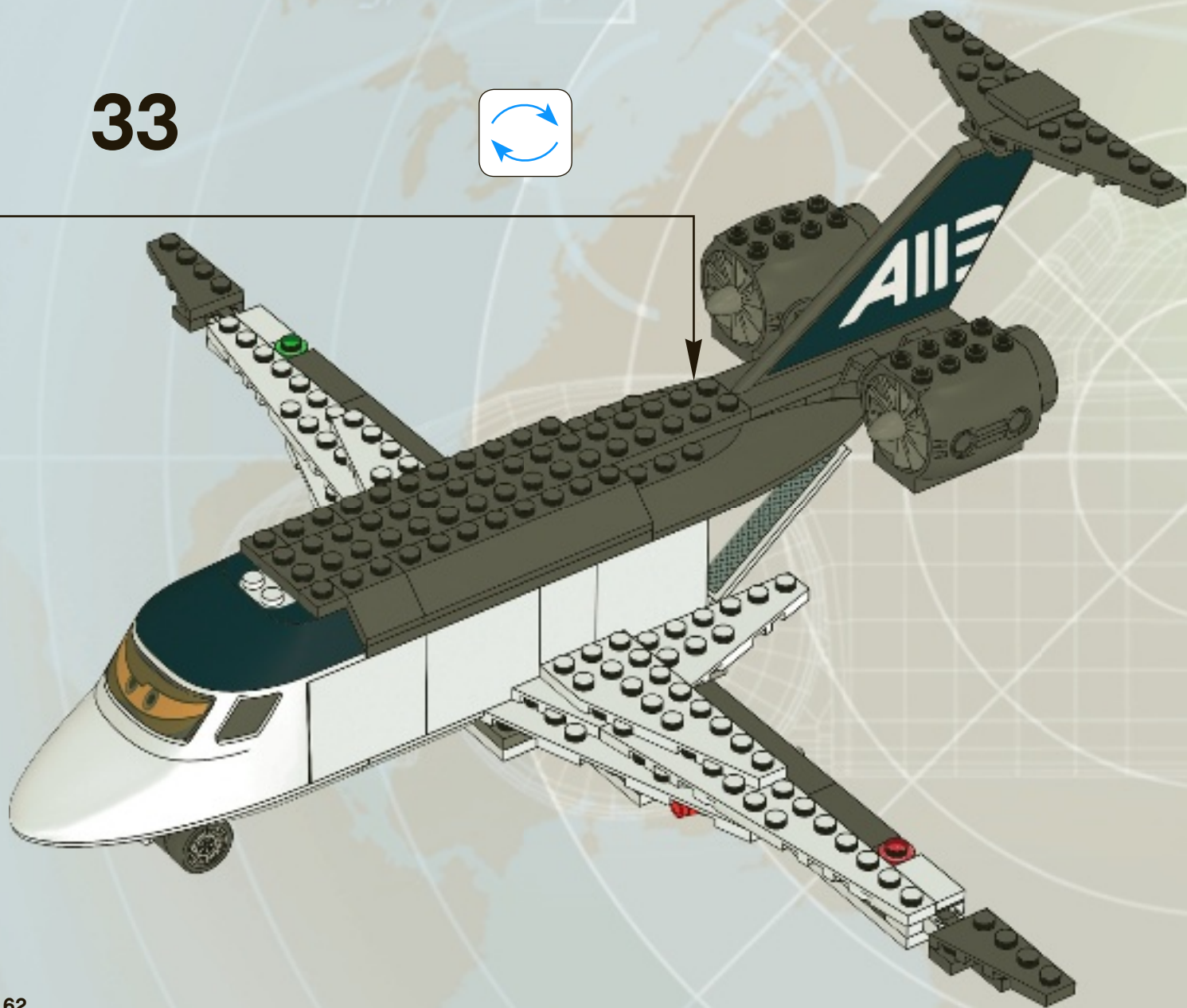

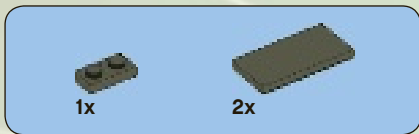

34



35

waypoint 1

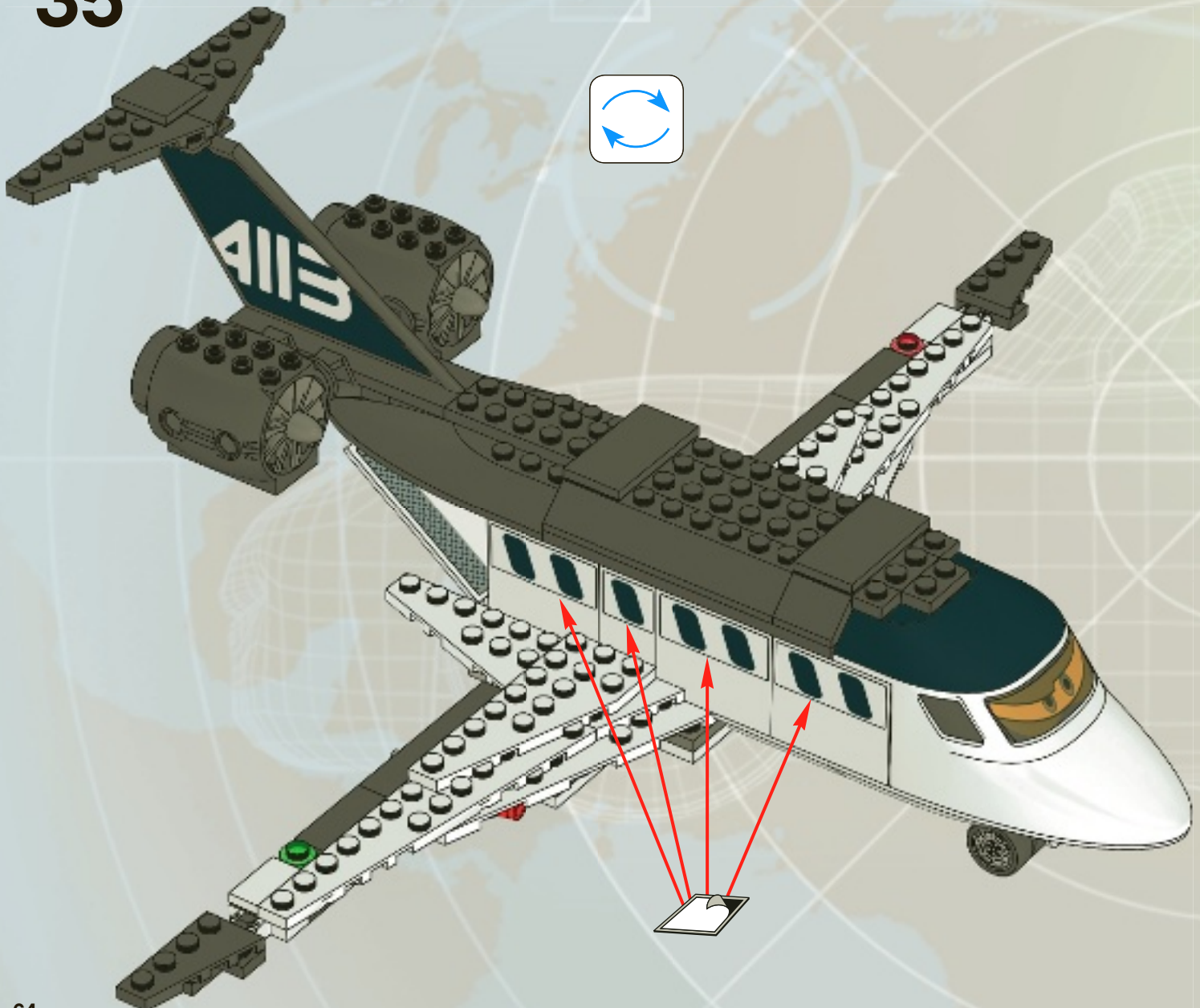
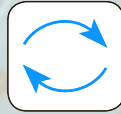

target
acquired

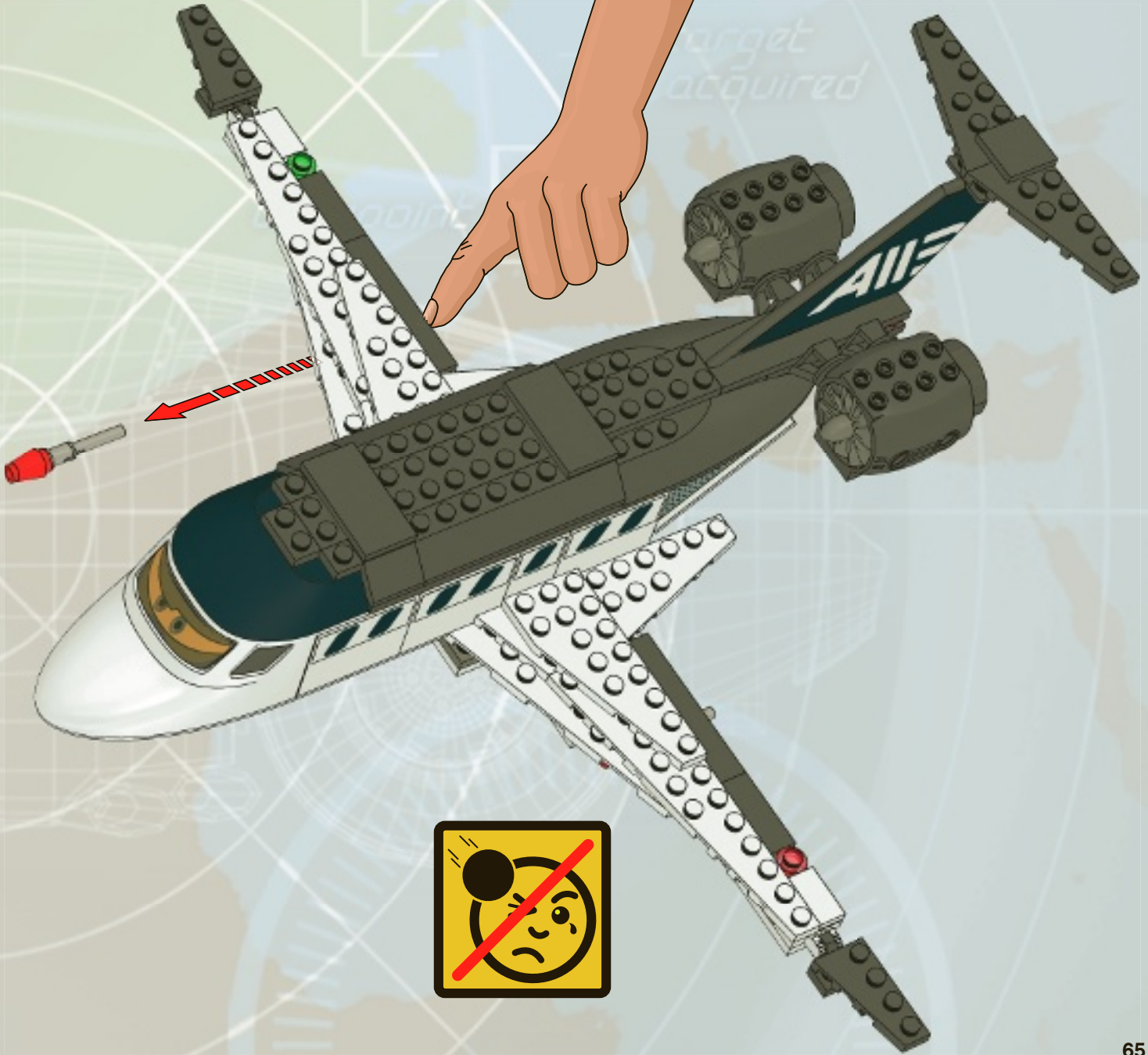

aypoint



1

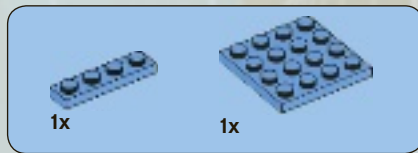
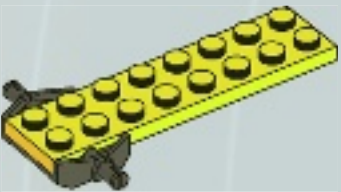

2

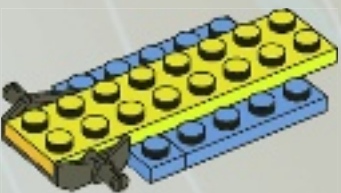

3

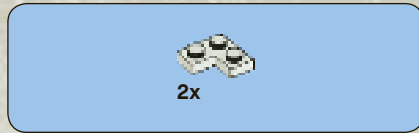
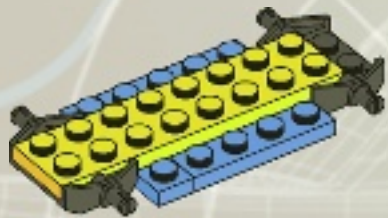

4





5

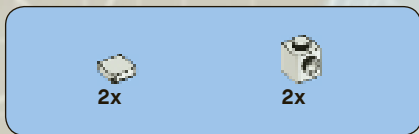
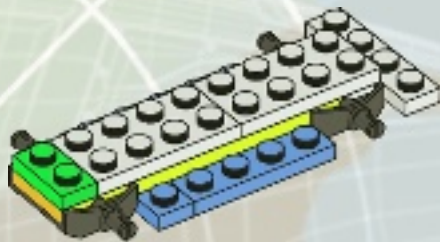

6

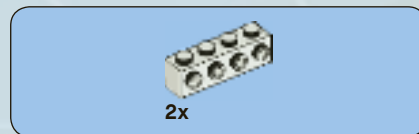
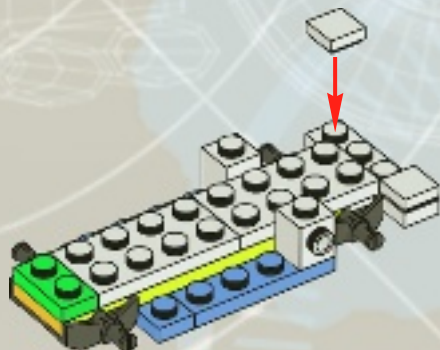

7

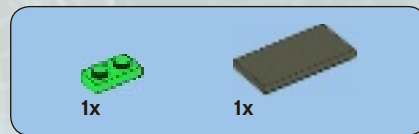
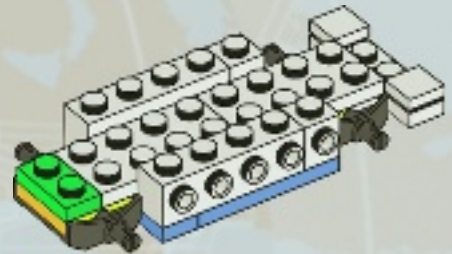

8

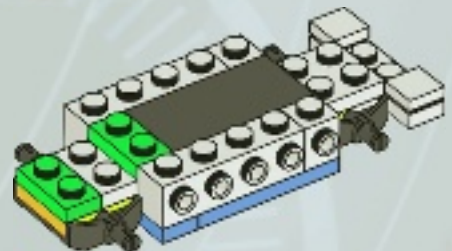



9

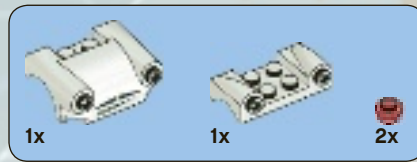
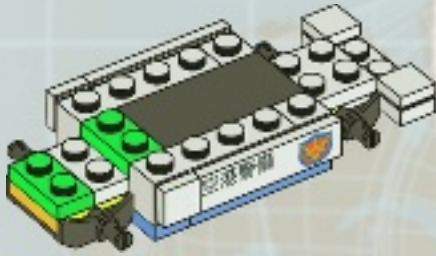

10

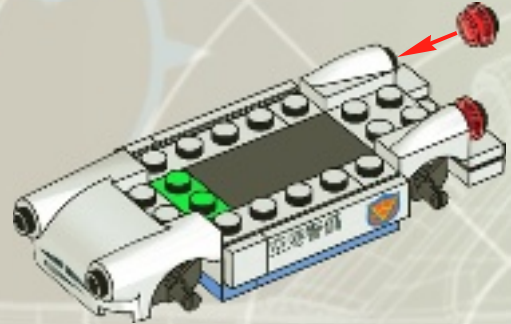

11

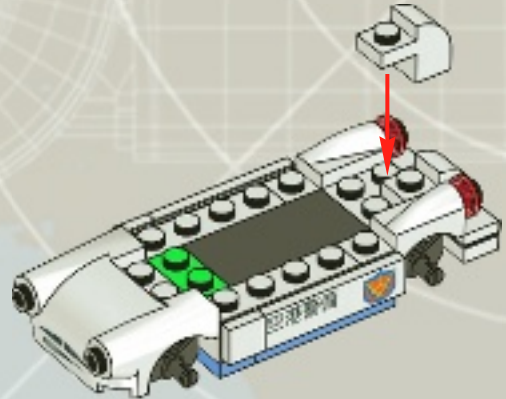



2x



2x

12

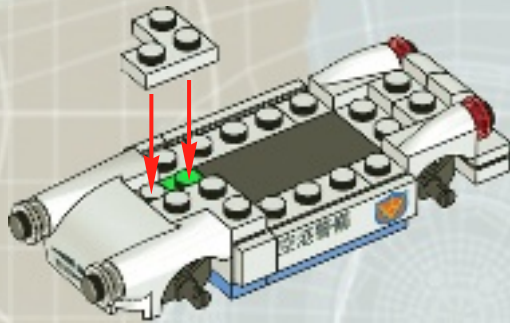

1x

13

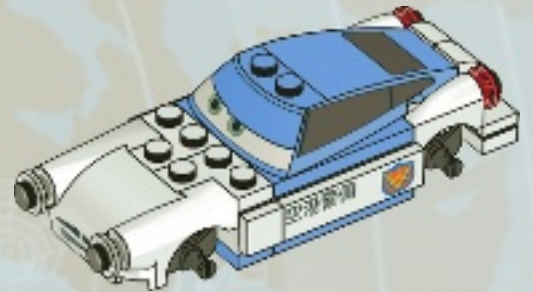

1x



4x



4x

14

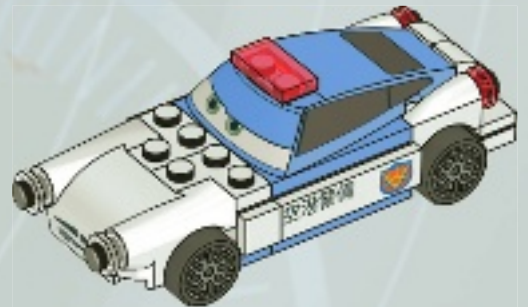



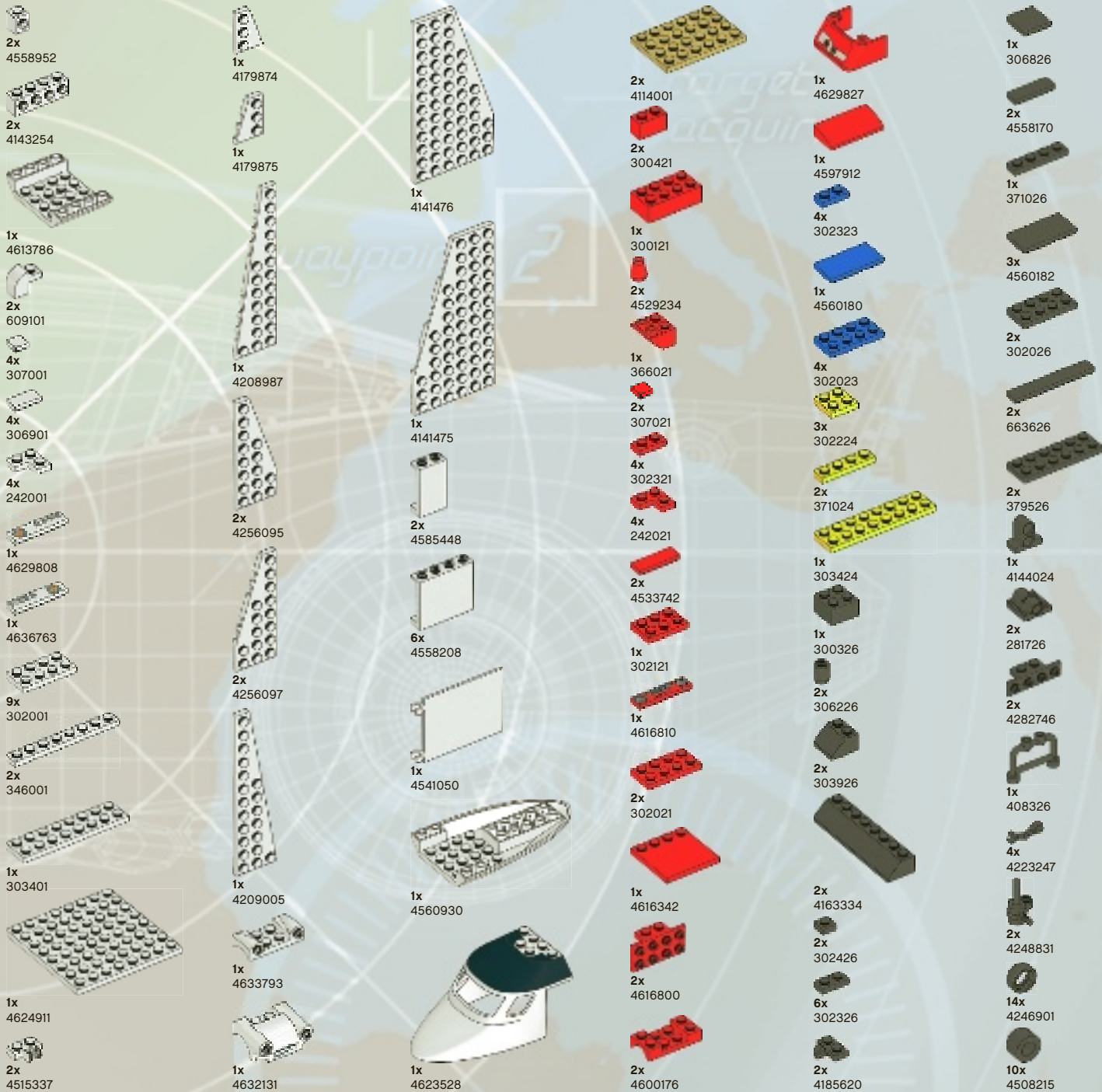



4x
4616406

2x
4516843

2x
447726

2x
428226

1x
4623524

1x
4623524

1x
4623525

2x
4295395

2x
244126

1x
4283047

1x
4283046

1x
4623527

1x
4160869

1x
4161332

2x
4217725

2x
4121715

2x
4217725

2x
302328

6x
3005740

2x
3000841

1x
4189801

7x
3005741

3x
3005748

1x
4622713

1x
4616408

1x
4179828

1x
4616698

1x
4121739

2x
4211386

2x
4211393

2x
4521921

1x
4260409

1x
4211414

3x
4211397

1x
4211356

1x
4211350

2x
4211516

1x
4211504

8x
4211765

10x
4621178

1x
4519013

2x
4520320

1x
4617072

1x
4518611

4x
4633822

1x
4187743

1x
4537936

1x
4617067

2x
4600186

1x
4617076

2x
4164022

1x
4617077

2x
4597561

2x
4621177

2x
421182

1x
4623160

2x
4621180

1x
4243826

1x
4621175

1x
4621184

1x
4222960

2x
4616701

2x
4620075

2x
4221744

2x
4211151

1x
4211152

1x
4616707

1x
4620530

2x
4221590

2x
4617030

2x
4616702

2x
4620534

2x
4620537

1x
4613134

1x
4629817

2x
4210997

2x
4295253

2x
4211085

4x
4211121

2x
4211043

1x
4211001

2x
4539429

2x
4587212

2x
4210660

1x
4620079

2x
4211051

1x
4212529

1x
4523398



Customer Service
Kundenservice
Service Consommateurs
Servicio Al Consumidor

www.lego.com/service or dial



00800 5346 5555 : 

1-800-422-5346 : 



LEGO.com/CARS



8639



8487





www.LEGOclub.com



LEGO® Club Email

LEGO club™

FREE! GRATIS! GRATUIT!



LEGO® Club Magazine

SIGN UP ONLINE!

www.LEGOclub.com



00800 5346 5555*



1-866-534-6258 • 1-877-518-5346

US & Canada only

Canada seulement

* Freephone. Mobile charges may apply.
* Numéro sans frais. Des frais peuvent s'appliquer avec les téléphones cellulaires.
* Gebührenfrei, Kosten für Anrufe aus Mobilfunknetzen können abweichen.
* Gratis telefonnummer vanaf vaste lijn.
* Det er et gratis nummer, når du ringer fra fasttelefon.
* Det är gratis, när du ringer från en fast telefon.
* Numéro sans frais. Des frais peuvent s'appliquer avec les téléphones portables.



WIN!

Go to www.LEGOsurvey.com/product to fill out a survey for a chance to win a cool LEGO® Product.
No purchase necessary.
Open to all residents where not prohibited.

 www.LEGO.com



www.LEGOsurvey.com/product

GEWINNE! WIN!

Nimm an der Umfrage auf www.LEGOsurvey.com/product teil und hab die Chance ein cooles LEGO® Produkt zu gewinnen!

Die Teilnahme am Gewinnspiel führt zu keinerlei Kaufverpflichtungen. Teilnahme in allen nicht ausgeschlossenen Ländern möglich.

Ga naar www.LEGOsurvey.com/product vul een enquêteformulier in en maak kans op een cool LEGO® product.

Geen aankoopverplichting. Iedereen mag deelnemen, uitgezonderd ingezetenden van landen waar een enquêteverbod geldt.

GAGNE! 当てよう!

Visite www.LEGOsurvey.com/product pour répondre à un questionnaire et avoir une chance de gagner un produit LEGO® très cool!

Aucune obligation d'achat. Ouvert à tous les résidents des pays autorisés.

www.LEGOsurvey.com/product にアクセスして、アンケートにご記入ください。当選者にはレゴ®製品を差し上げます。

お買い上げの必要はありません。
禁止されていない限り、すべての皆様にご利用いただけます。