



# PIRATES

6243



1

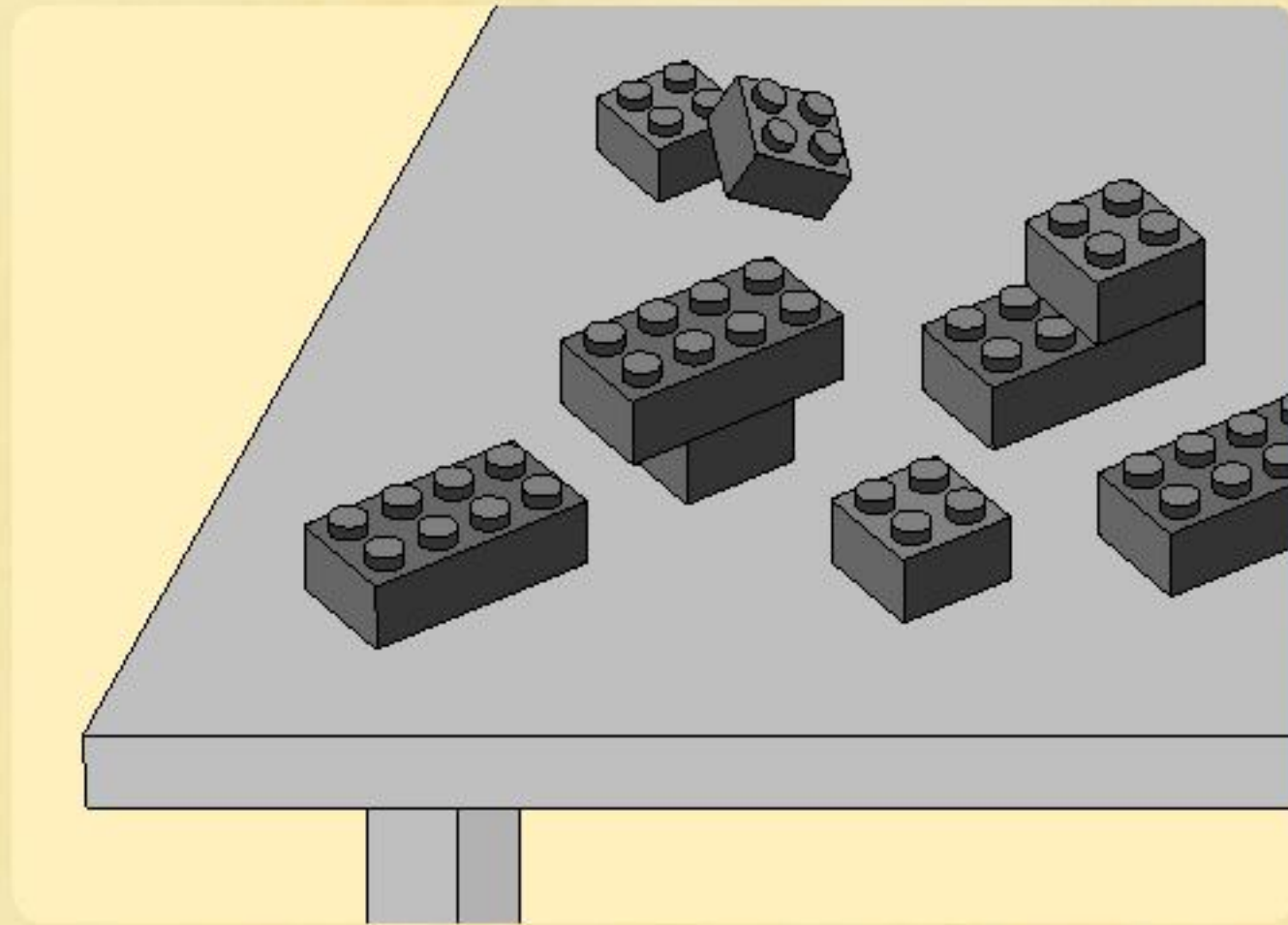
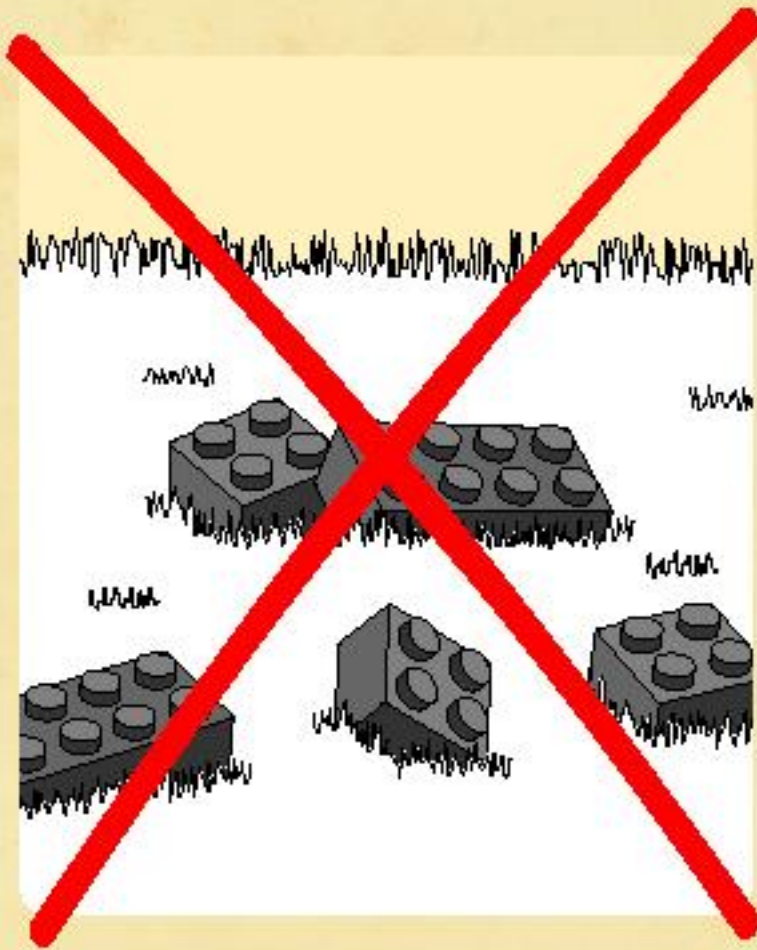

2





2x



2x



1x

+

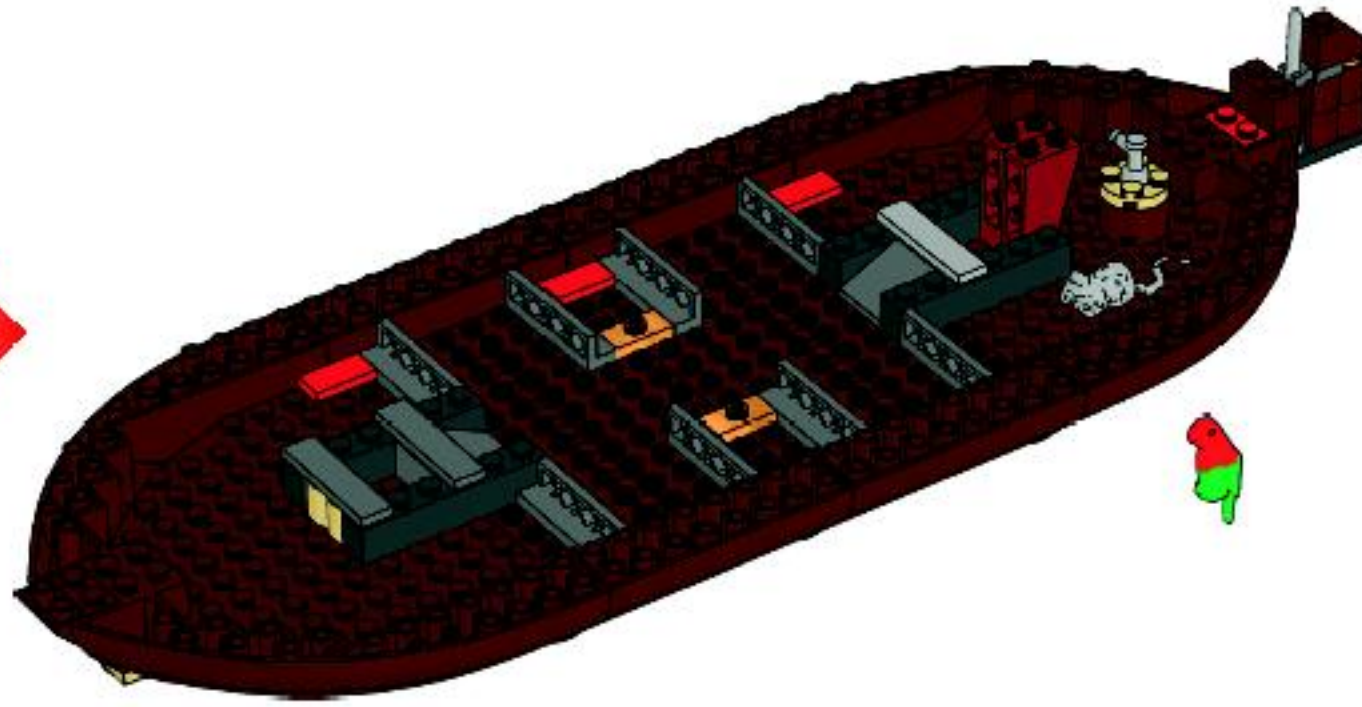

3

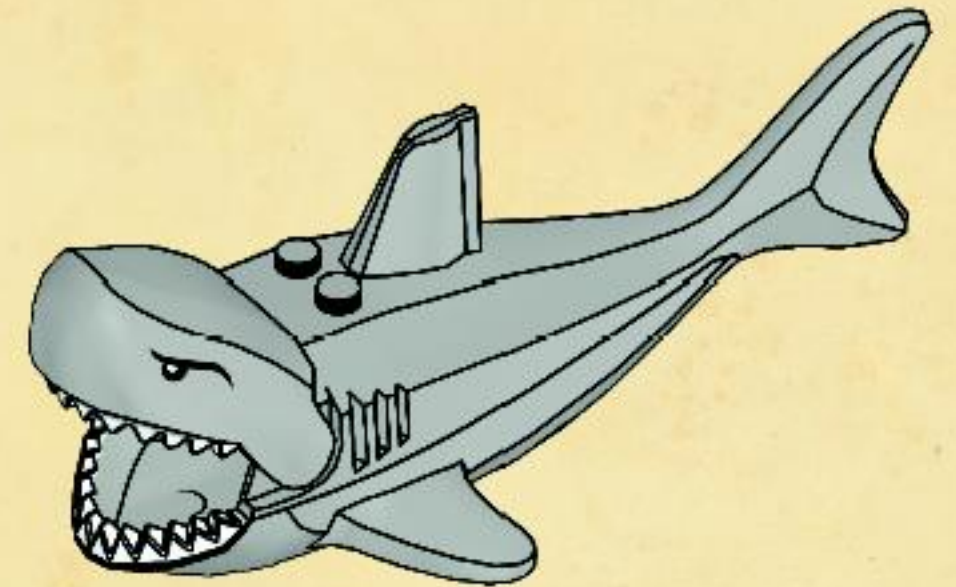

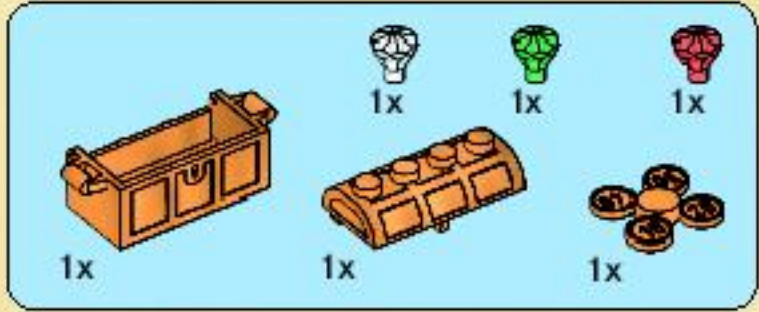

4

1



2

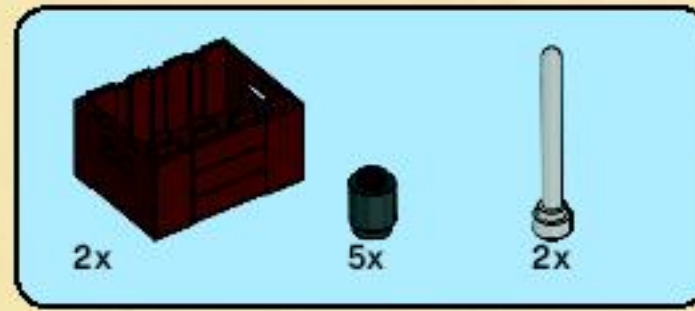

5



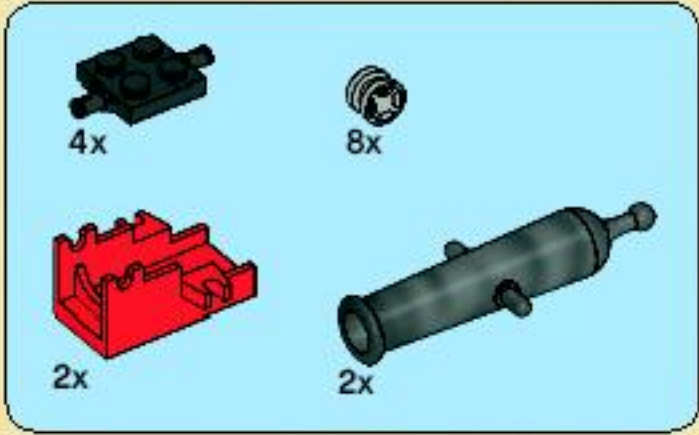

6

1

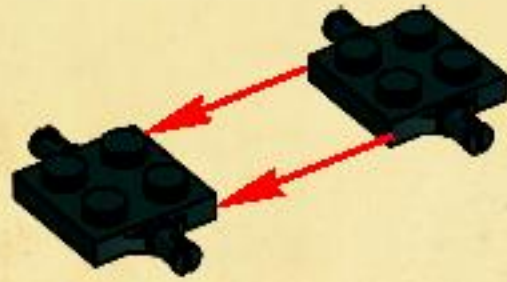

2

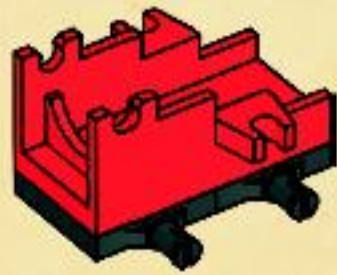

3

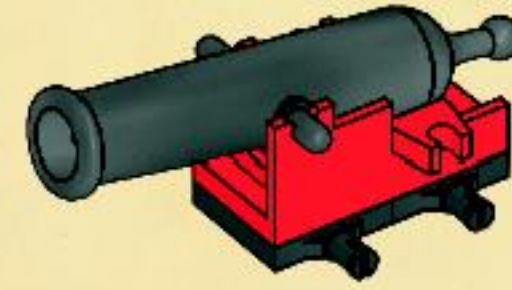

4

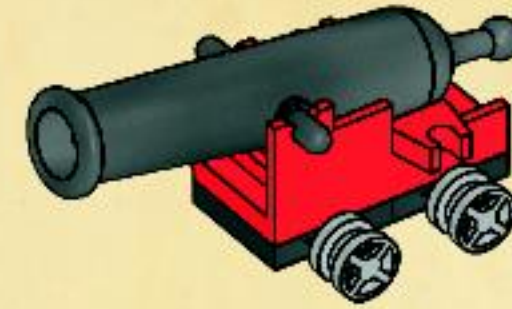

2x

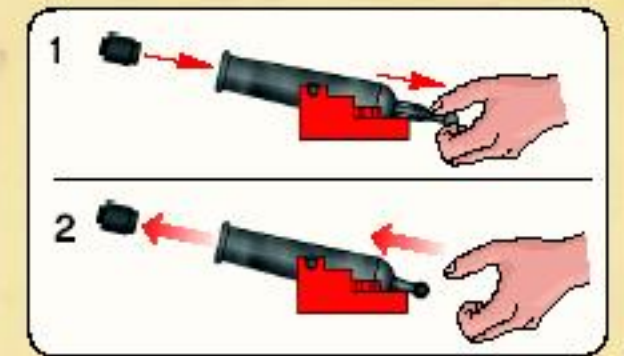



4

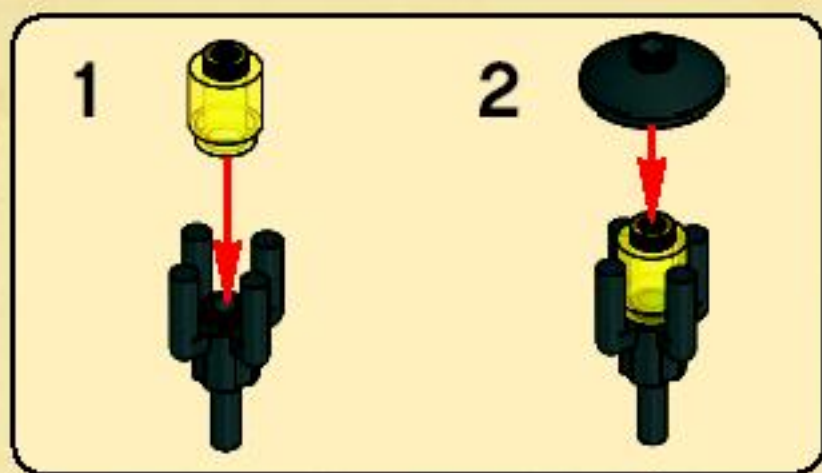
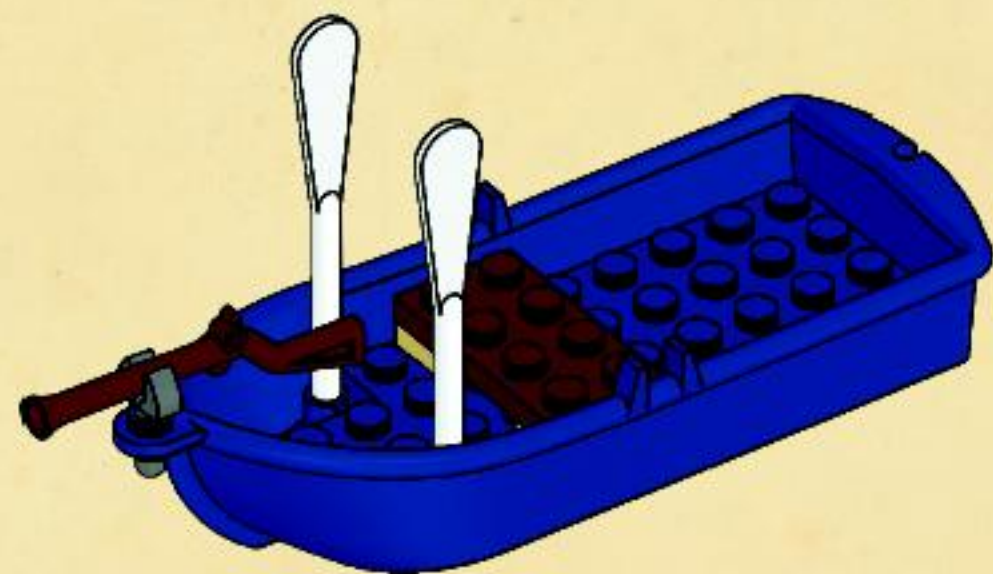

5

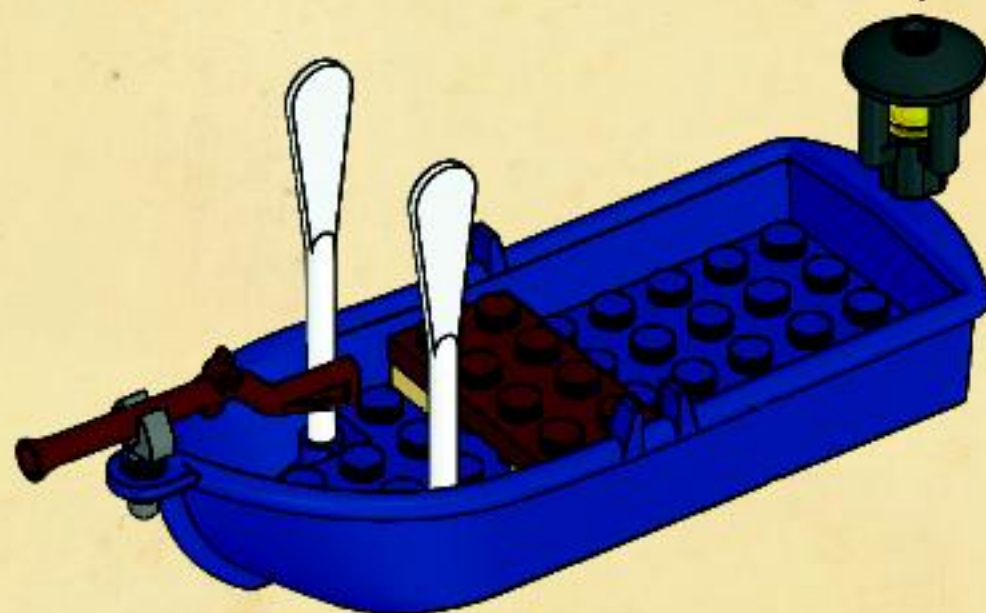

6



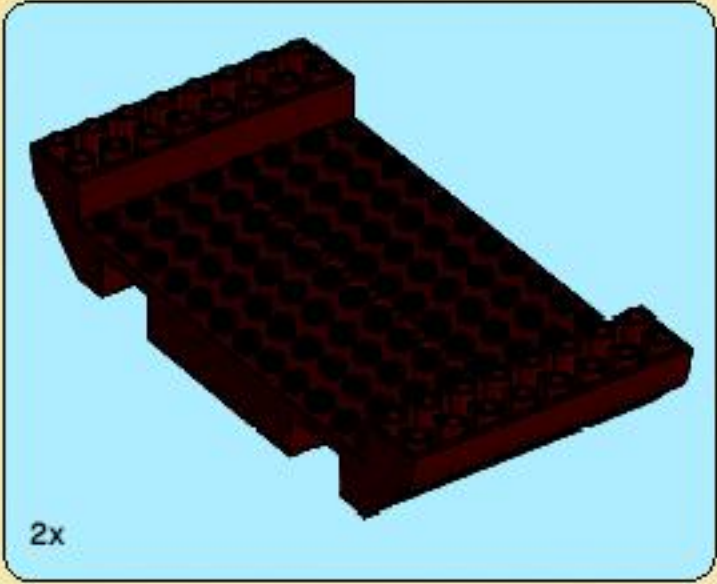
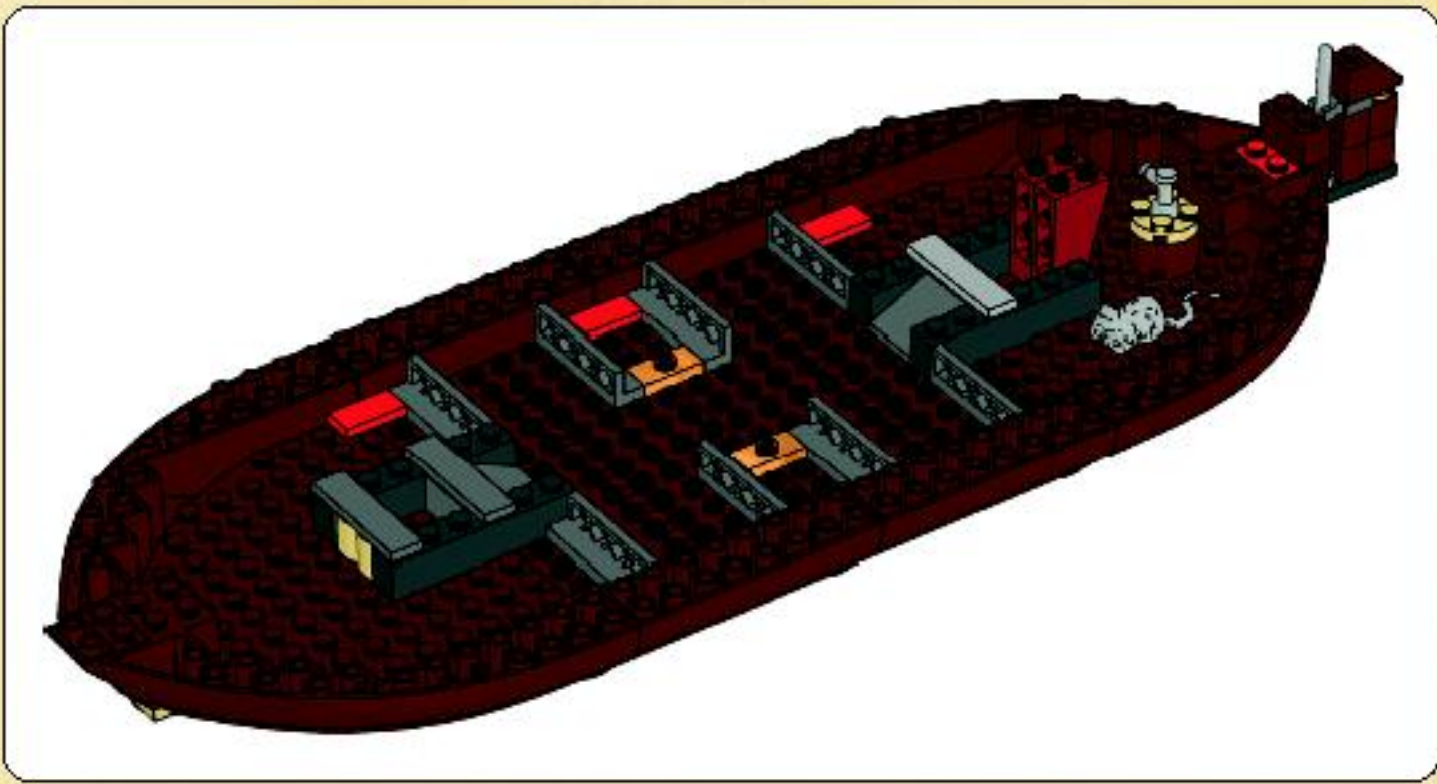

1

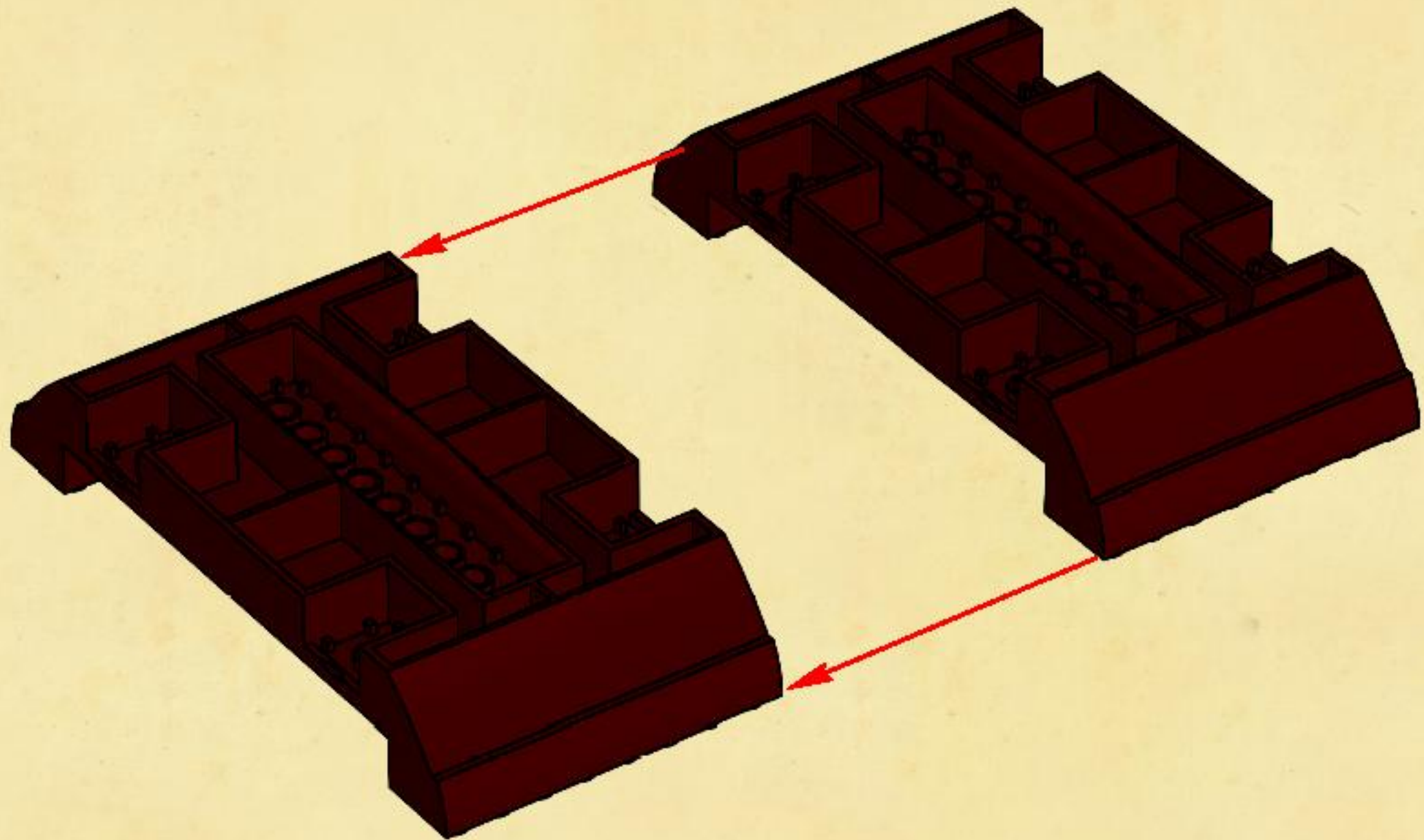



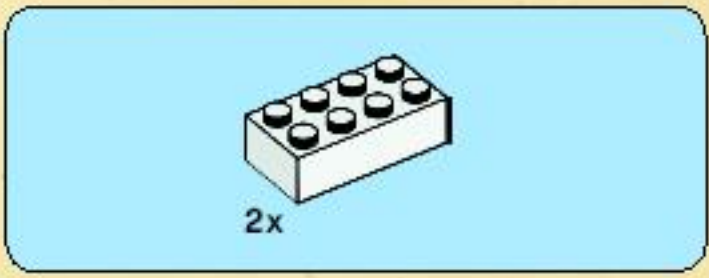

2

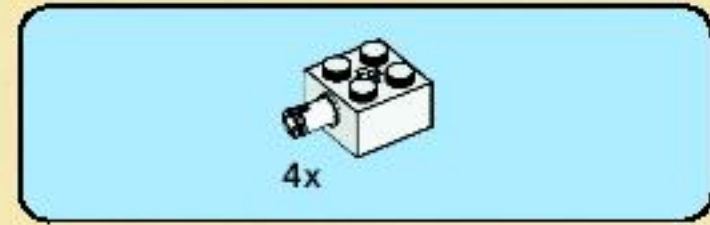
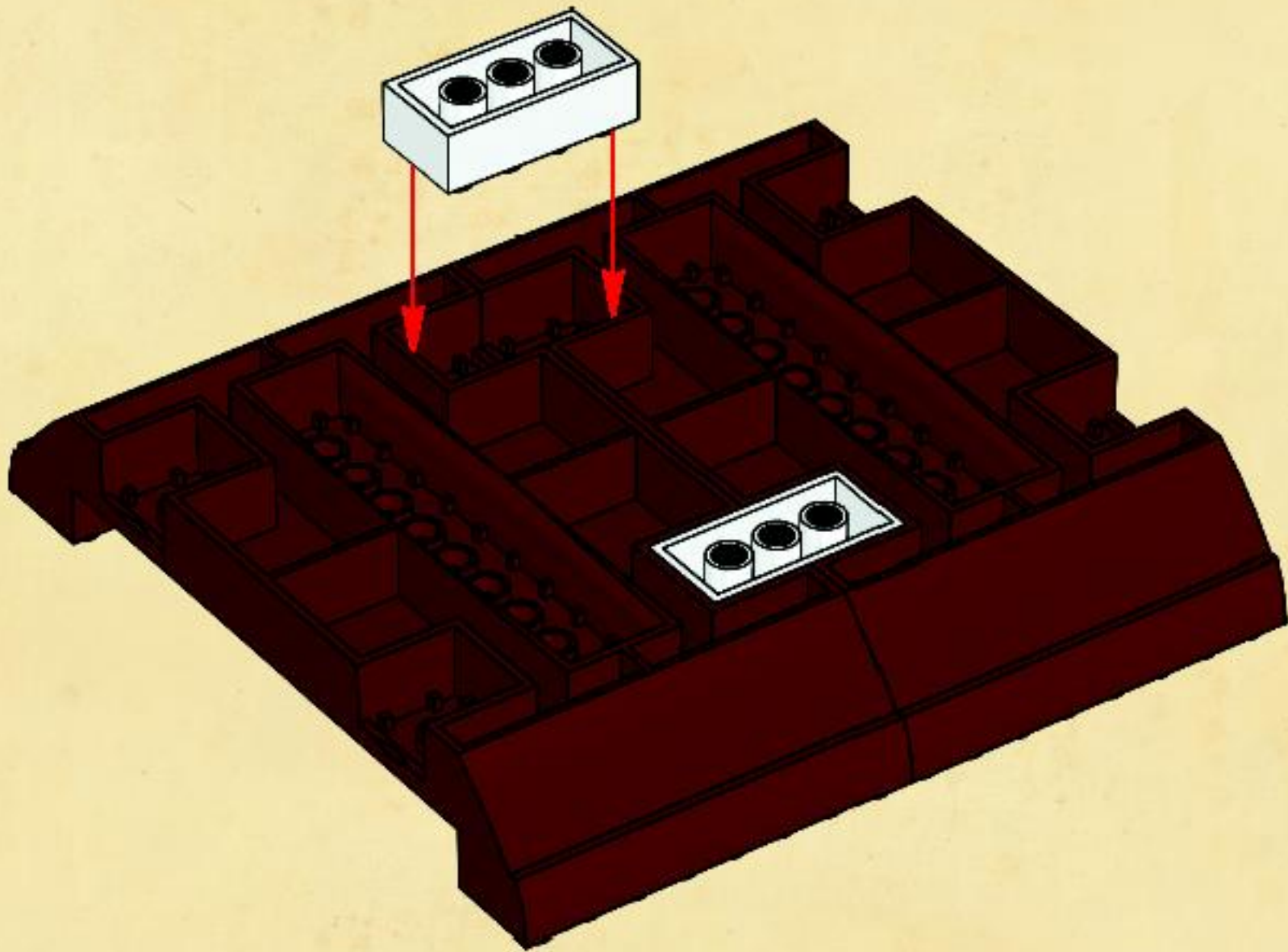

3

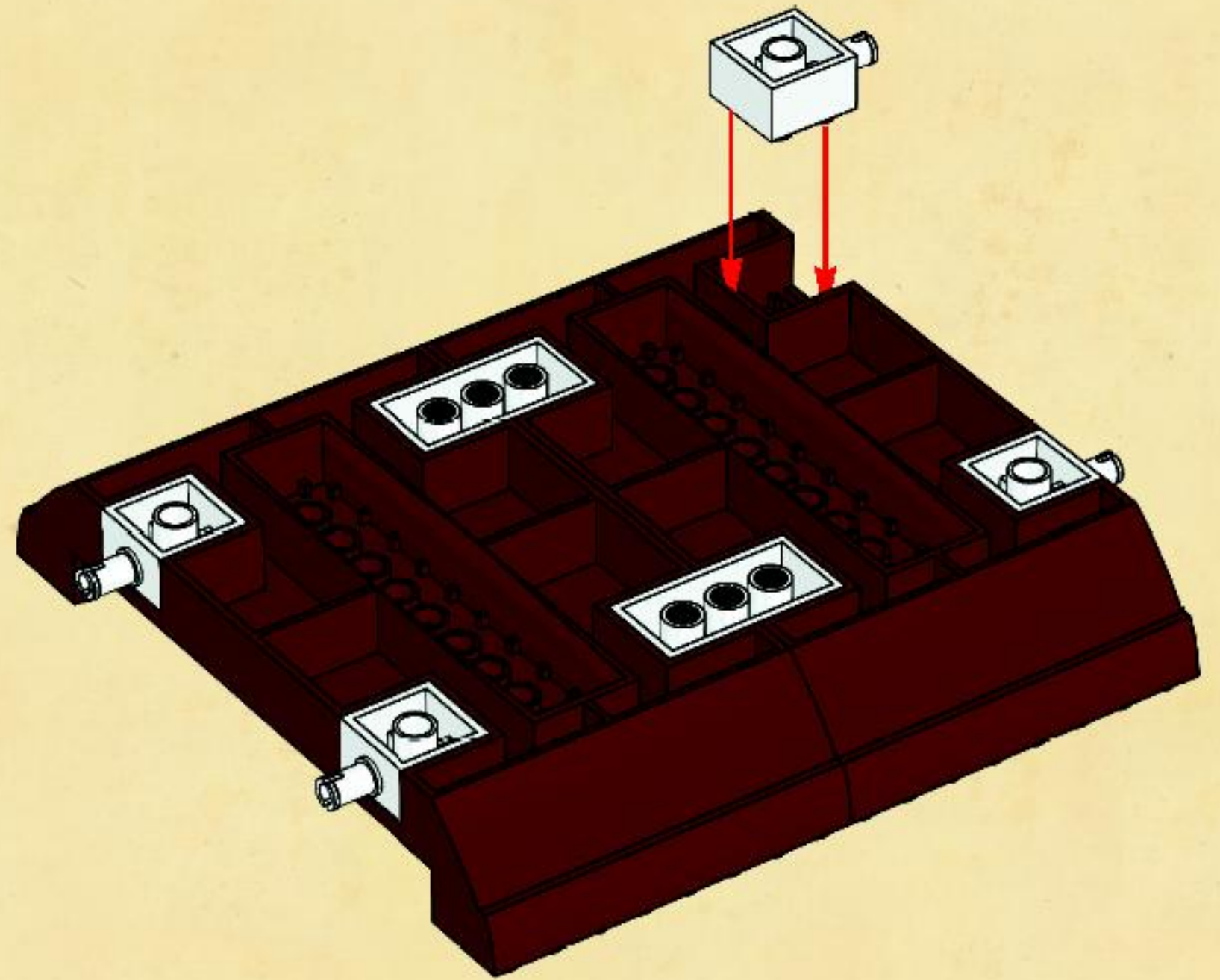



4

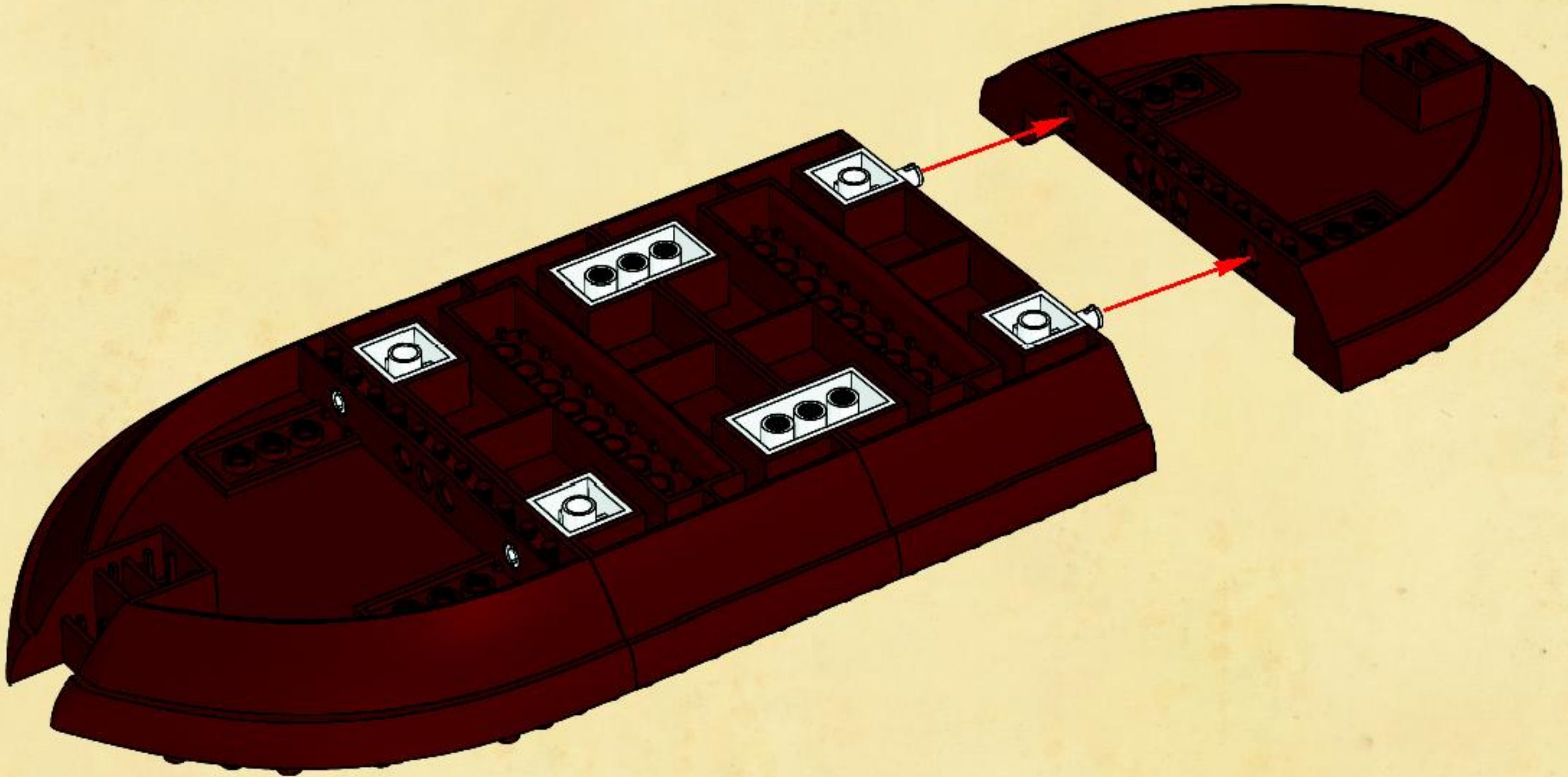



5

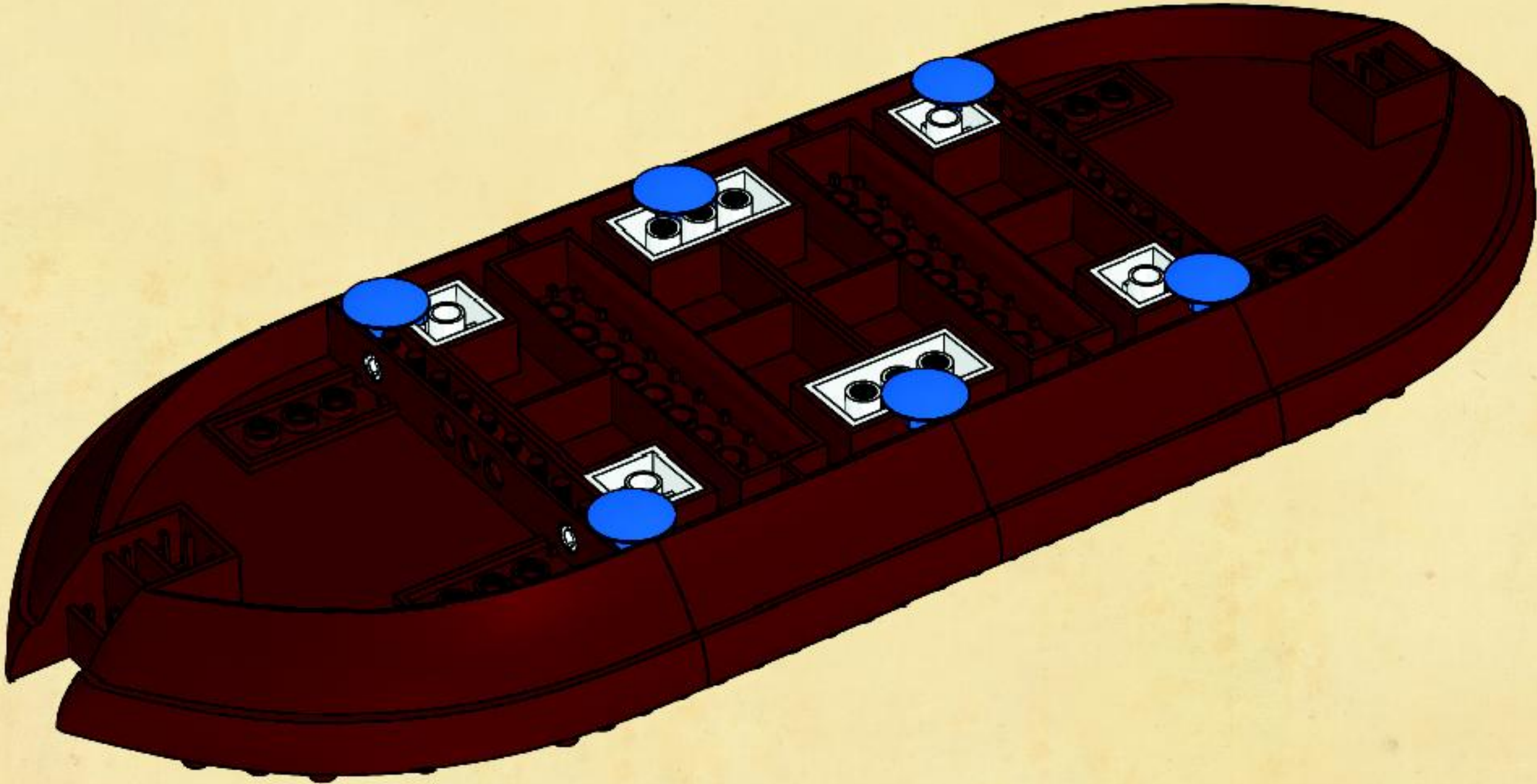

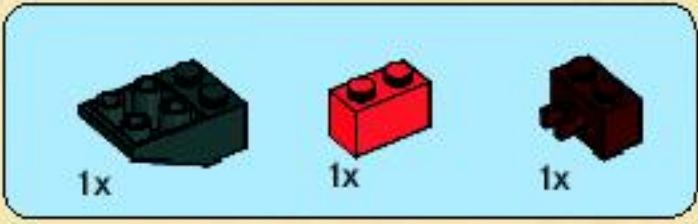

6

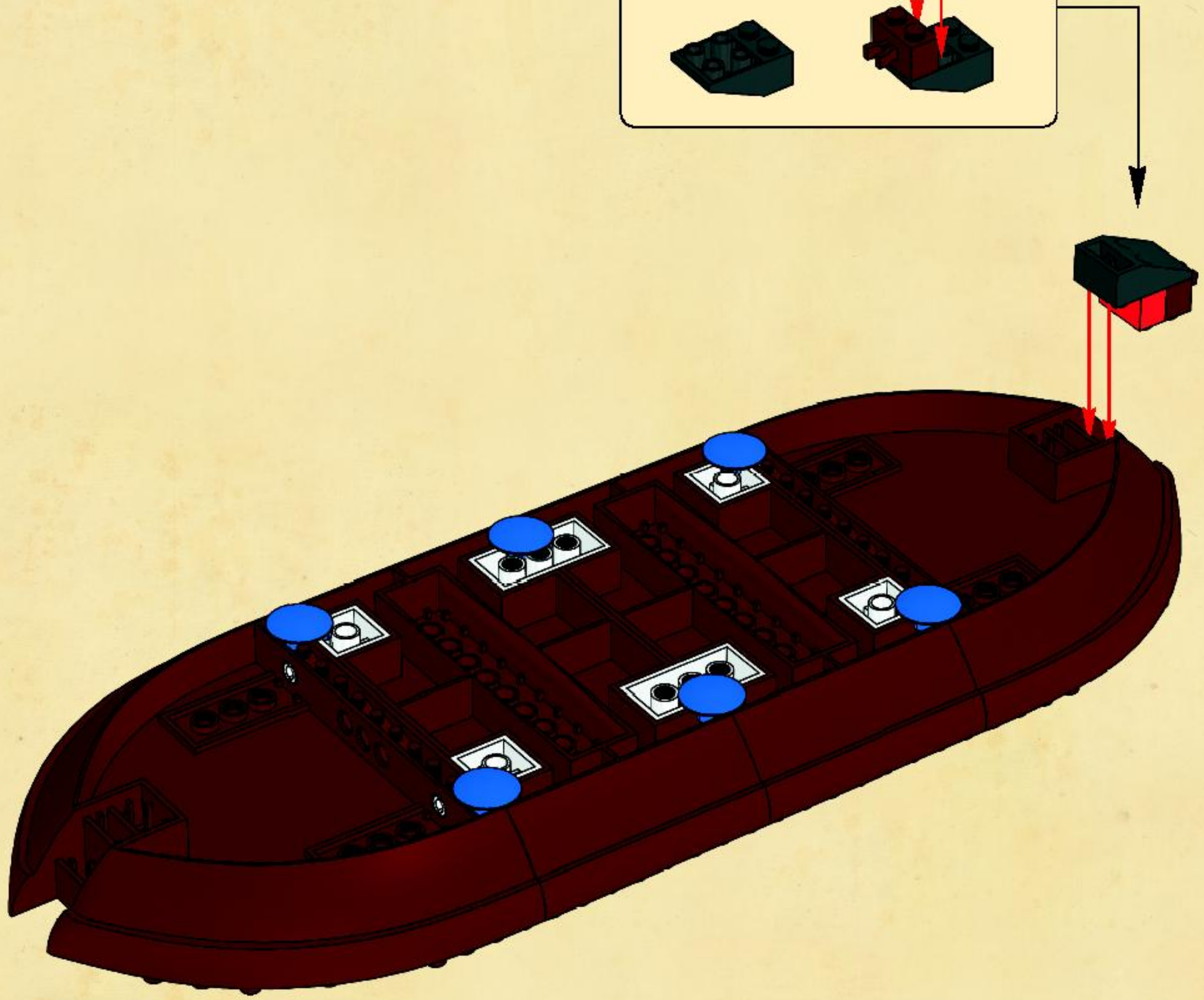
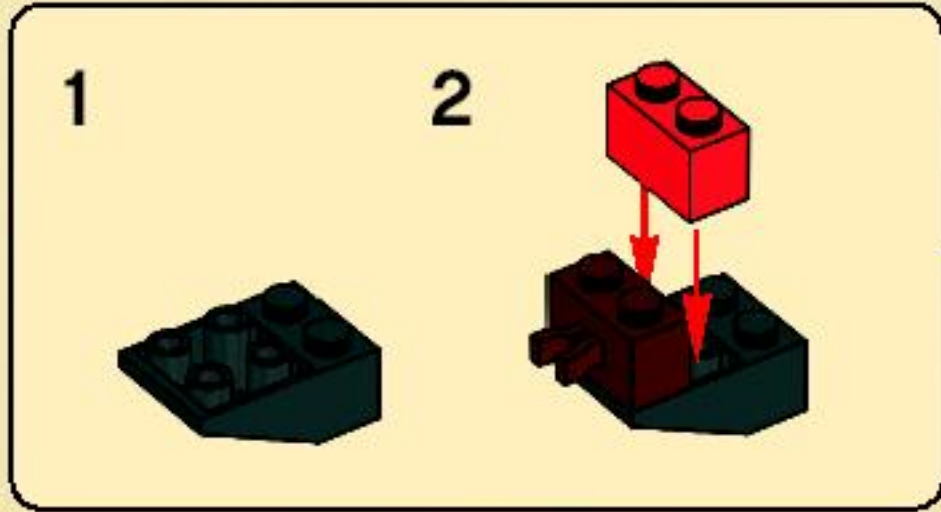



7

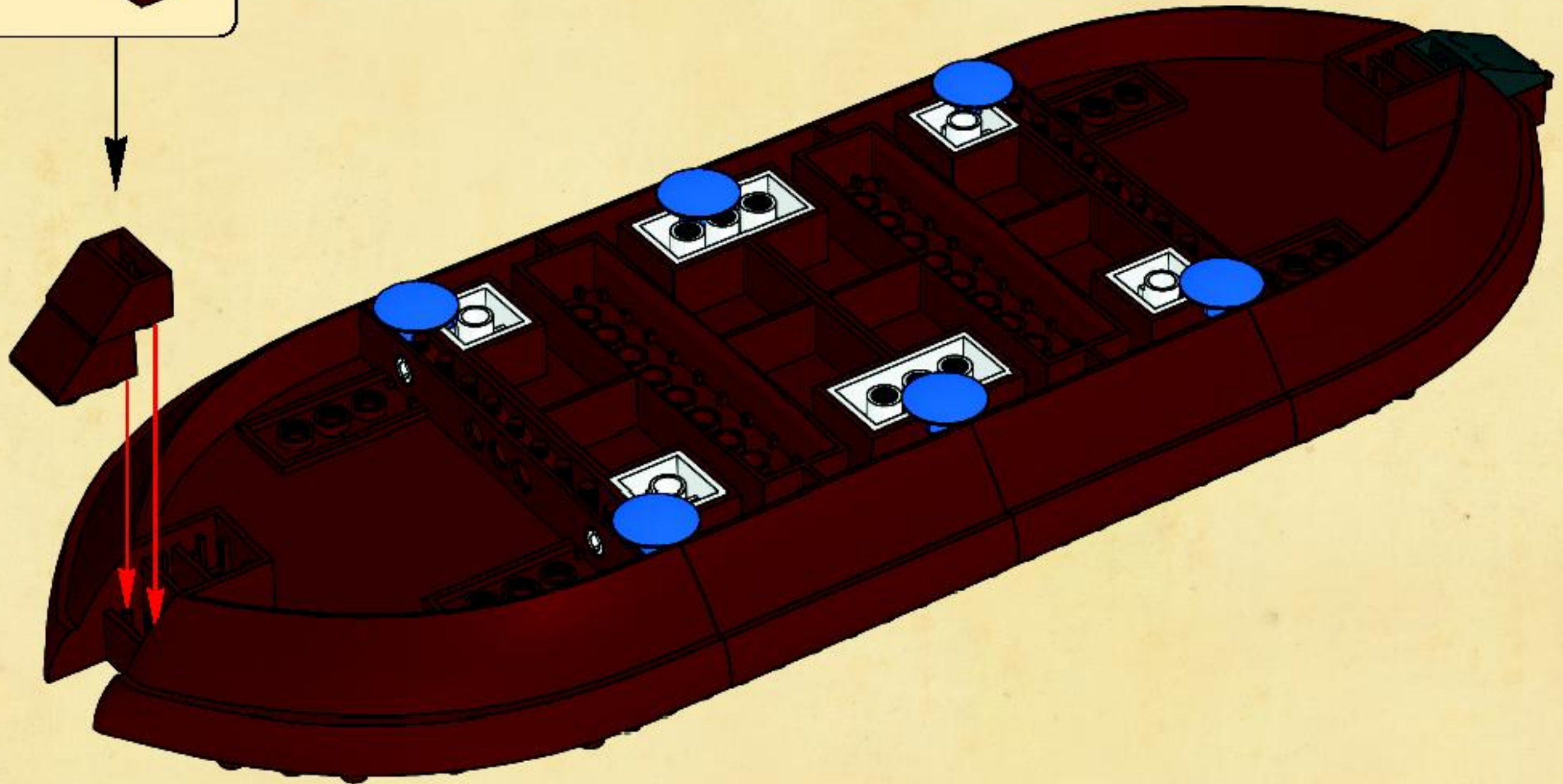
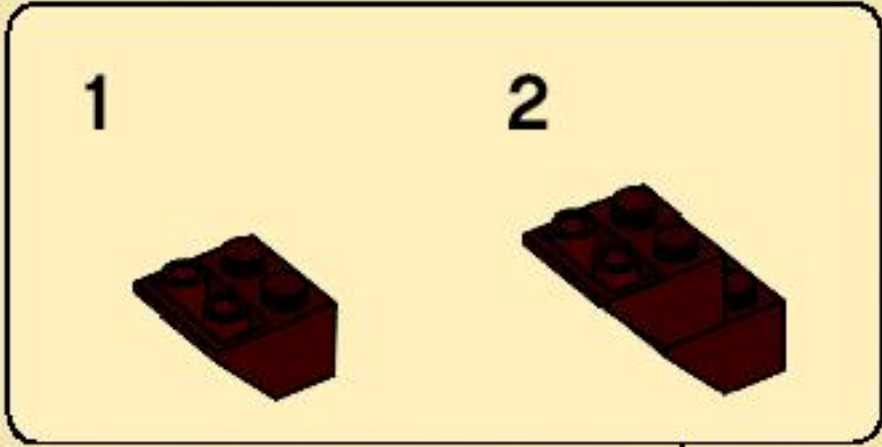



8

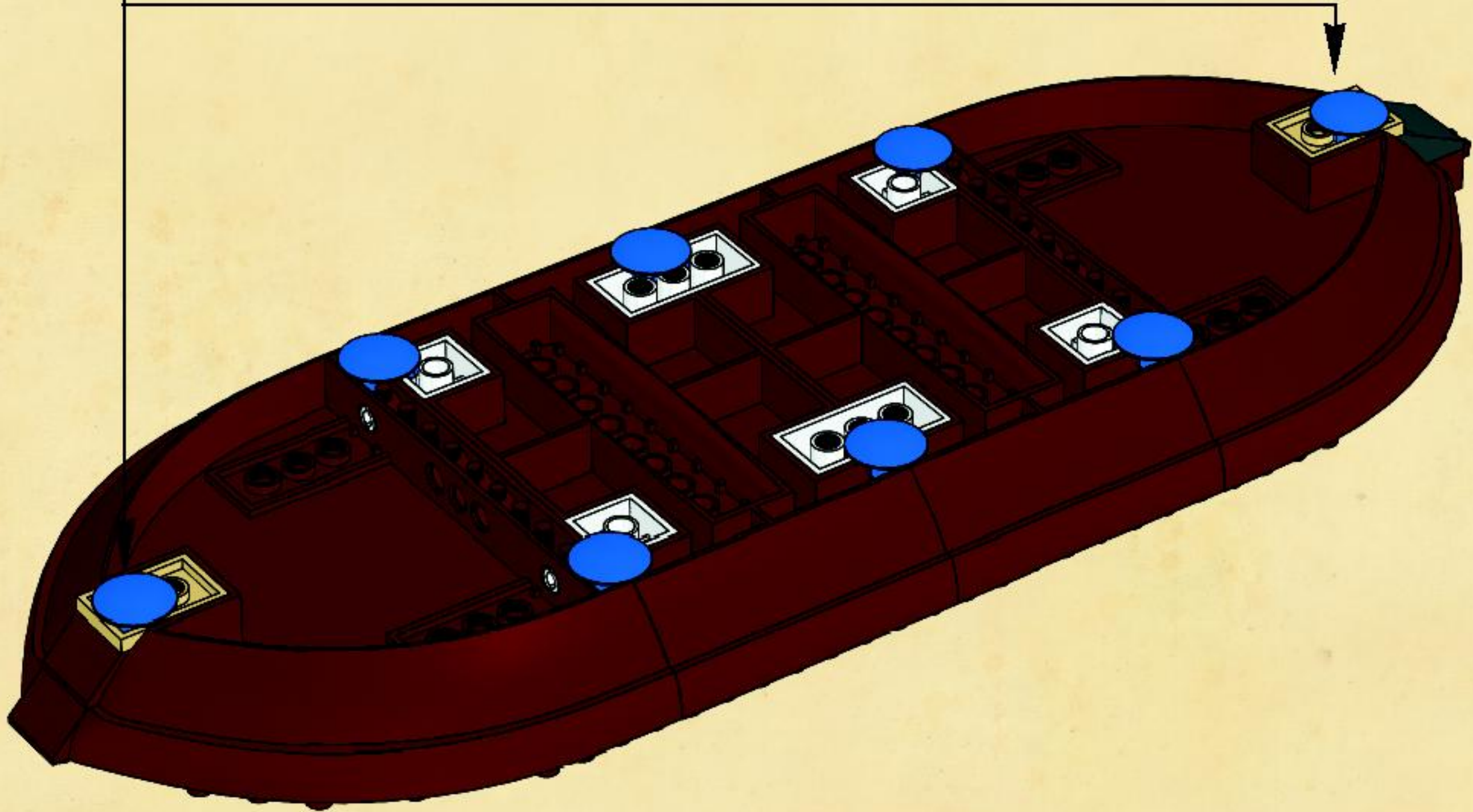
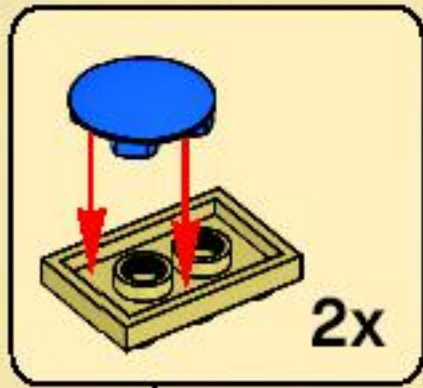

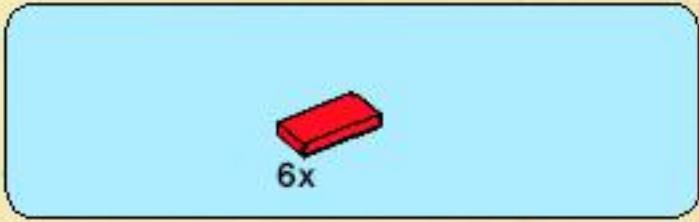

9

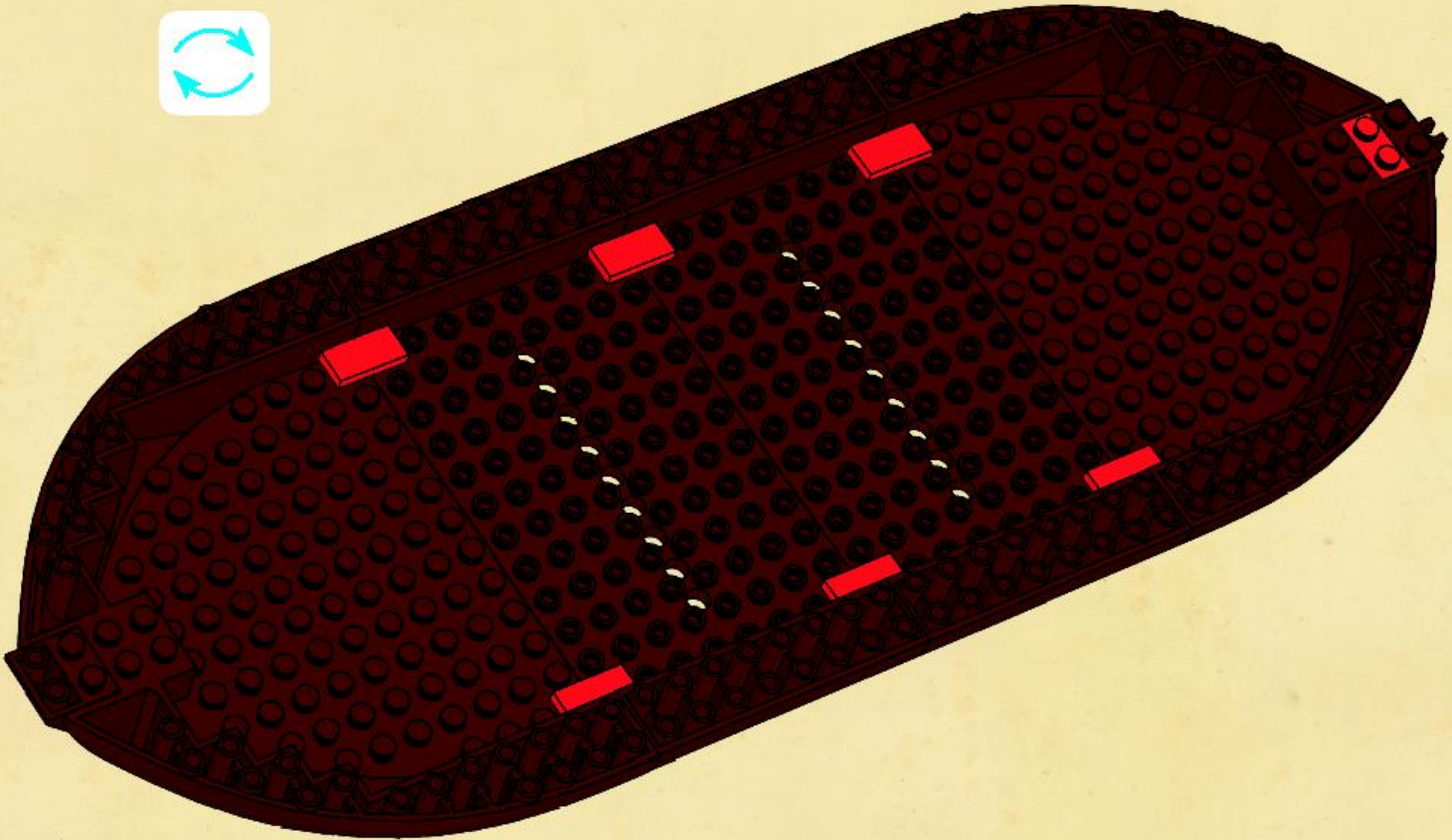

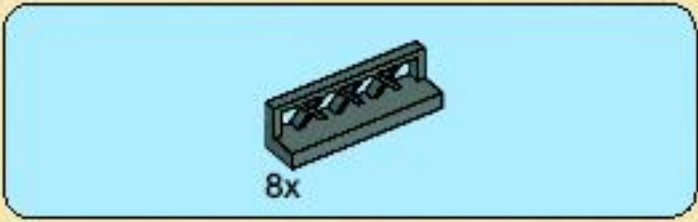

10

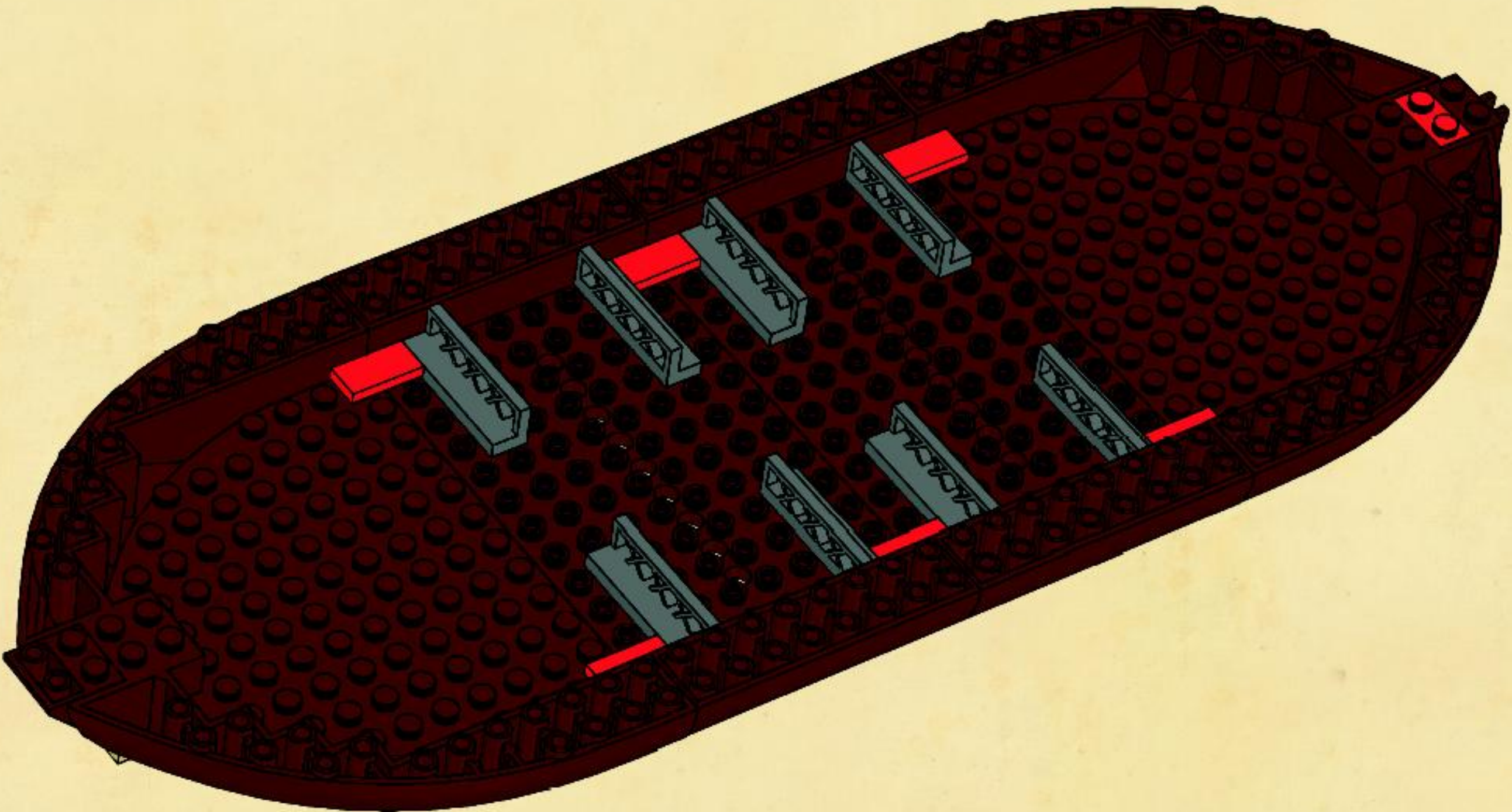



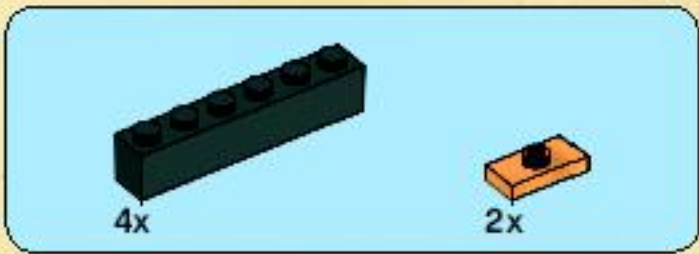

11

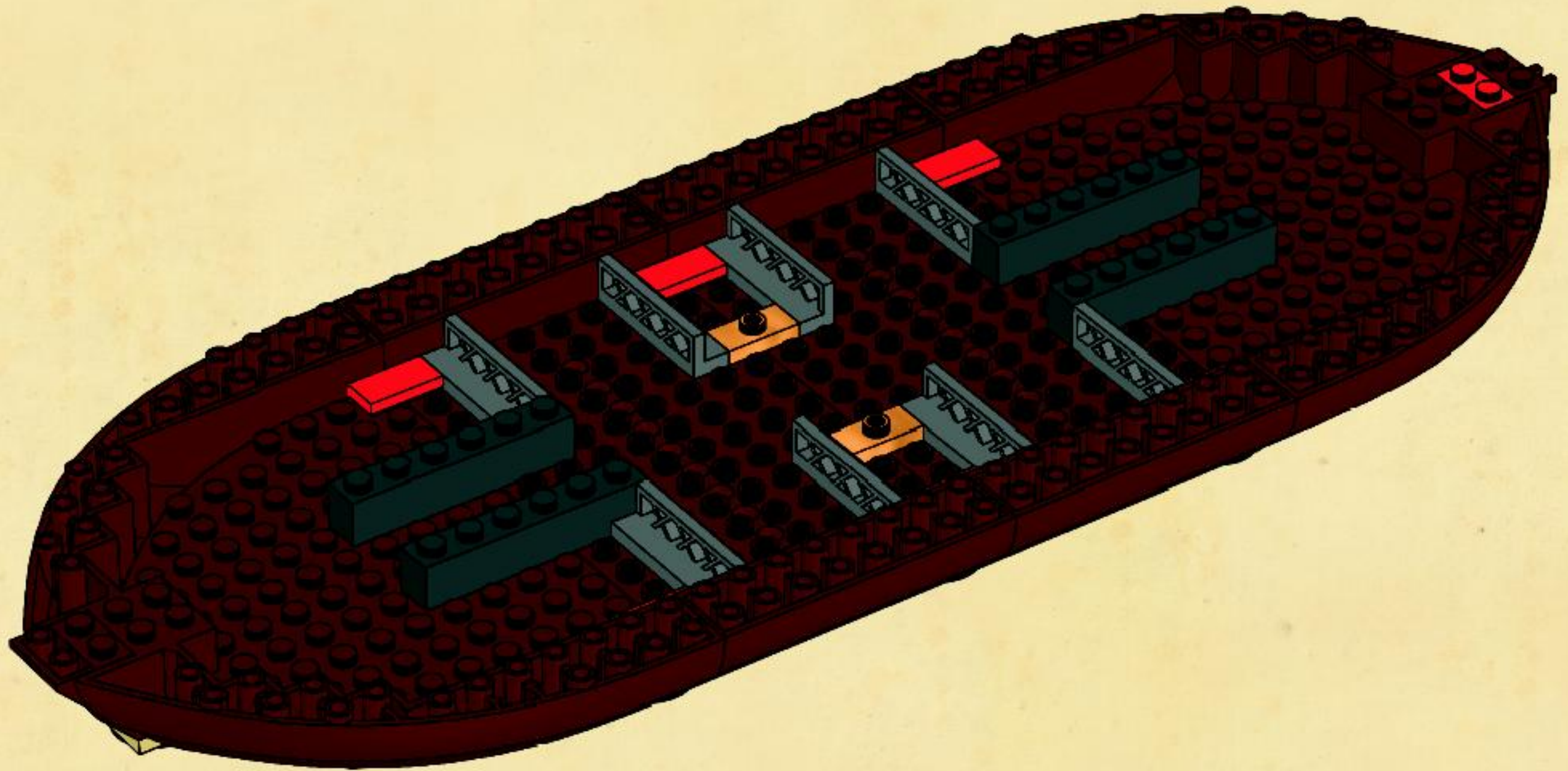

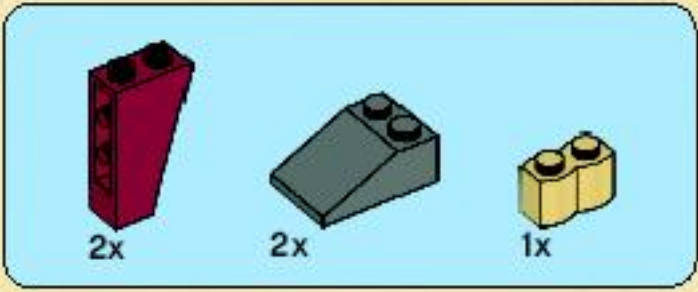

12

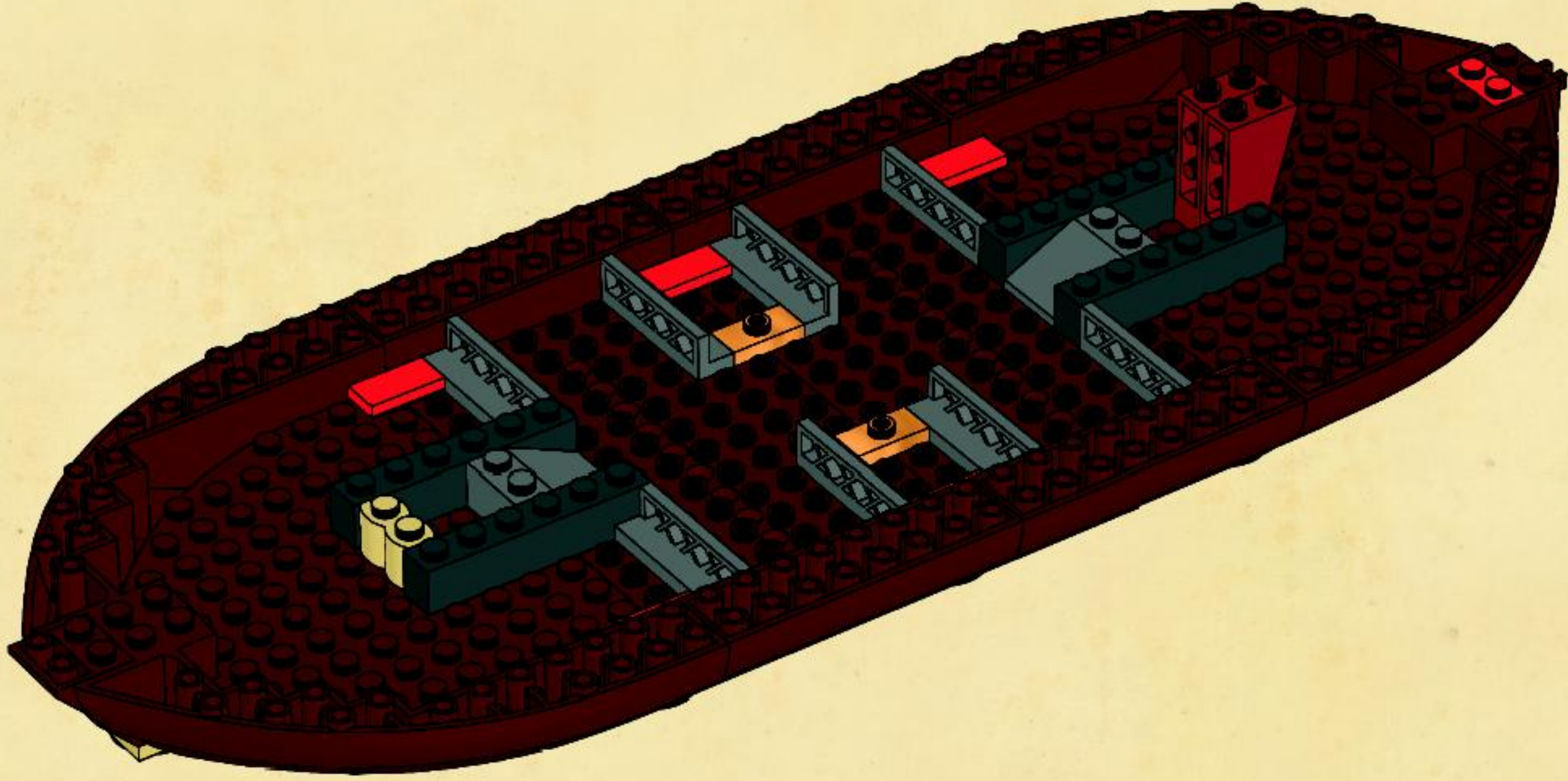

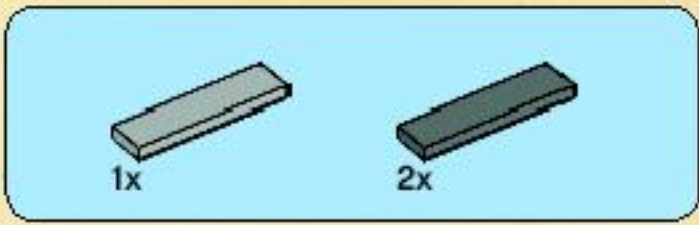

13

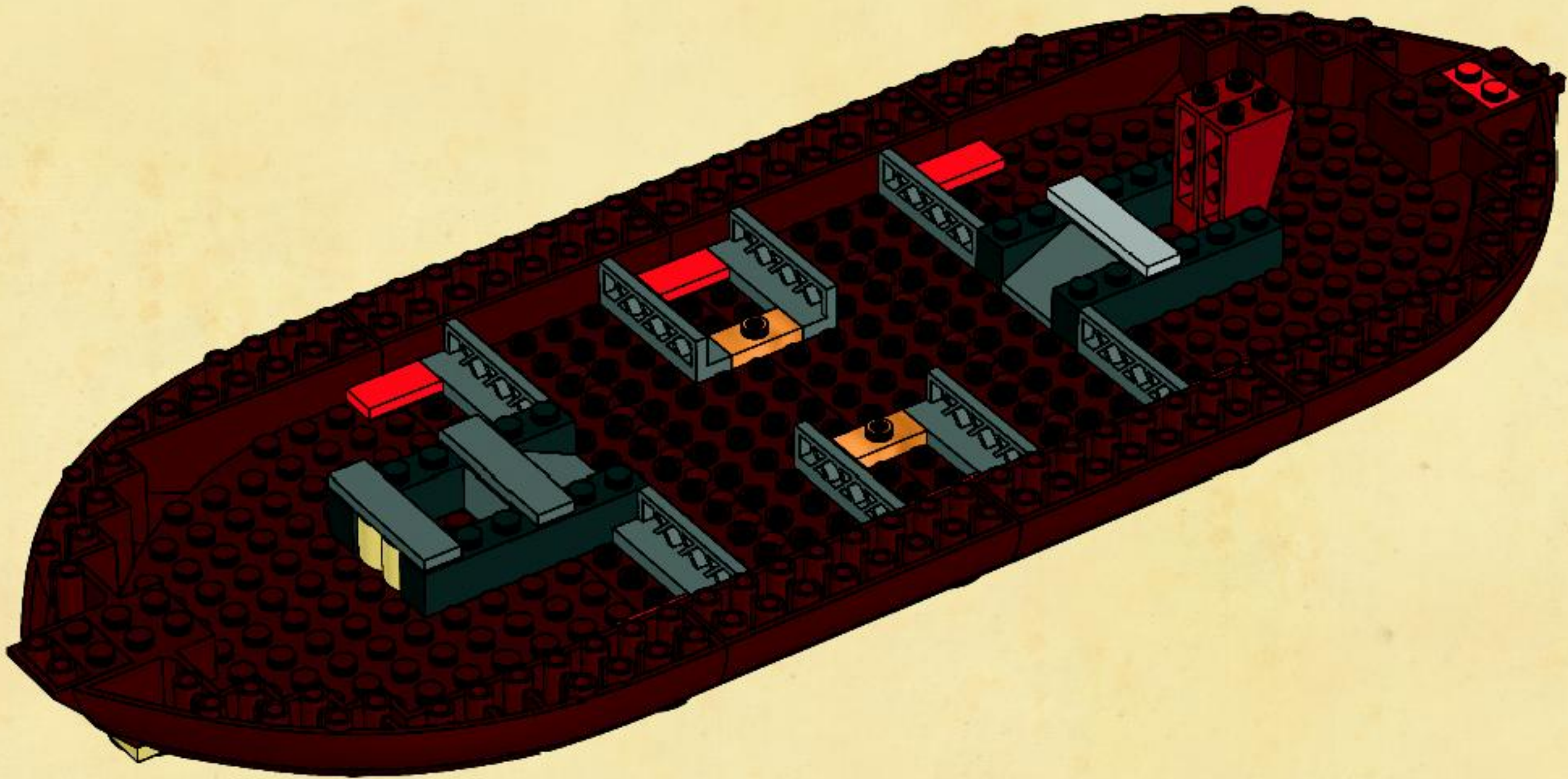

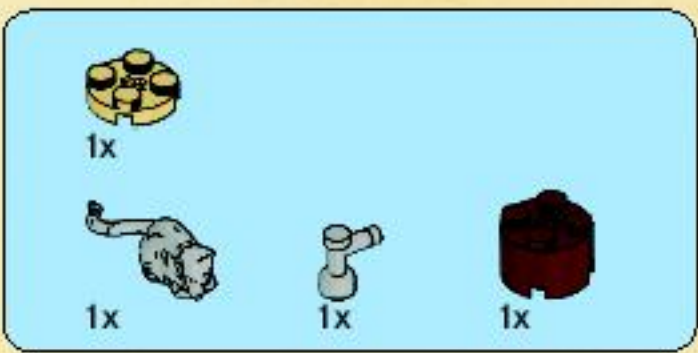

14

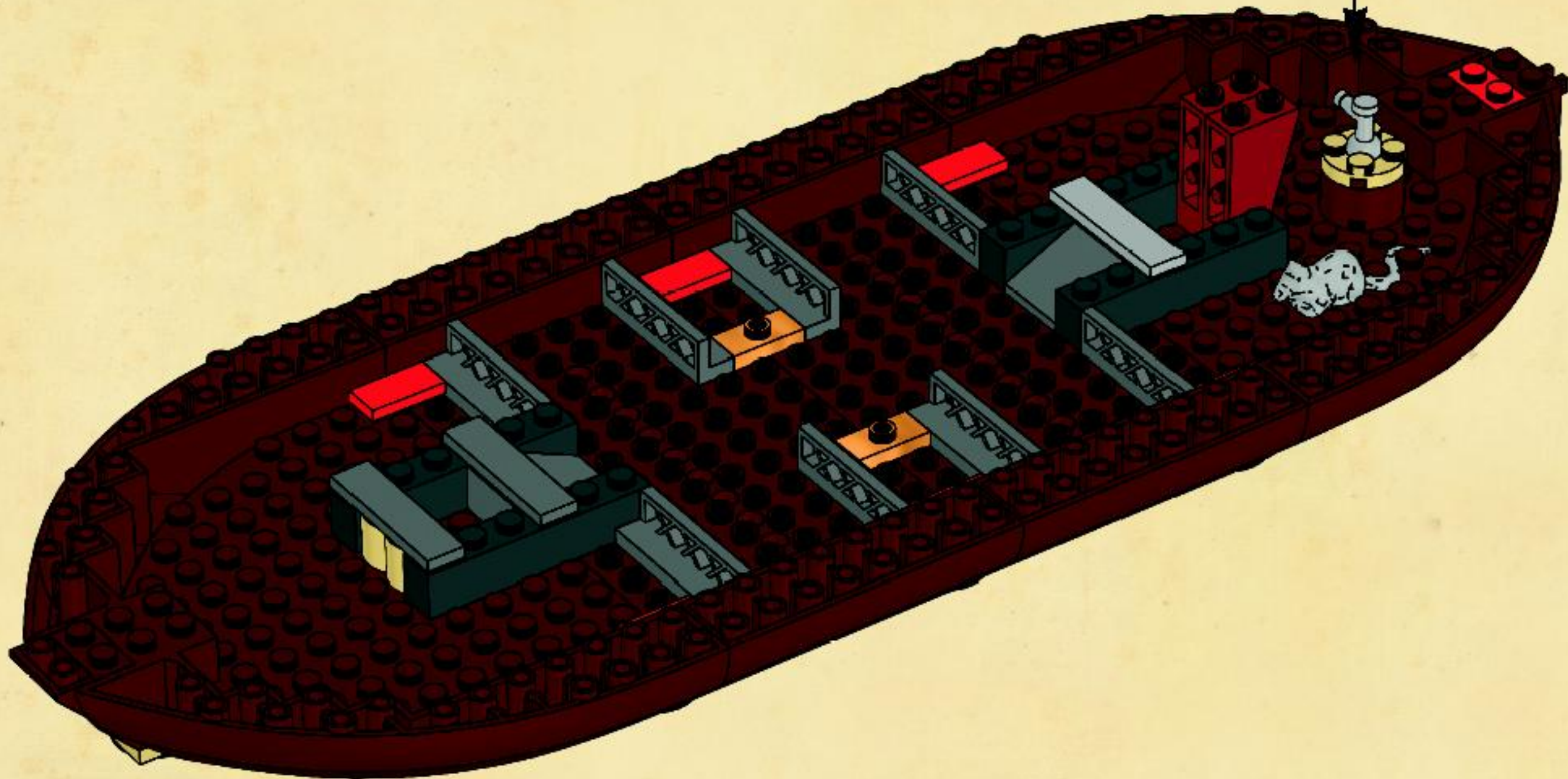
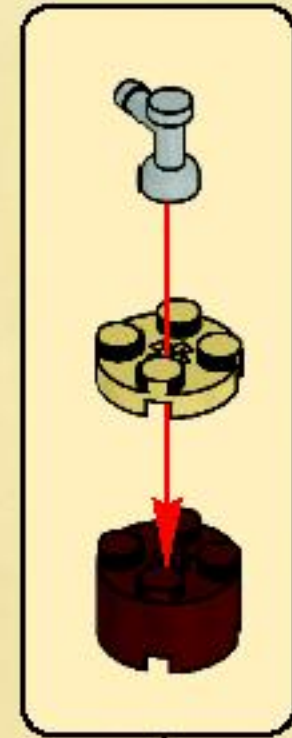

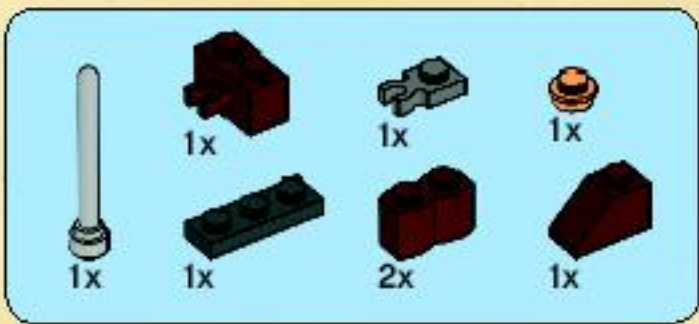

15

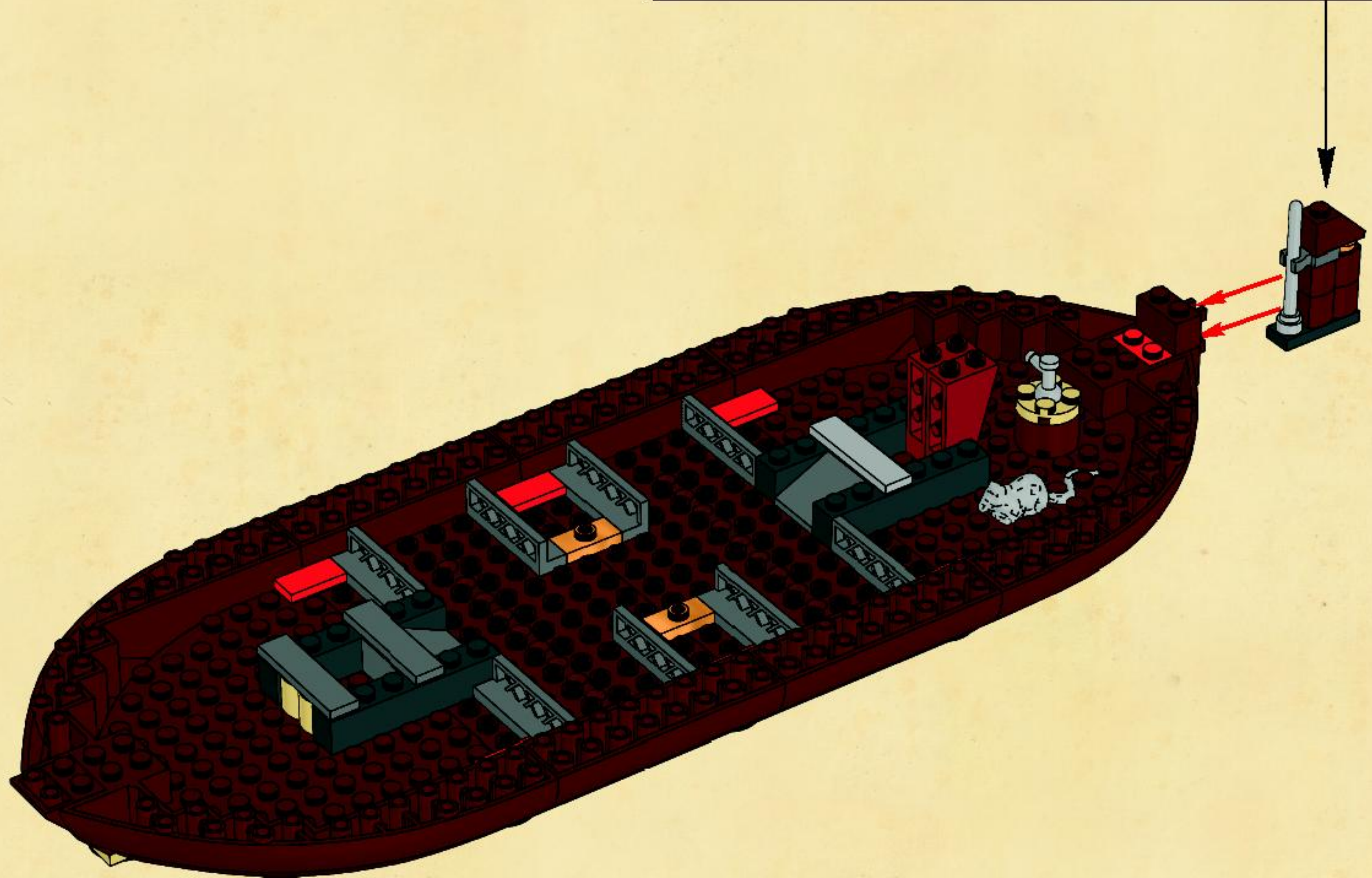
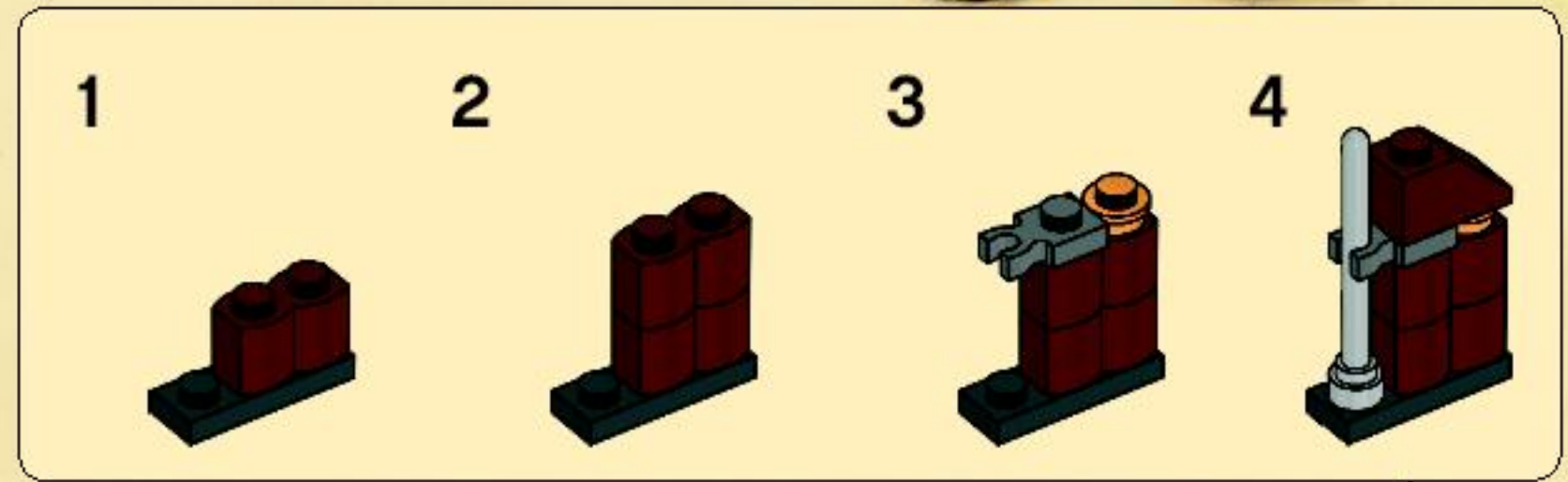



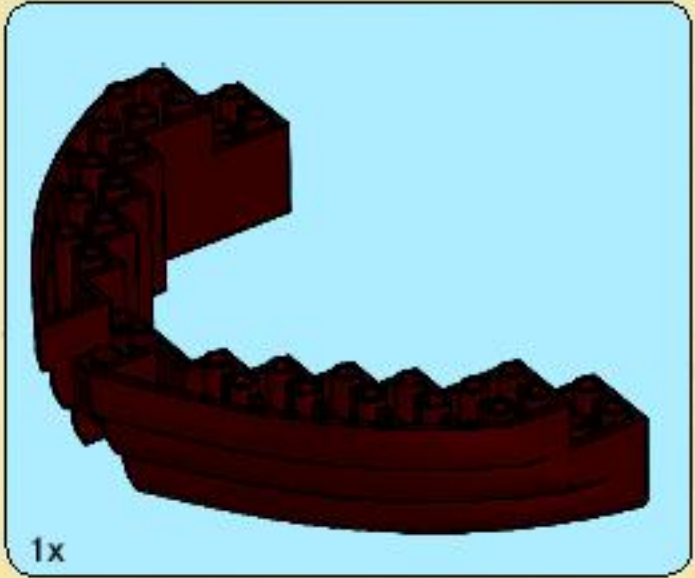
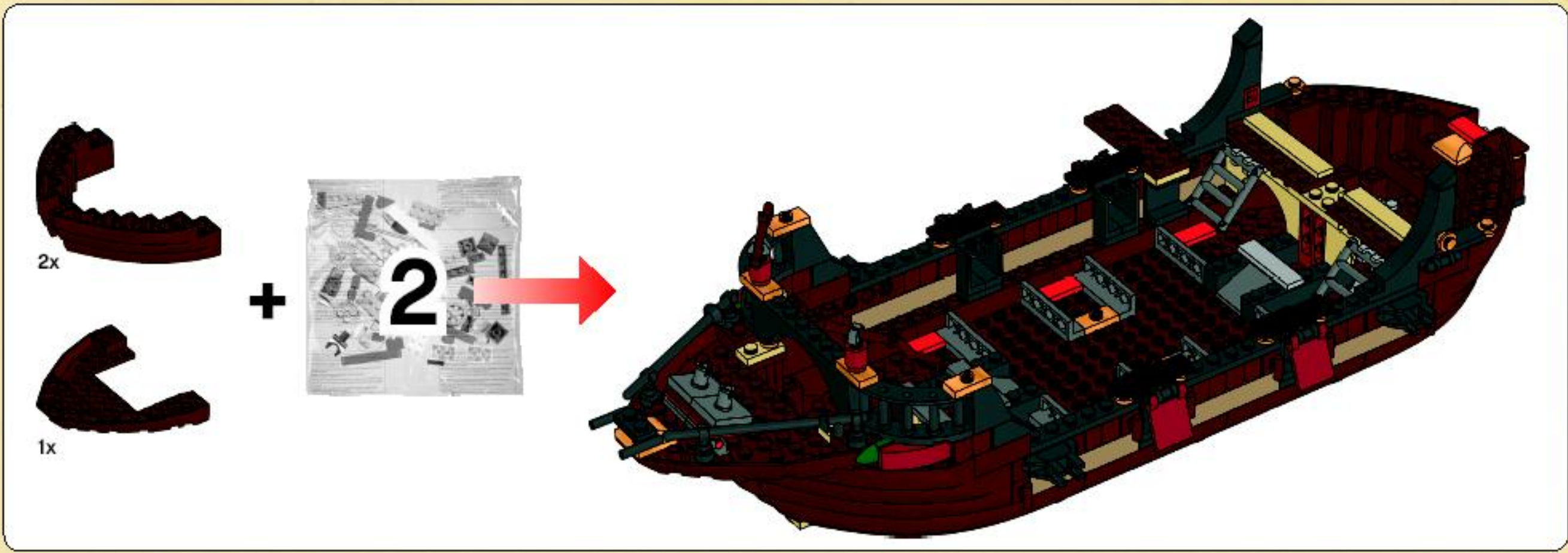

16

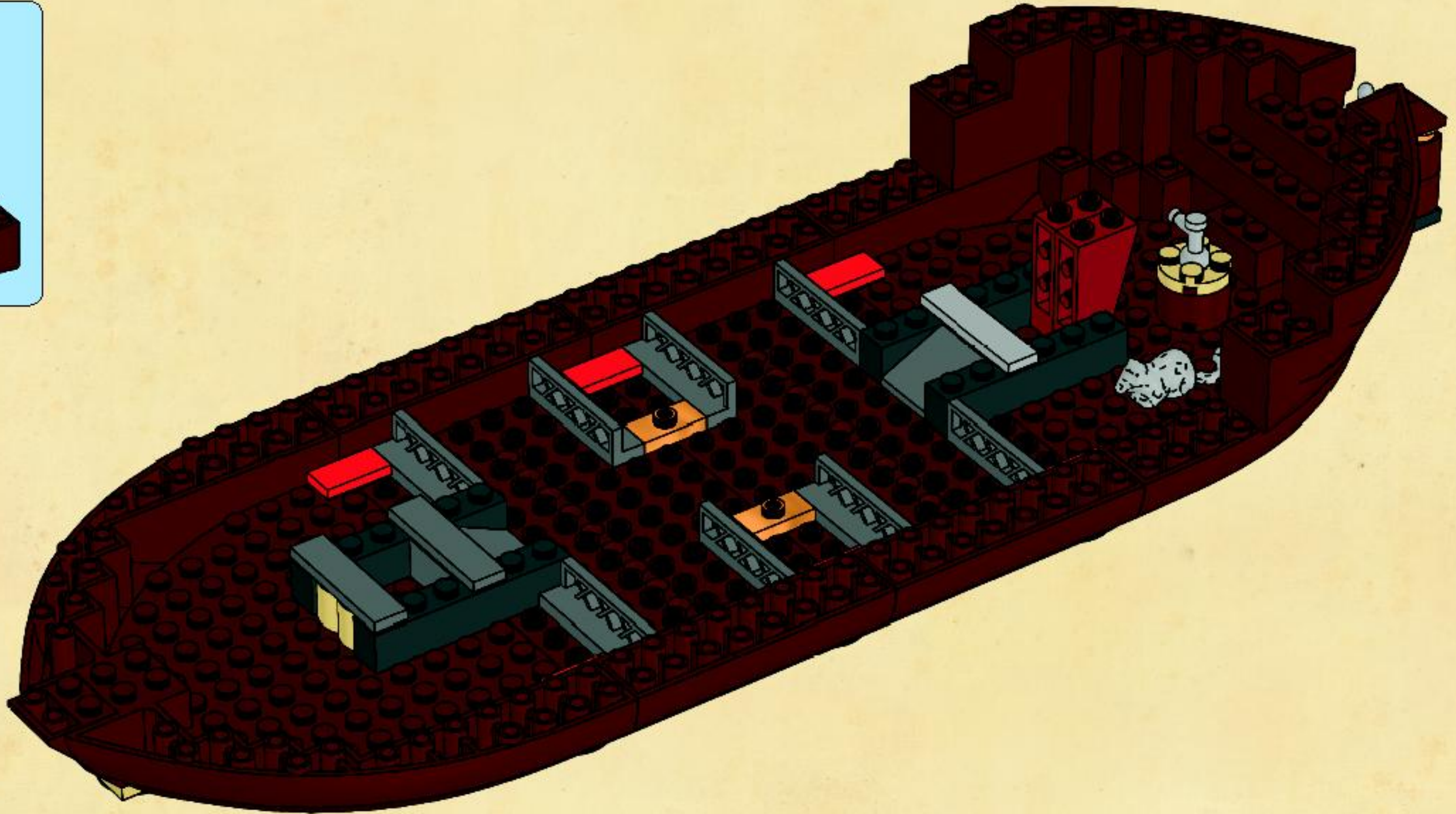

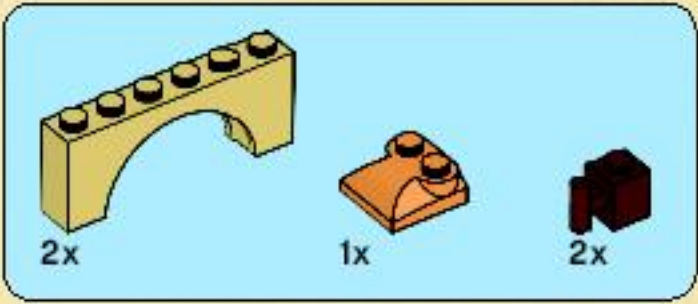

17

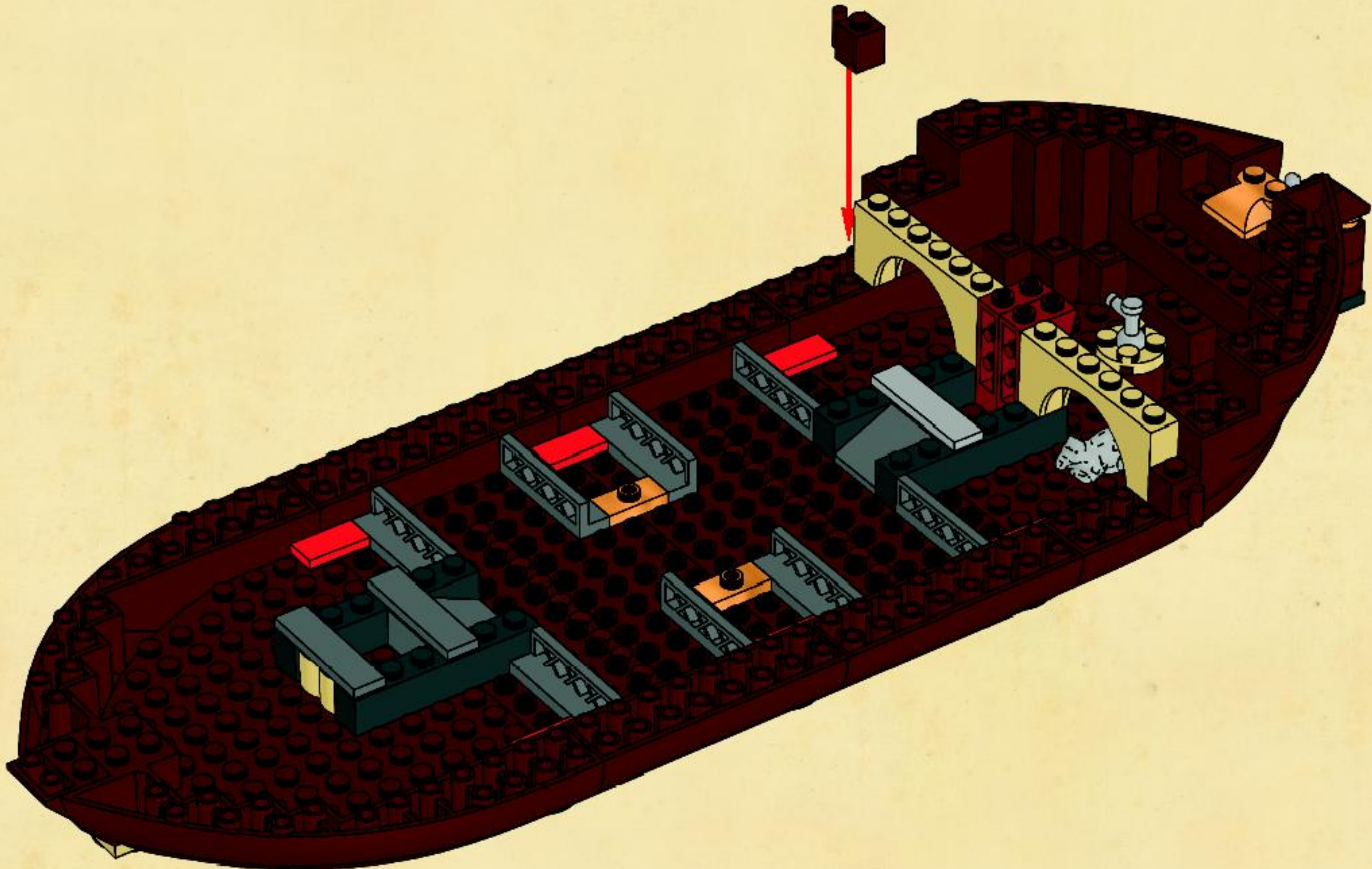



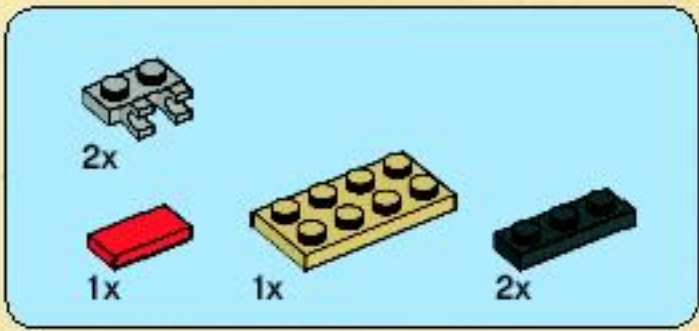

18

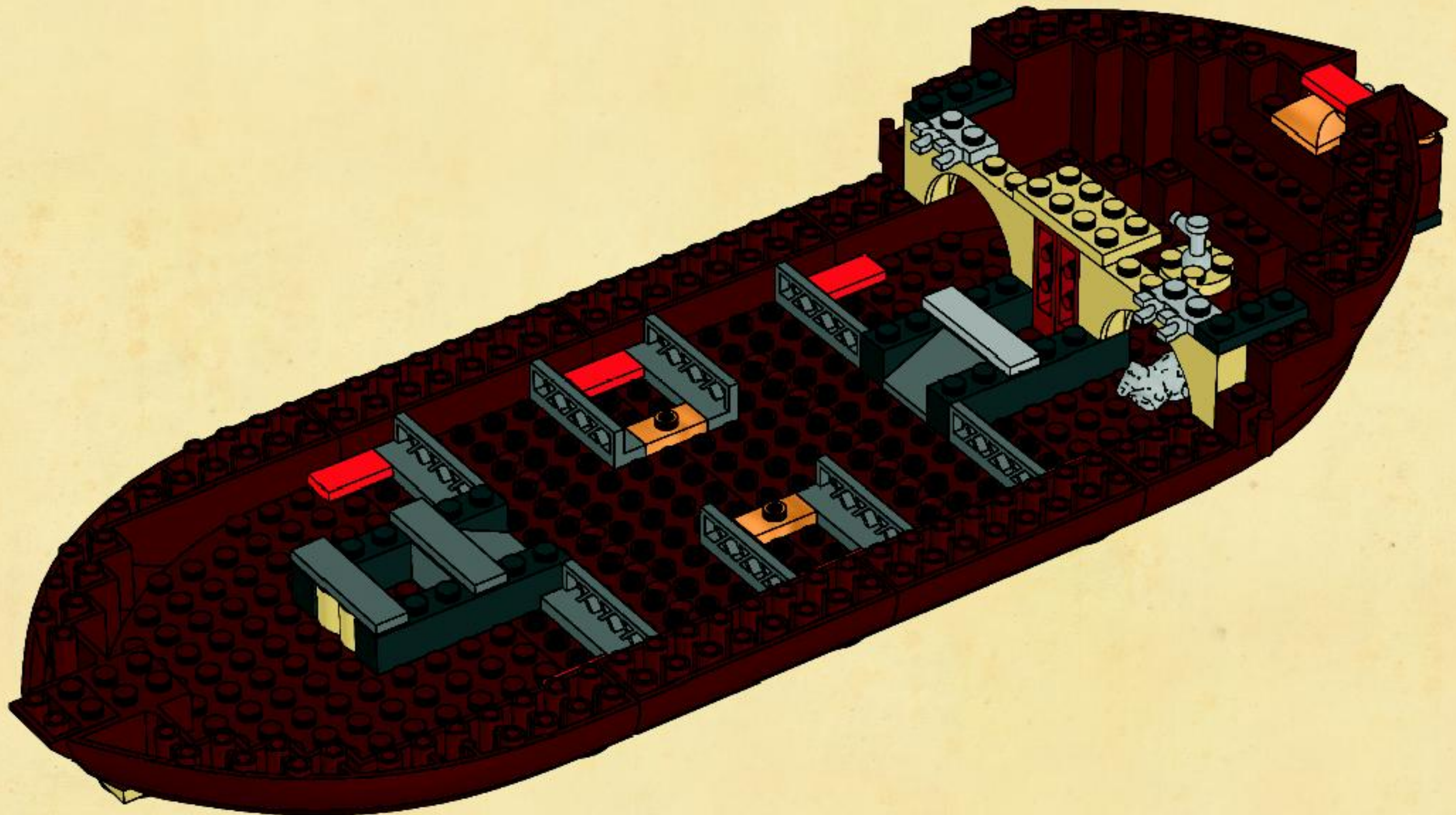

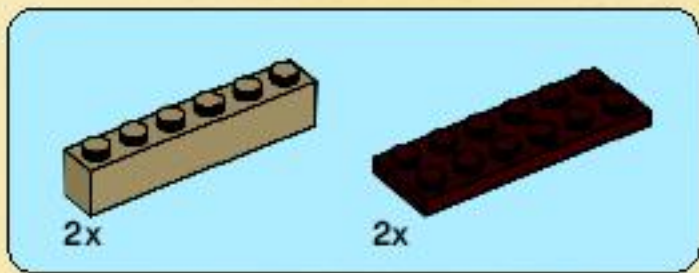

19

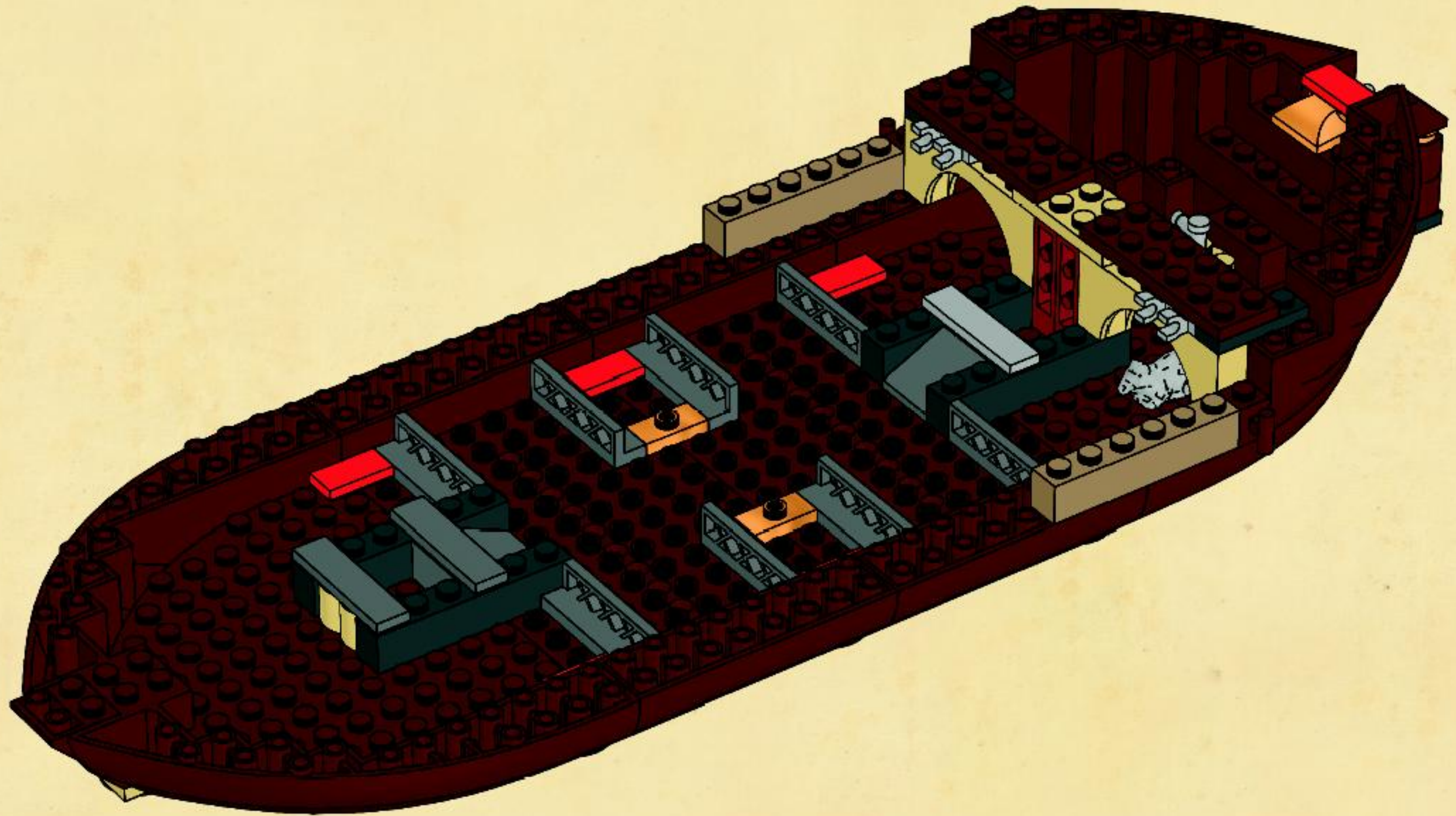

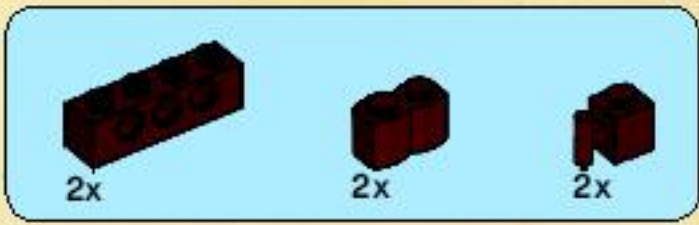

20

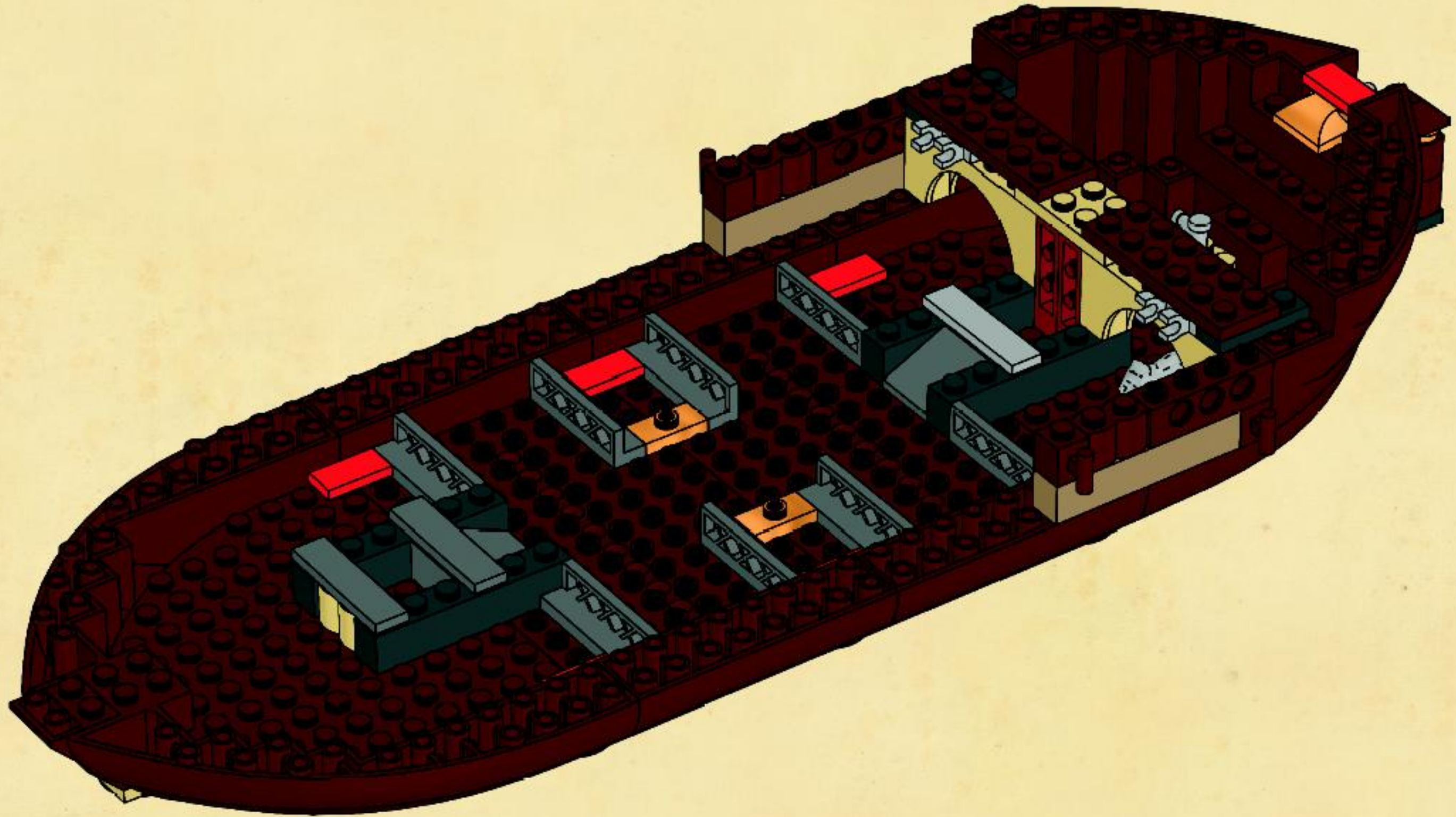

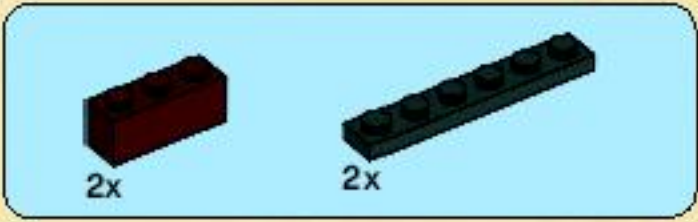

21

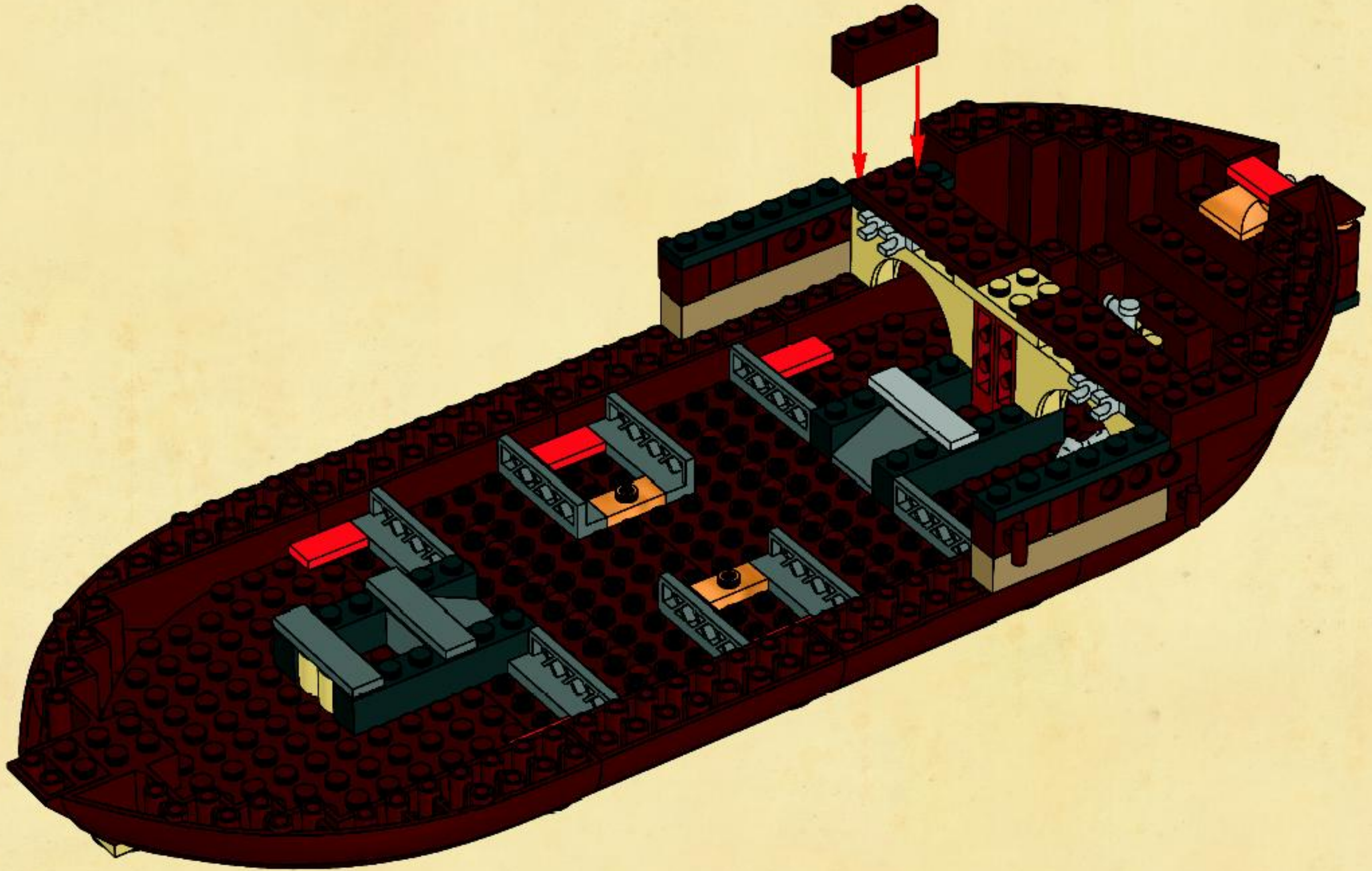

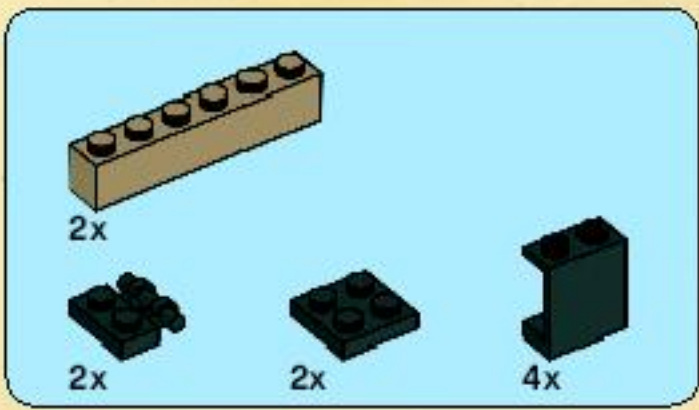

22

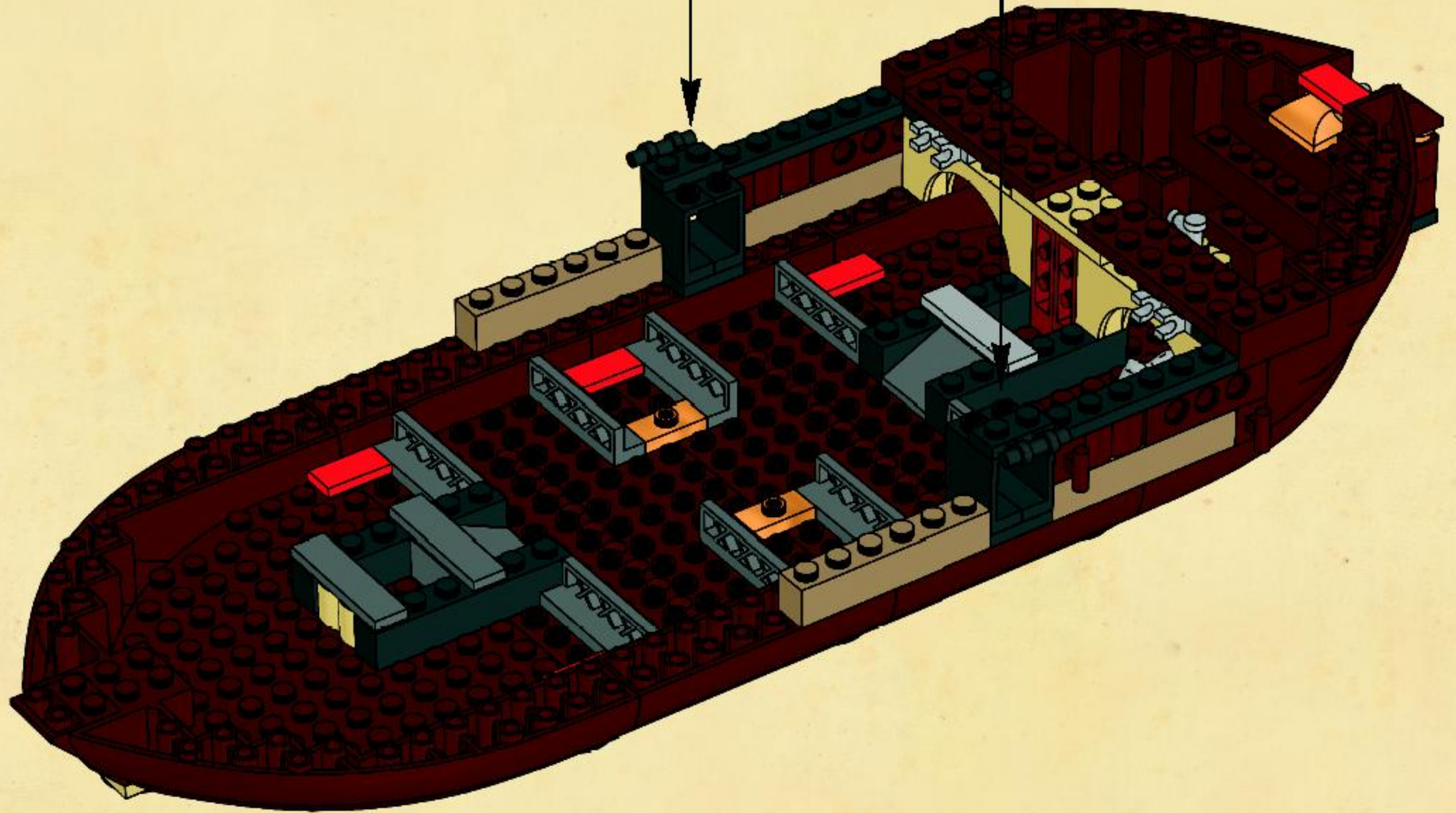
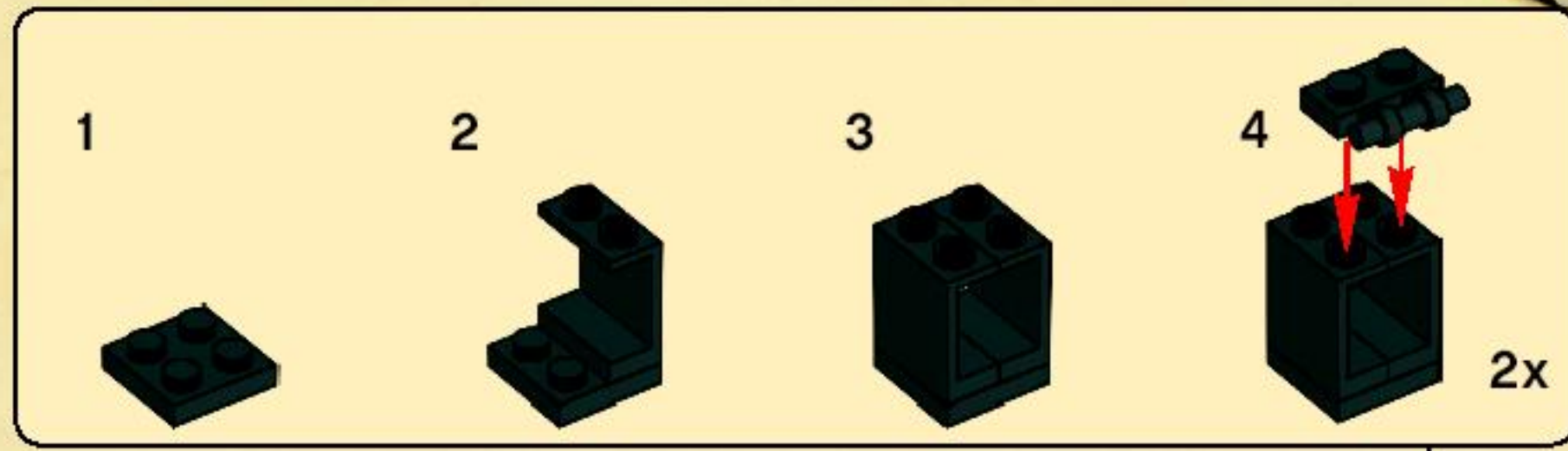

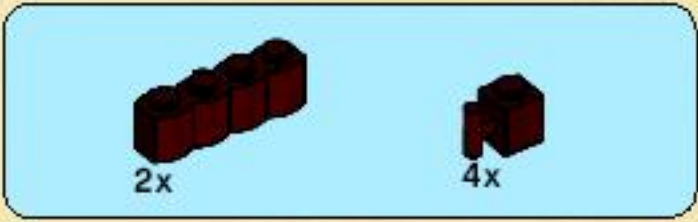

23

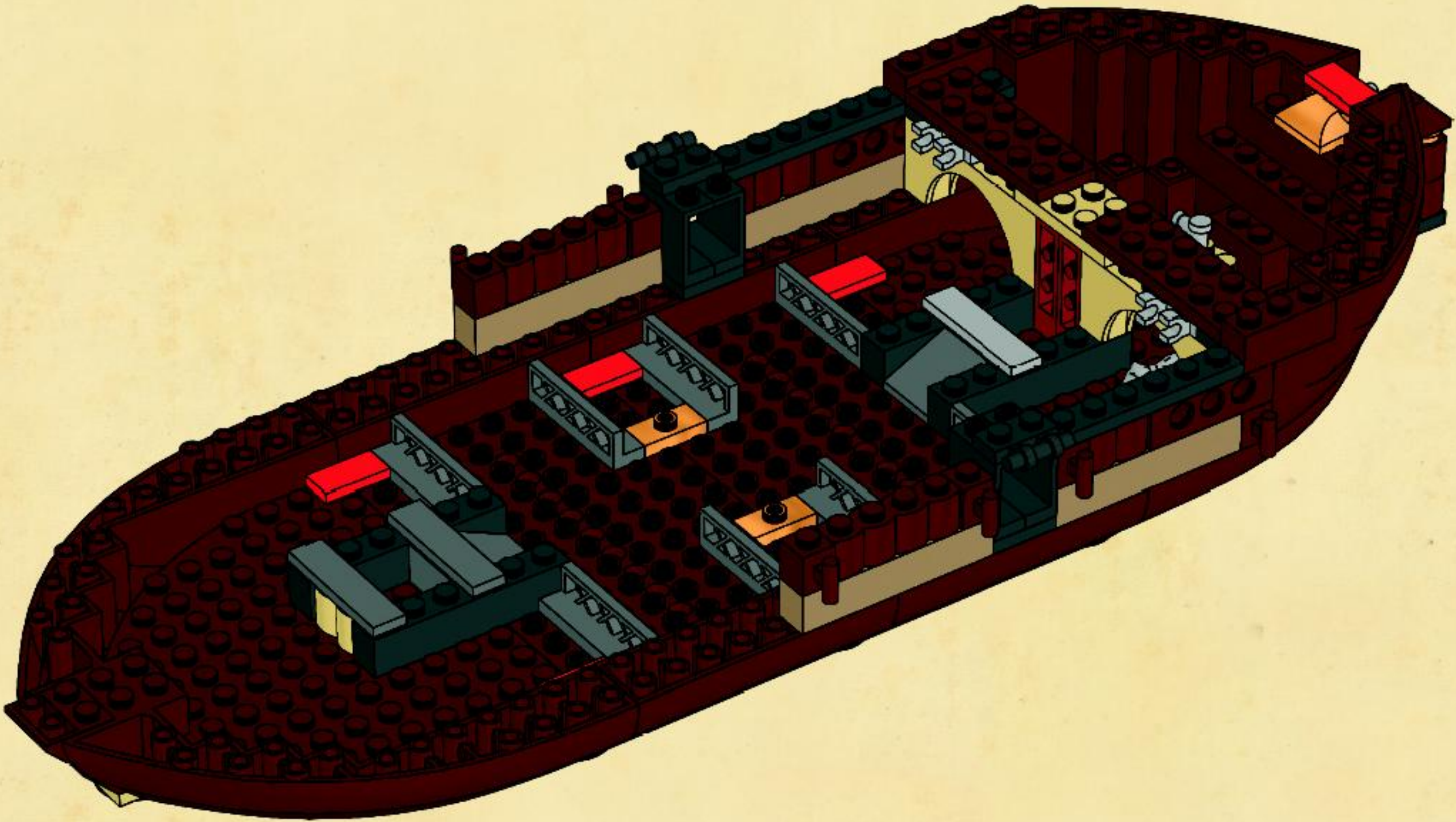

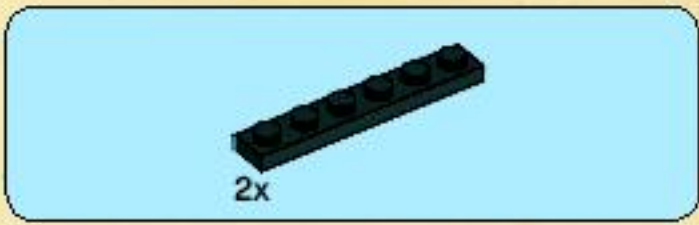

24

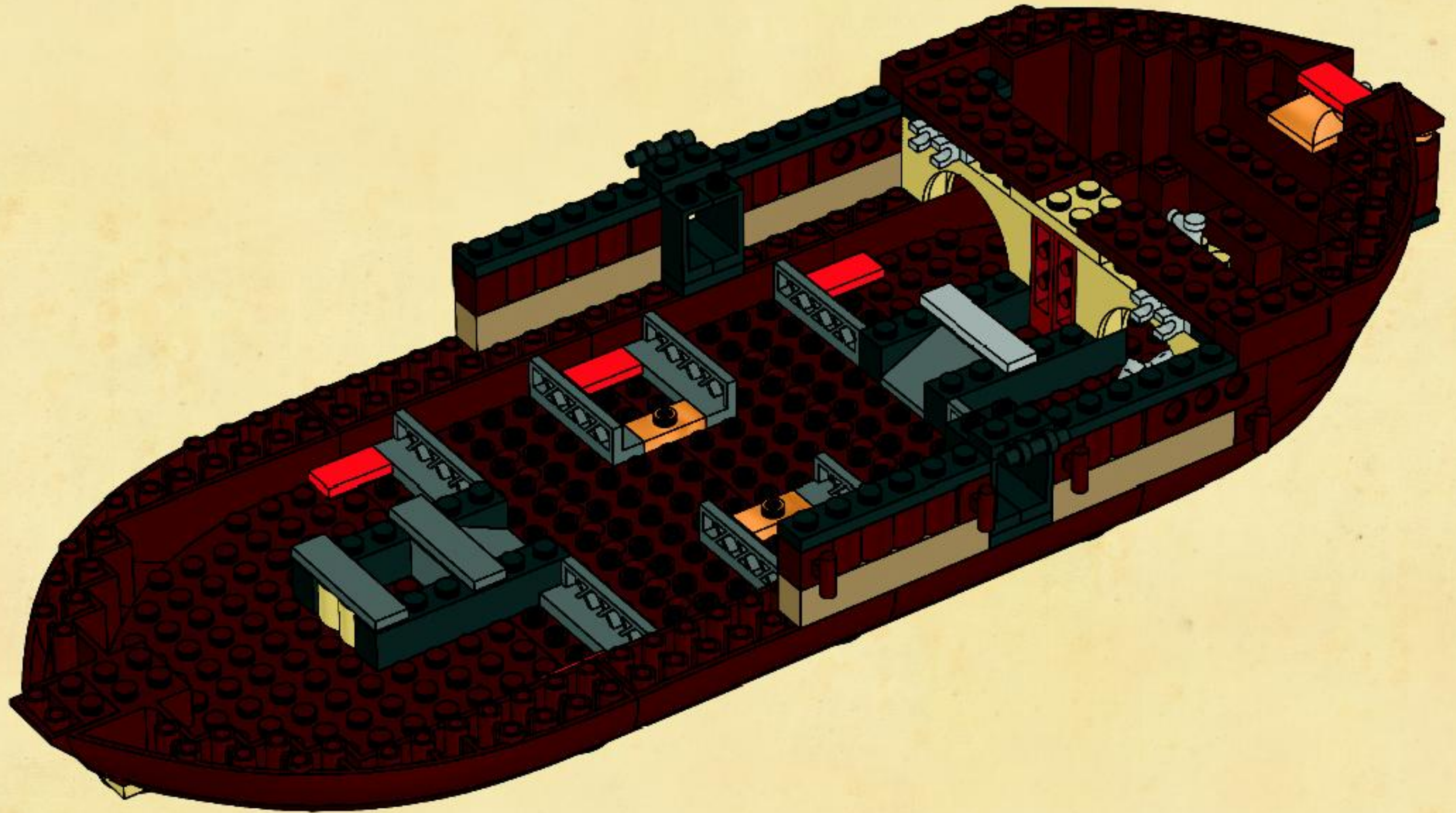

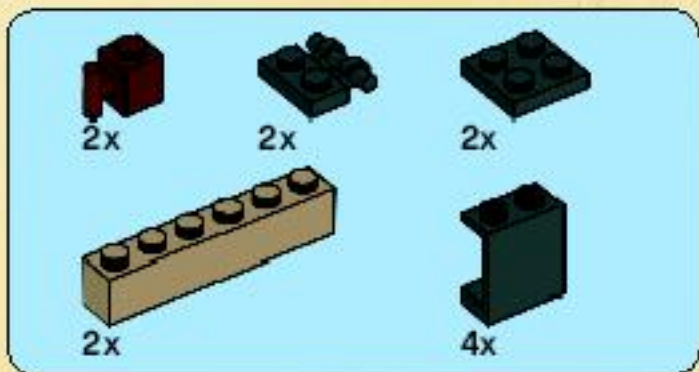

25

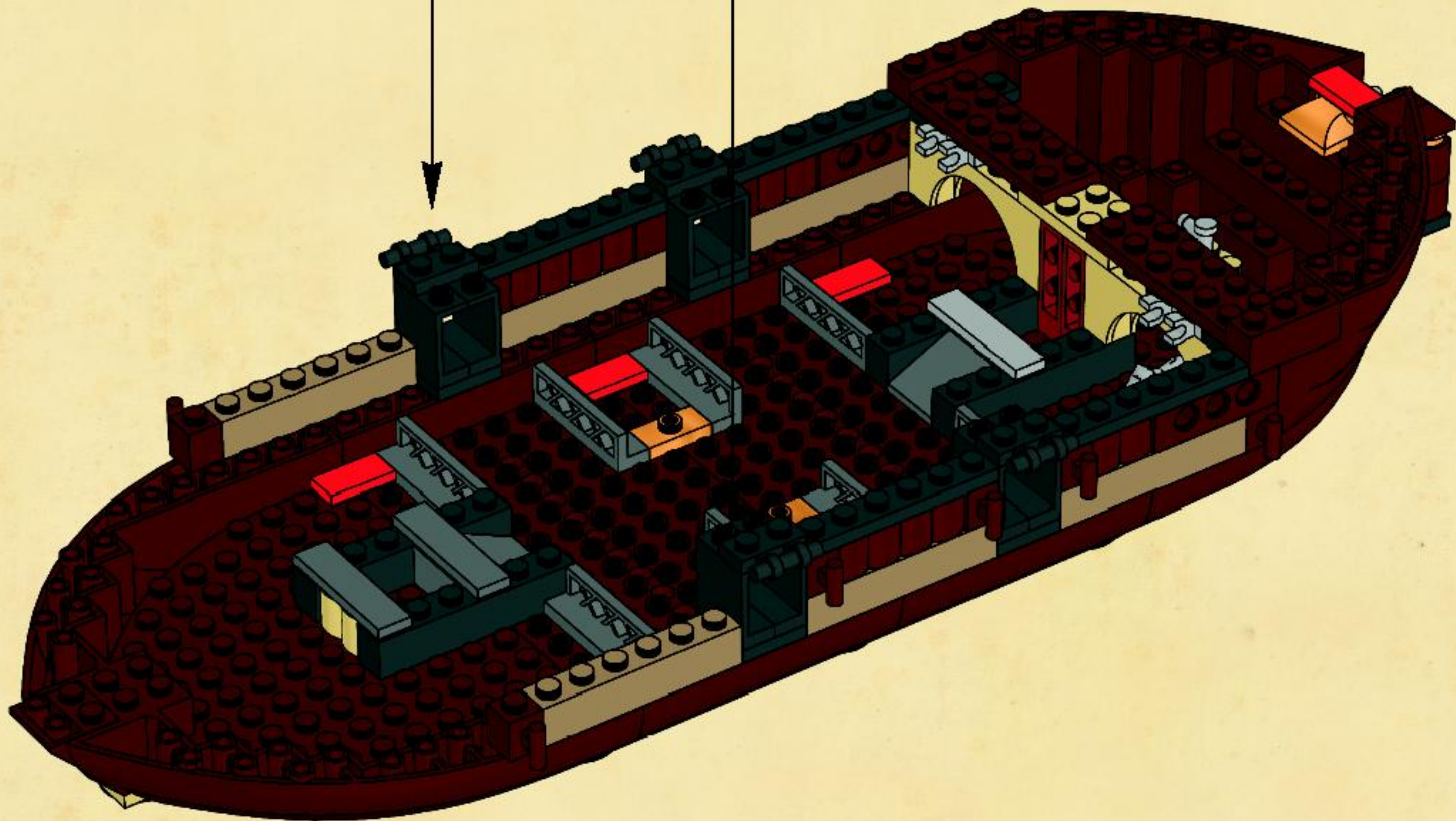
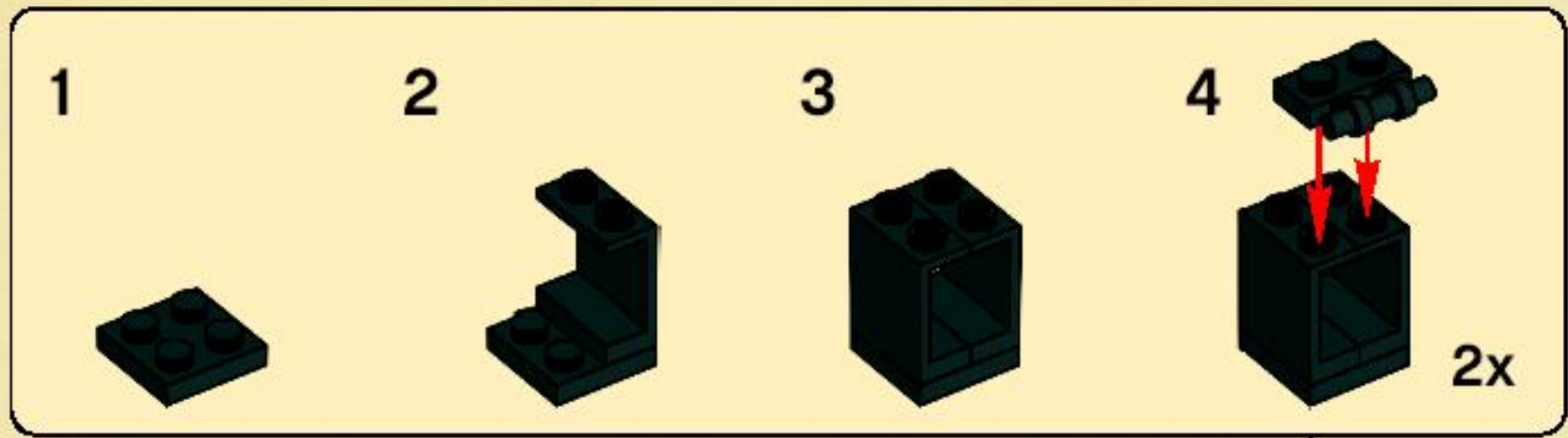





26

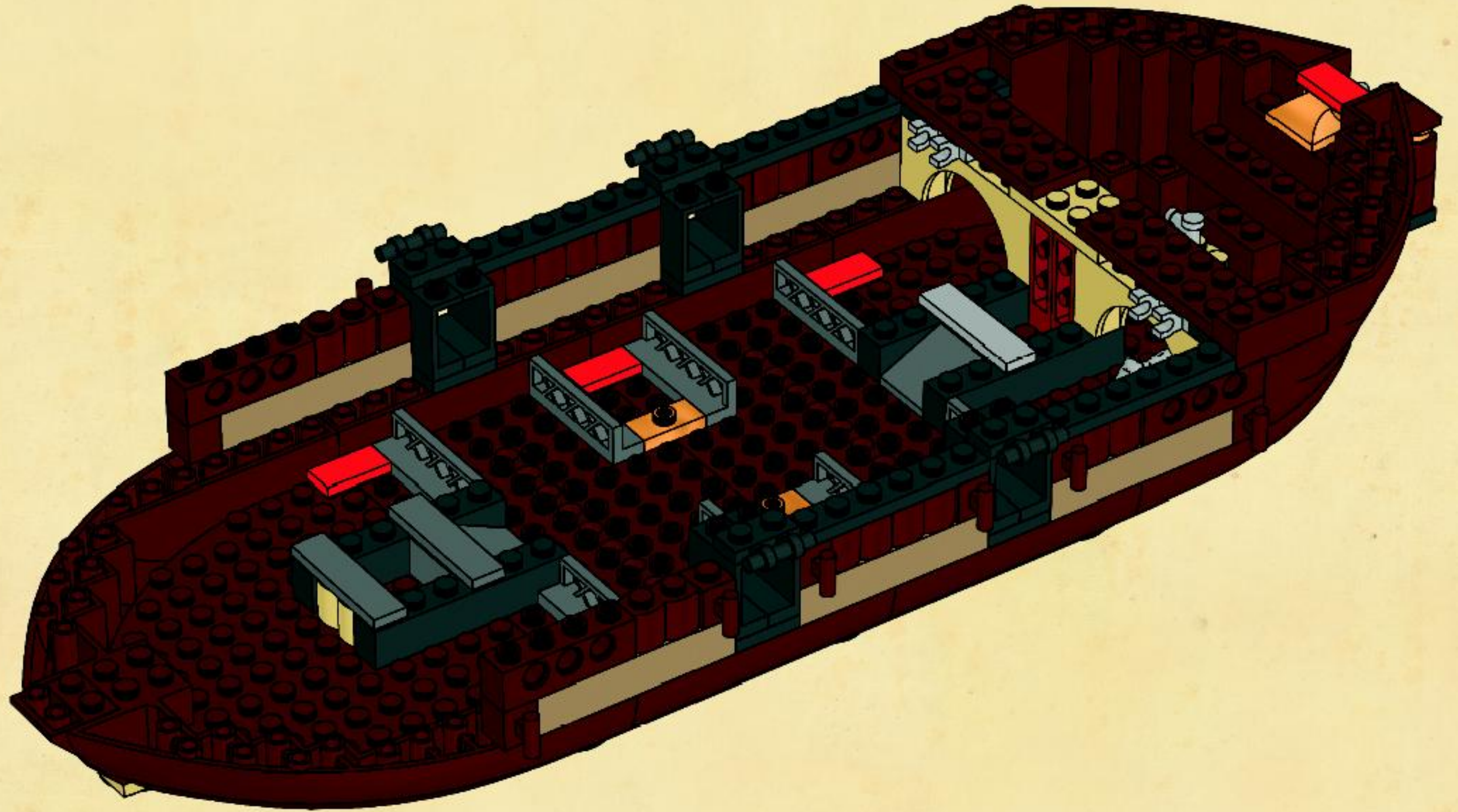

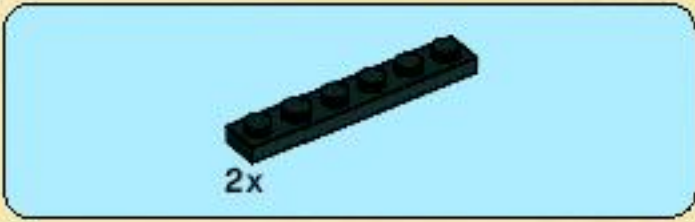

27

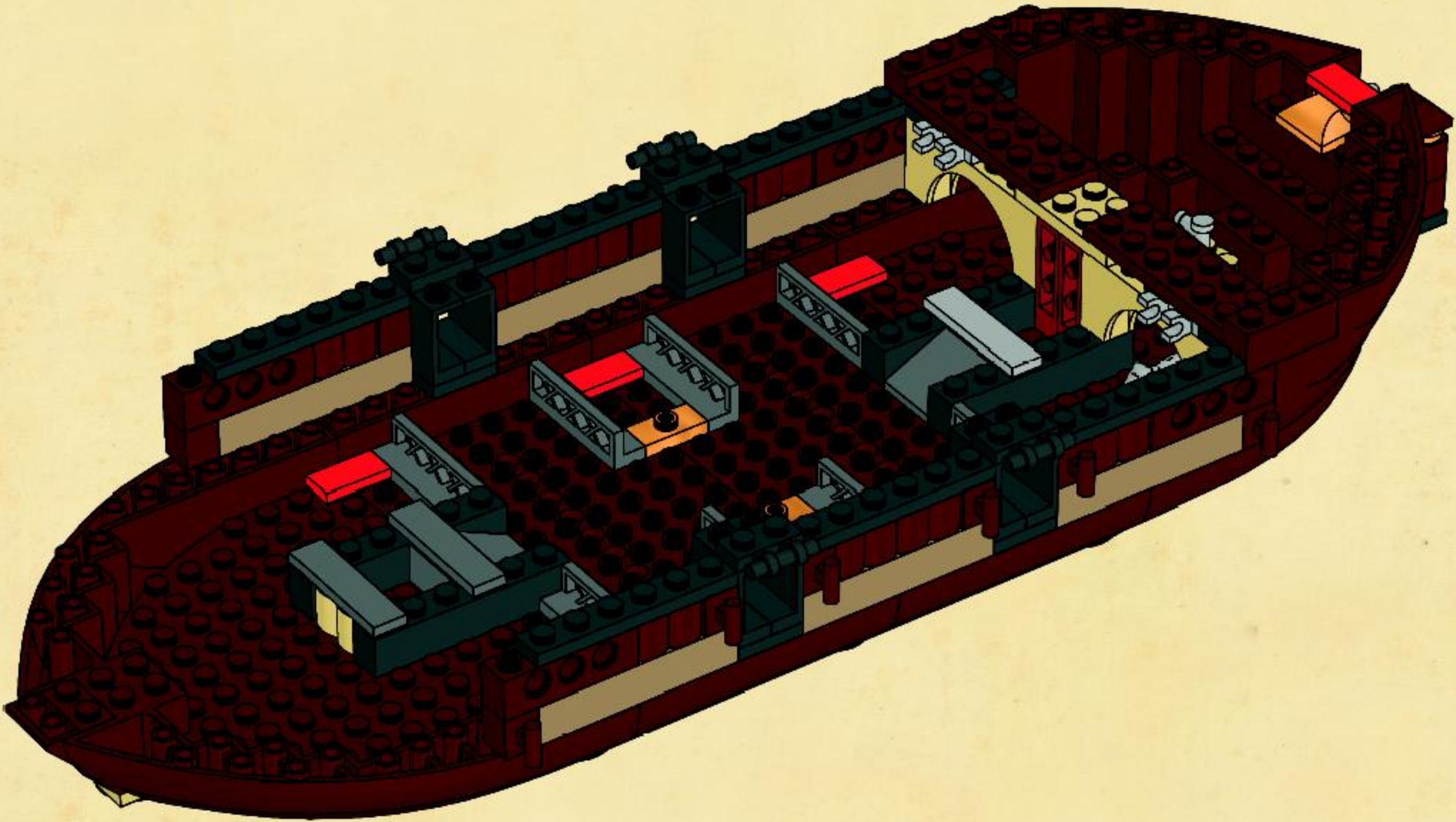

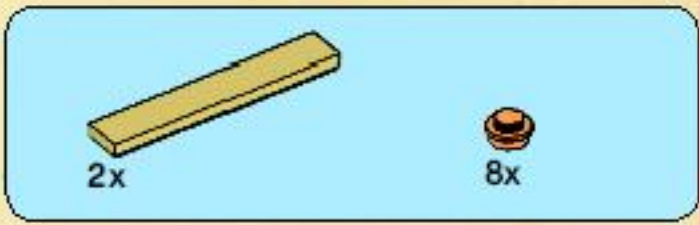

28

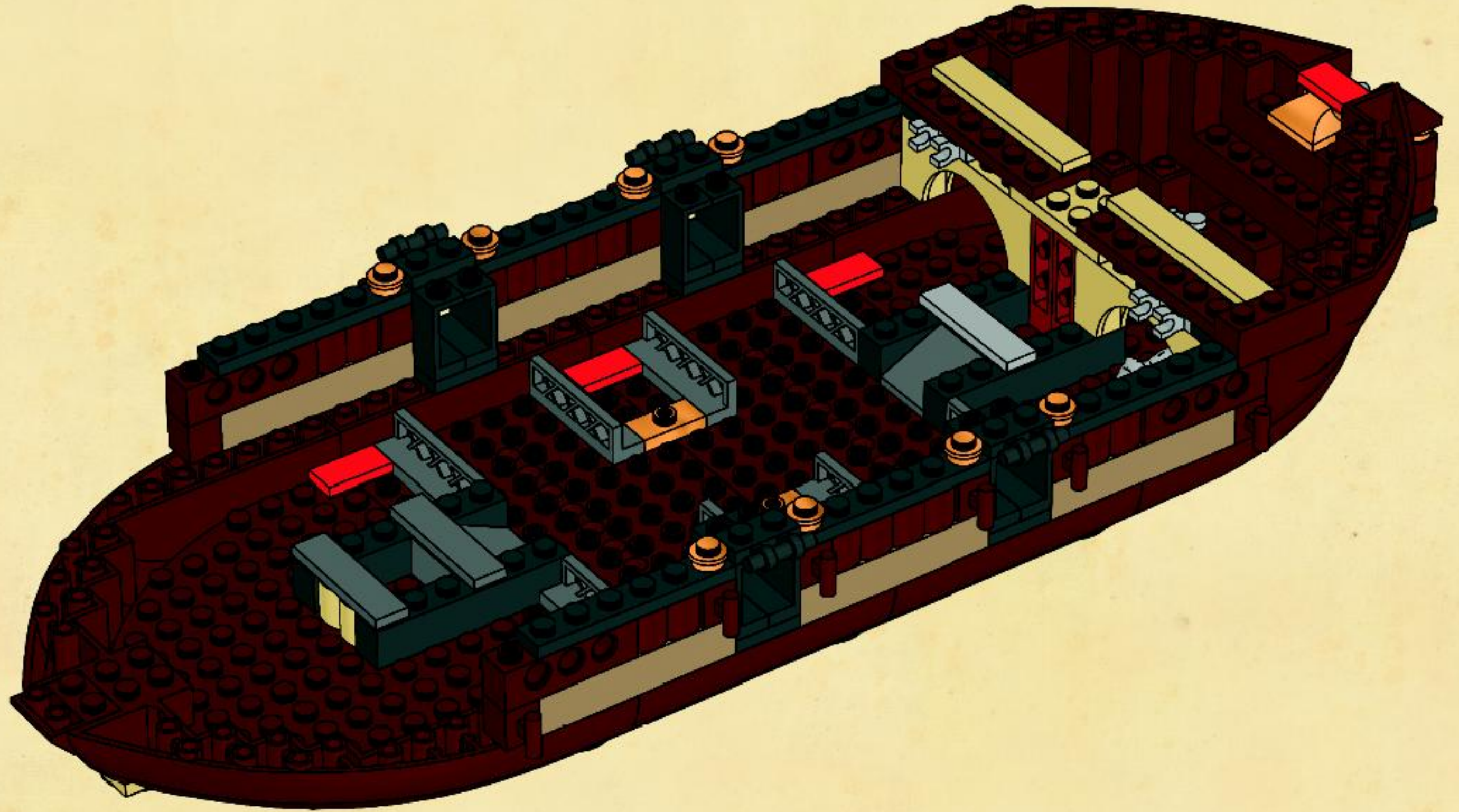

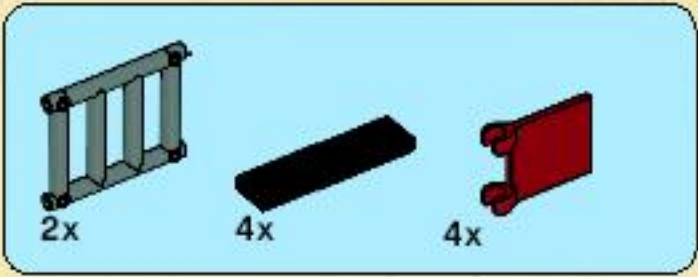

29

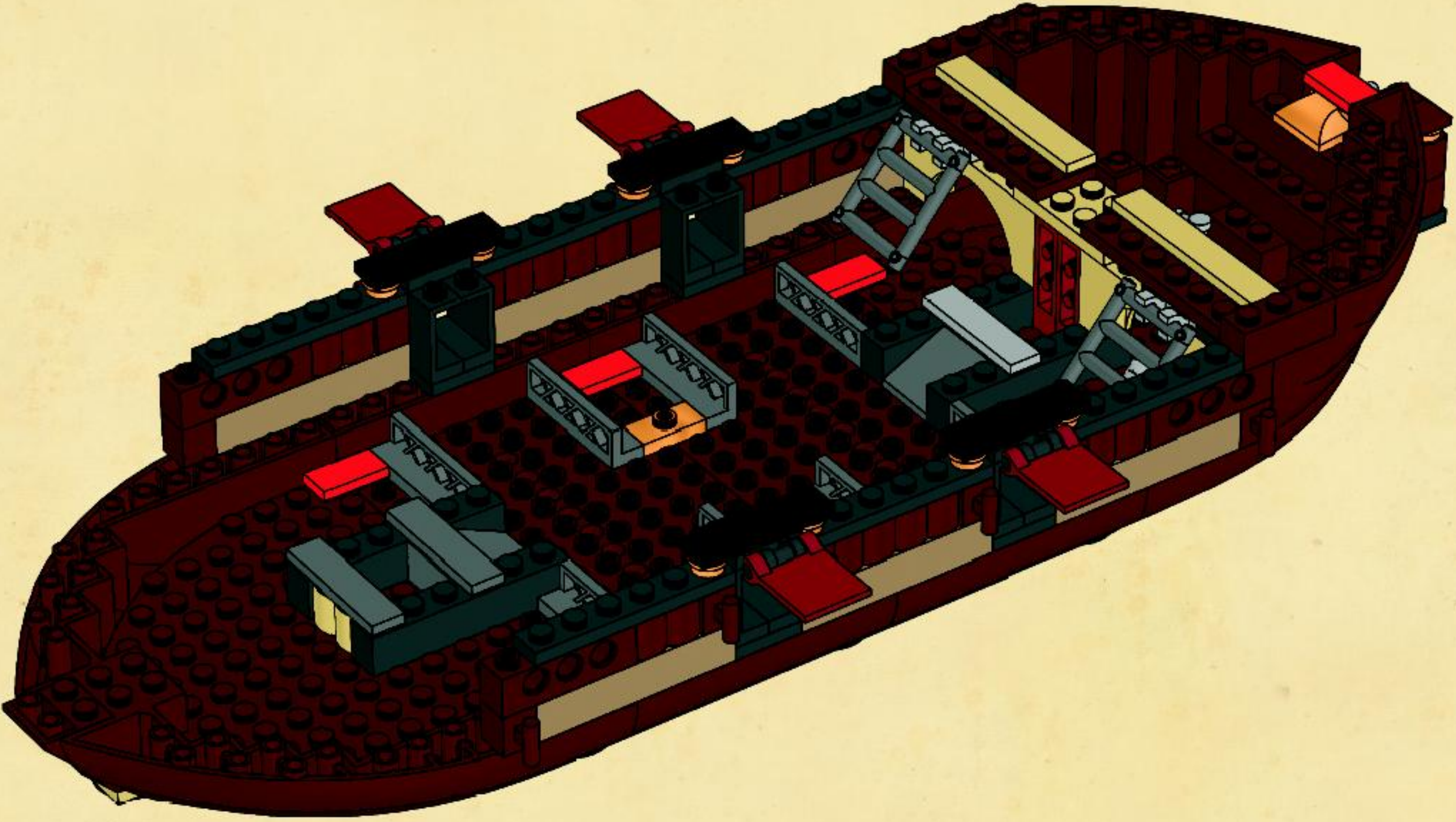

2x  2x  2x 

30

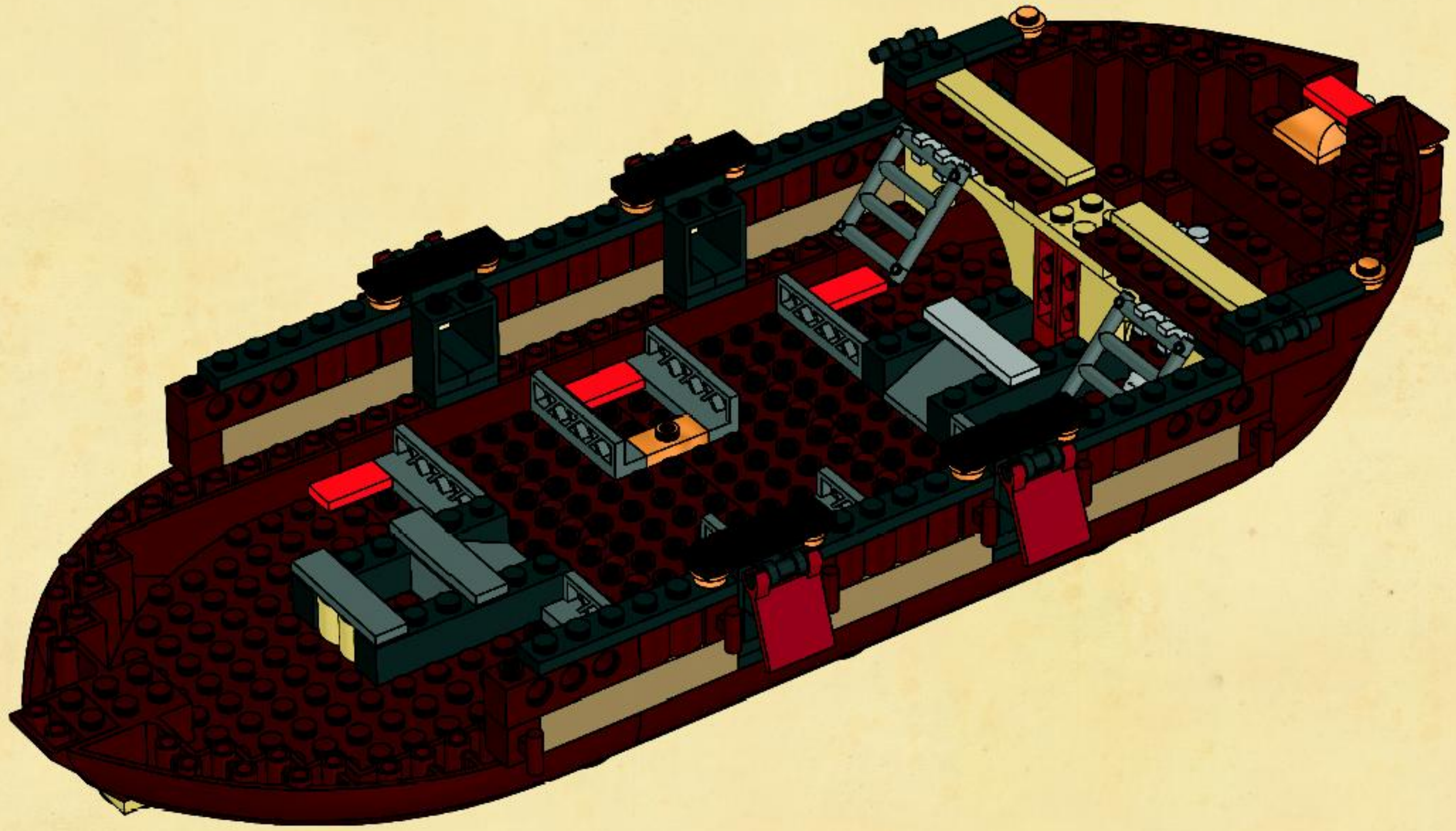

2x 4x 2x

31

2x

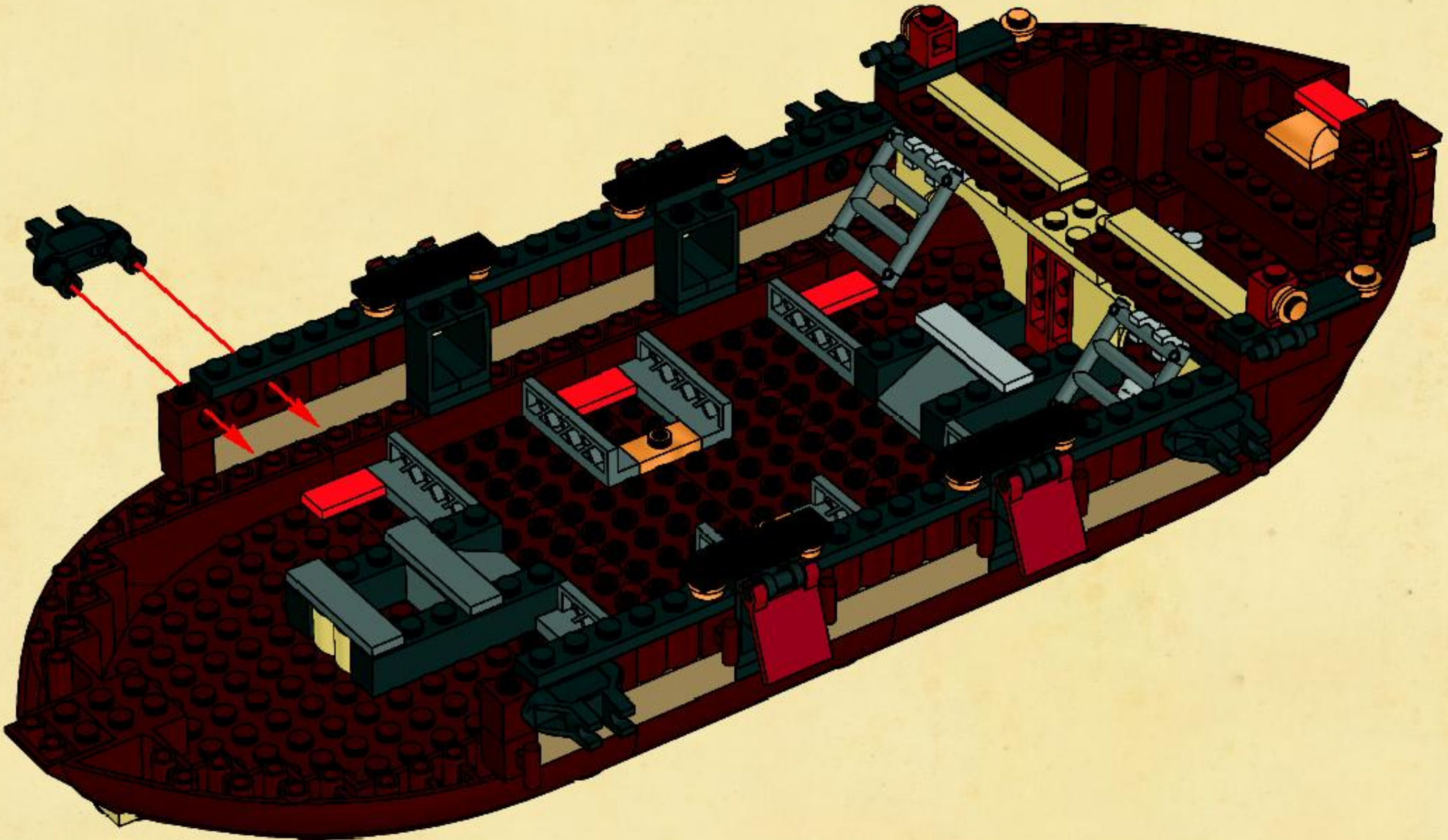

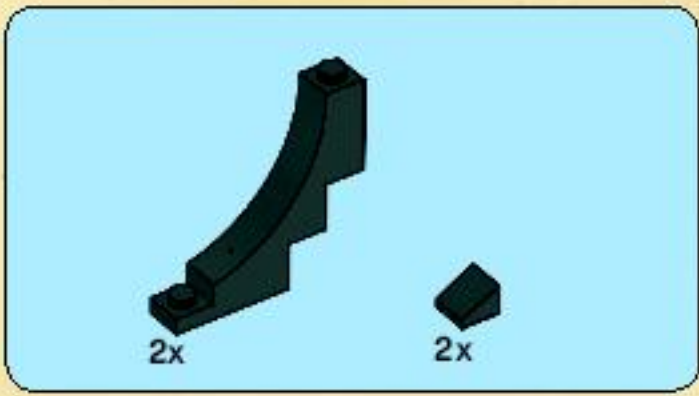

32

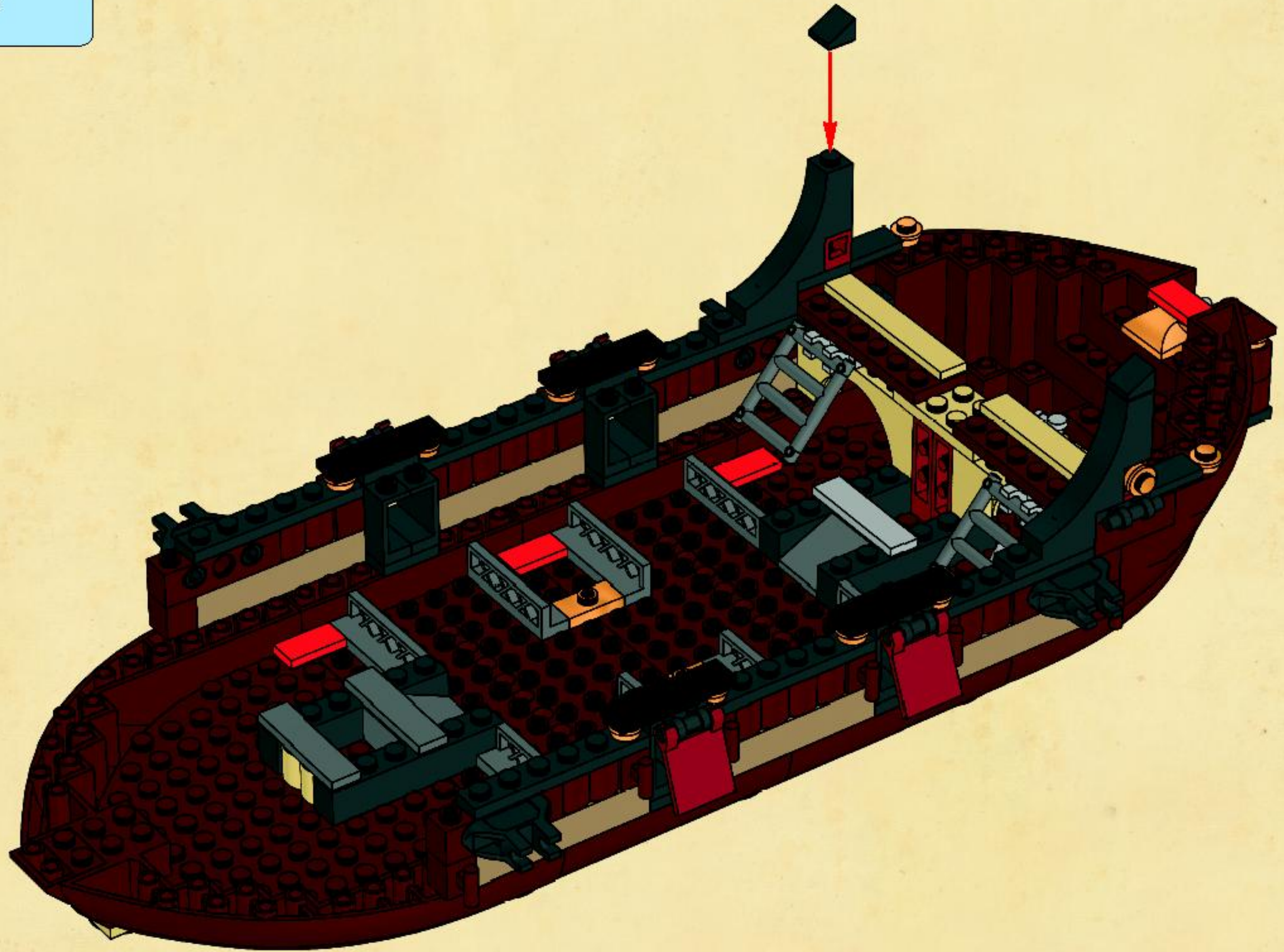

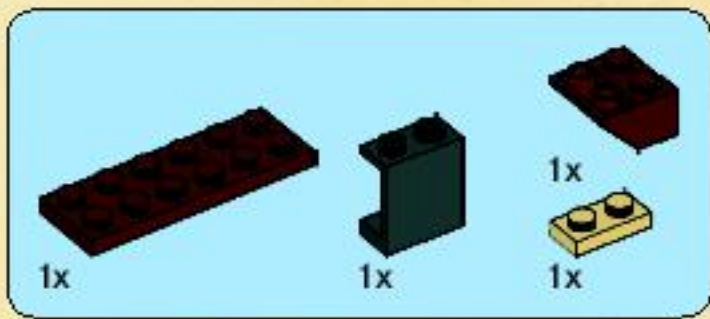

33

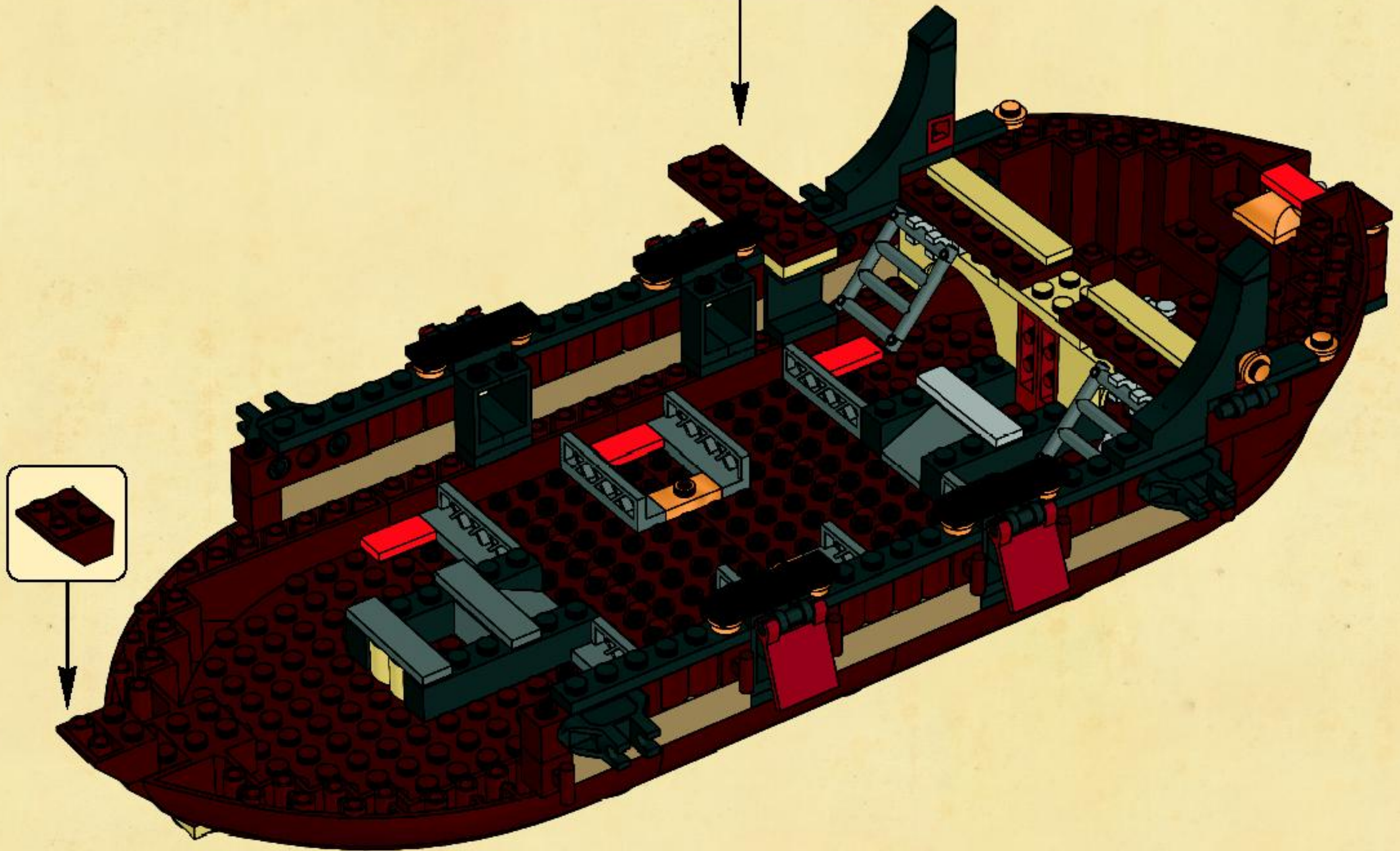
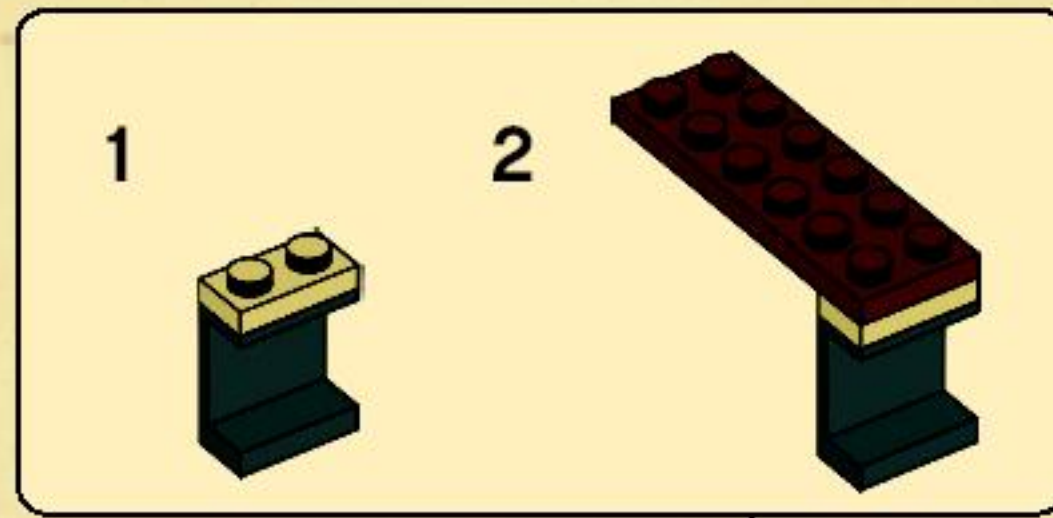



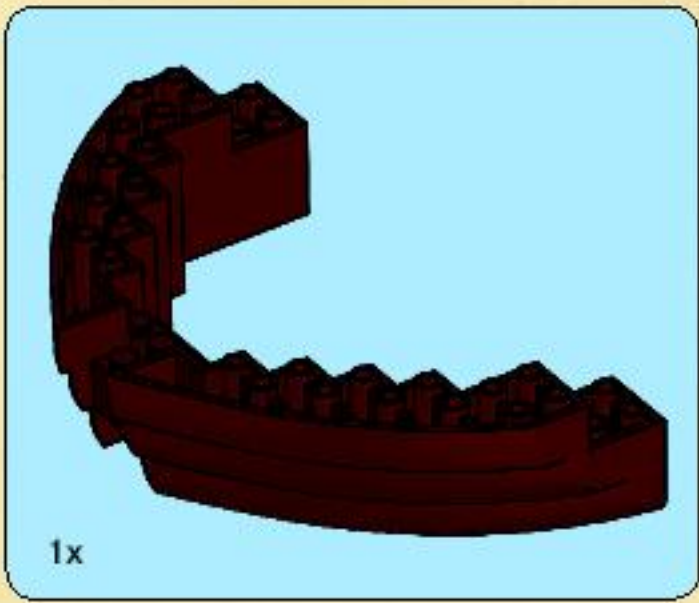

34

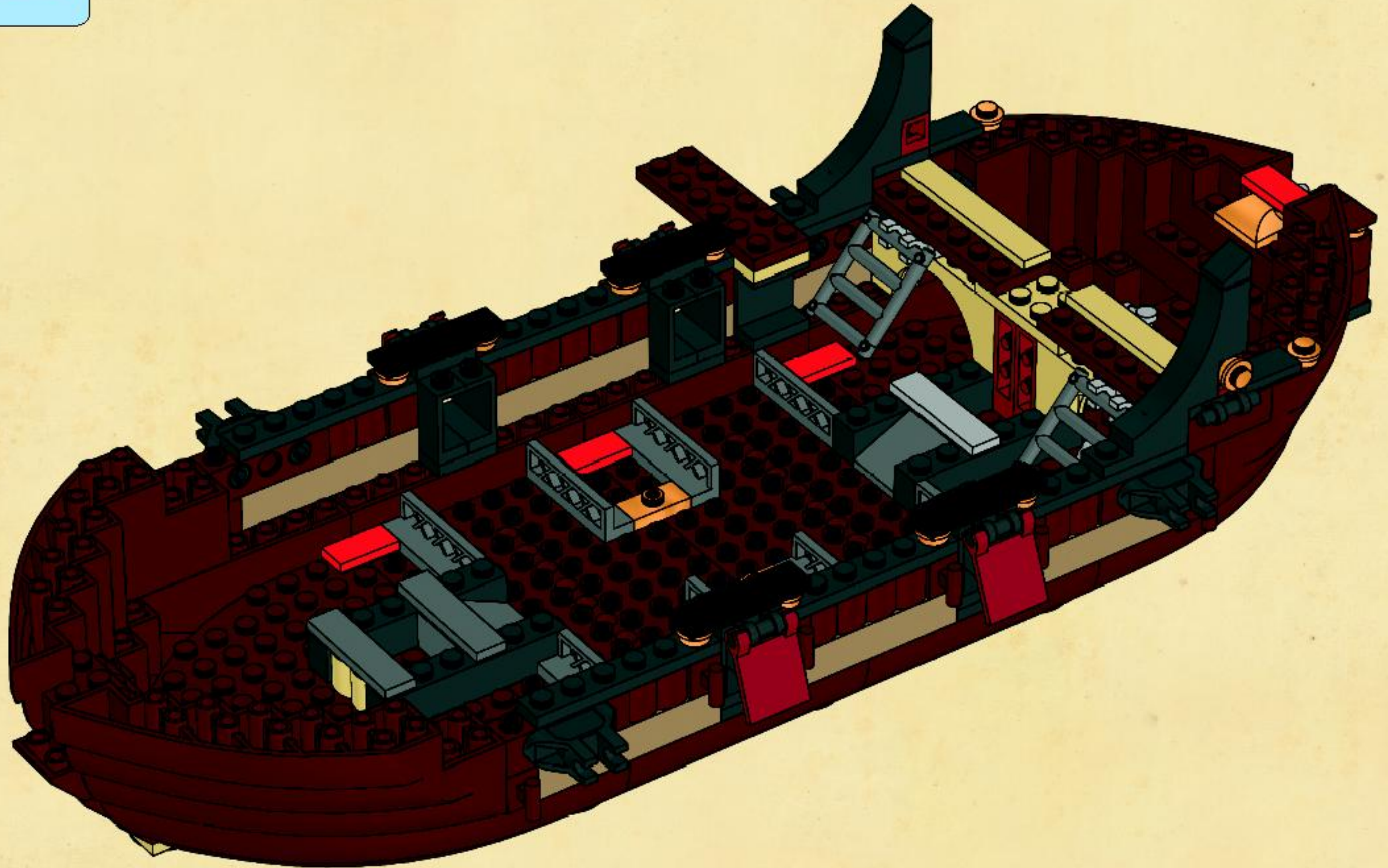

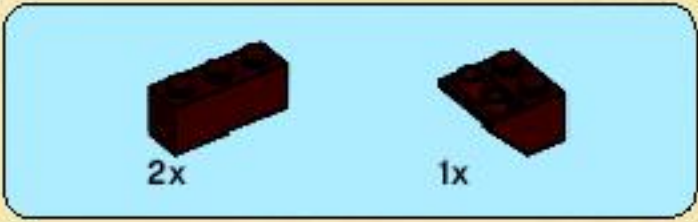

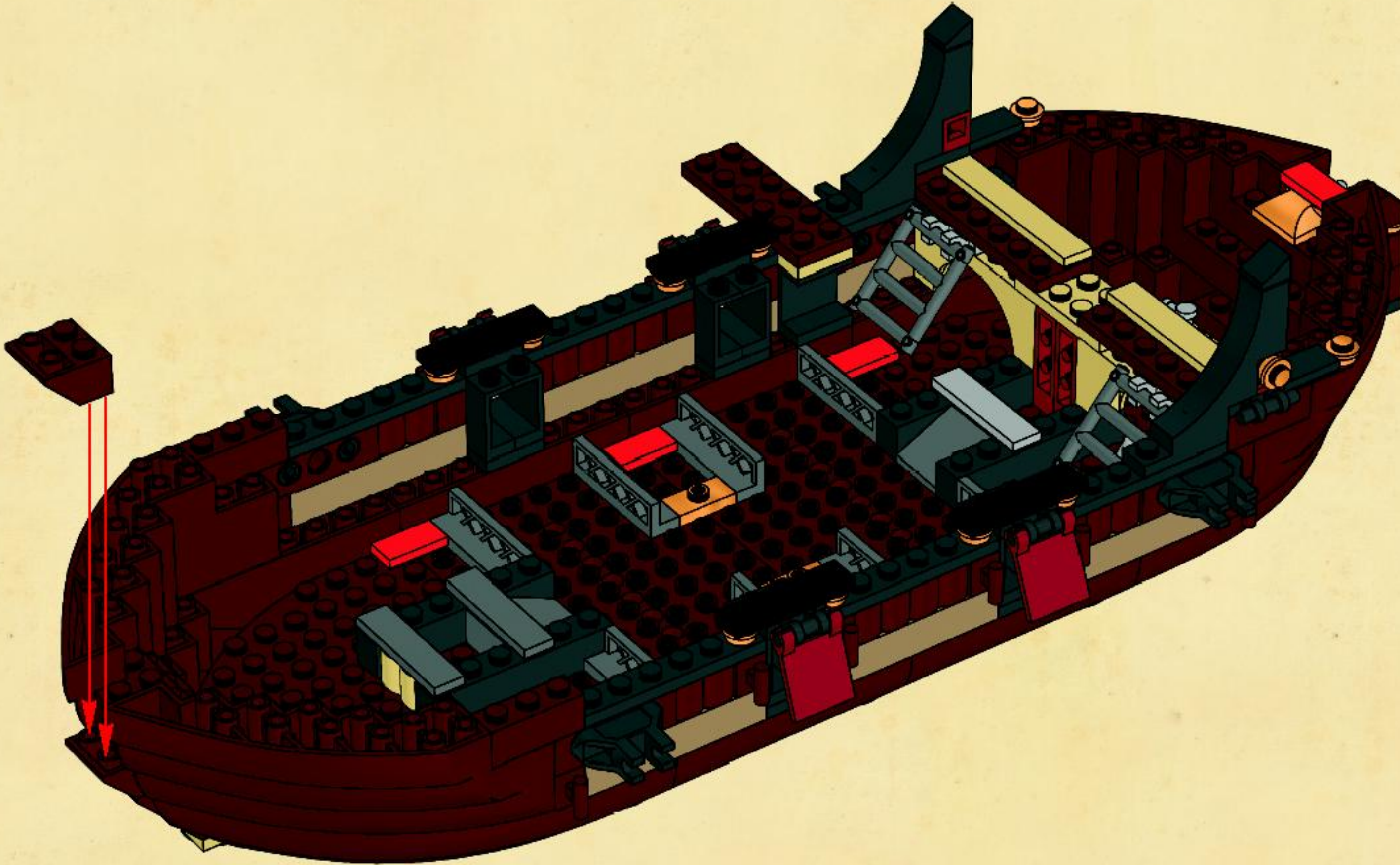

35

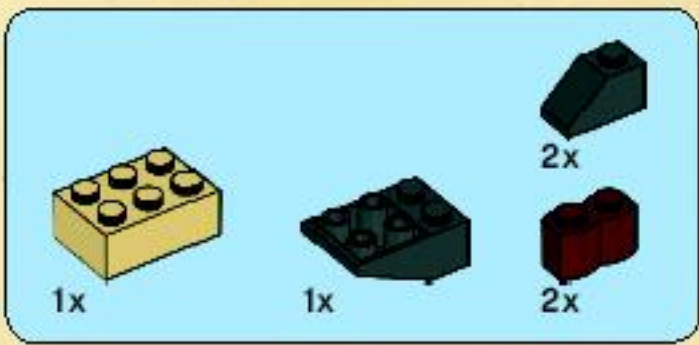

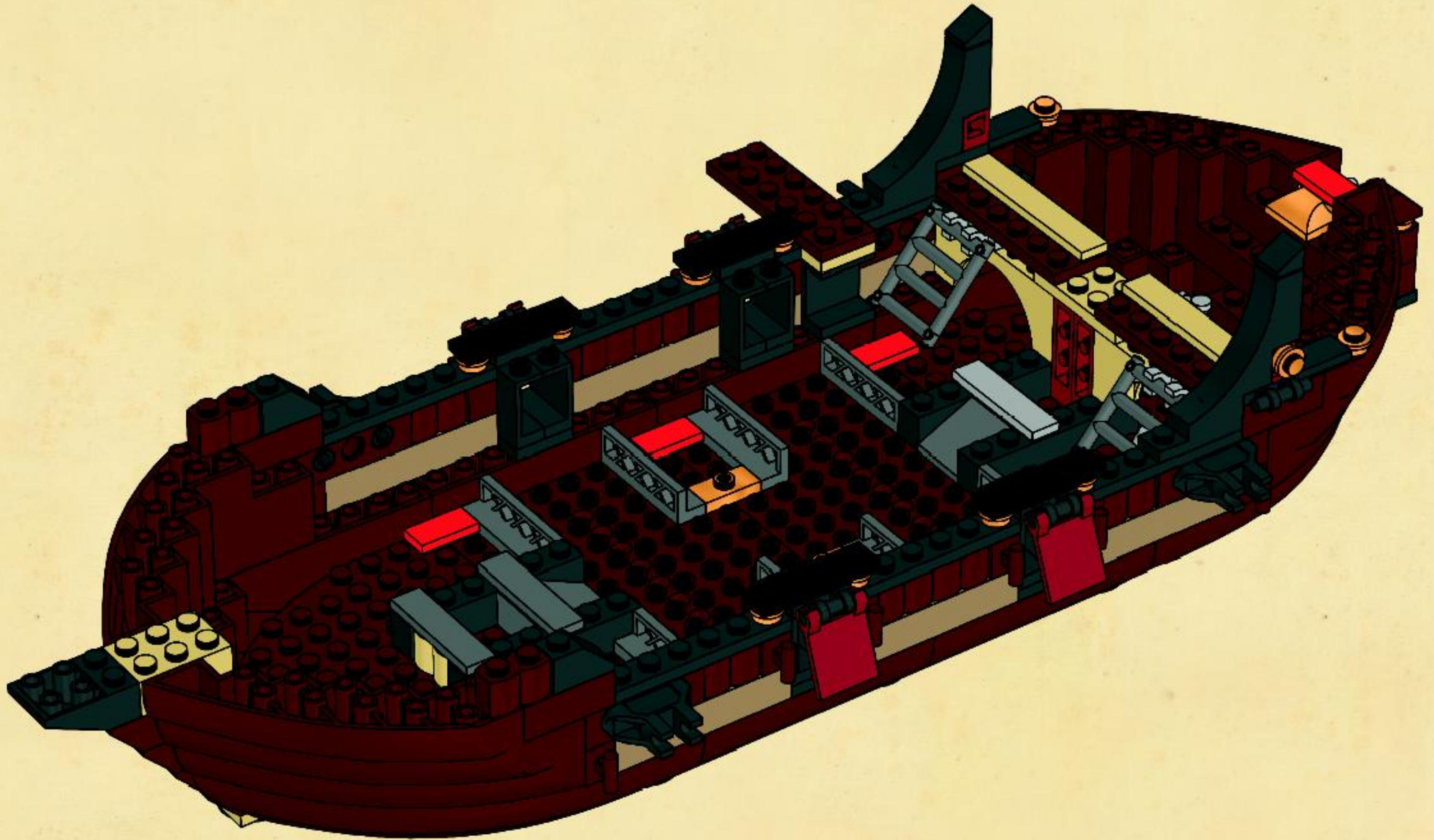

36



1x  2x 

37

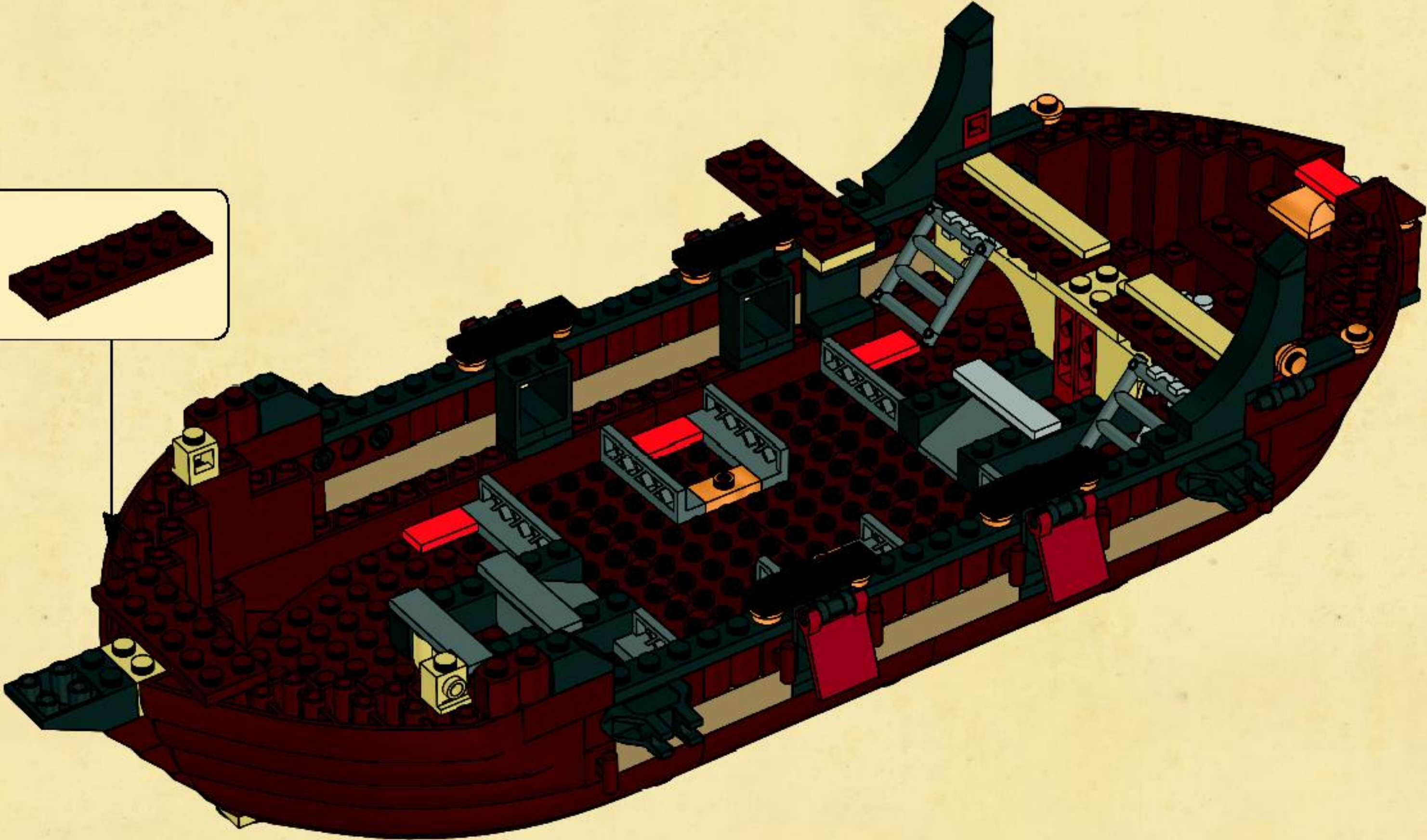
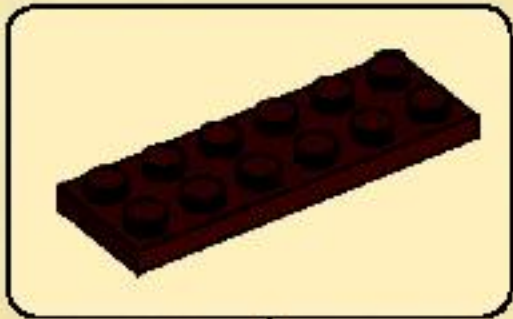

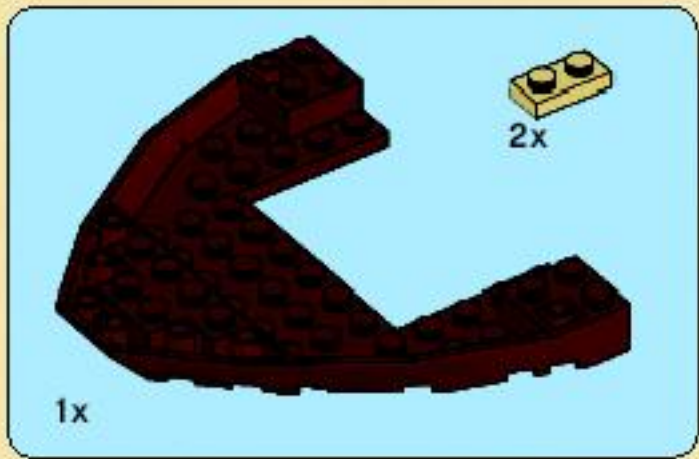

1

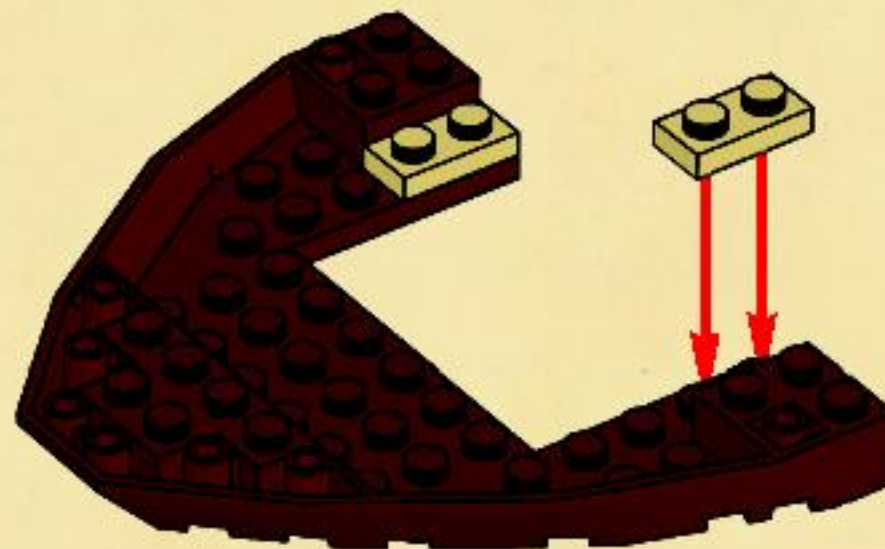

2

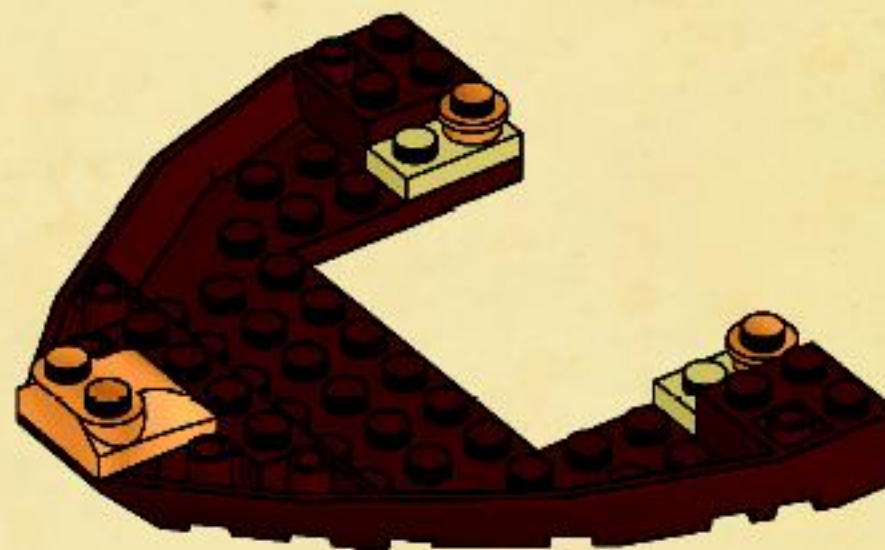

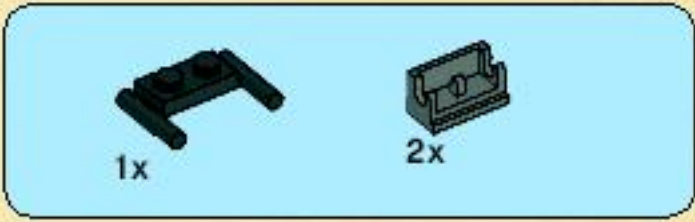

3

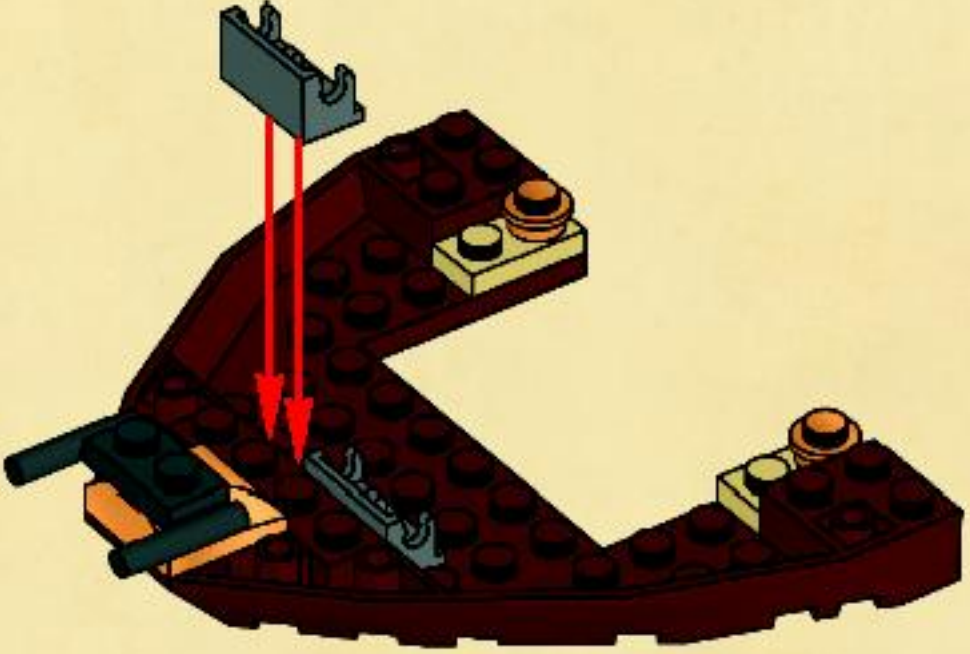

4





5



6

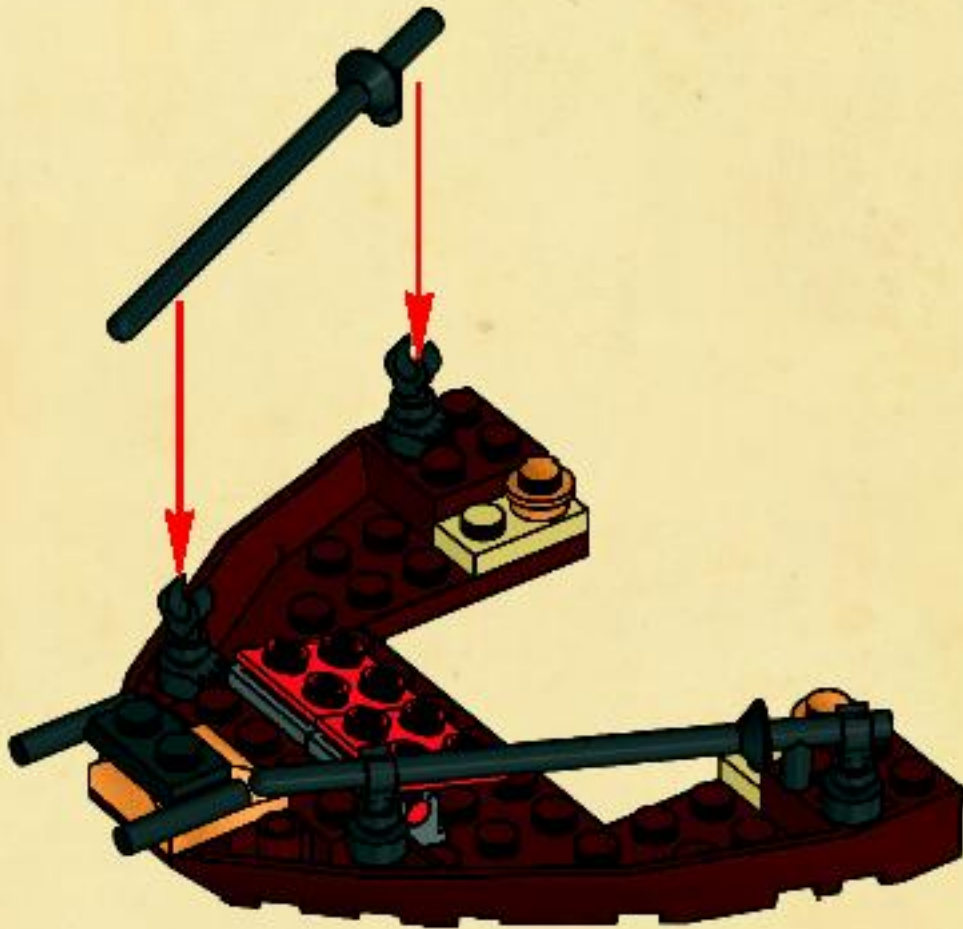

38

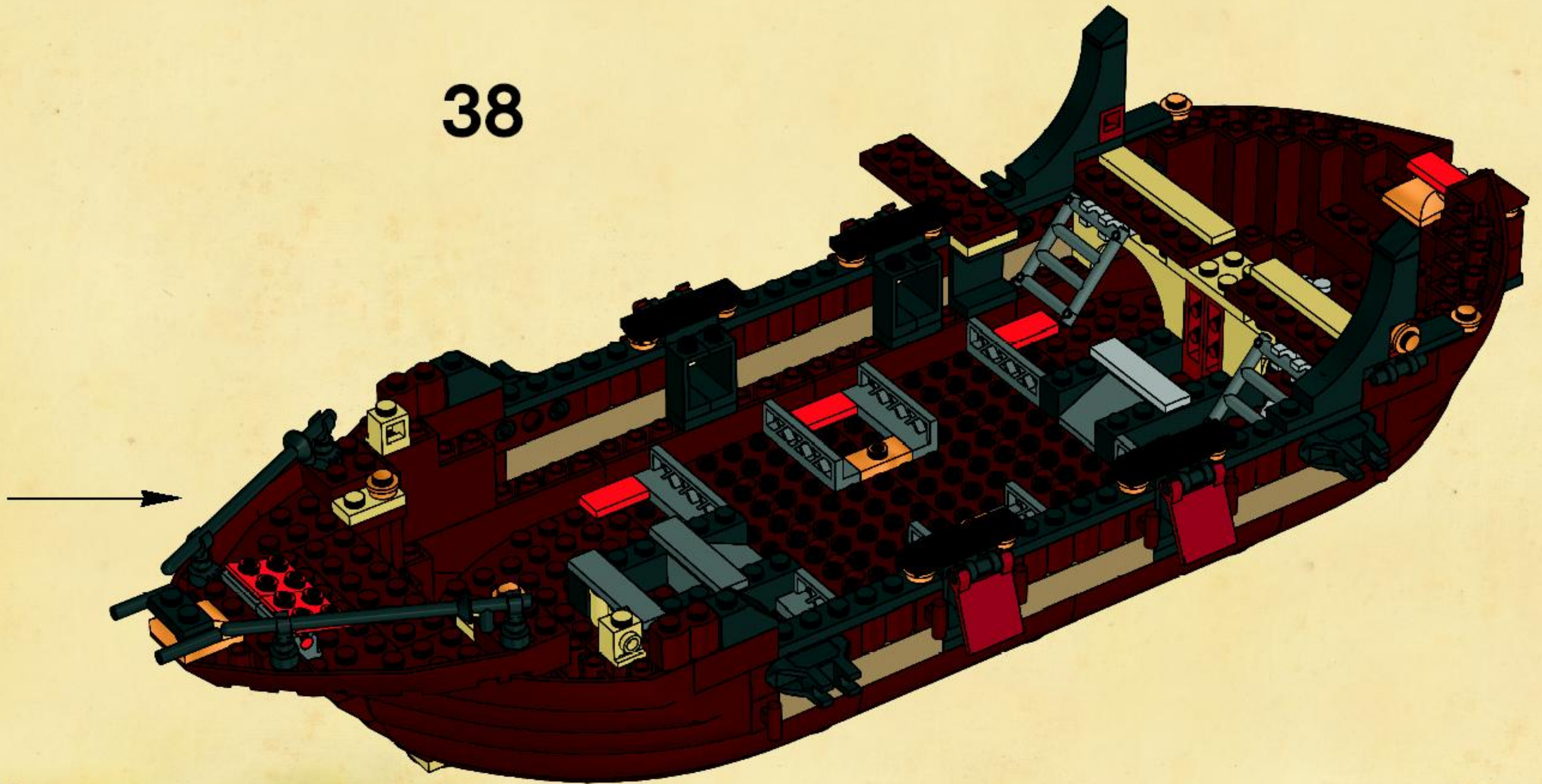



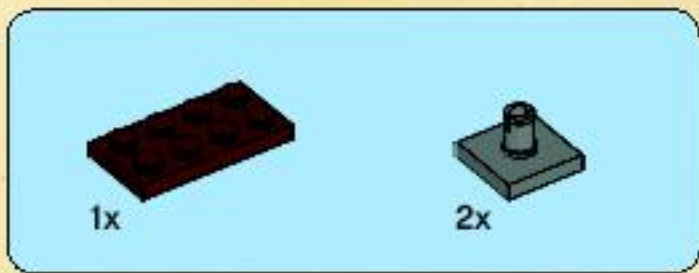

39

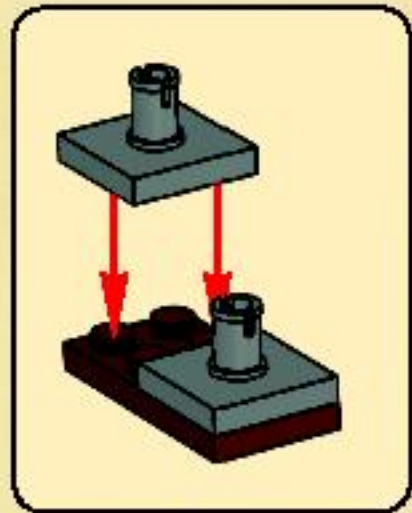
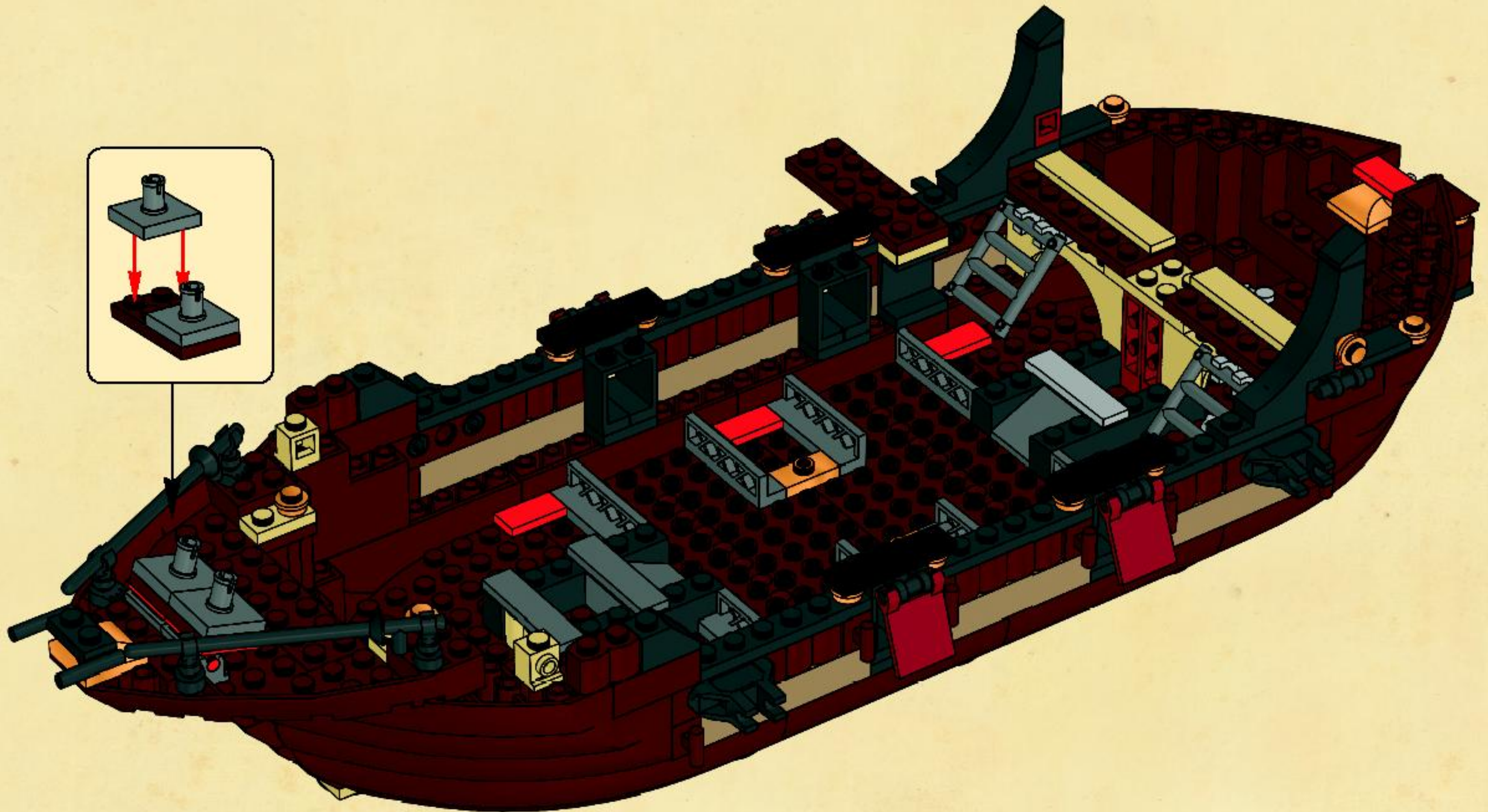

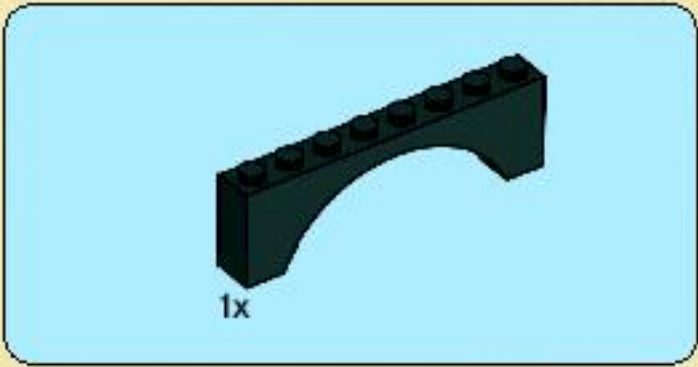

40

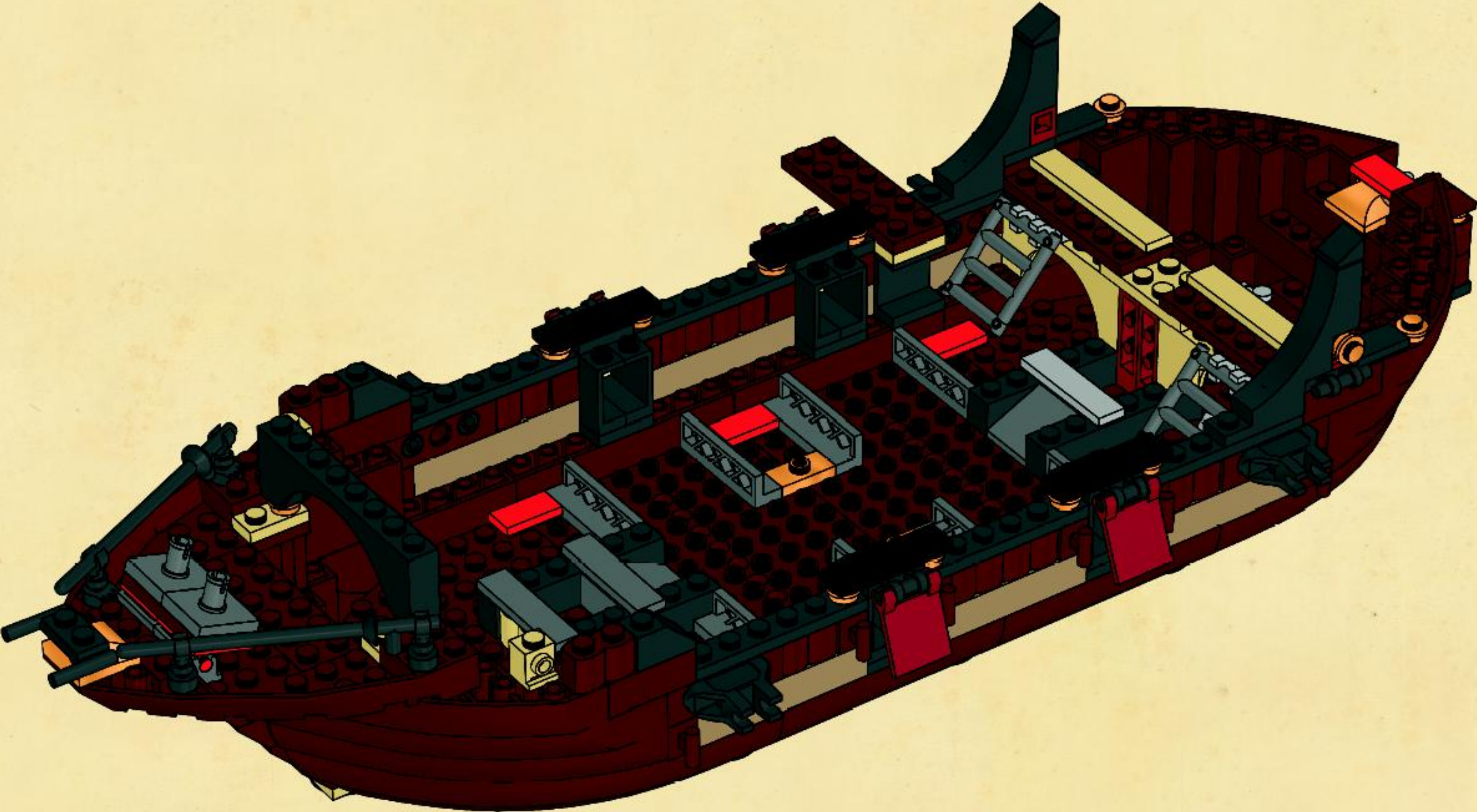

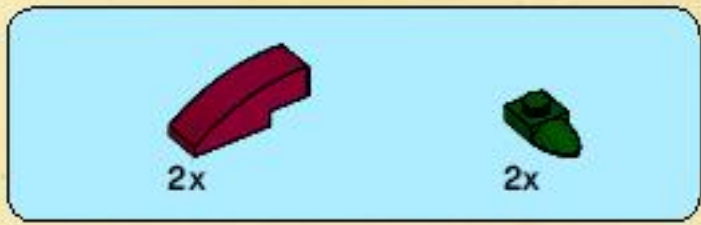

41

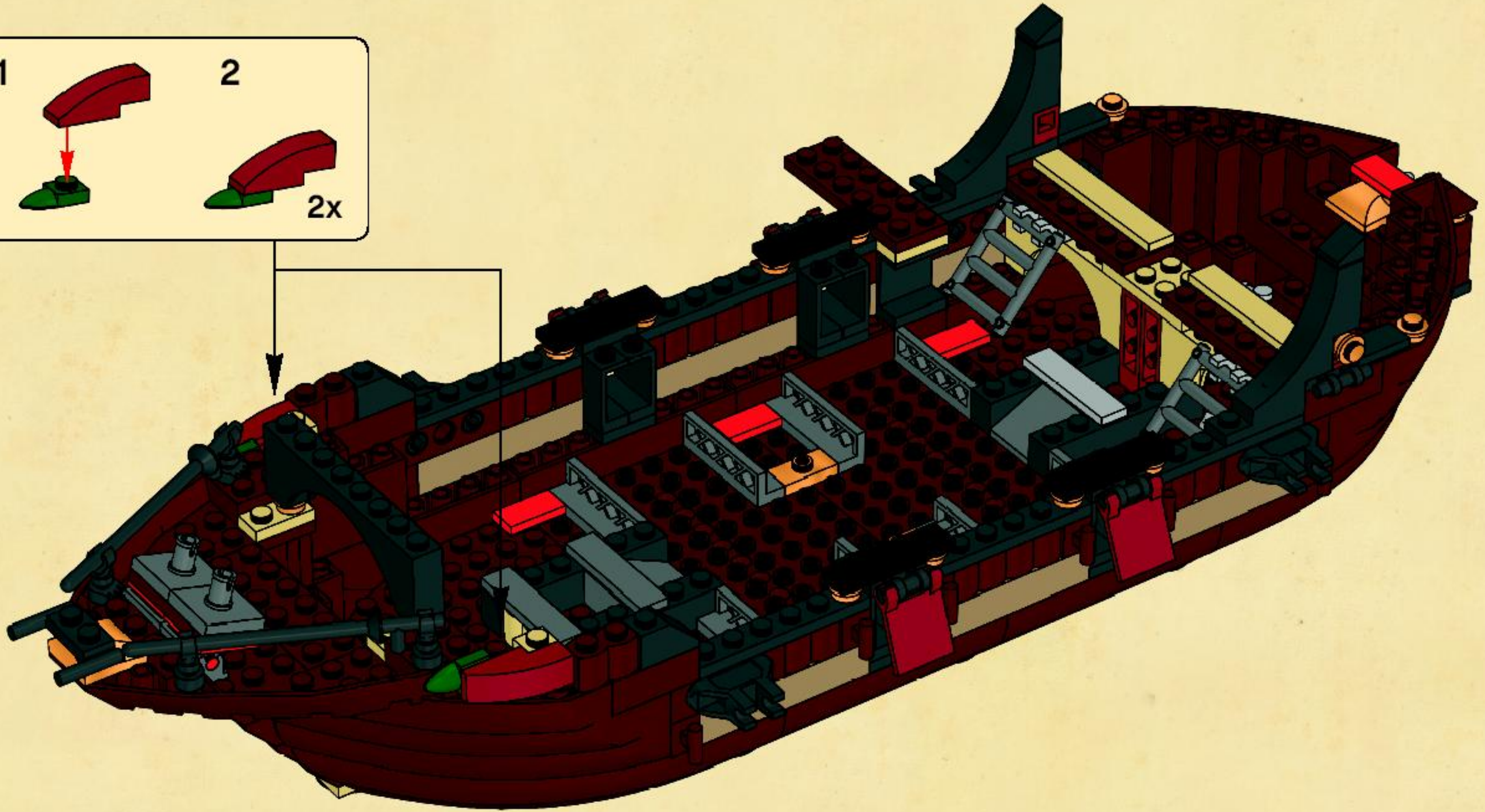
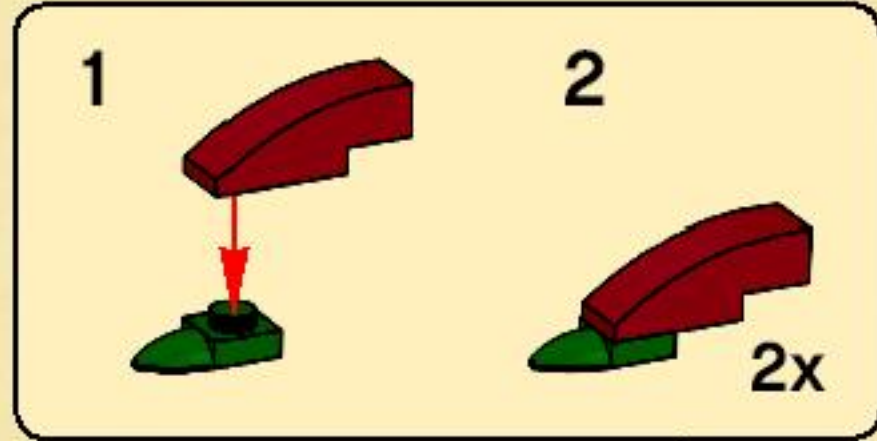

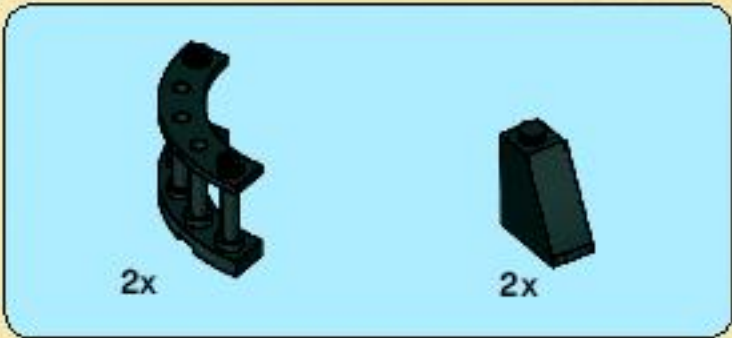

42

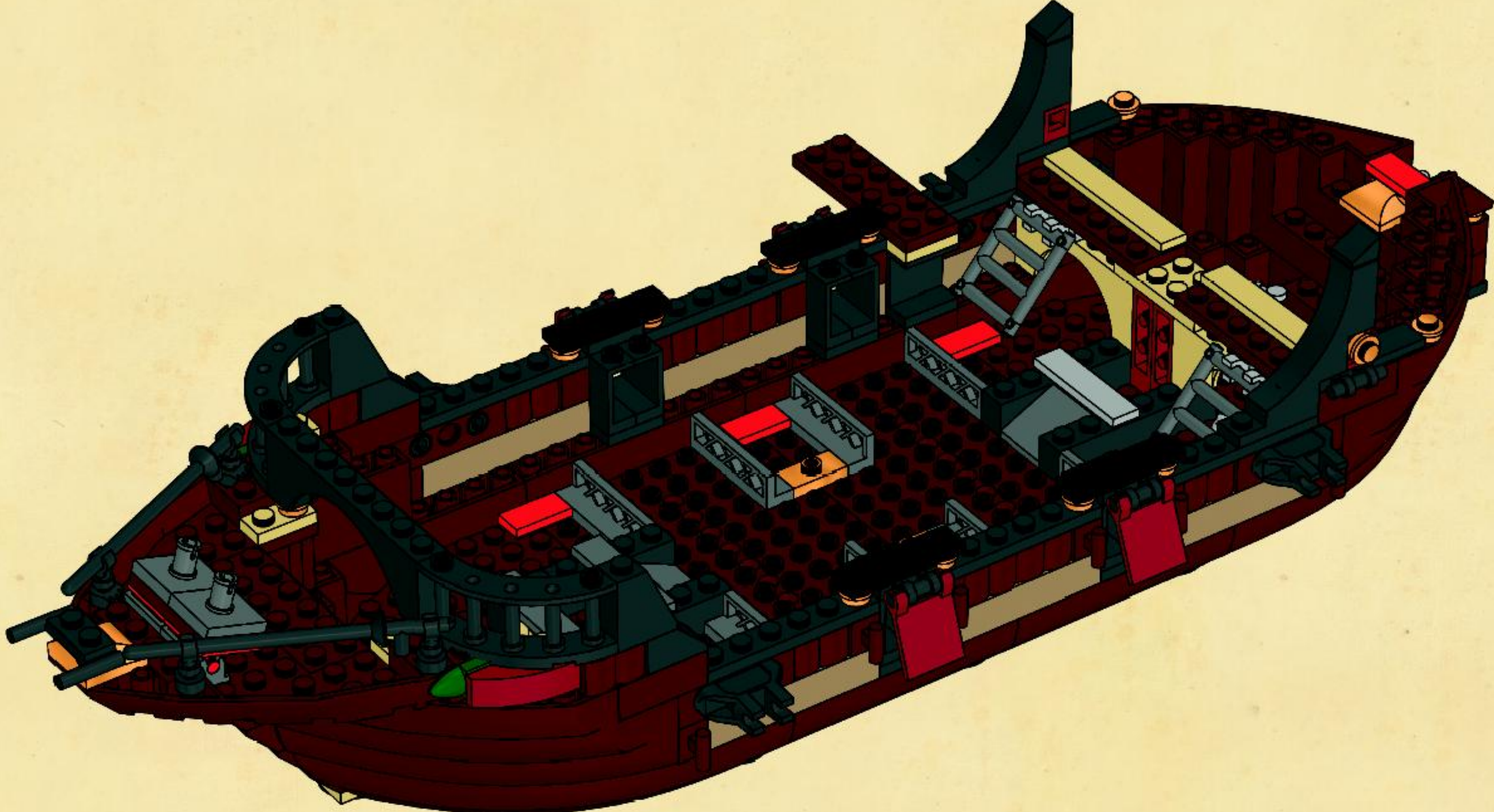



4x

43

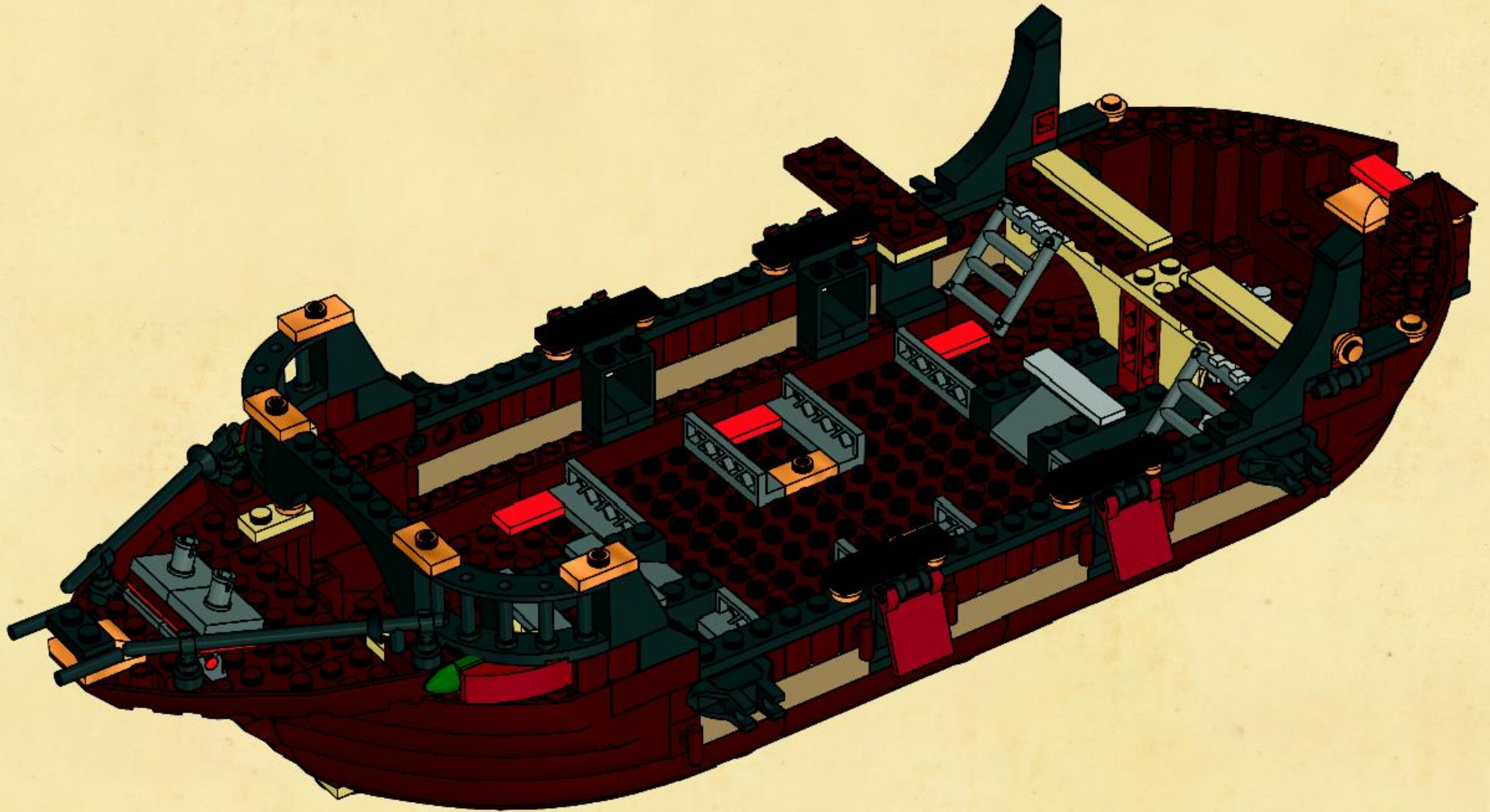

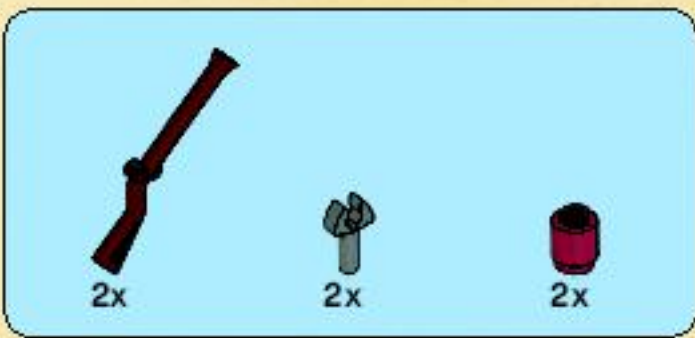

44

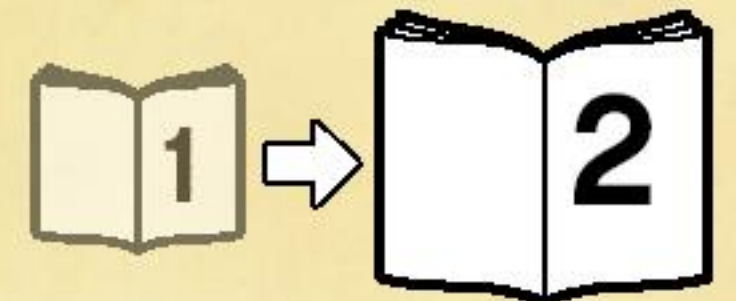
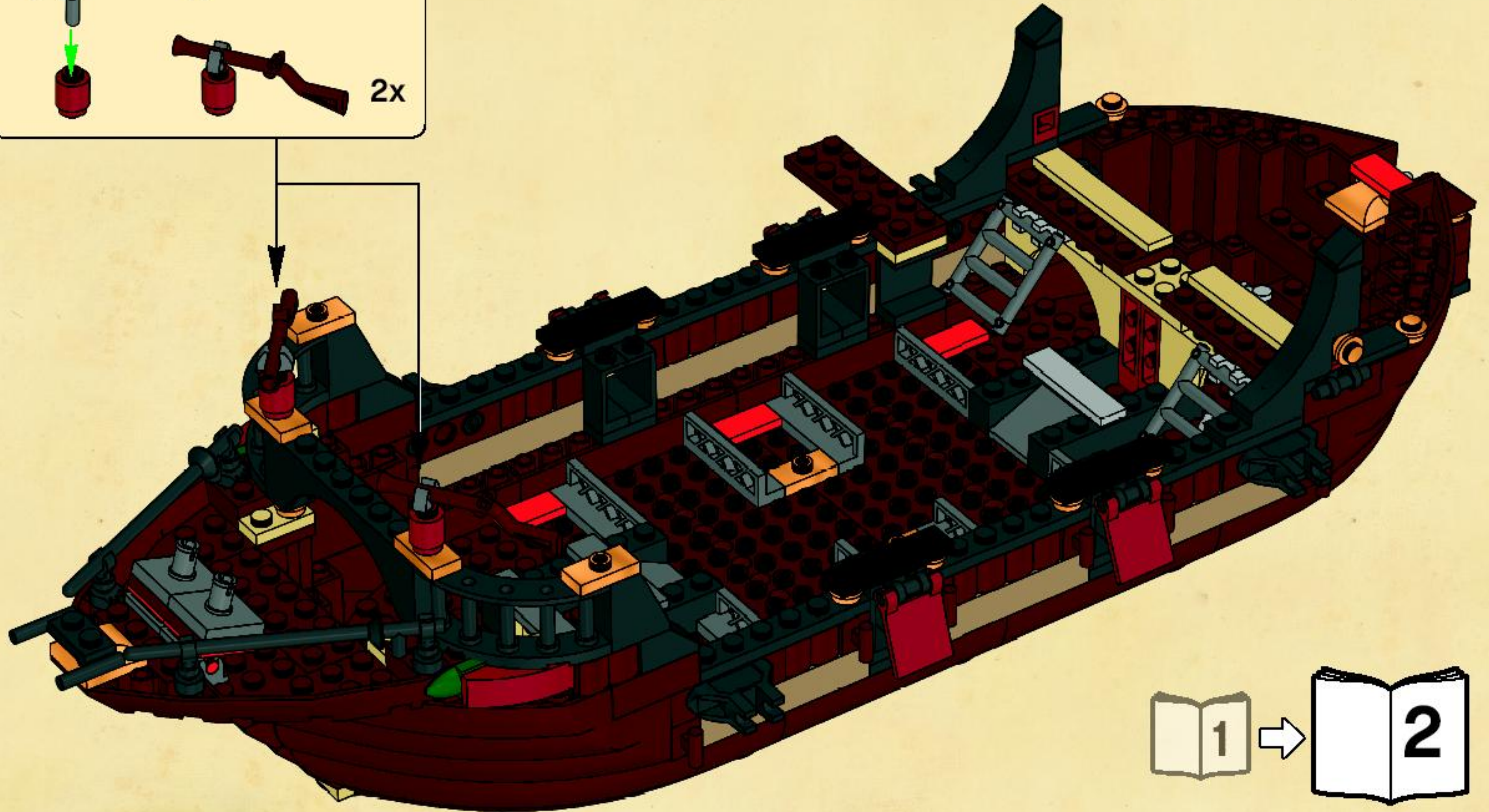
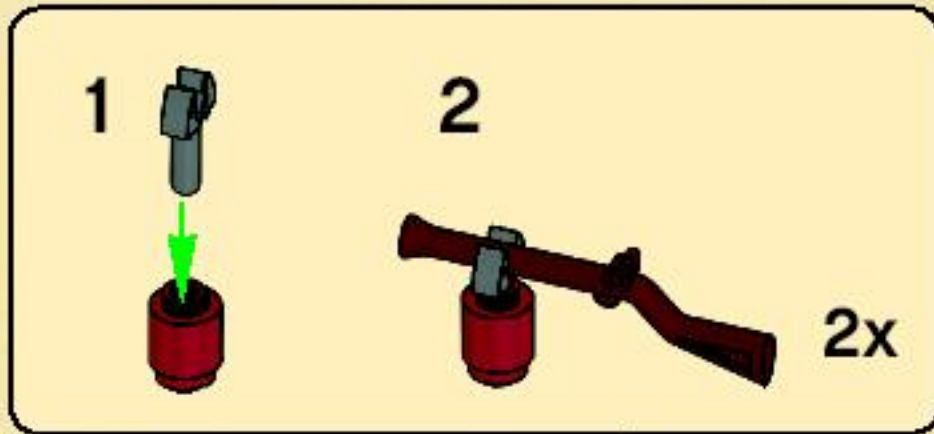



[www.nielsen.com/LEGO](http://www.nielsen.com/LEGO)



## WIN LEGO® PRODUCTS

Fill out a survey and you might WIN a cool LEGO product!  
NO PURCHASE NECESSARY  
Open to all residents where not prohibited  
Go to [www.acnielsen.aim.dk/LEGO](http://www.acnielsen.aim.dk/LEGO) to fill out a survey for a chance to win a LEGO product.

## WIN LEGO® PRODUCTEN

Vul een enquêteformulier in en maak kans op een cool LEGO® product!  
Kopen niet nodig  
Iedereen uit landen waar geen enquêteverbod geldt mag deelnemen.  
Ga naar [www.acnielsen.aim.dk/LEGO](http://www.acnielsen.aim.dk/LEGO), vul een enquêteformulier in en maak kans op een LEGO product.

## GEWINNE LEGO® PRODUKTE

Nimm an der Umfrage teil und GEWINNE ein tolles LEGO® Produkt!  
Die Teilnahme am Gewinnspiel führt zu keinerlei Kaufverpflichtungen  
Teilnahme in allen nicht ausgeschlossenen Ländern möglich  
Wir verlosen unter allen Teilnehmern der Umfrage auf [www.acnielsen.aim.dk/LEGO](http://www.acnielsen.aim.dk/LEGO) LEGO Produkte.

## GAGNE DES PRODUITS LEGO®

Réponds à un questionnaire et tu pourras GAGNER un produit LEGO® très cool !  
Aucune obligation d'achat.  
Ouvert à tous les résidents des pays autorisés.  
Visite [www.acnielsen.aim.dk/LEGO](http://www.acnielsen.aim.dk/LEGO) pour répondre à un questionnaire et avoir une chance de gagner un produit LEGO.

## レゴ®製品を「当てよう」

アンケートに記入して、かっこいいレゴ®製品を当てよう！  
お買い上げの必要はありません。禁止されていない限り、すべての皆様にご利用いただけます。  
[www.acnielsen.aim.dk/LEGO](http://www.acnielsen.aim.dk/LEGO)にアクセスして、アンケートにご記入ください。当選者にはレゴ®製品を差し上げます。



[www.LEGO.com](http://www.LEGO.com)

©2009 The LEGO Group. 4550863