

LEGO

# NINJAGO

Masters of Spinjitzu

2521



1

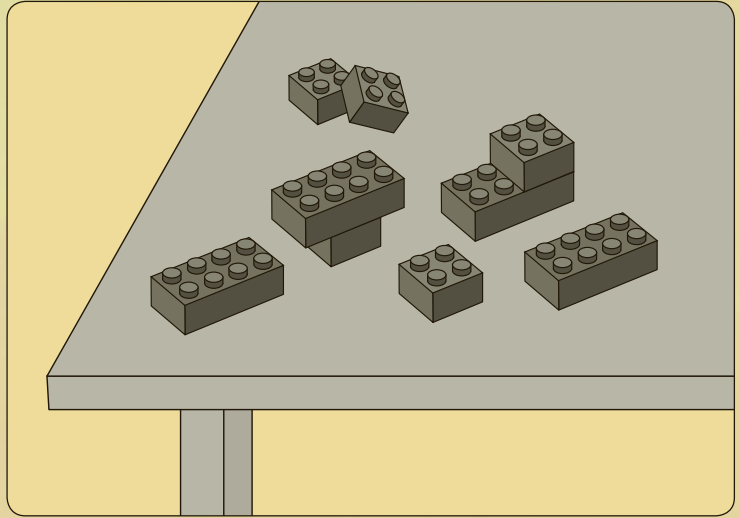
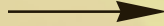
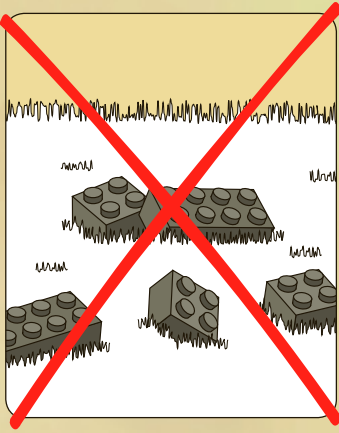

2



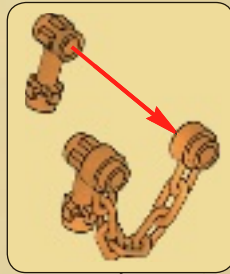
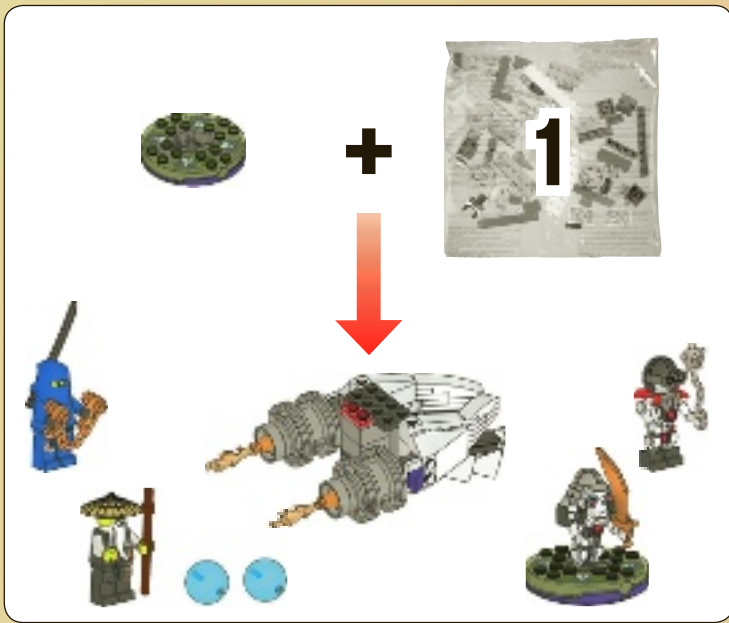

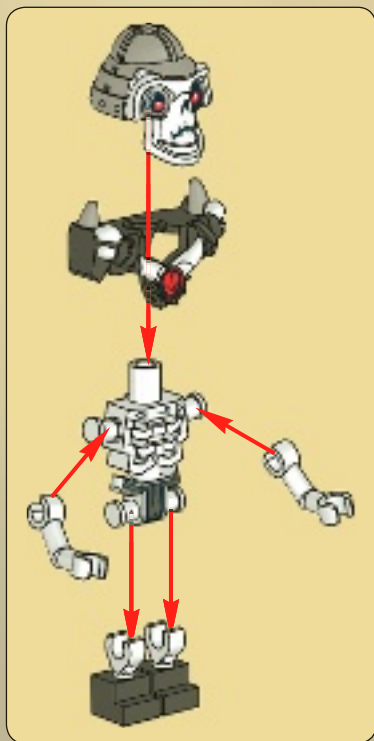

1



2



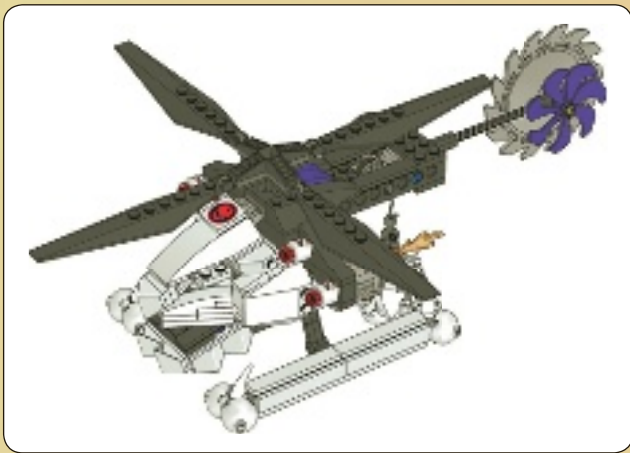

1

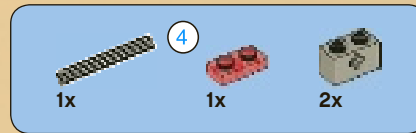

2

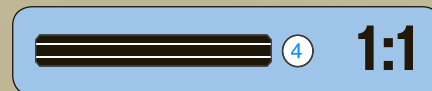
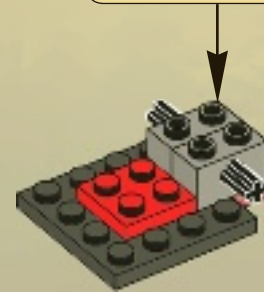
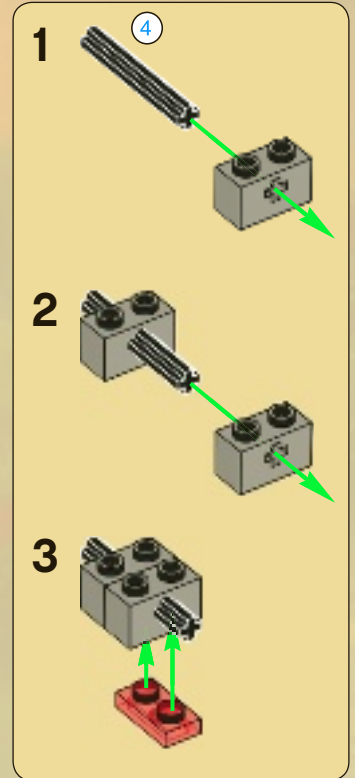

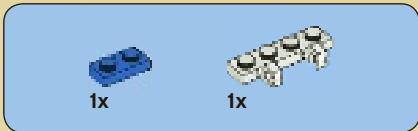

3

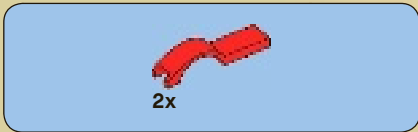

4

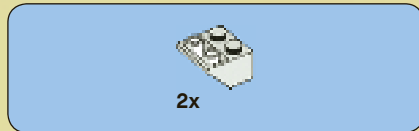
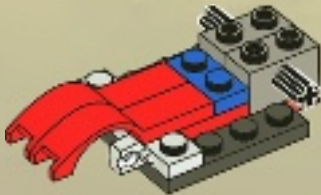

5

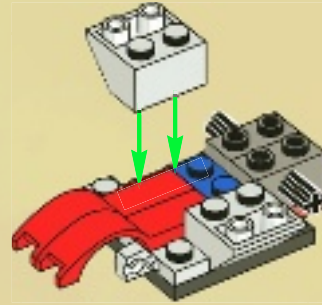

6





7

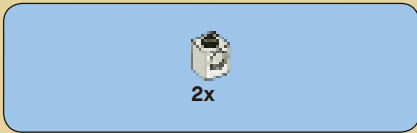

8

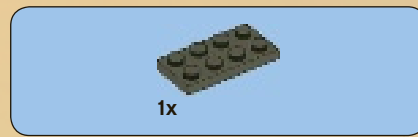

9



10

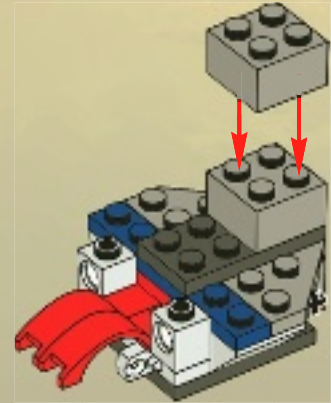

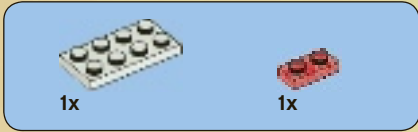

1

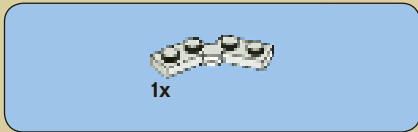

2

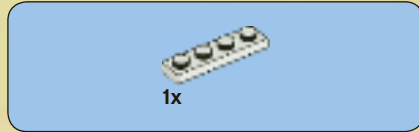

3



4

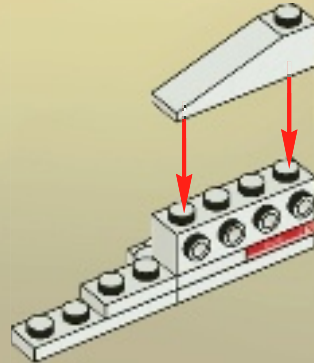





1x

5

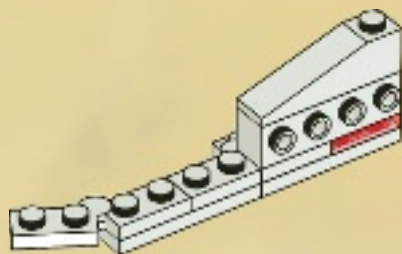

1x

6

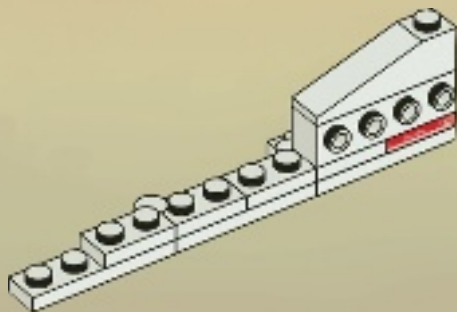

1x



1x

7

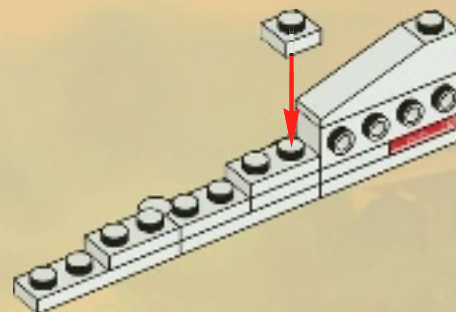

1x

8

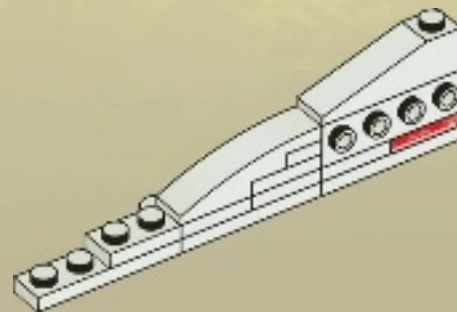



1x

9

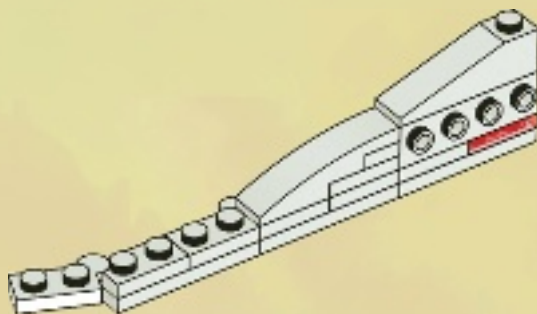

1x

10

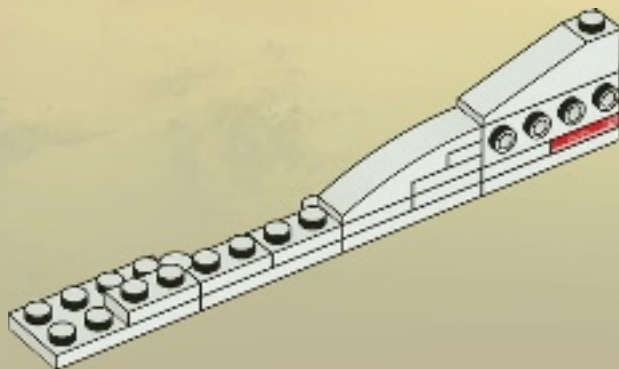

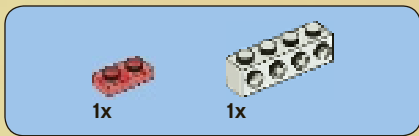

11

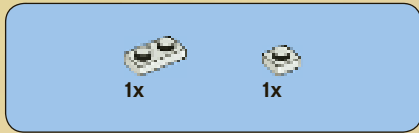
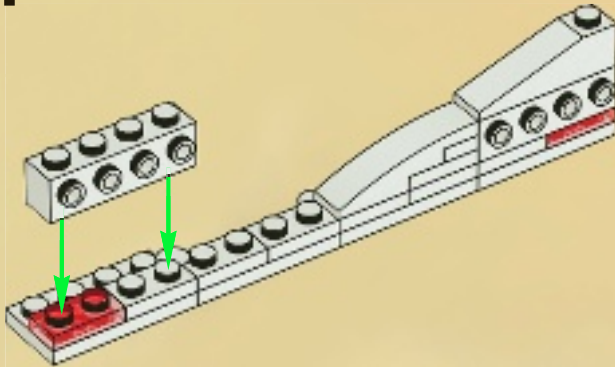

12

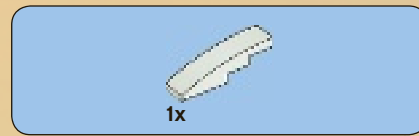
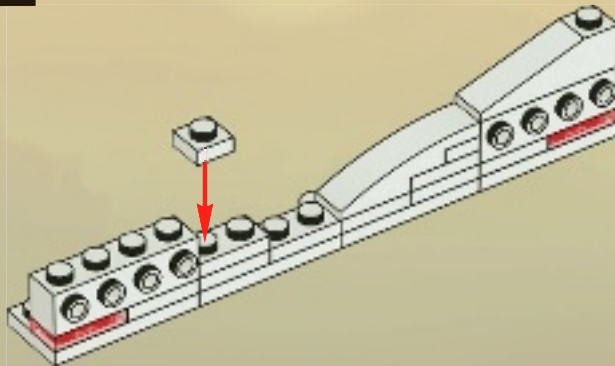

13

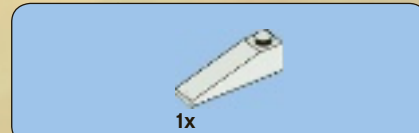
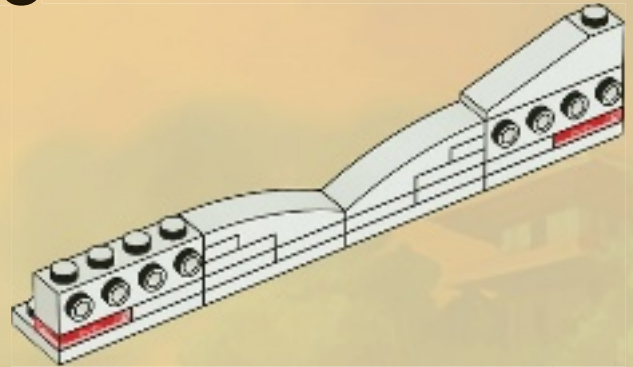

14

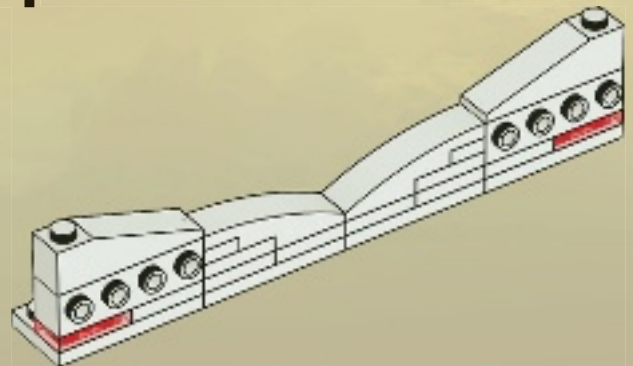

# 15

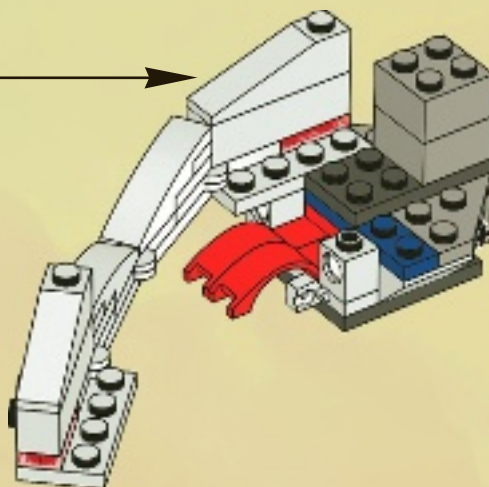

1x

# 16

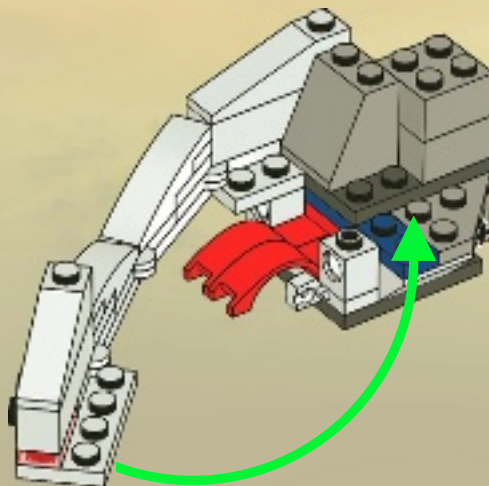



1x

# 17

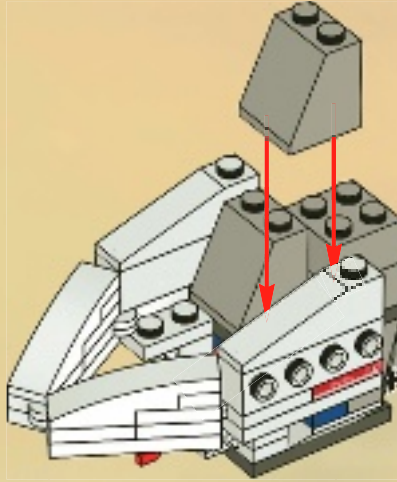

1x



1x

# 18

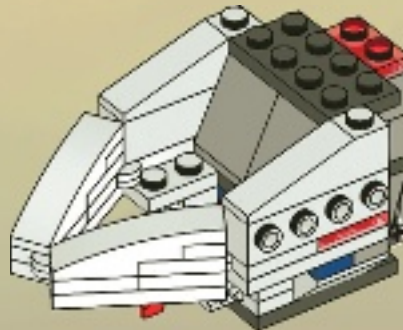



1x

1



1x

2



3x

3

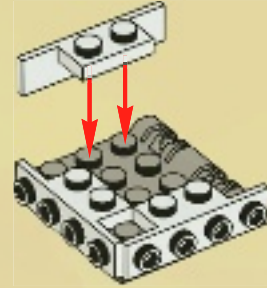

2x



2x

4





5

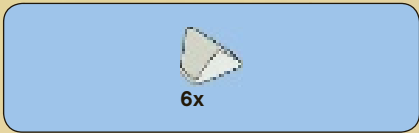

6

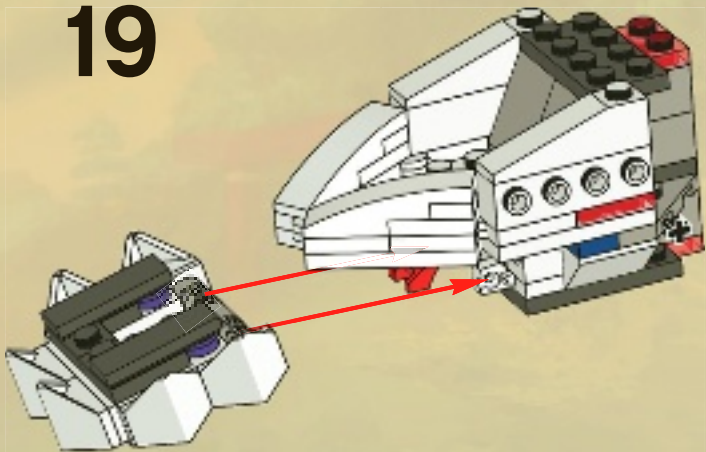
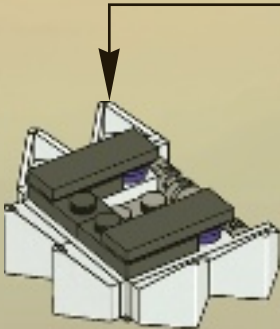

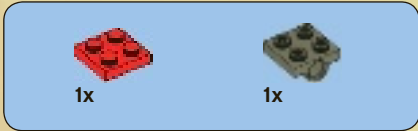

1



2

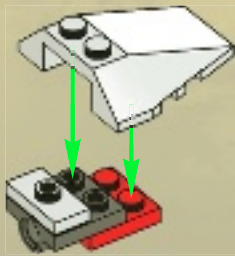

3

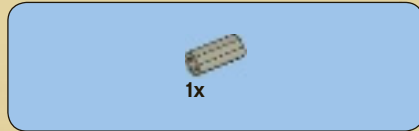
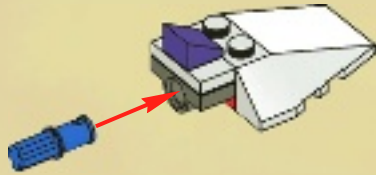

4

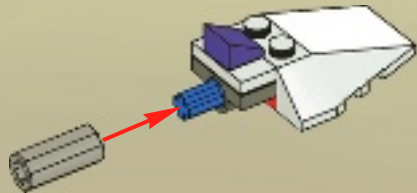





5

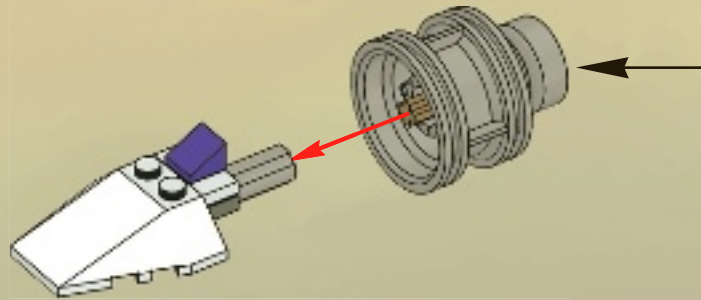
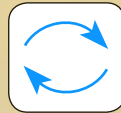
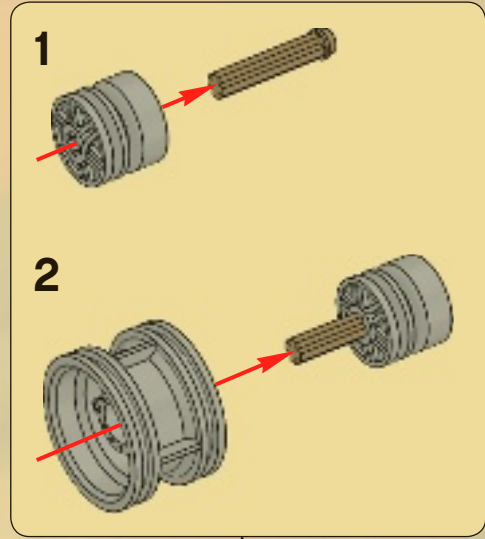



1x

6

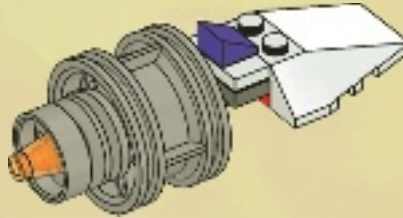

1x

7

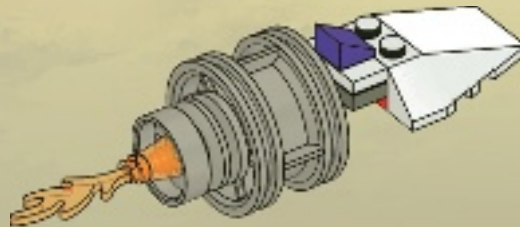

2x

20

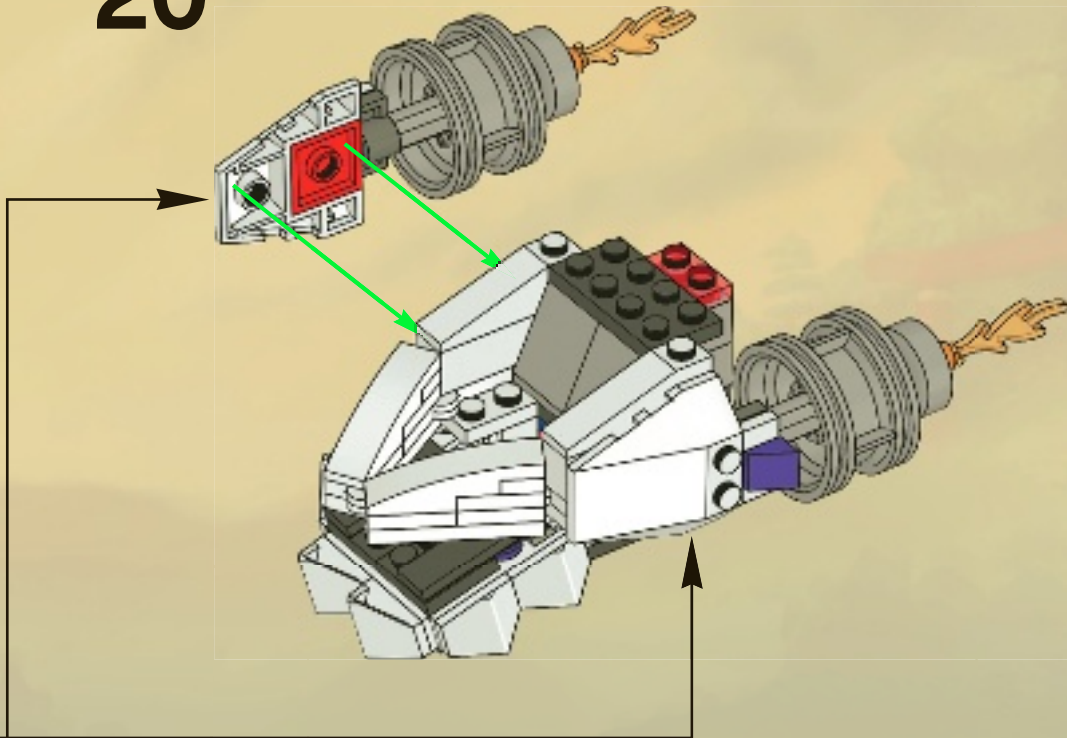

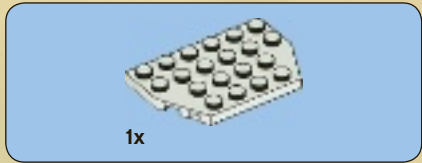
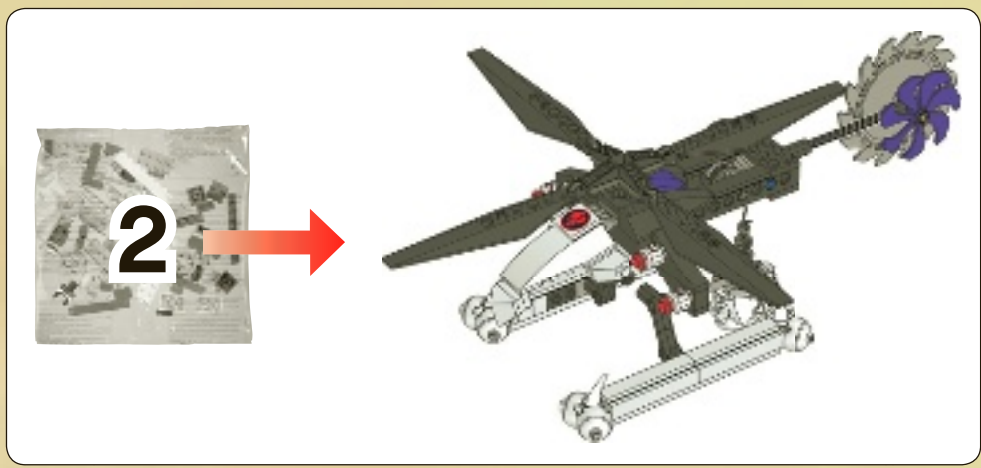

21

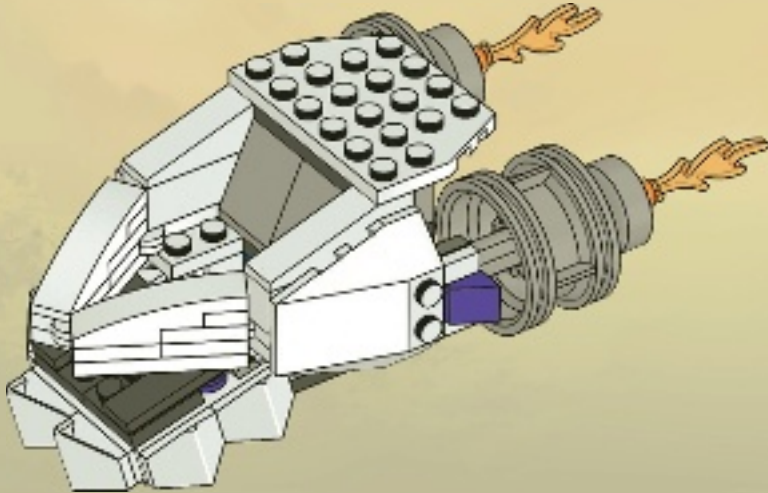

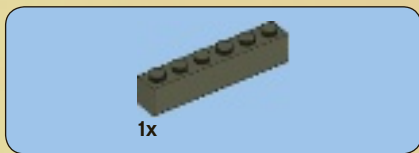

22

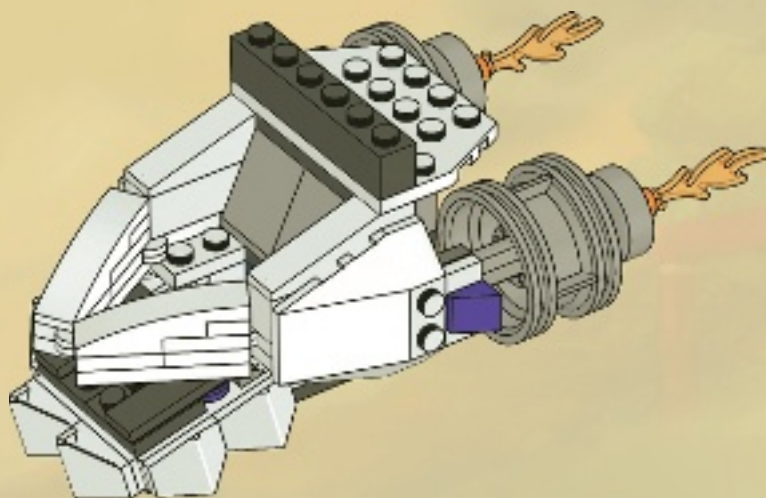

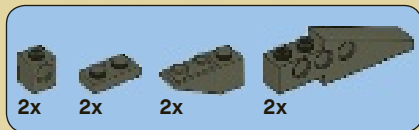

# 23

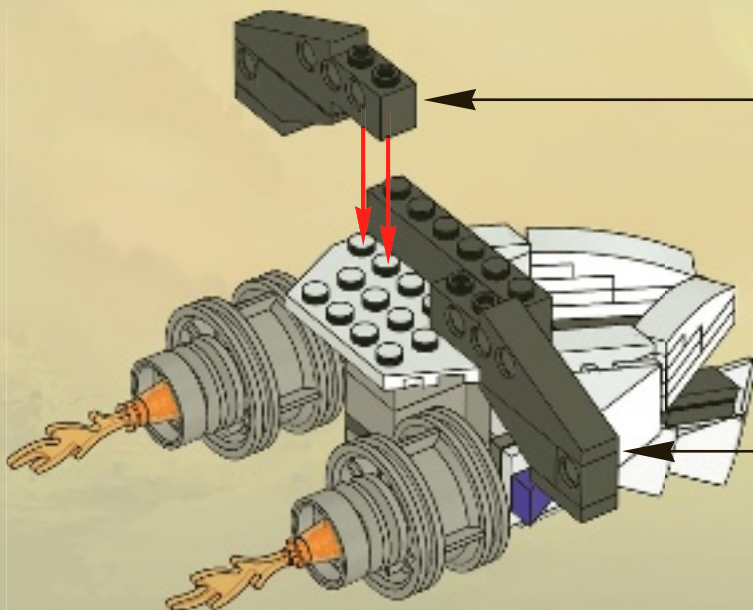

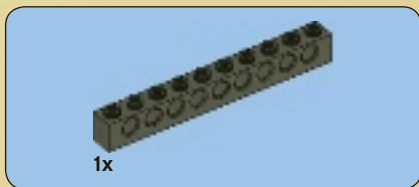

24

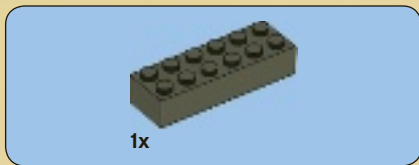
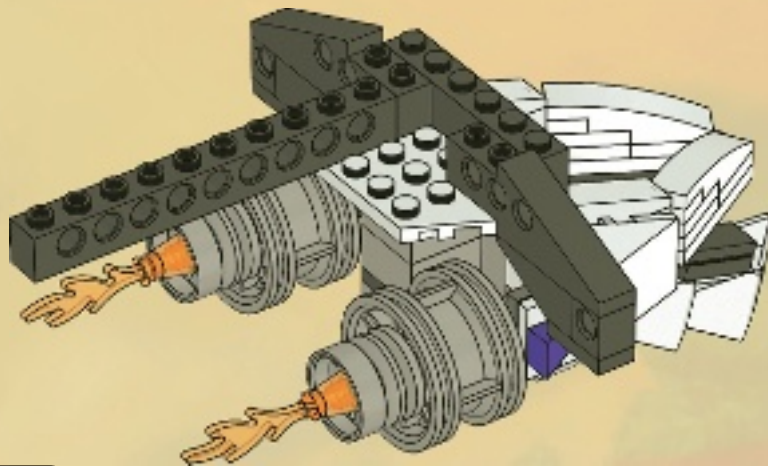

25

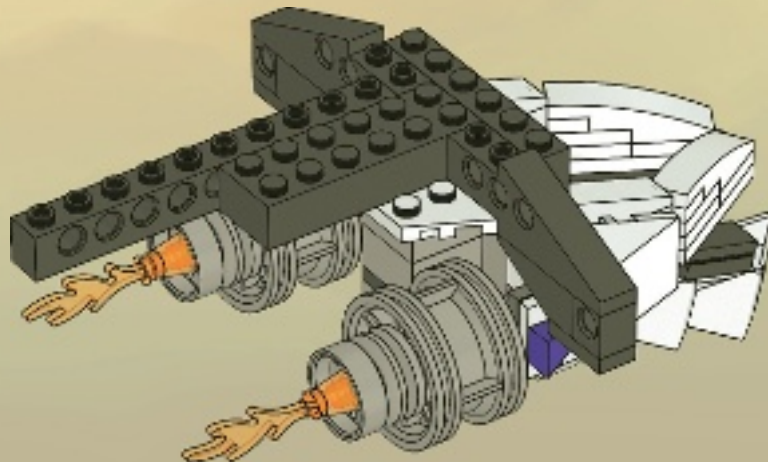



26

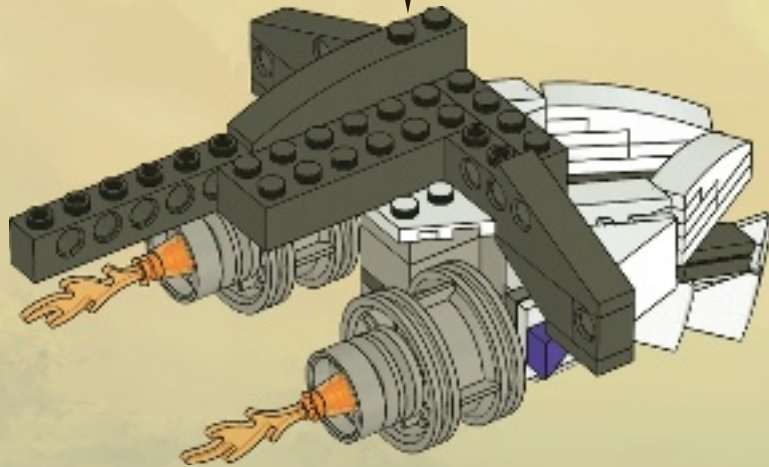
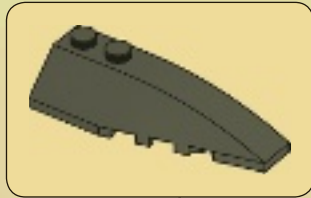





1x



2x

# 27

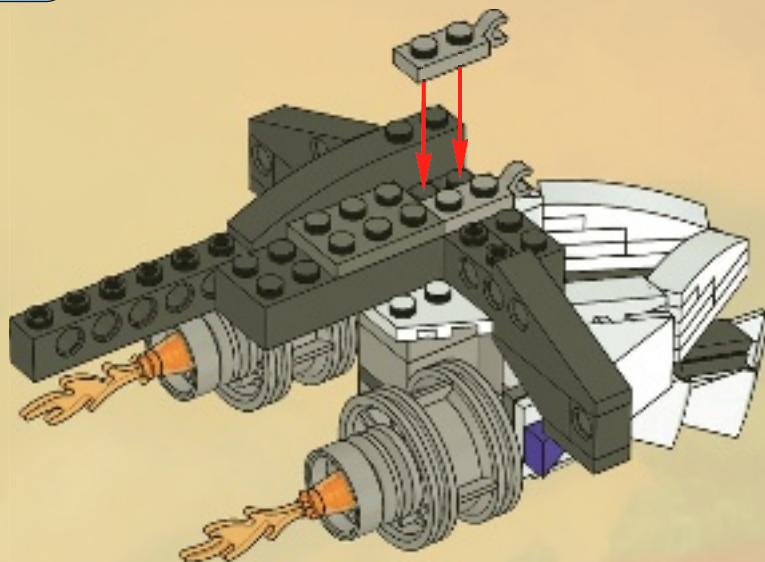

1x

# 28

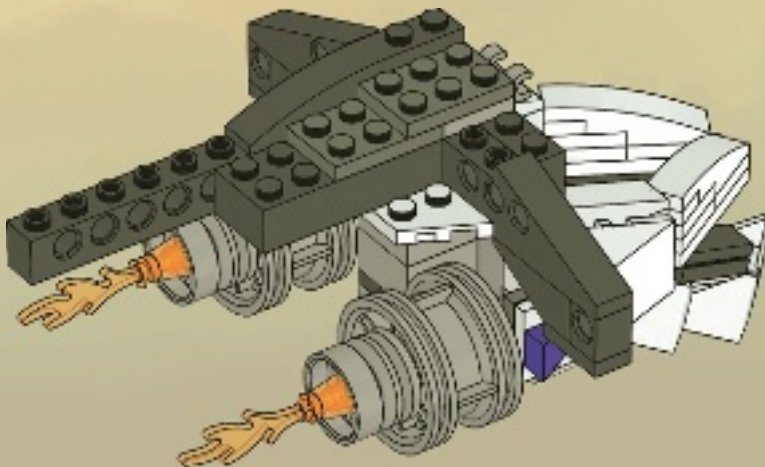



1x



2x

# 29

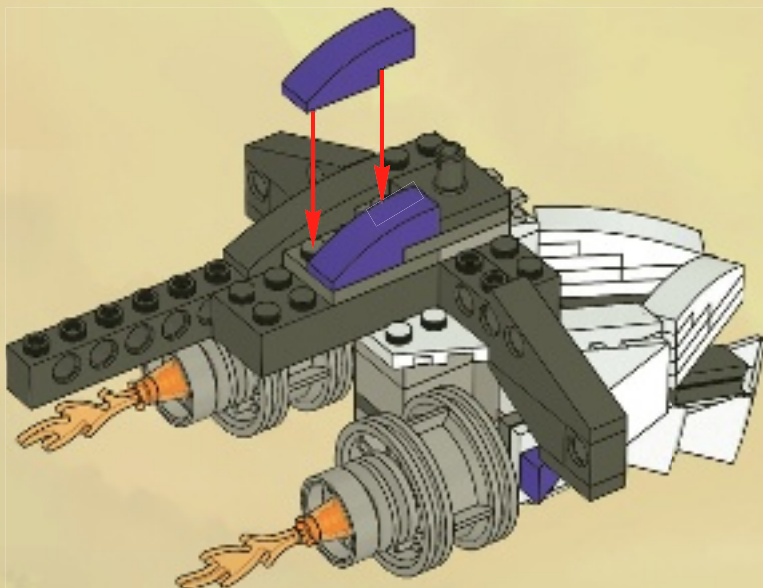



1x



1x

# 30

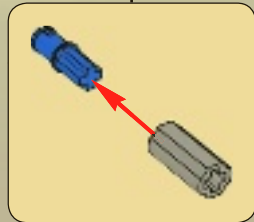
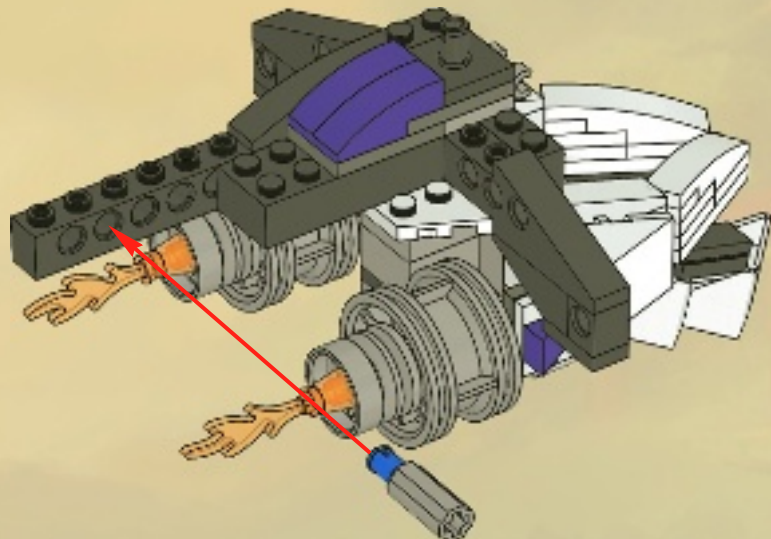

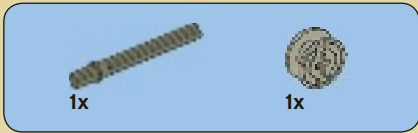

1



2



3

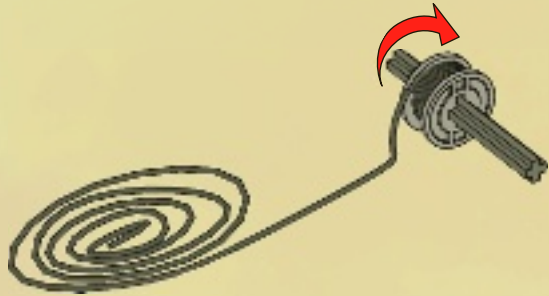

4





5

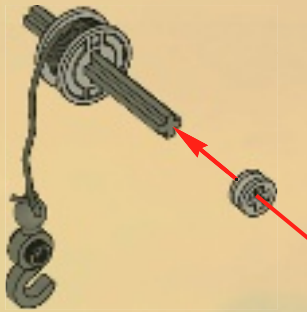

31

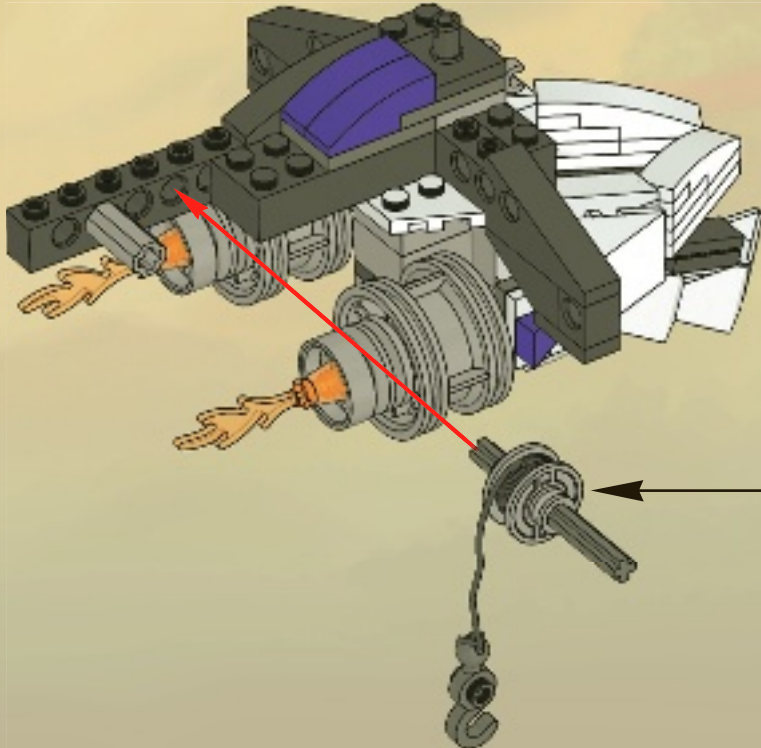



32

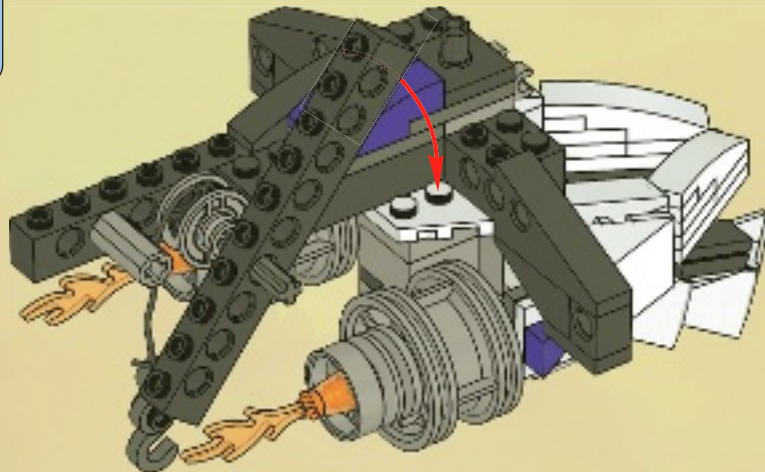

33

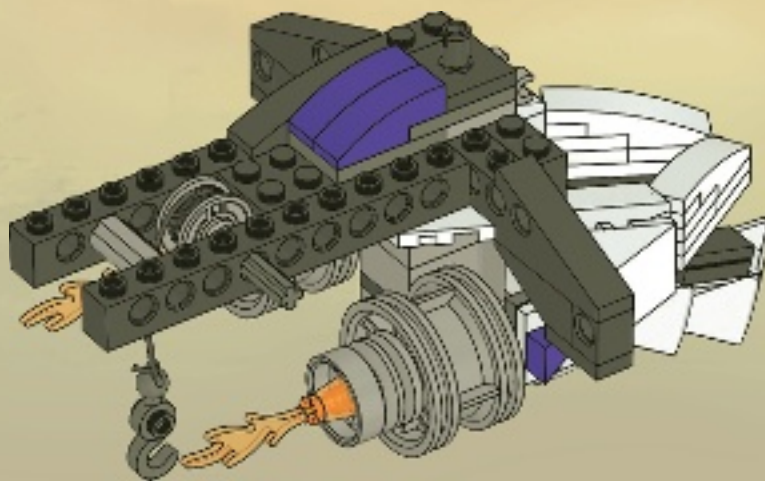



# 34

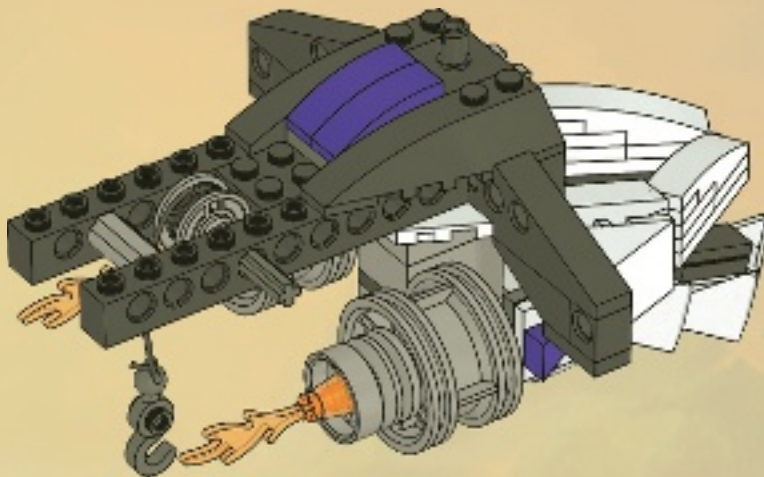

# 35

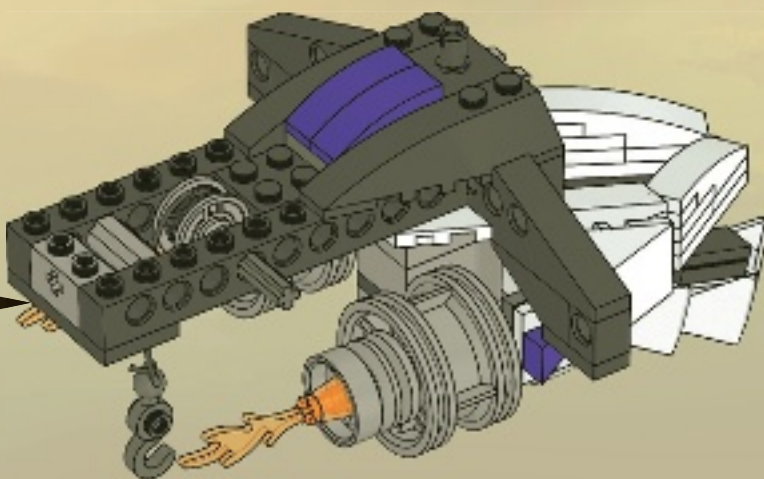
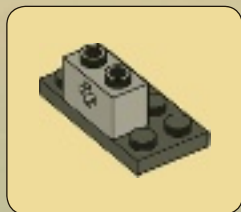



# 36

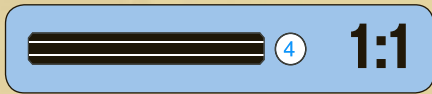
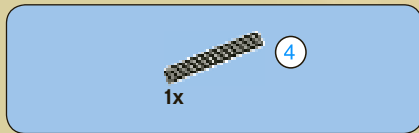
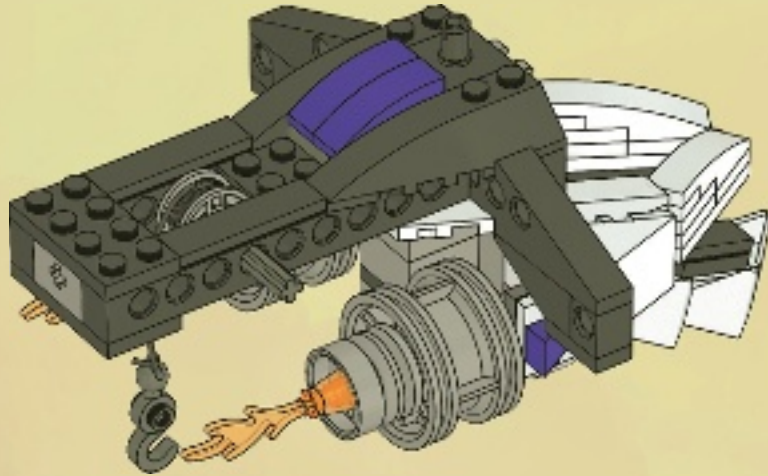

# 37

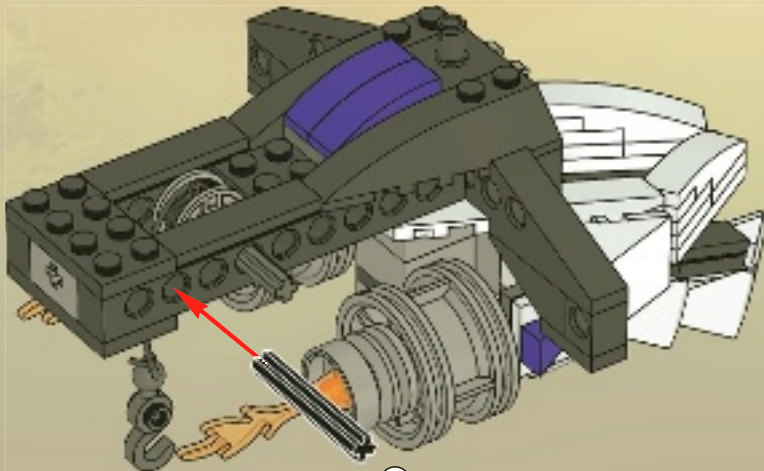

④





38

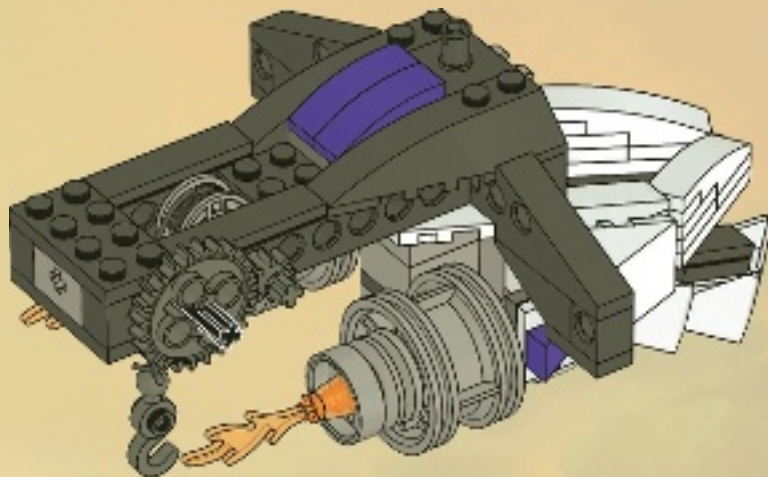

39

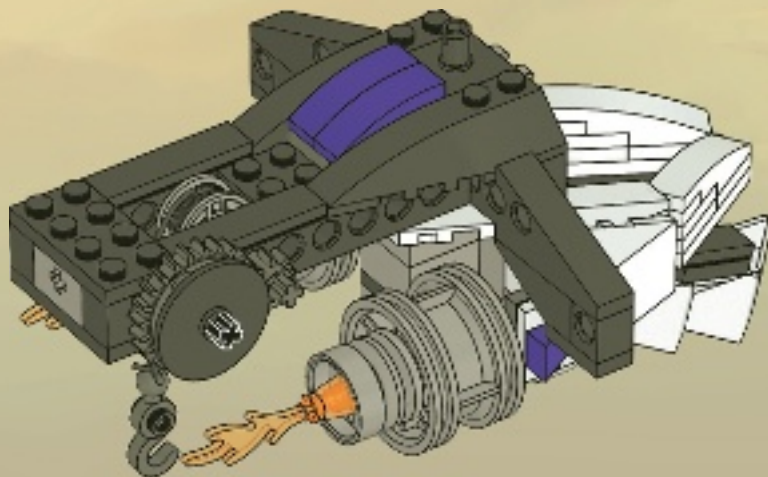

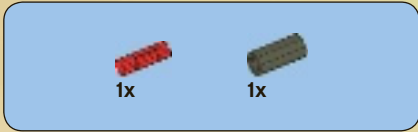

1

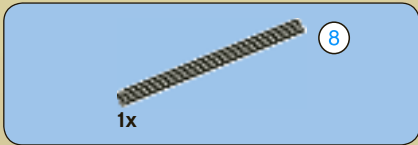
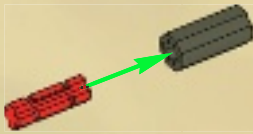

2



3

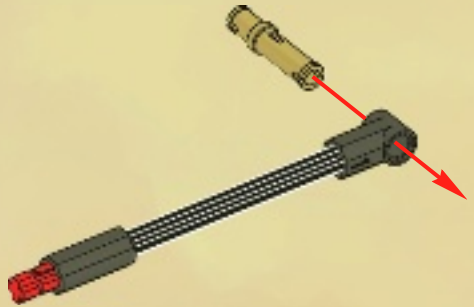

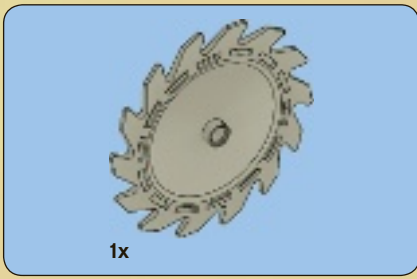

4

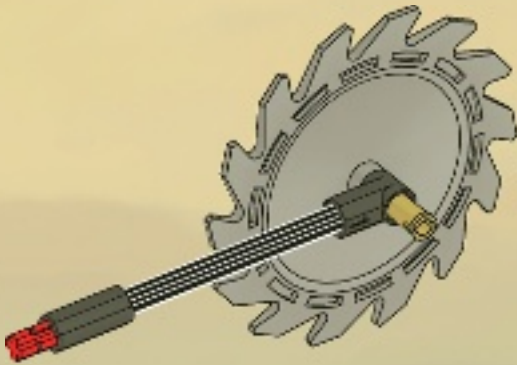

5

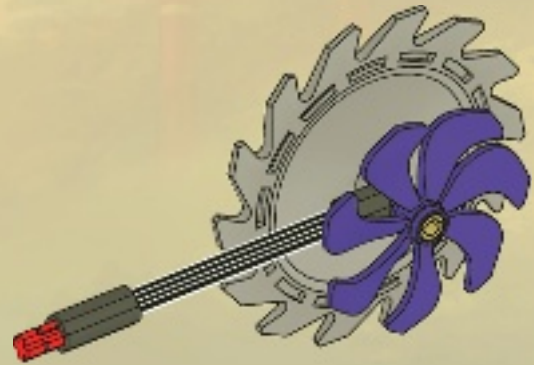

40

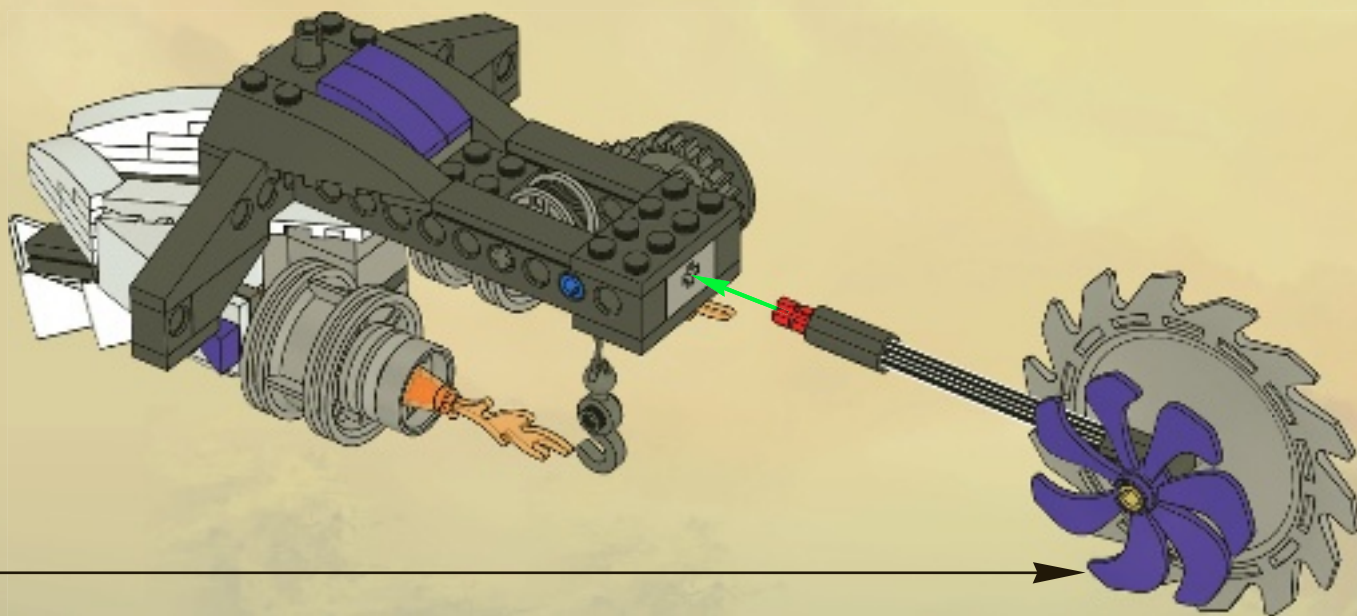
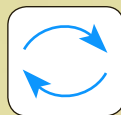



1

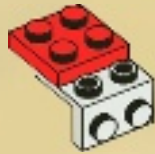

2



3

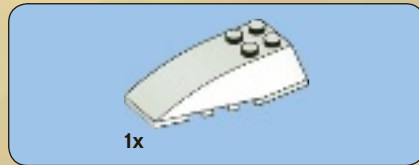
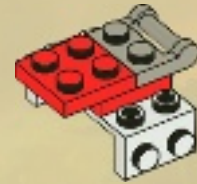

4

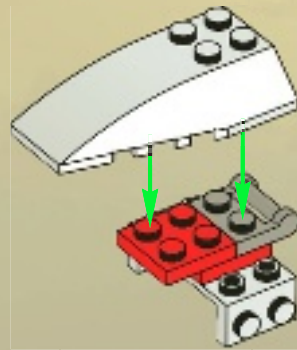



1x

5



1x

6

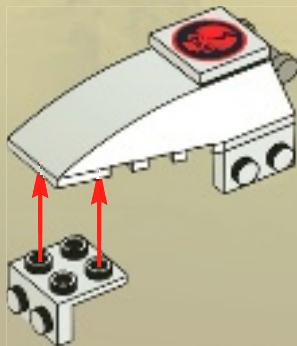

1x

7

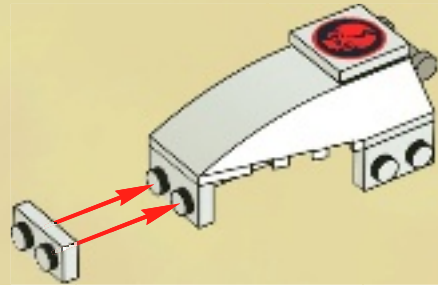

1x



2x

8

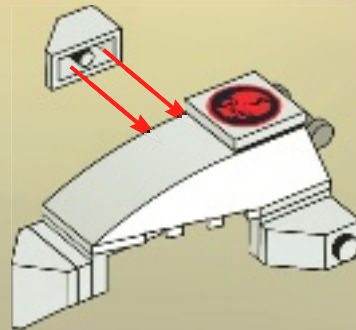

41

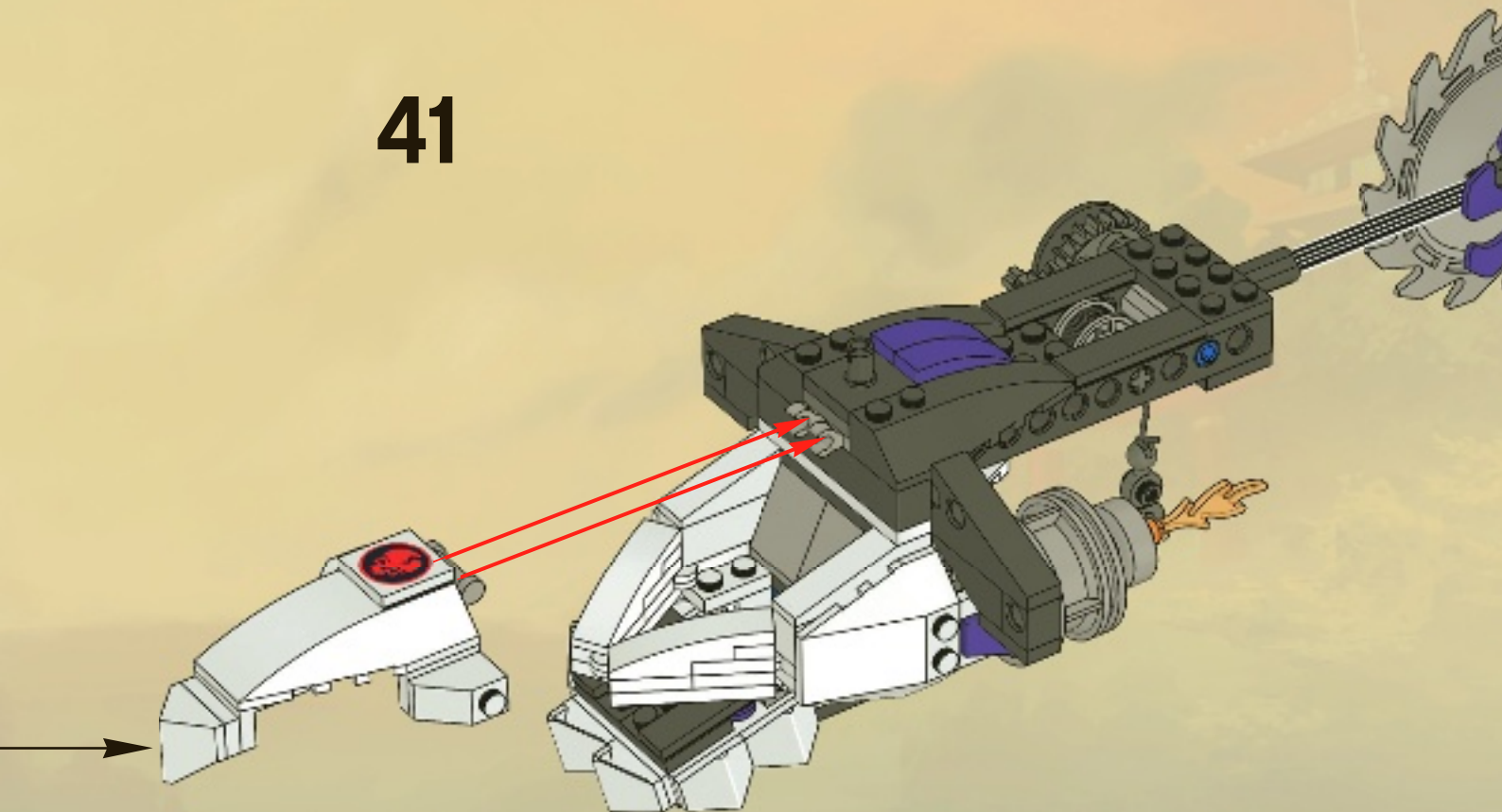

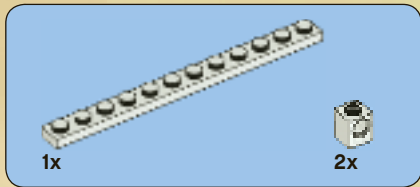
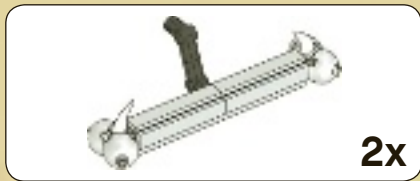

1

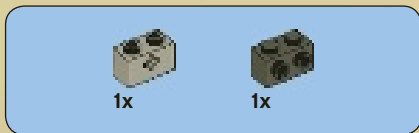
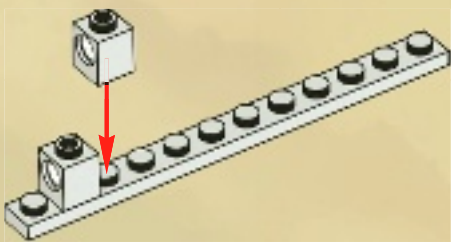

2

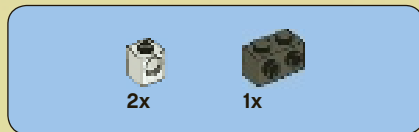
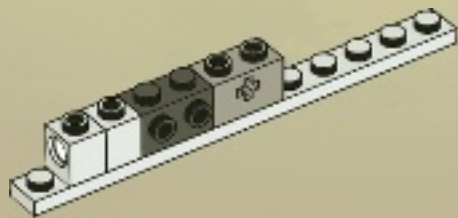

3

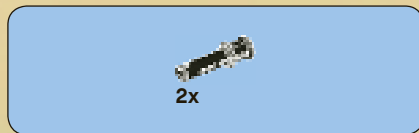
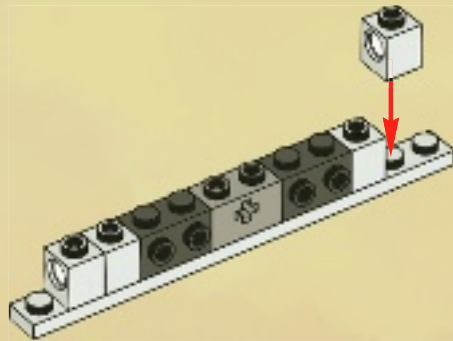

4

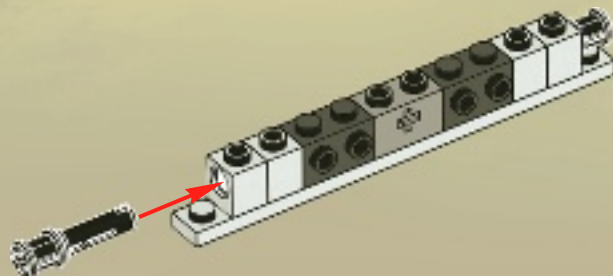



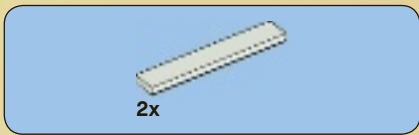

5

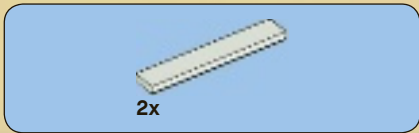
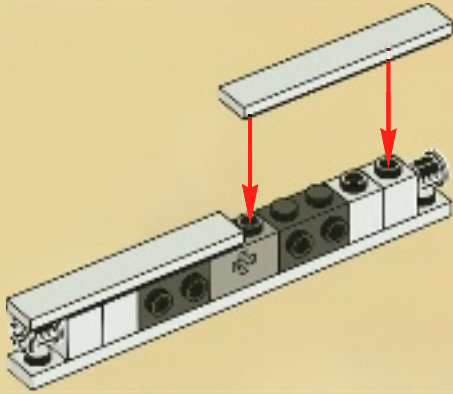

6

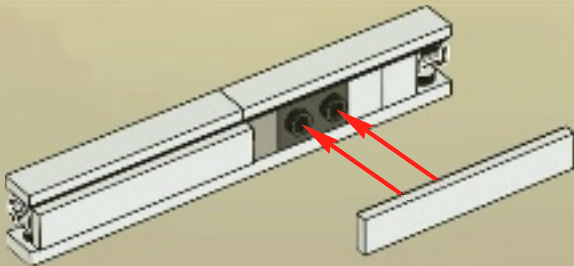

7

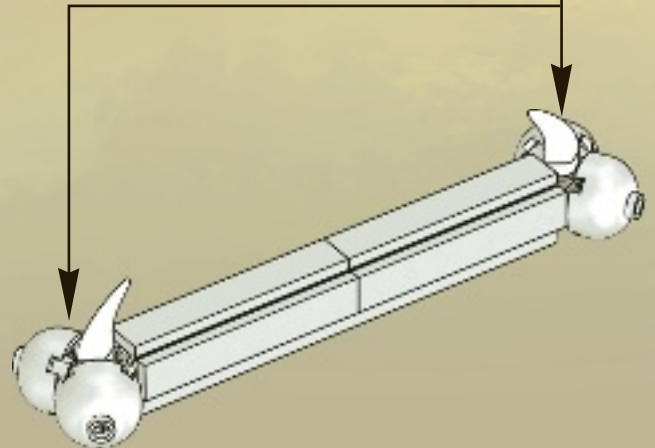
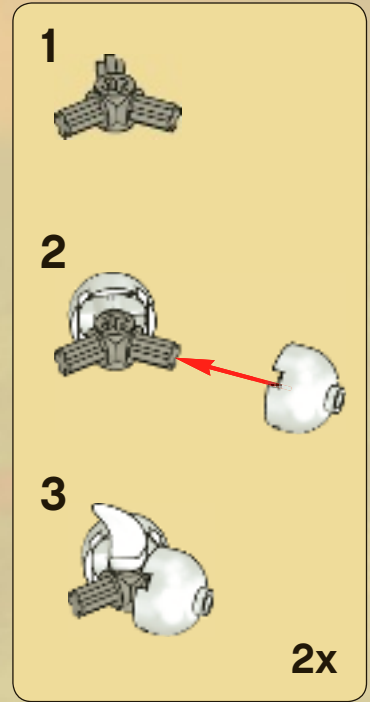



8

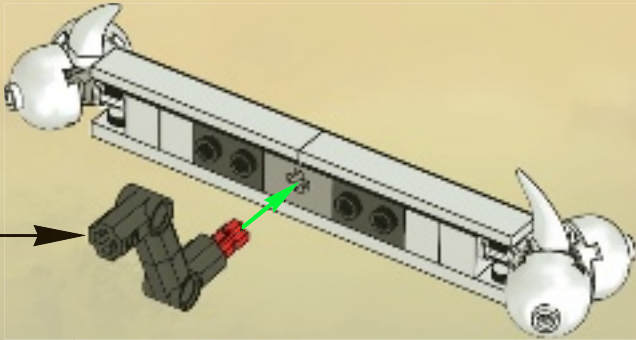
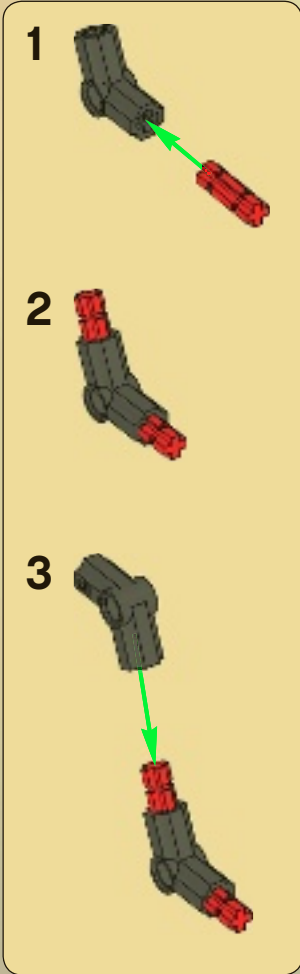

2x

42

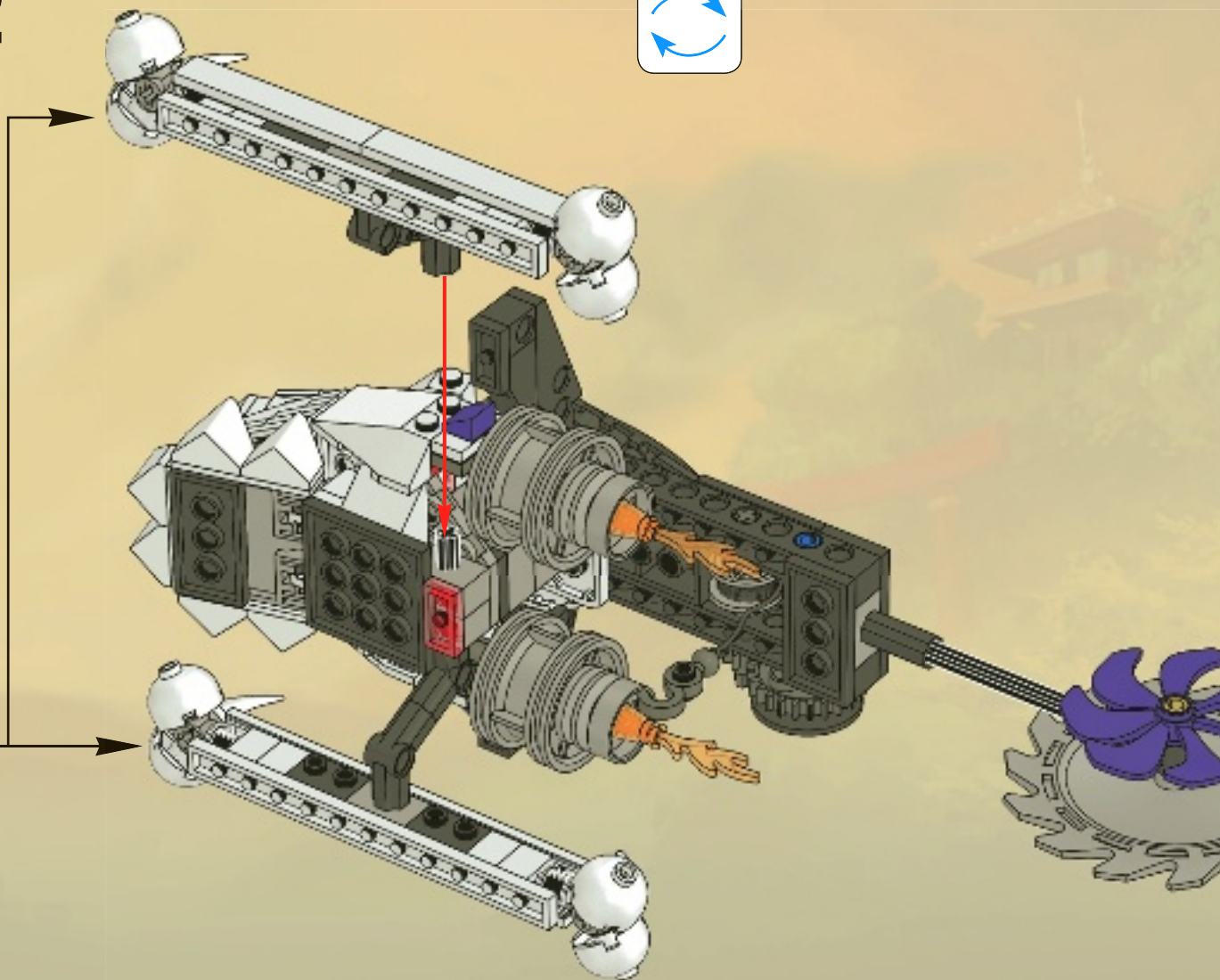
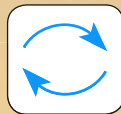



1

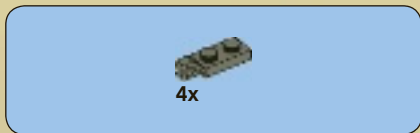

2

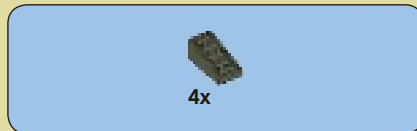
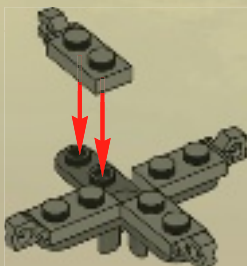

3

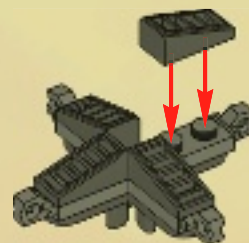

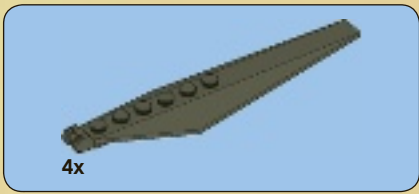

4

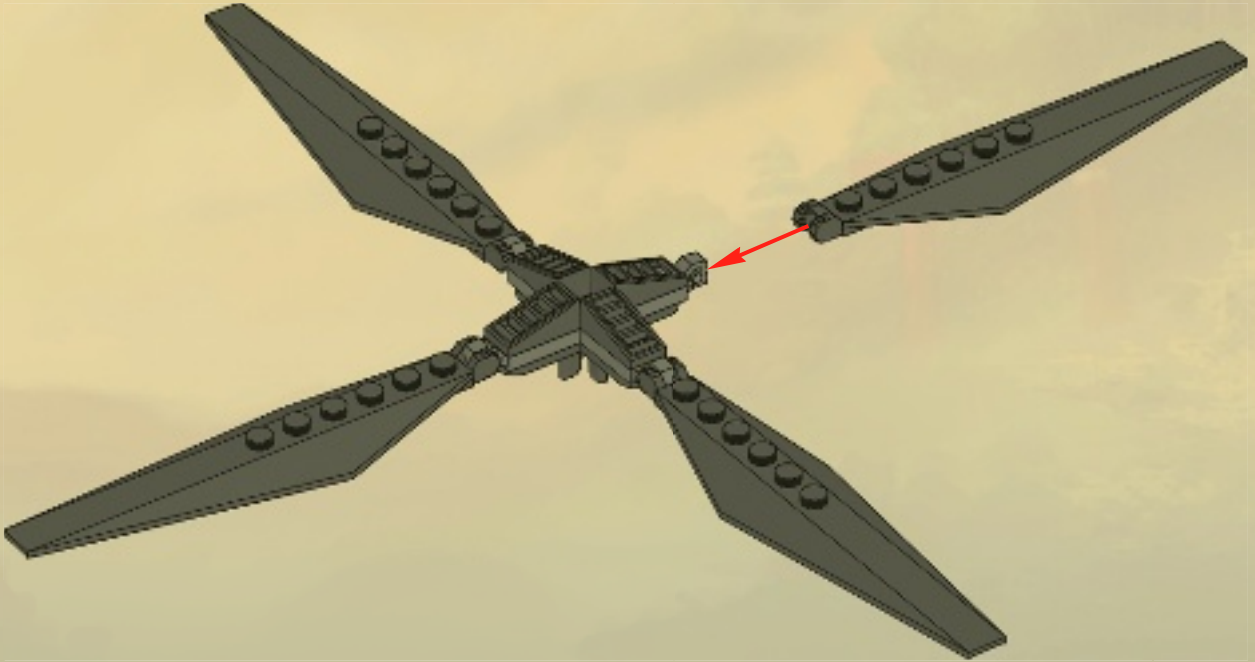

43

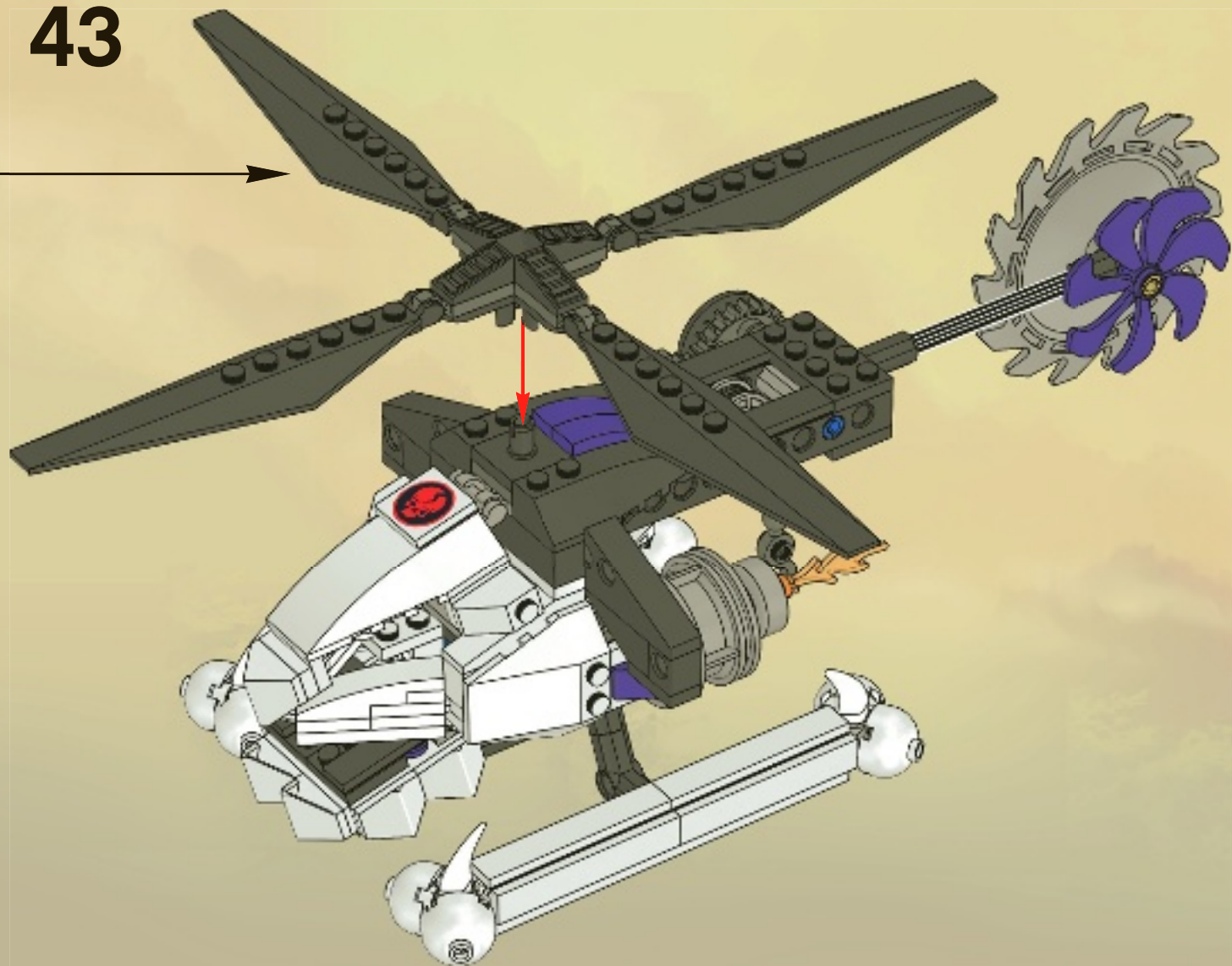



1

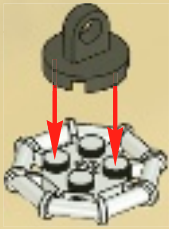

2

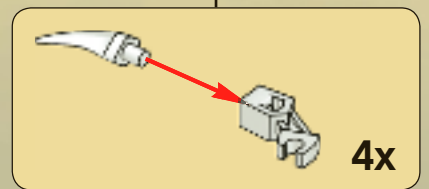
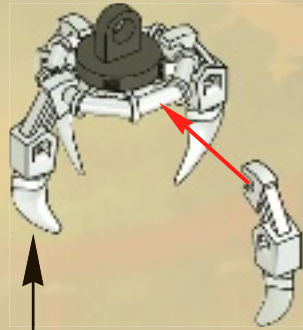

44

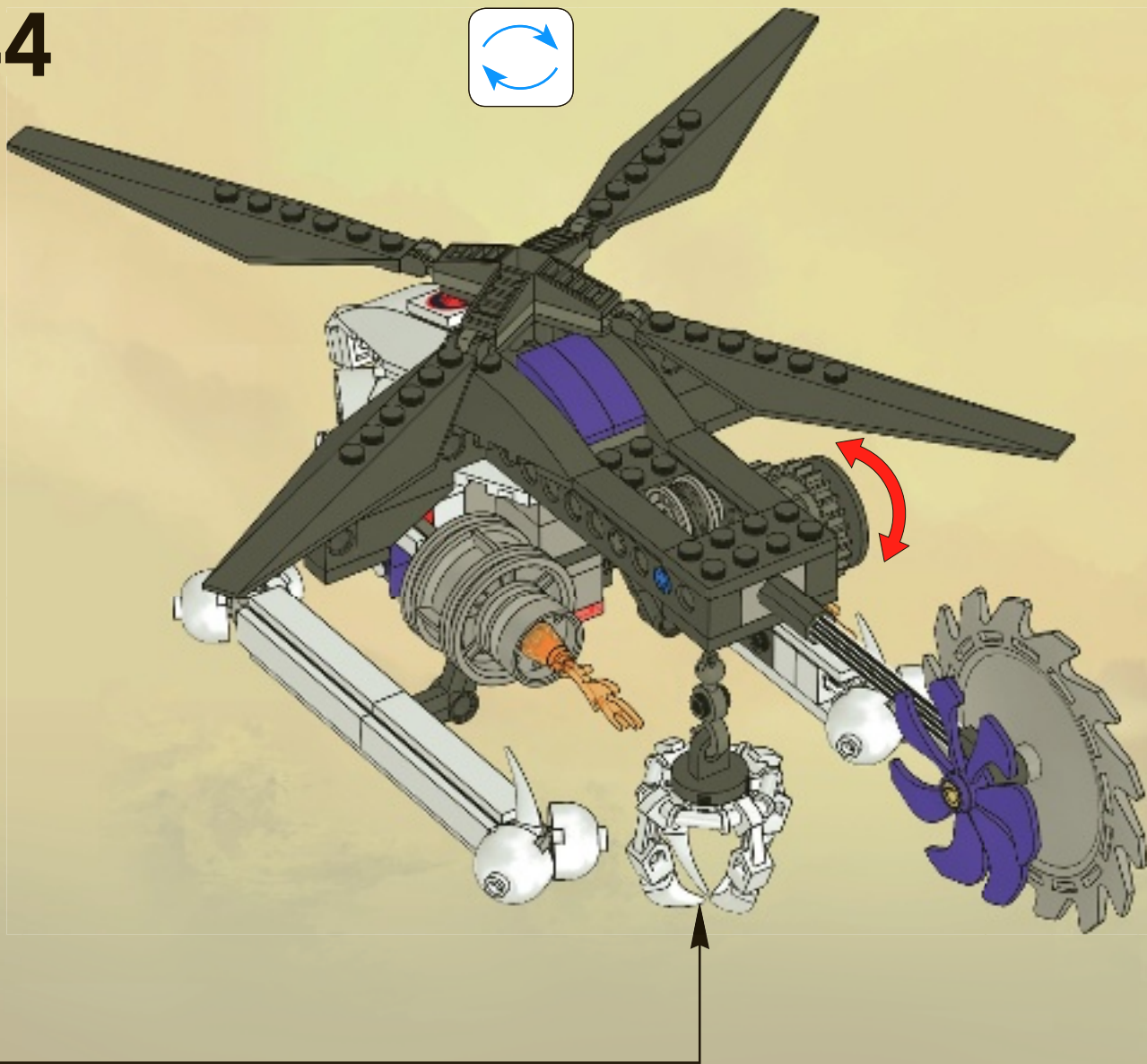



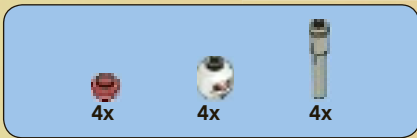

45

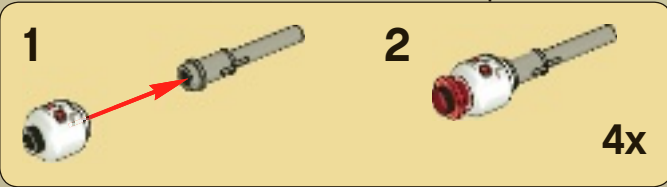
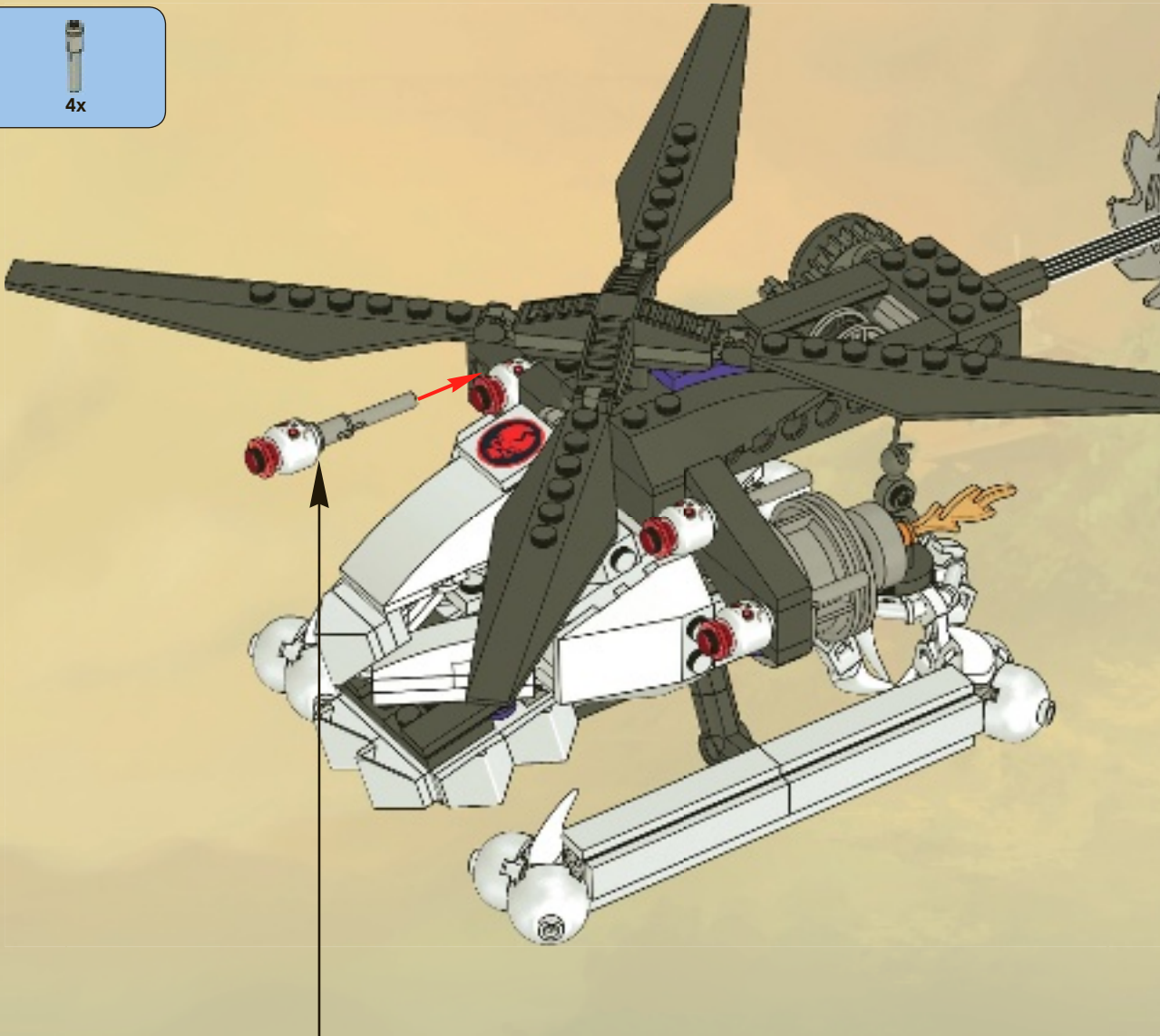





# NINJAGO

Masters of Spinjitzu



JAY  
2257 - 2506



KAI DX  
2507 - 2508 - 2254



ZANE  
2506 - 2507



COLE DX  
2170 - 2509



NYA  
2172 - 2507



SENSEI WU  
2255 - 2507



GARMADON  
2256 - 2506 - 2507



SAMUKAI  
2507



NUCKAL  
2173



FRAKJAW  
2257



KRUNCHA  
2174 - 2507



WYPLASH  
2175 - 2506 - 2509





# WIN!

Go to [www.LEGOsurvey.com/product](http://www.LEGOsurvey.com/product) to fill out a survey for a chance to win a cool LEGO® Product. No purchase necessary. Open to all residents where not prohibited.

 [www.LEGO.com](http://www.LEGO.com)



## [www.LEGOsurvey.com/product](http://www.LEGOsurvey.com/product)

### GEWINNE! WIN!

Nimm an der Umfrage auf [www.LEGOsurvey.com/product](http://www.LEGOsurvey.com/product) teil und hab die Chance ein cooles LEGO® Produkt zu gewinnen!  
Die Teilnahme am Gewinnspiel führt zu keinerlei Kaufverpflichtungen. Teilnahme in allen nicht ausgeschlossenen Ländern möglich.

Ga naar [www.LEGOsurvey.com/product](http://www.LEGOsurvey.com/product), vul een enquêteformulier in en maak kans op een cool LEGO® product.  
Geen aankoopverplichting. Iedereen mag deelnemen, uitgezonderd ingezetenden van landen waar een enquêteverbod geldt.

### GAGNE! 当てよう!

Visite [www.LEGOsurvey.com/product](http://www.LEGOsurvey.com/product) pour répondre à un questionnaire et avoir une chance de gagner un produit LEGO® très cool!  
Aucune obligation d'achat. Ouvert à tous les résidents des pays autorisés.

[www.LEGOsurvey.com/product](http://www.LEGOsurvey.com/product) にアクセスして、アンケートにご記入ください。当選者にはレゴ®製品を差し上げます。  
お買い上げの必要はありません。  
禁止されていない限り、すべての皆様にご利用いただけます。