



Camaro Z/28
1969





We've got a mean streak.

Z/28 Camaro.

The '69 Z/28. So ominous it goes by its code name. Code name: 302. Standard equipment: mechan-

ical lifters, high-performance cam springs and heavy-duty shocks. New for '69 are special white lettered tires on 15 x 7-inch wide wheels and a Hurst shifter

for the 4-speed. To complete the setup, just add the new "Vette-type 4-wheel power disc brakes.

By now you know the mean streak isn't just painted on—it's built in. One more thing. People are

bound to ask what the Z stands for. Tell them "Zaps" Chevrolet. **Putting you first, keeps us first.**

EL COUPÉ DEPORTIVO

Asequibles, deportivos y elegantes, los pony cars revolucionaron la industria del automóvil cuando aparecieron a mediados de la década de 1960. Una nueva generación de conductores más jóvenes se sintió inmediatamente atraída por las aerodinámicas líneas de sus carrocerías, con largos capós y potentes motores. Aunque casi todos los fabricantes de automóviles presentarían su propia interpretación del pony car, pocos tendrían tanto éxito como Chevrolet con su emblemático Camaro.

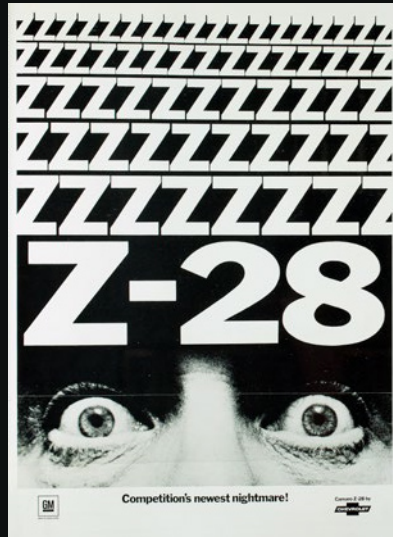

The skier's skier with the Camaro's Camaro.



There are skiers. And then there are skiers. Jean-Claude Killy is one of the latter.

The Camaro Z/28 is a special breed, too. It comes poised on a beefed-up suspension and special road-grabbing wide oval tires.

Under that striped hood is a tough 302 V8 that inhales through a big Holley 4-barrel and exhales through dual exhausts.

Z/28

Add four-on-the-floor with a Hurst shifter plus 4-wheel power disc brakes and you've got the closest thing to a 'Vette yet. Z/28. In our Sports Department. Almost as much fun as skiing.



Putting you first, keeps us first.

See Olympic Gold Medalist Jean-Claude Killy, *Sunday*, CBS-TV. Check your local TV listings.

69 CH-43 A
Ski February
February
1 page-4 colors
A P 7729-11 21 68-5



UN ÉXITO INDISCUTIBLE

El Chevrolet Camaro Z28 de segunda generación sigue siendo el mejor representante de los coches deportivos de gran potencia. Lanzado al mercado en 1969, el característico capó *power bulge* de inducción de aire y las líneas de velocidad modeladas en las defensas y las puertas garantizaban que fuera original y diferente de cualquier otro coche. Rehusó adoptar el diseño de otros vehículos de la época y, más de 50 años después, su aspecto sigue revistiendo frescura y audacia.



camaro

Camaro

CAMARO



1967 – 1969

1970 – 1981

1982 – 1992

UN EMBLEMA DEL AUTOMOVILISMO

Si bien han pasado 55 años desde el lanzamiento del primer Chevrolet Camaro, la célebre marca está más viva y vigente que nunca, con la sexta generación del inconfundible vehículo actualmente en producción. La marca y el nombre siguen fascinando a múltiples generaciones, cuentan con el aprecio de los mayores entusiastas de los coches deportivos de gran potencia y aparecen en innumerables videojuegos, programas de televisión y películas como parte fundamental de la cultura pop.

CAMARO

CAMARO



1993 - 2002

2010 - 2015

2016 -



IMPRESIONES DEL EQUIPO DE DISEÑO

"Crecí sintiendo una profunda pasión por los automóviles y ya desde muy pequeño hojeara revistas de coches deportivos, así que poder trabajar en este modelo LEGO® con verdaderos diseñadores de Chevrolet fue un sueño hecho realidad. Queríamos acertar con el estilo y el porte en general, pero también era importante incluir funciones y detalles divertidos aunque esenciales; por ejemplo, haciendo que las puertas funcionaran e incluyendo el mecanismo de dirección. También fue estupendo poder ofrecer algunas opciones de personalización tal como hacía el Camaro original en su día".

Sven Franic, diseñador de LEGO®





TU MODELO. TUS PREFERENCIAS.

Una de las características más populares del Camaro original era su amplia gama de opciones de personalización y motores de alto rendimiento. Del mismo modo, te ofrecemos la oportunidad de diseñar tu propia versión LEGO® del coche: ¿debería ser un coupé de techo rígido o un fantástico descapotable? ¿Y las franjas? ¿Clásicas en blanco, en un discreto gris o en un llamativo rojo? También encontrarás cubiertas opcionales para los faros delanteros y dos placas de matrícula para elegir.



No es posible construir simultáneamente los tres modelos.

Descarga las instrucciones de estos modelos alternativos en:
[LEGO.com/buildinginstructions](https://www.lego.com/buildinginstructions)



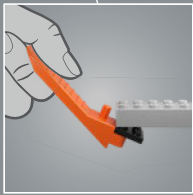
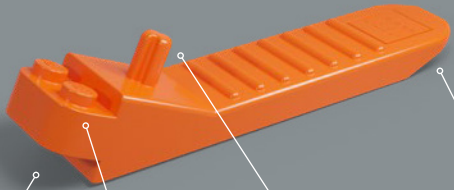
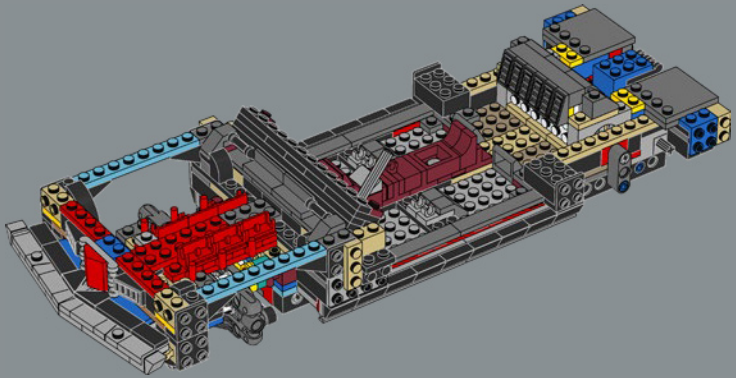
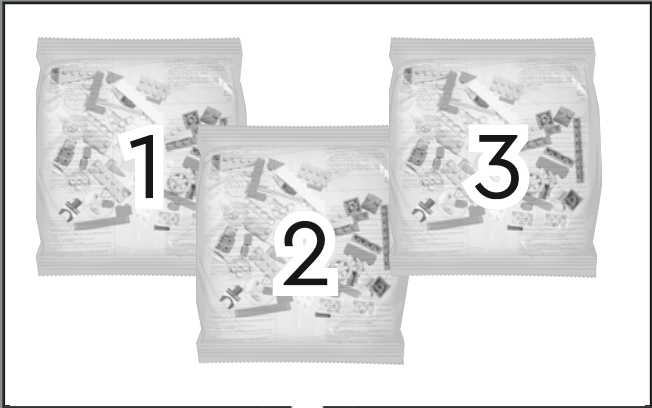

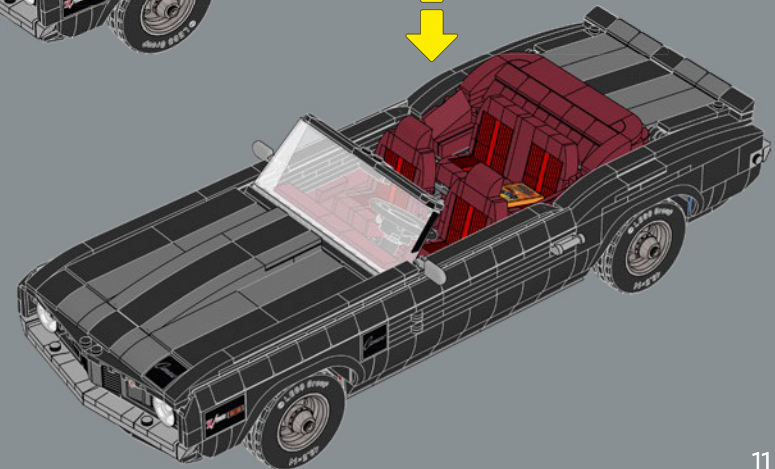
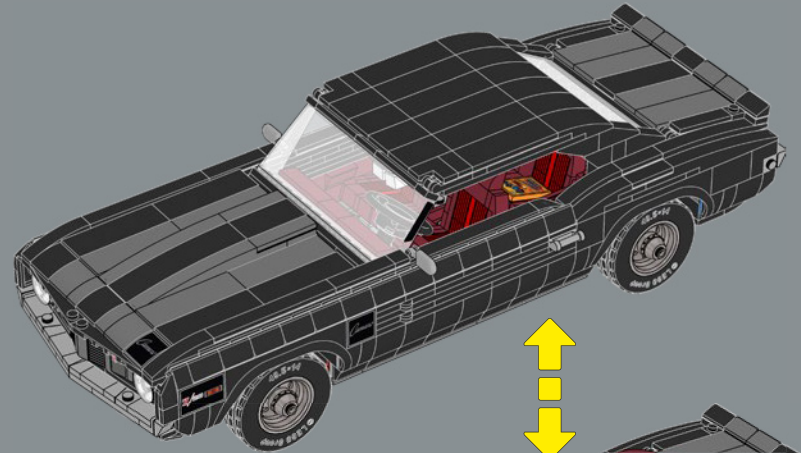
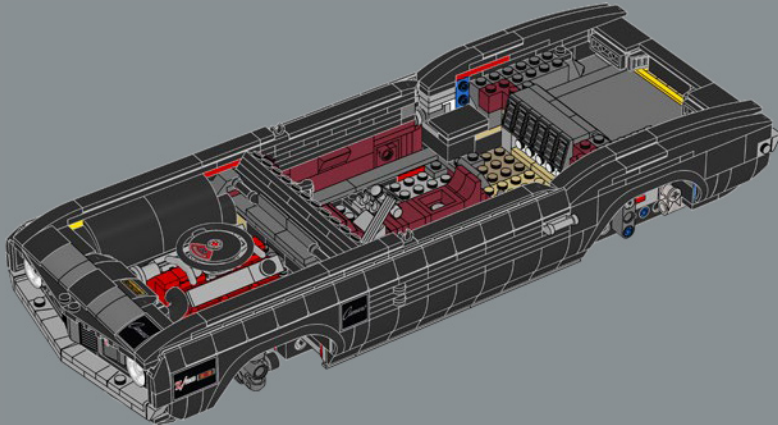
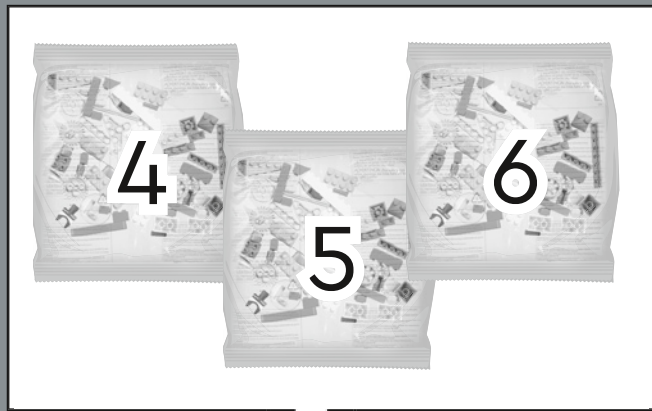

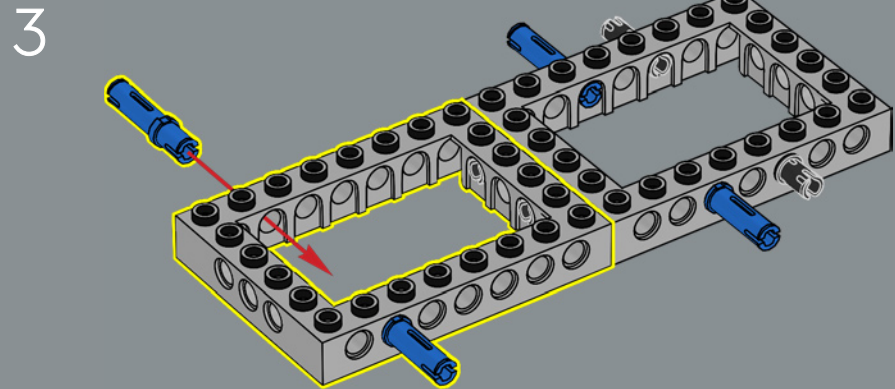
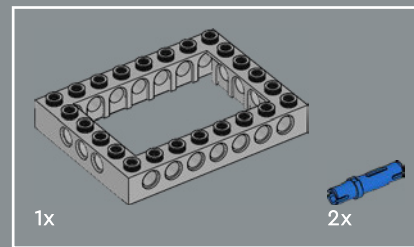
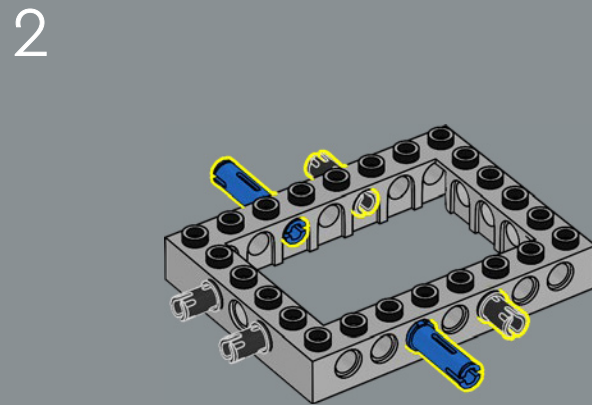
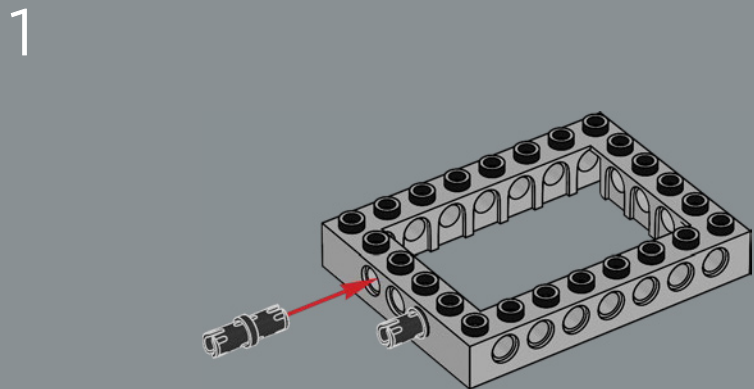
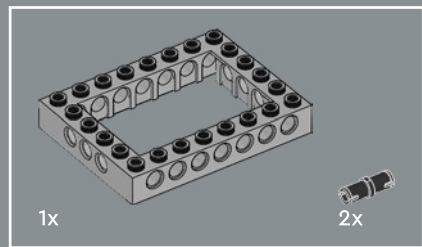

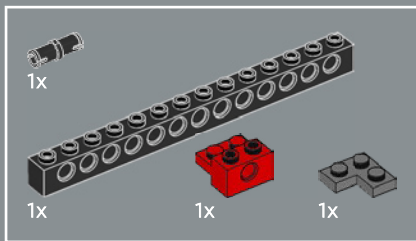

4

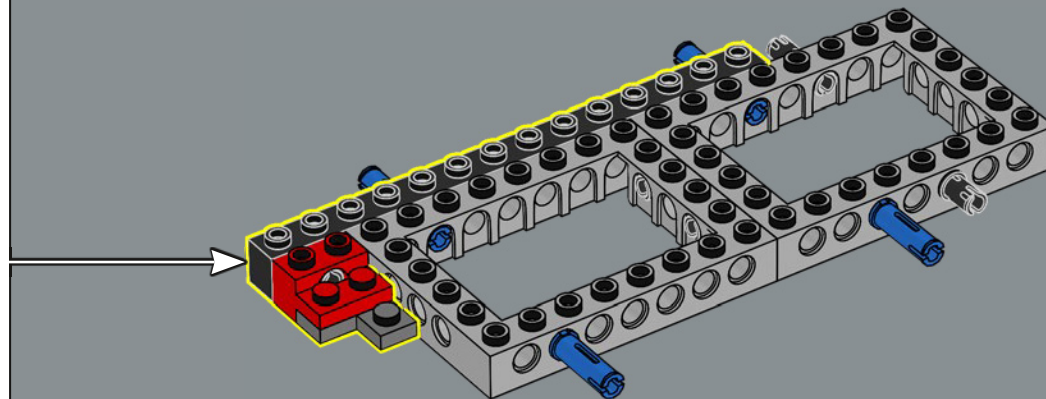
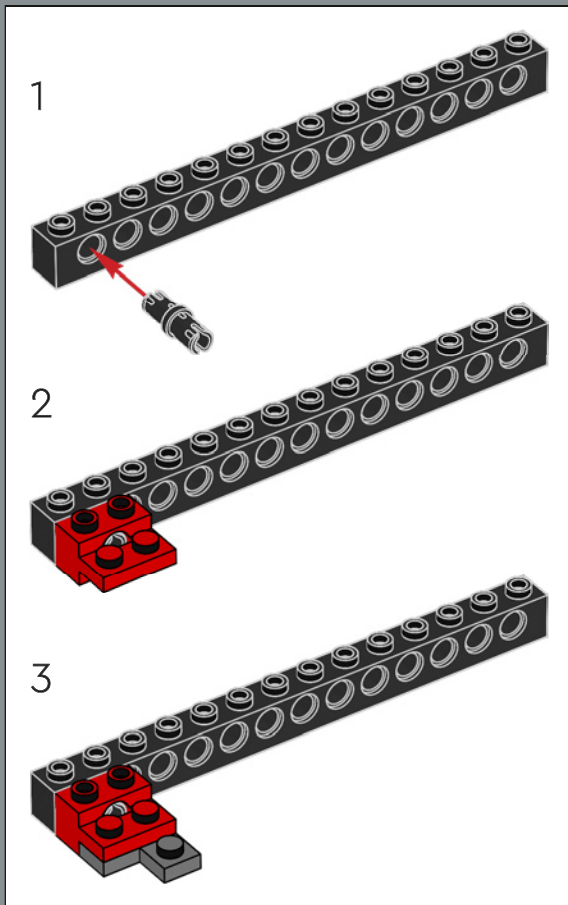

El nombre *Camaro* encaja en la tradición de Chevrolet de bautizar sus modelos comenzando por la letra C (Corvair, Corvette, Chevelle, etc.).

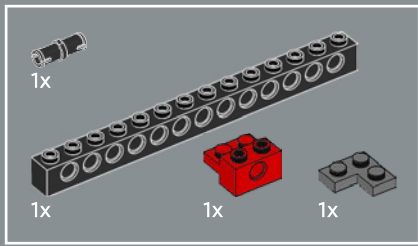

5

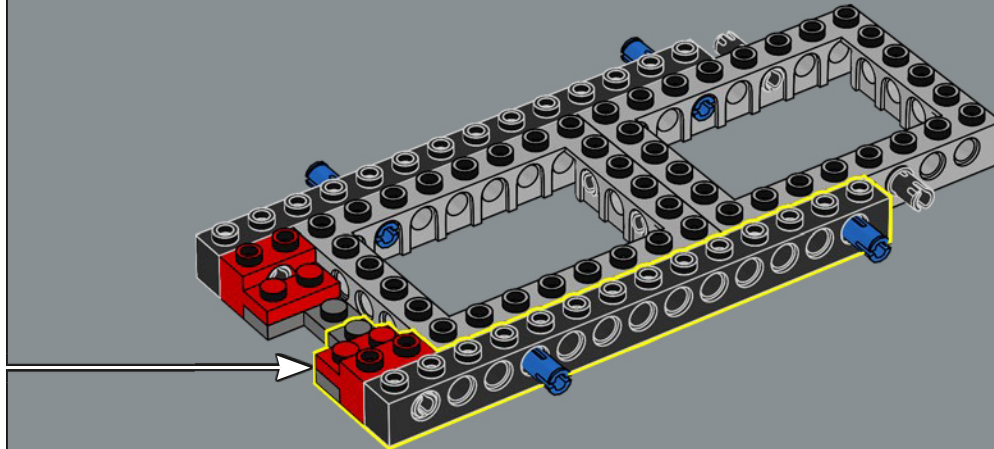
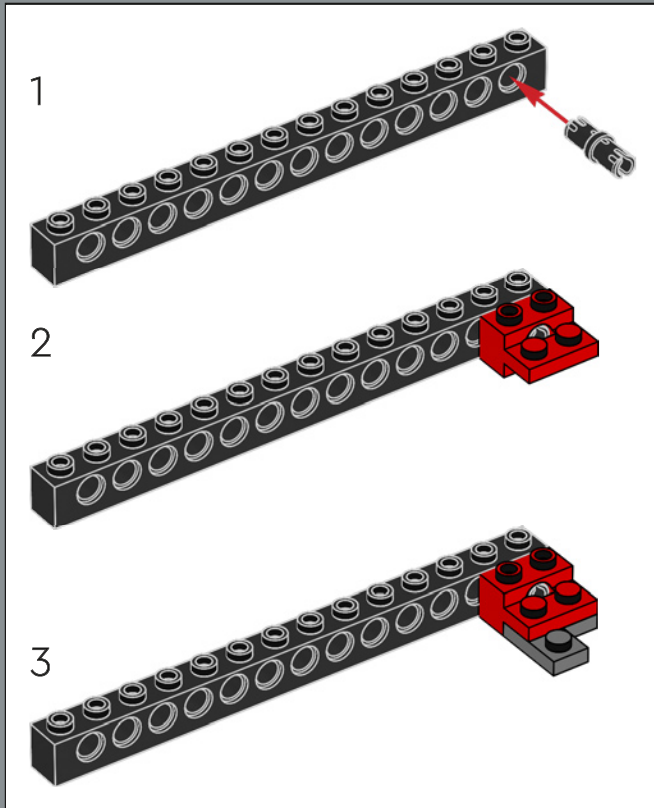

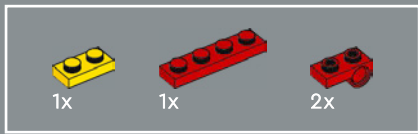

6

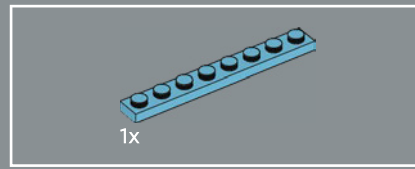
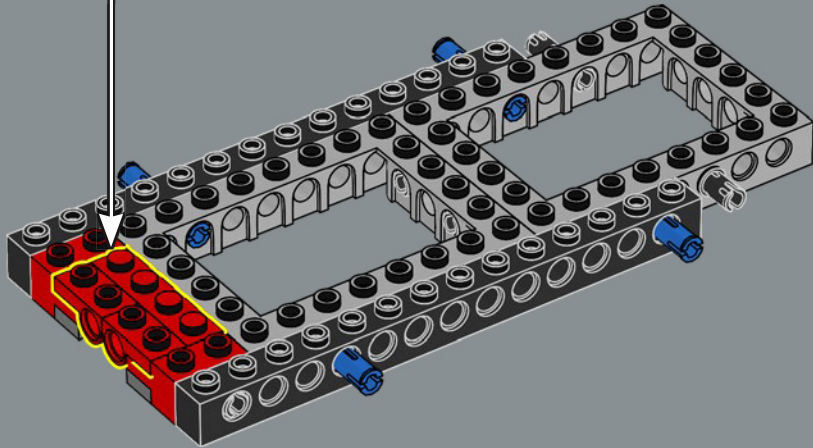
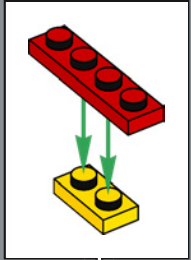

7

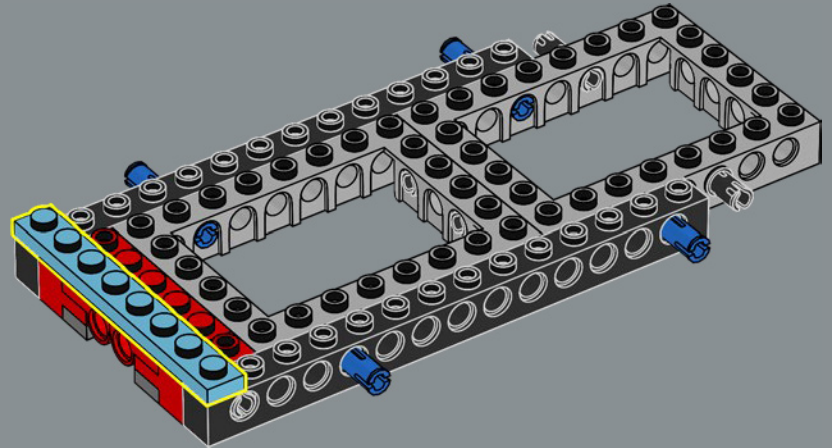

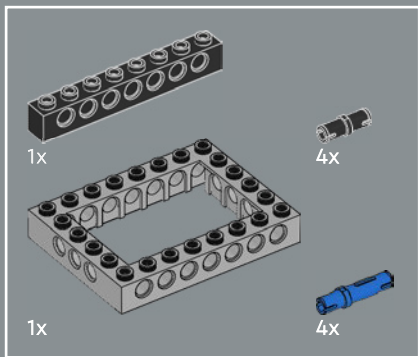

8

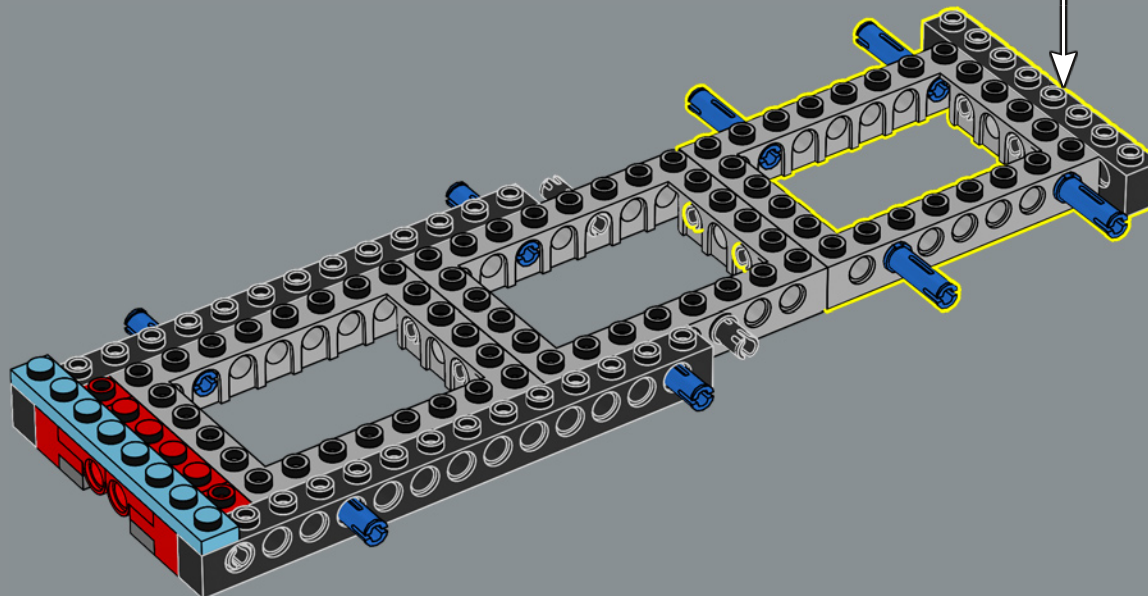
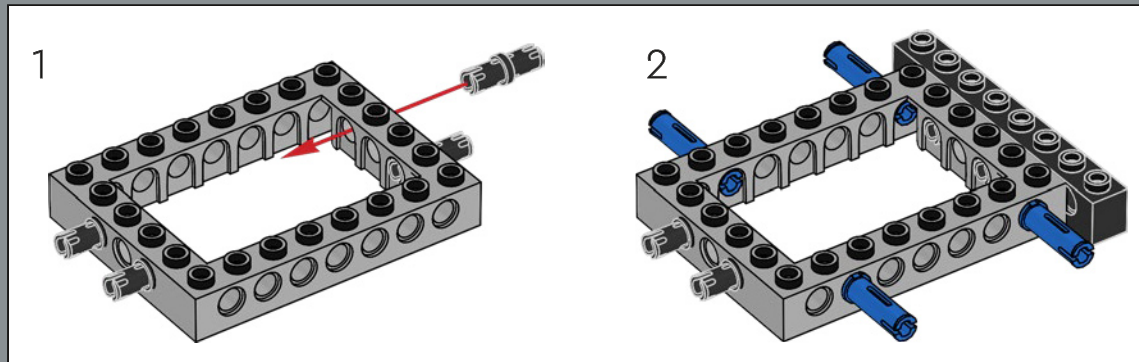

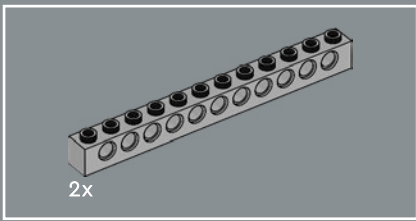

9

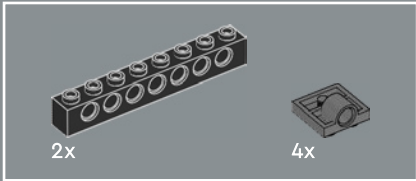
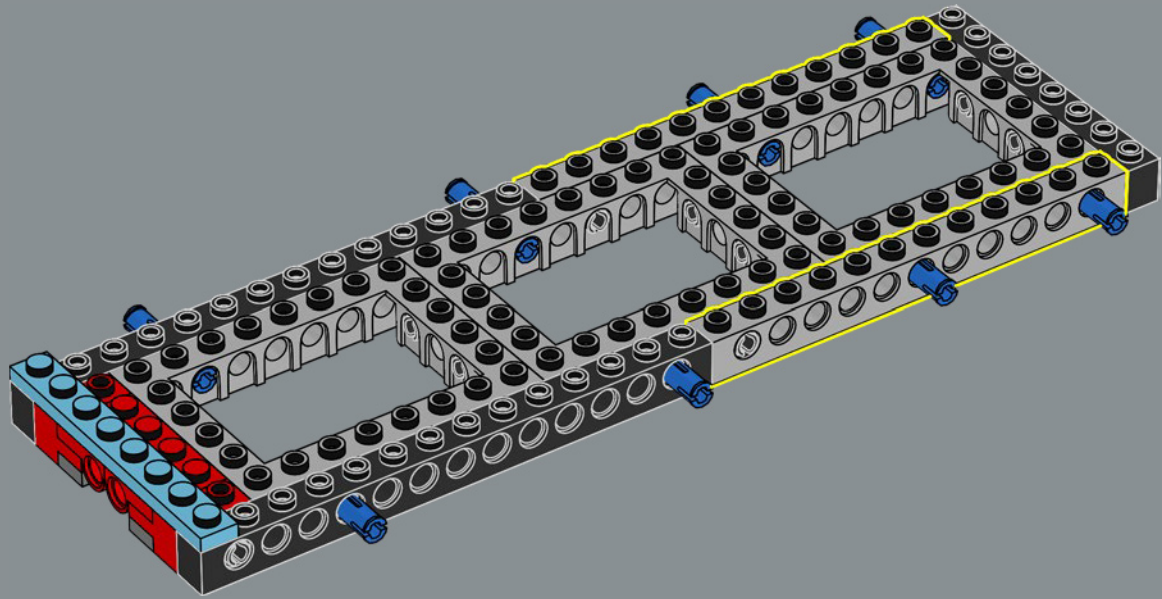

10

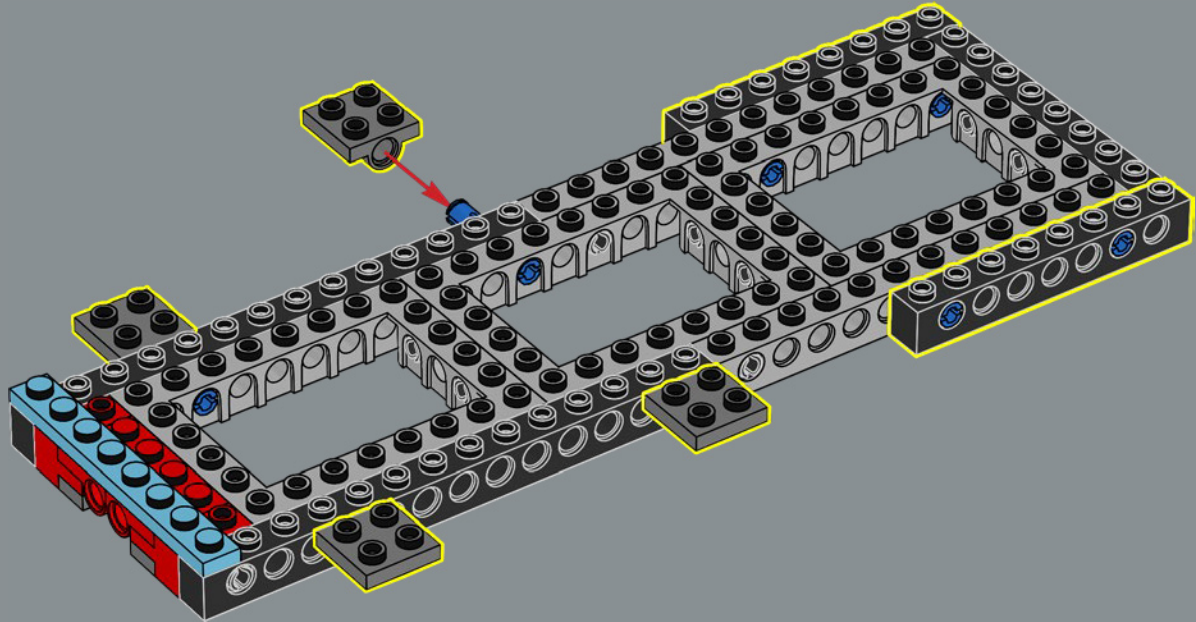

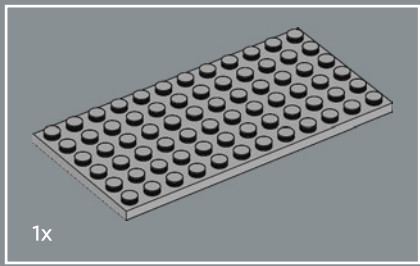

1x

11

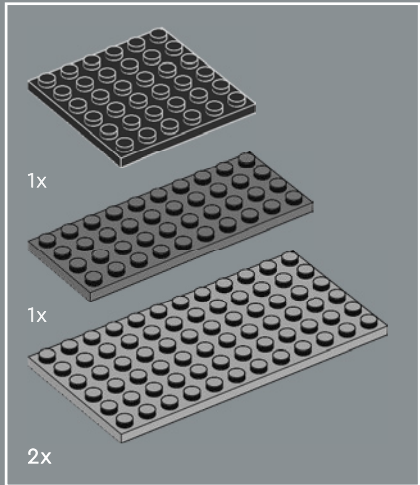
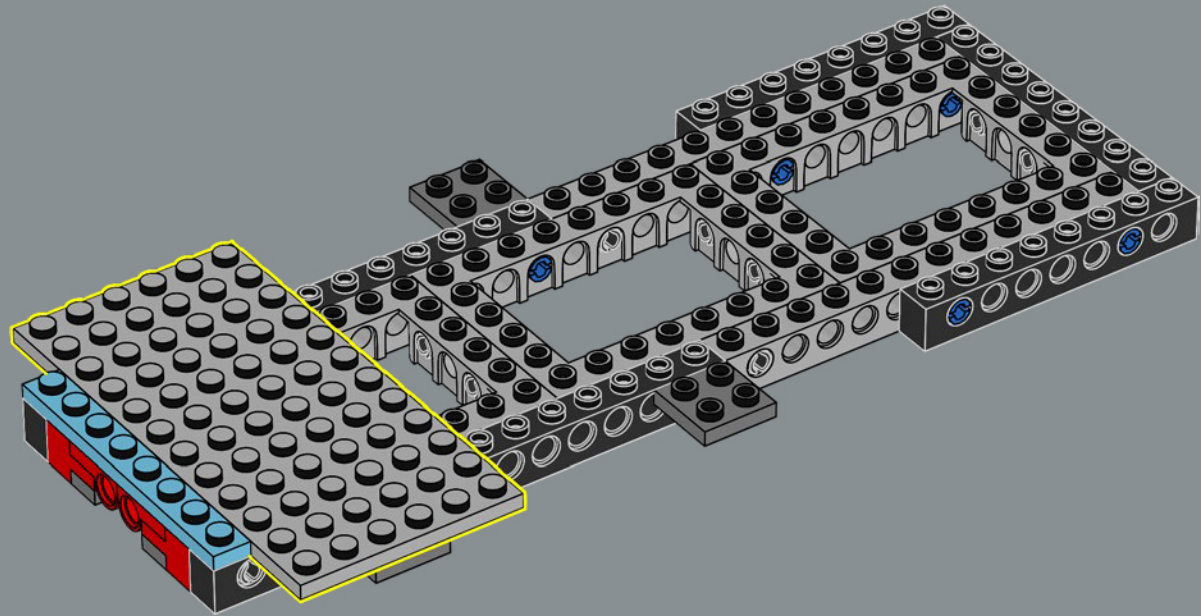

1x

1x

2x

12

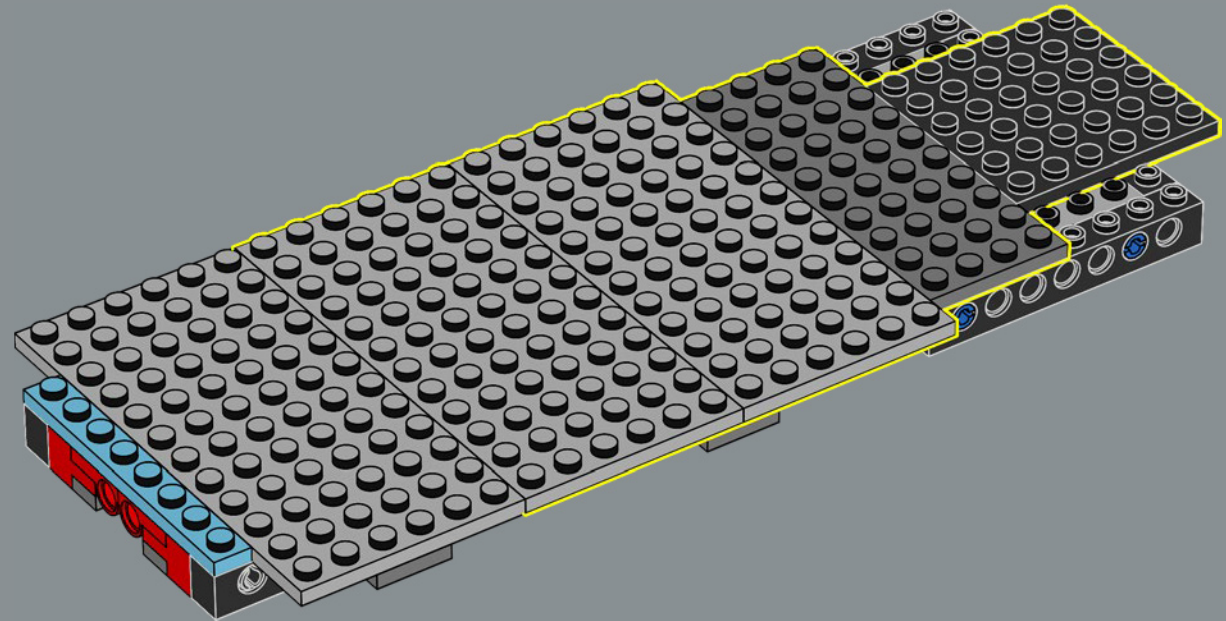



13

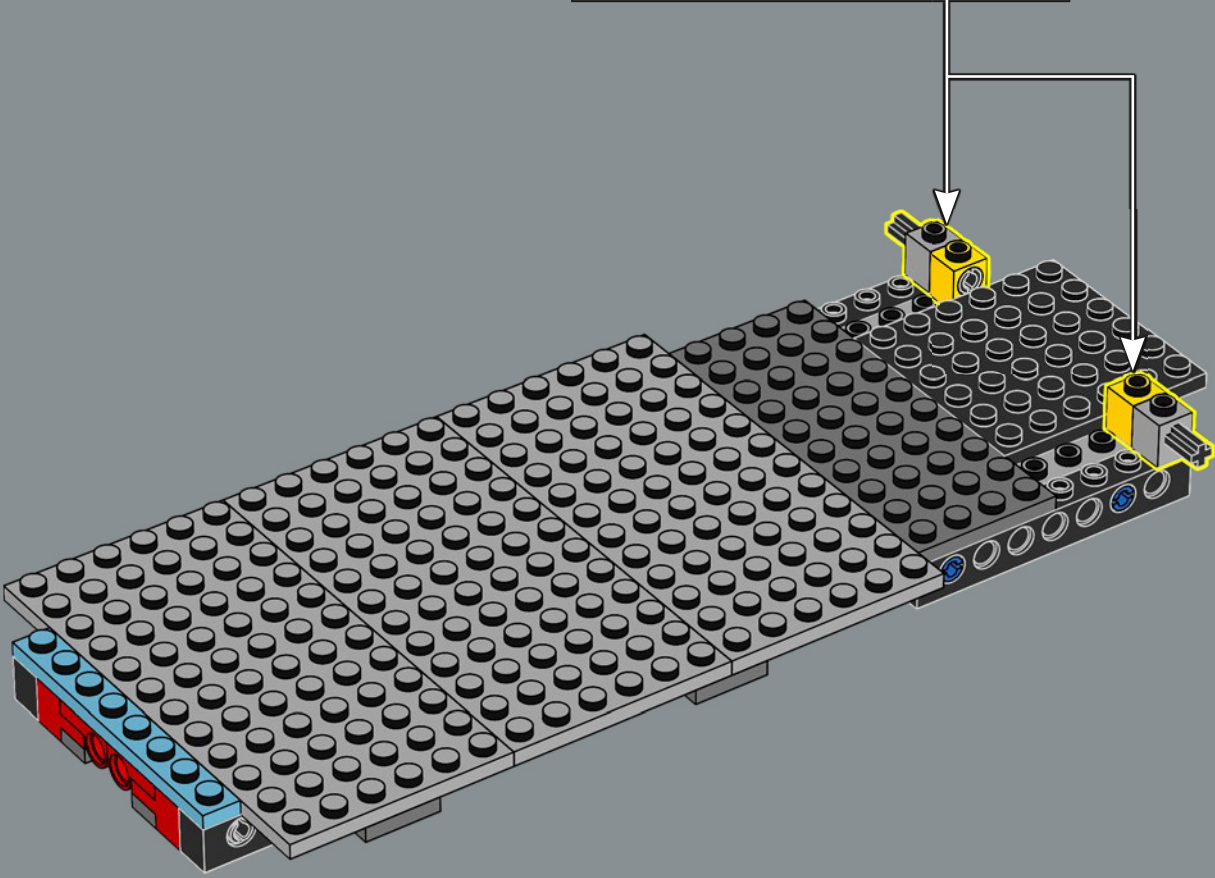
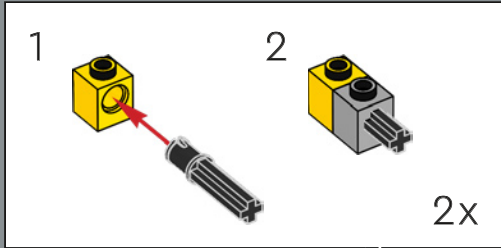

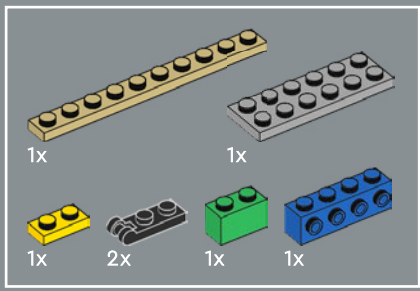

14

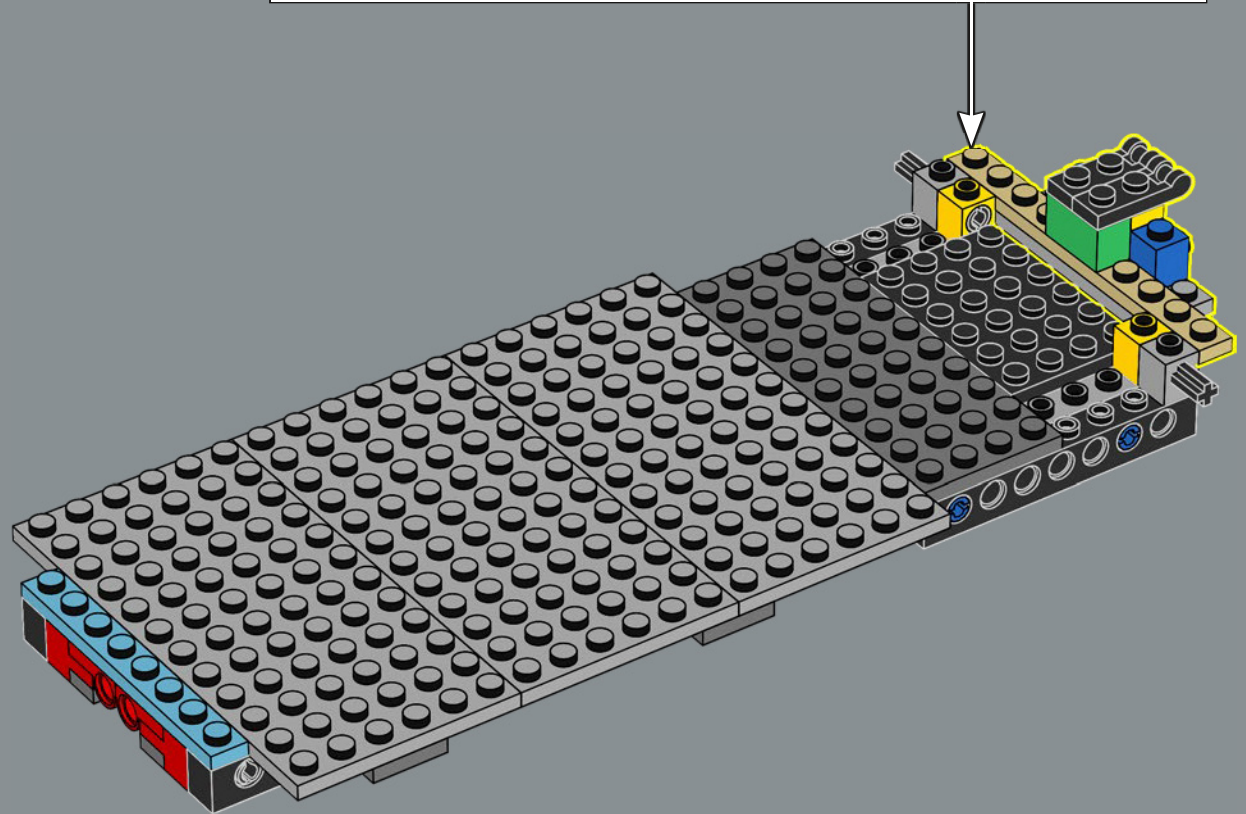
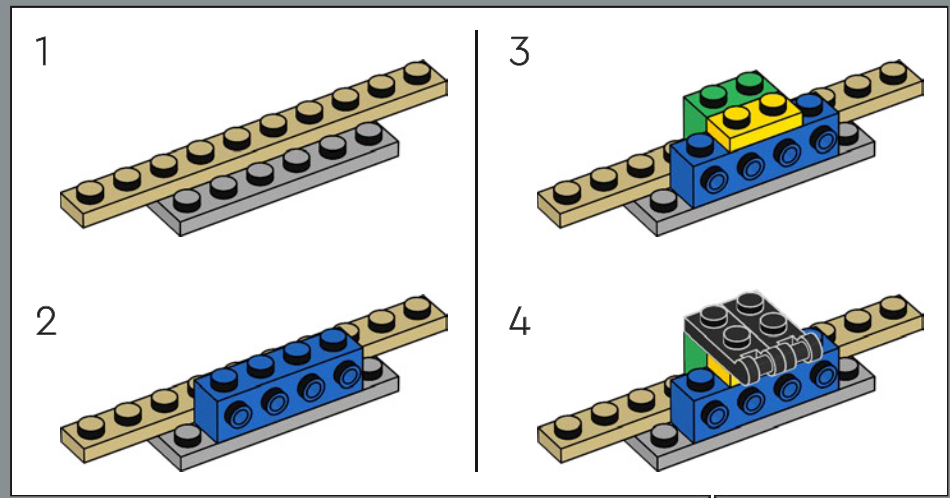

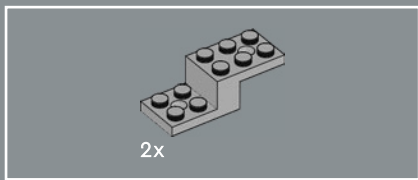

15

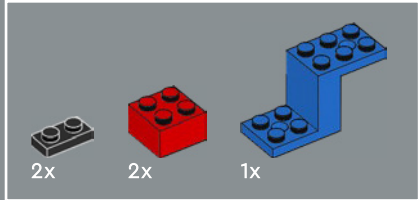
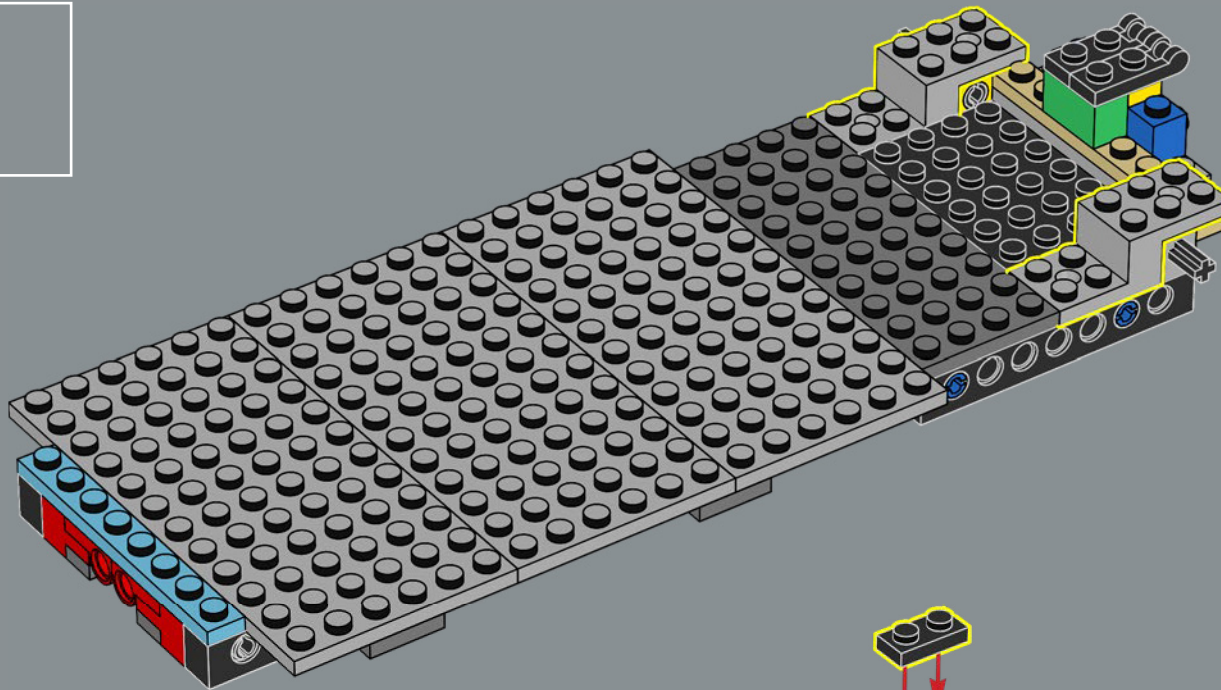

16

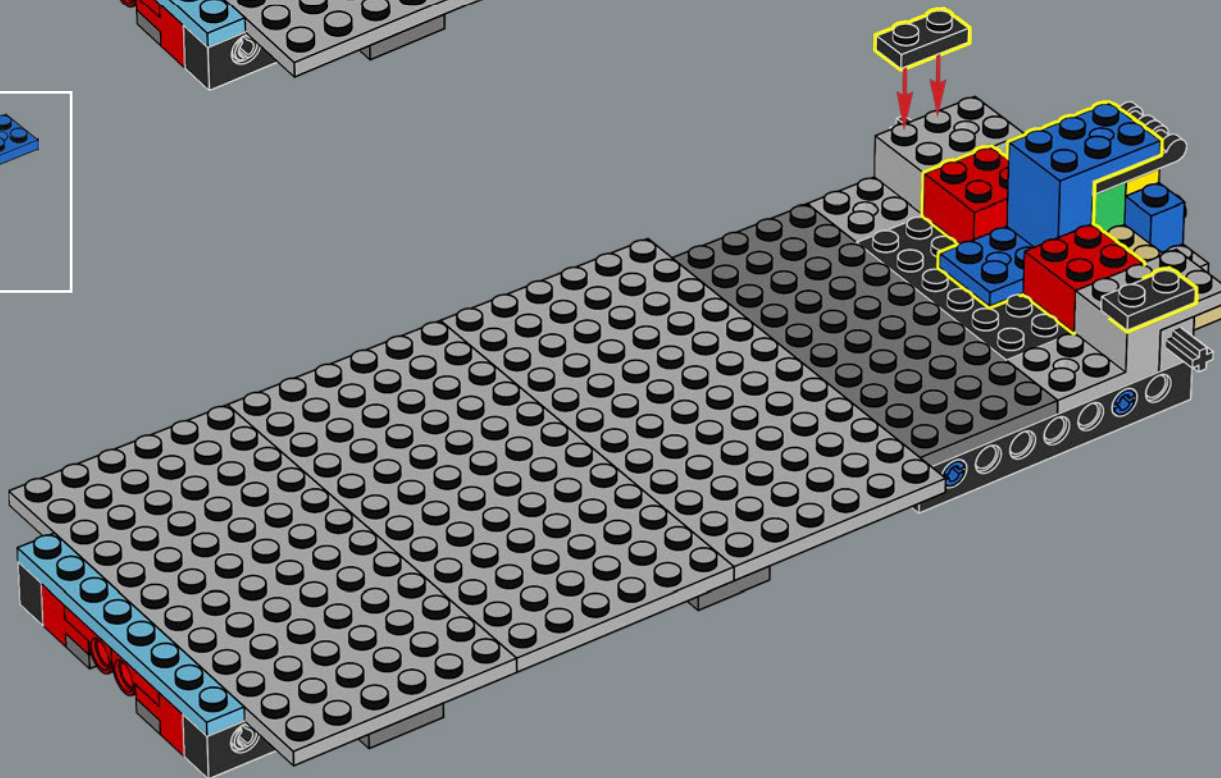

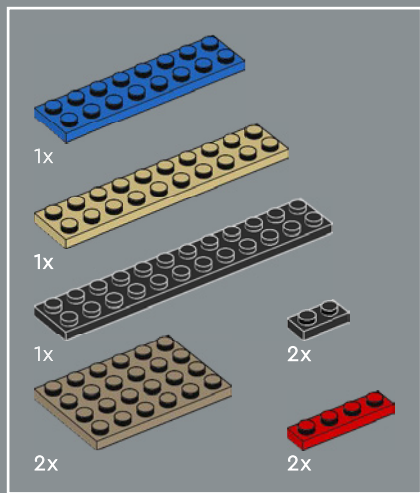

17

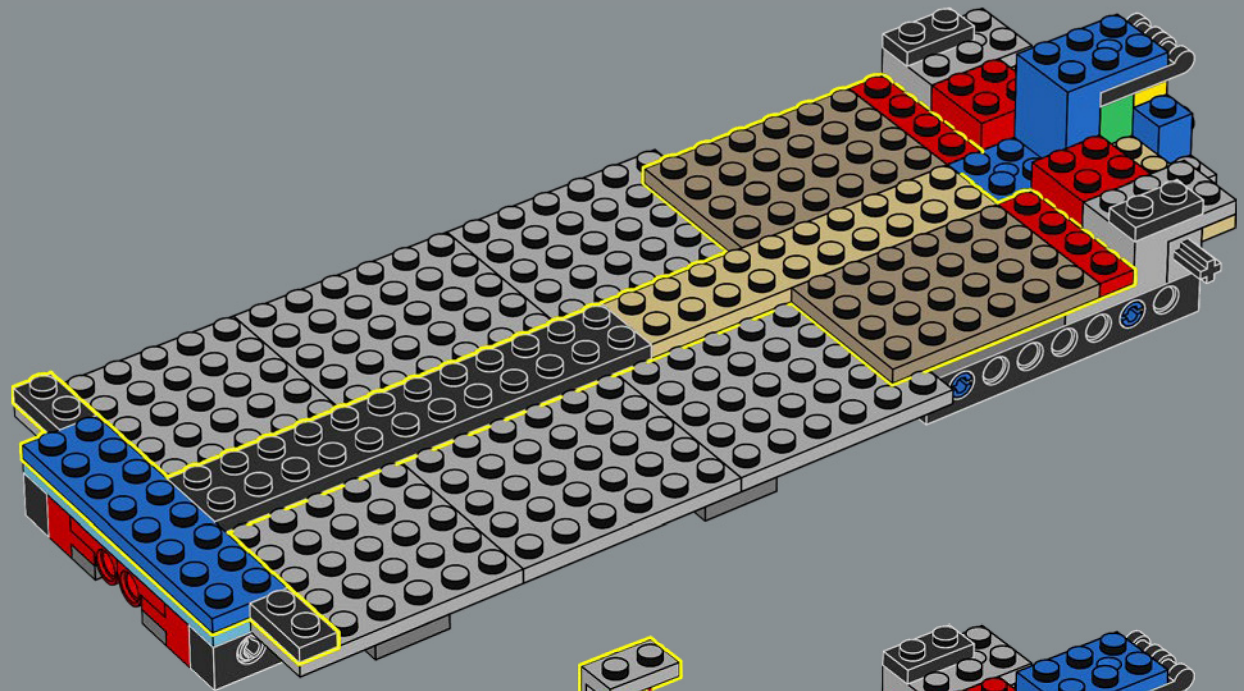

18

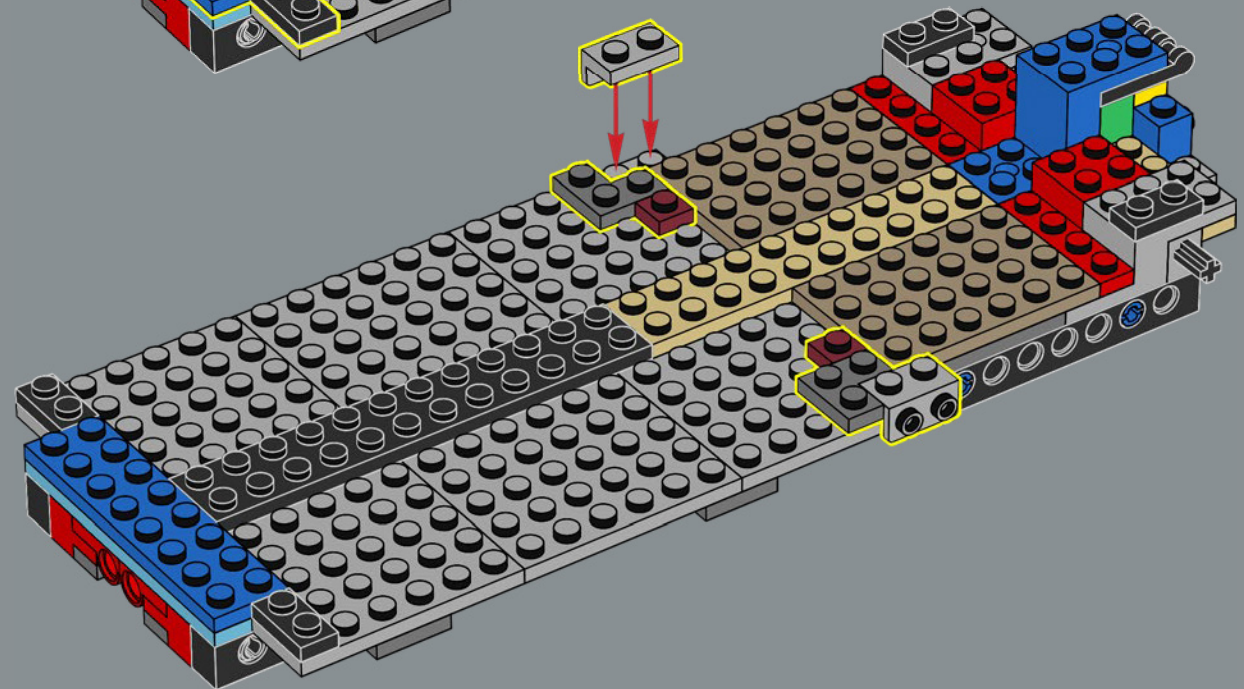

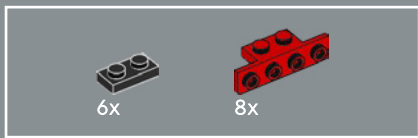

19

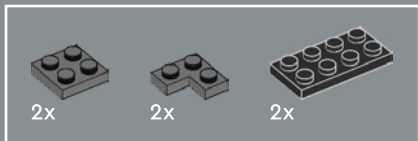
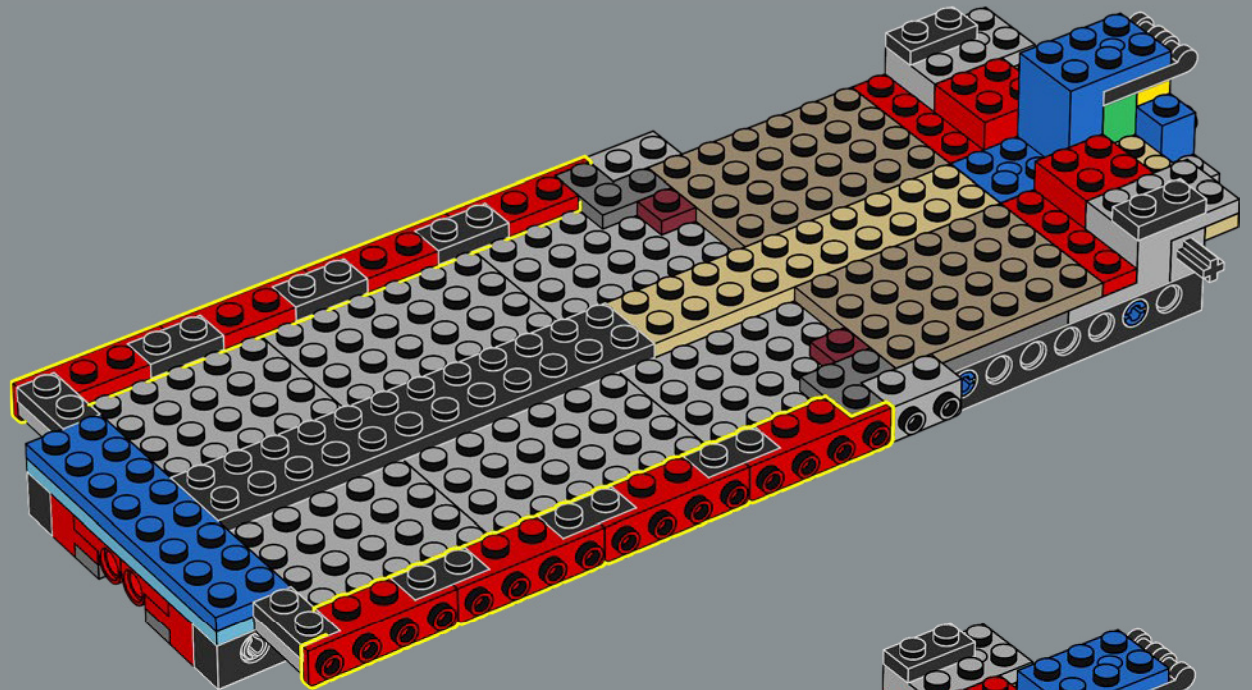

20

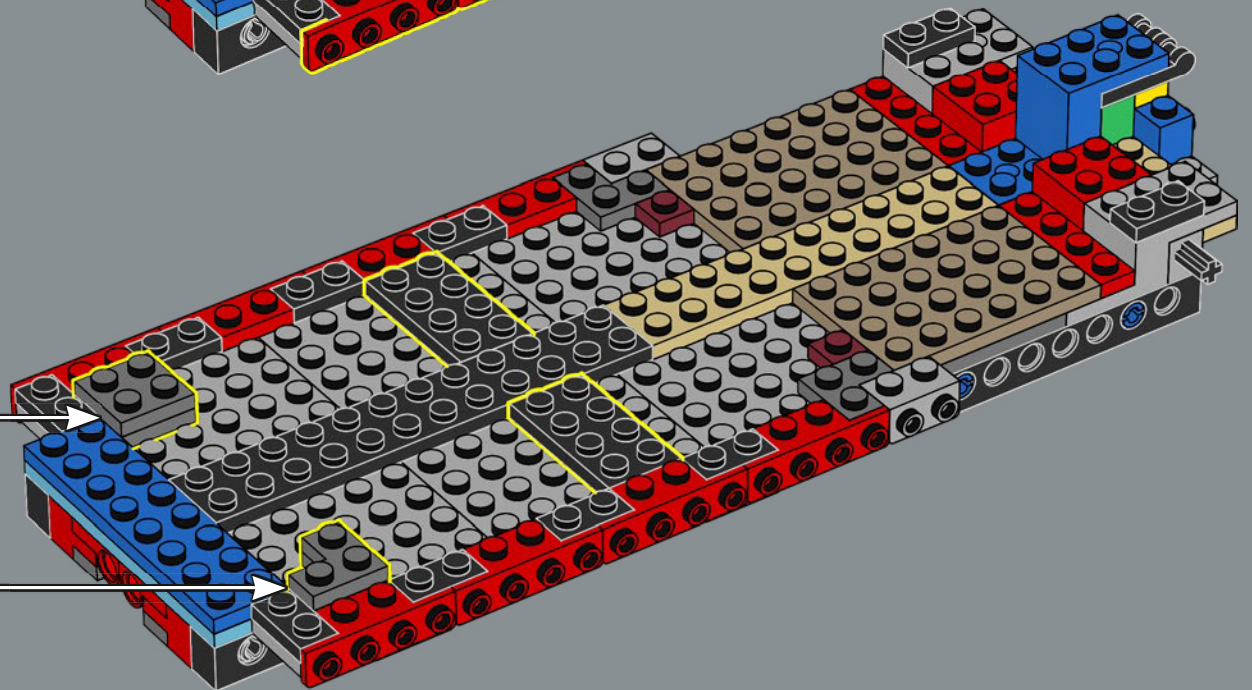
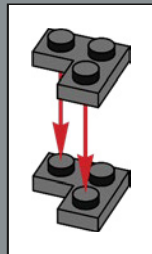
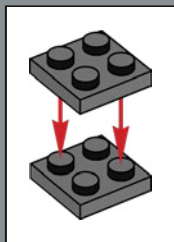

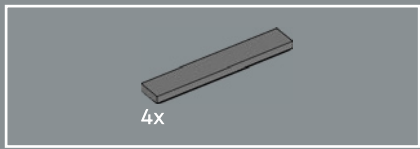

21

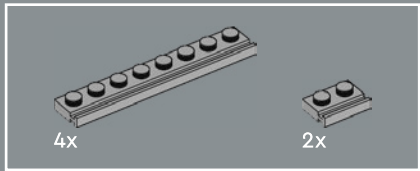
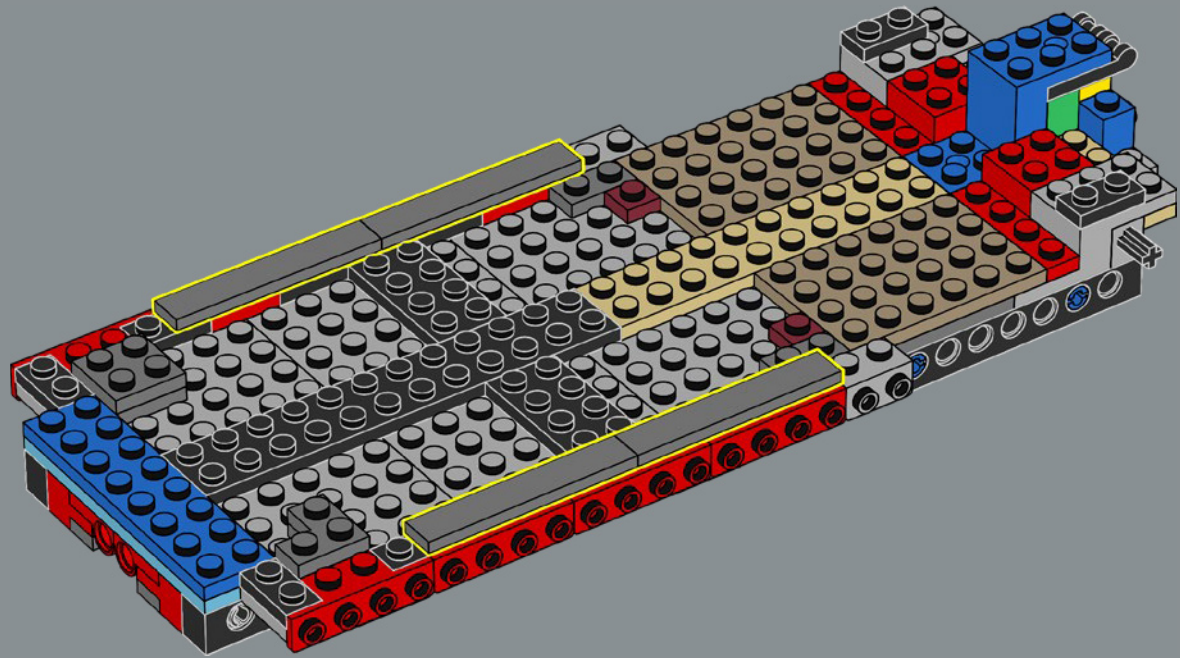

22

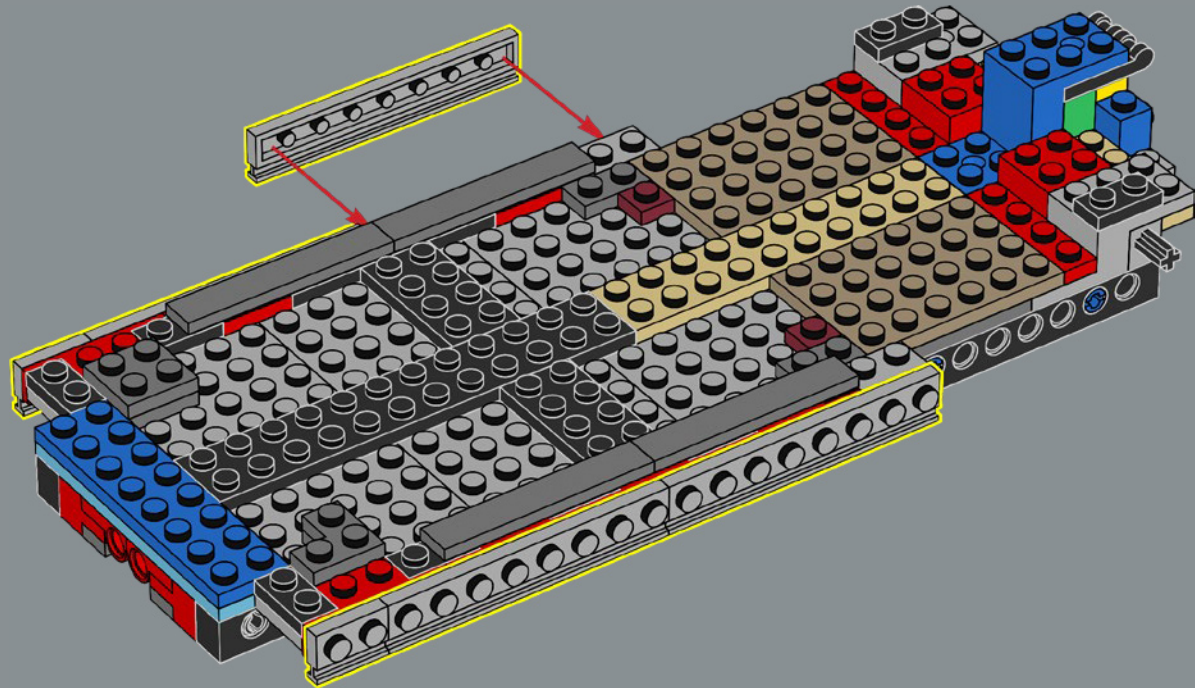



23

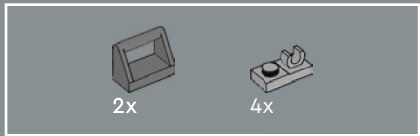
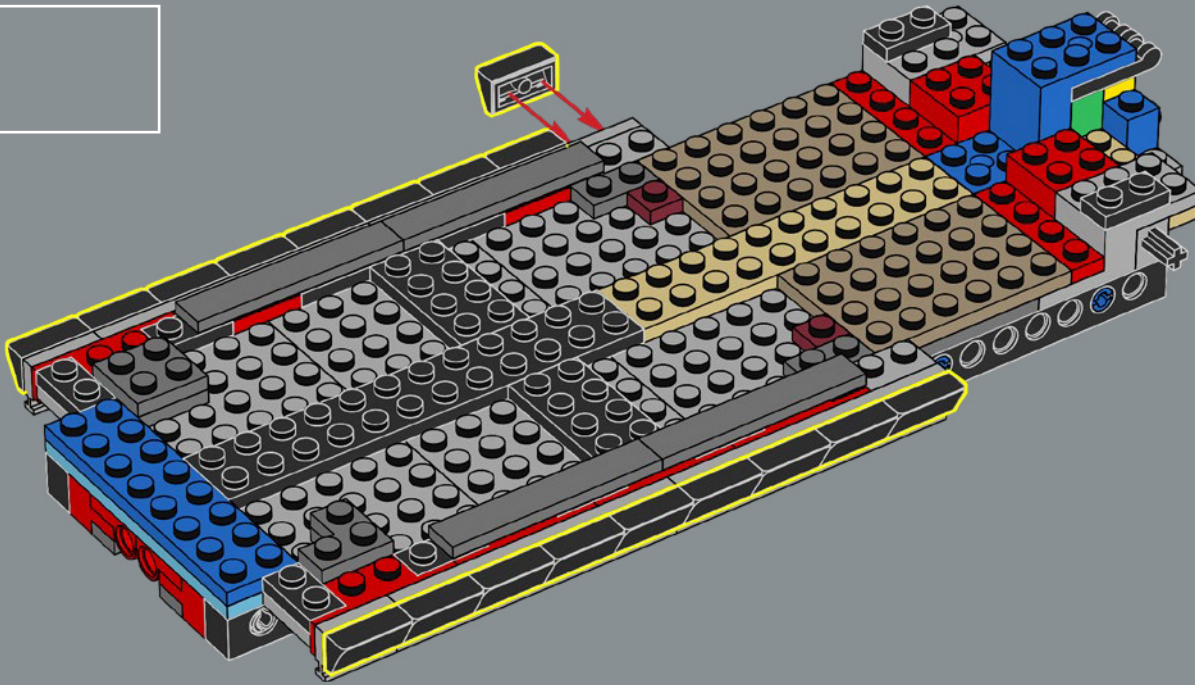

24

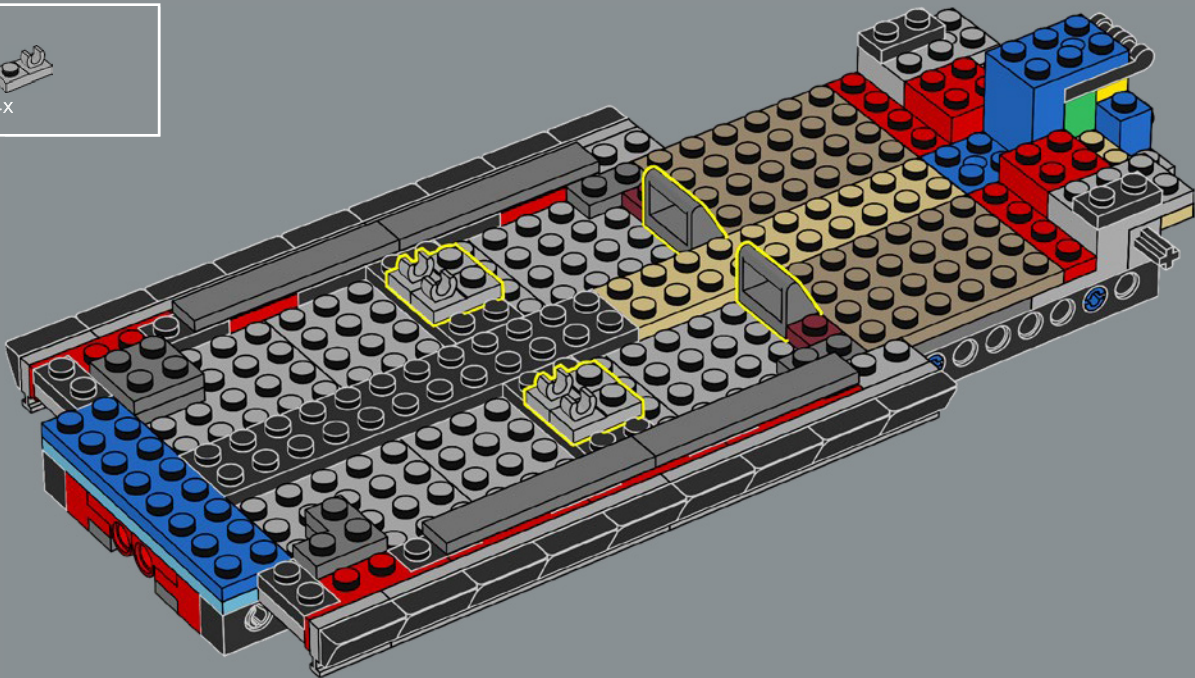



4x

25

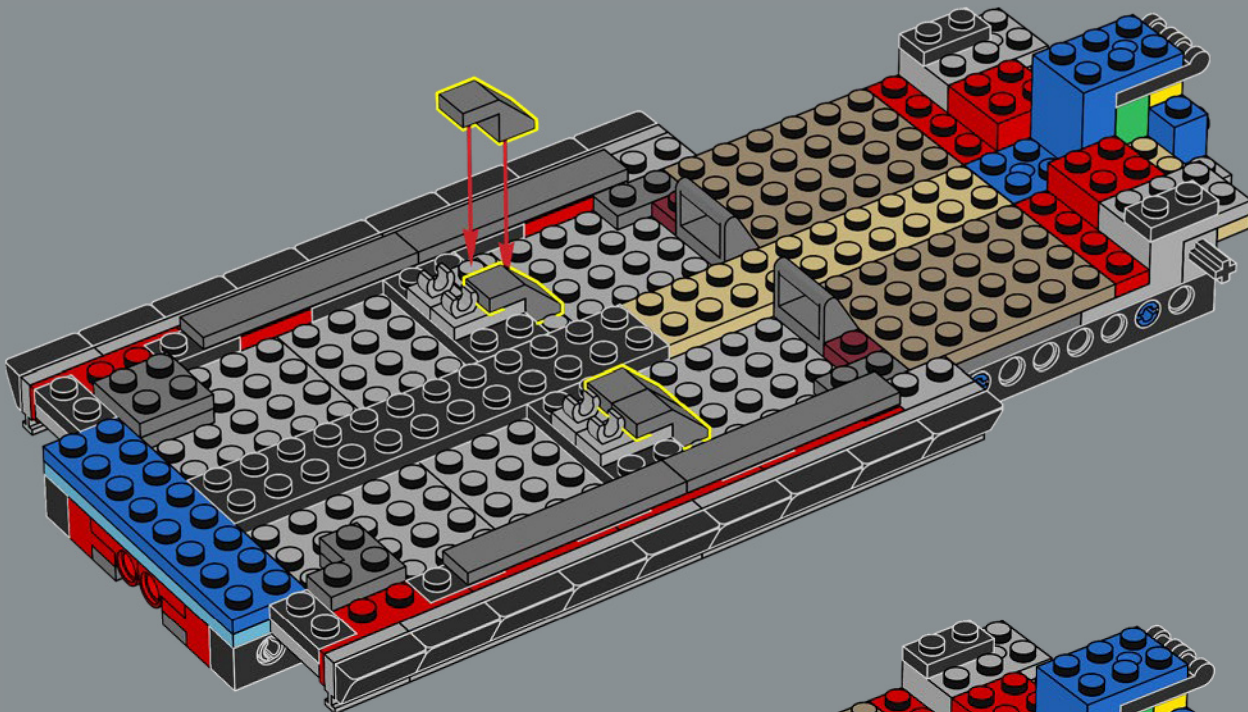

1x



1x



1x

26

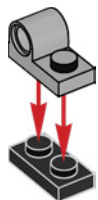
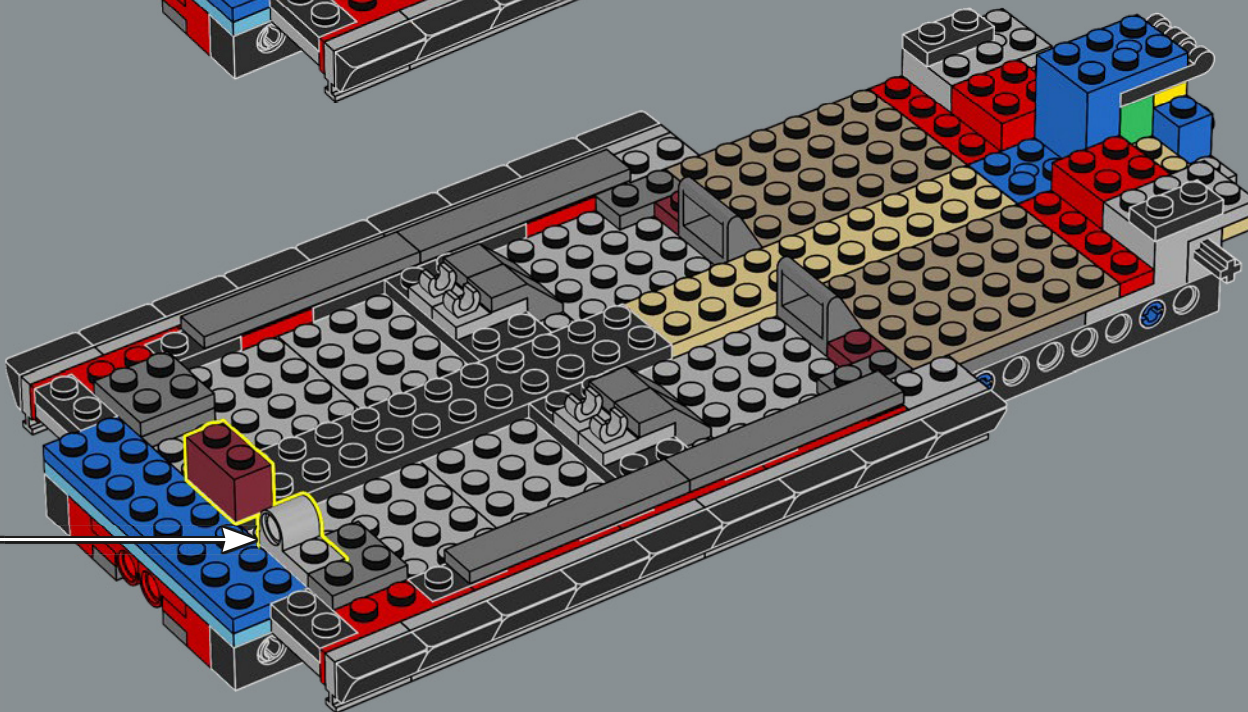

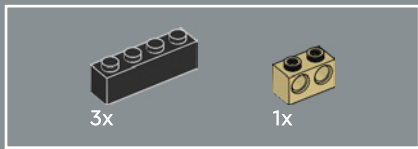

27

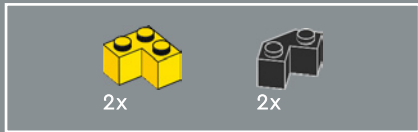
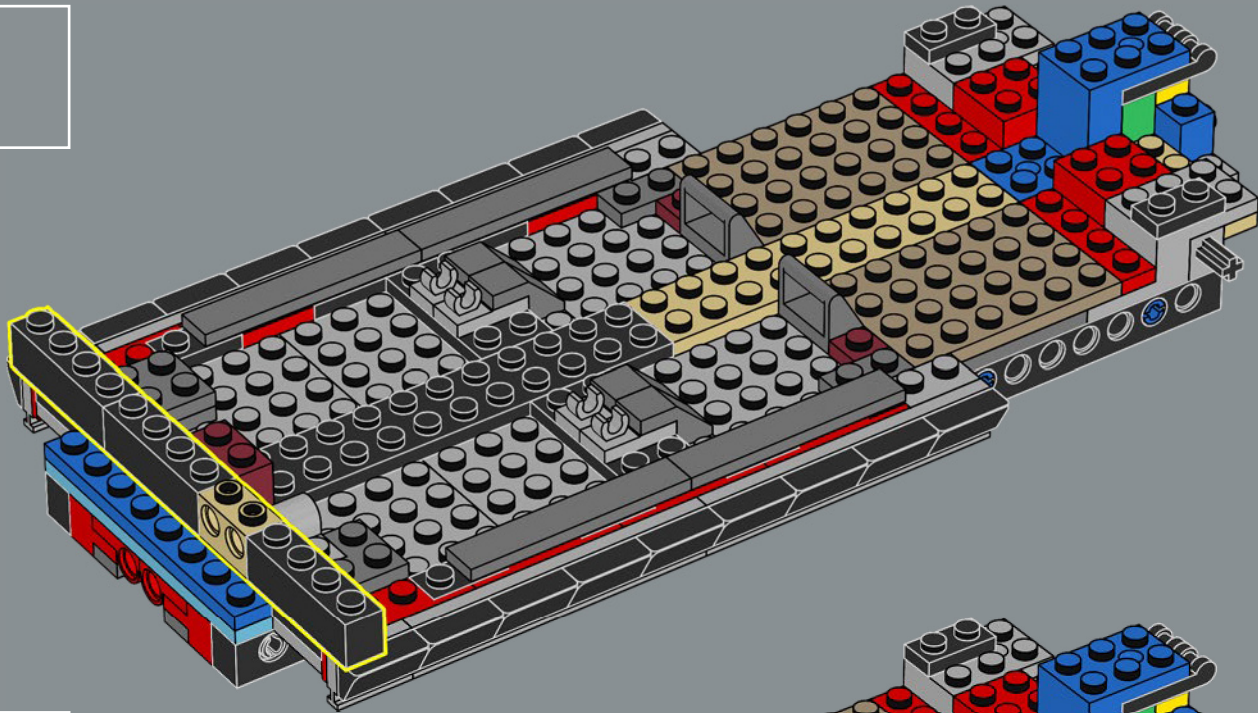

28

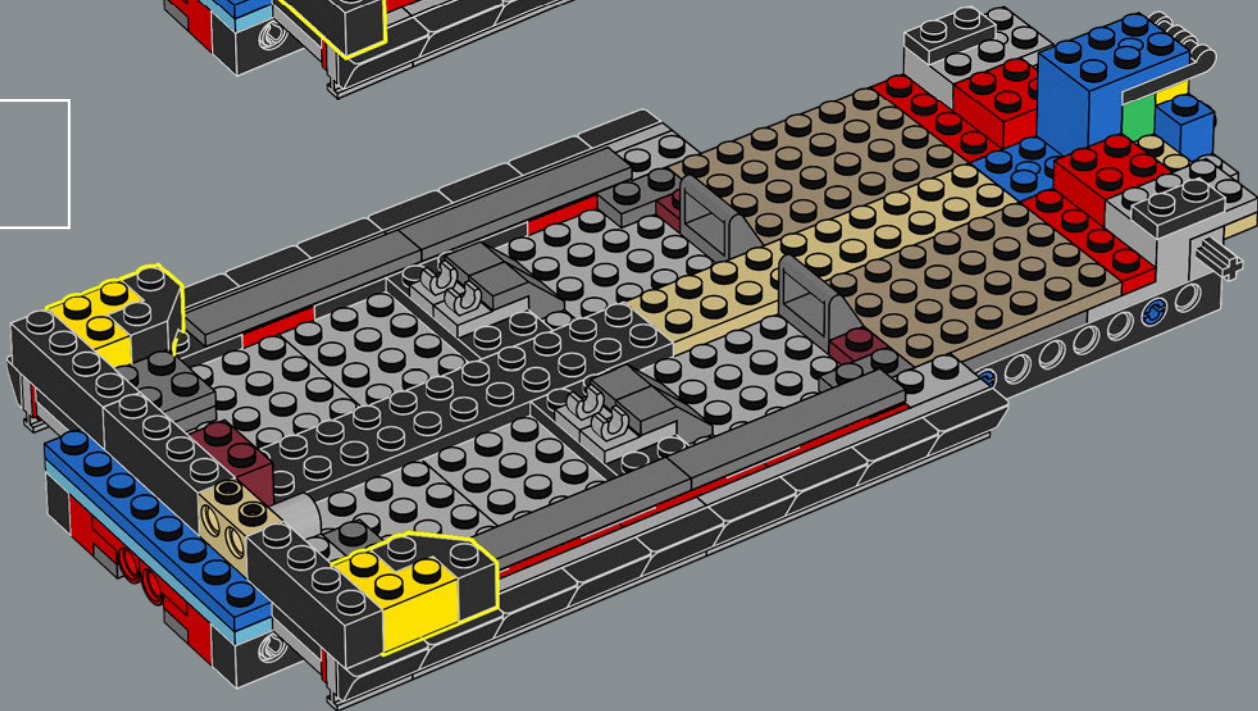



29

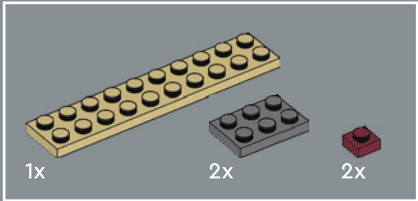
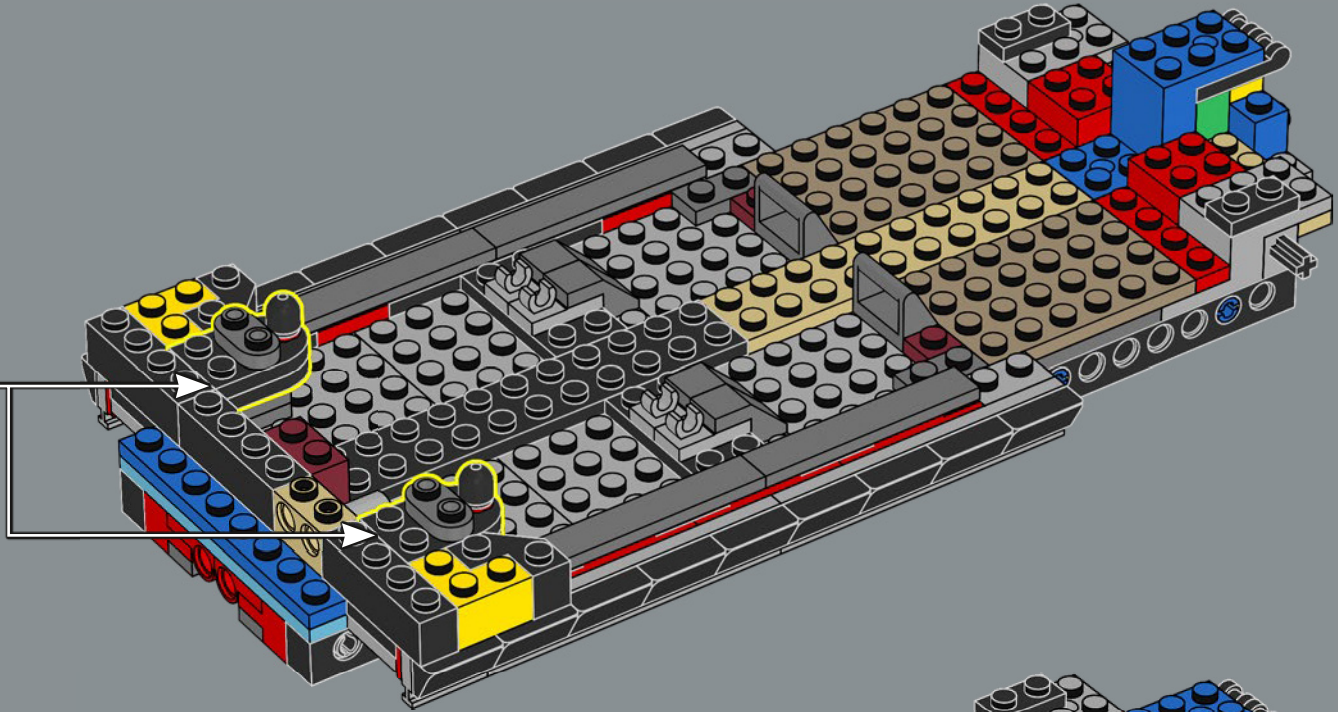
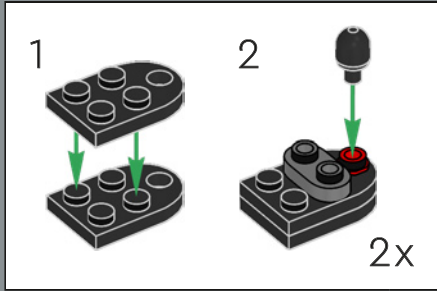

30

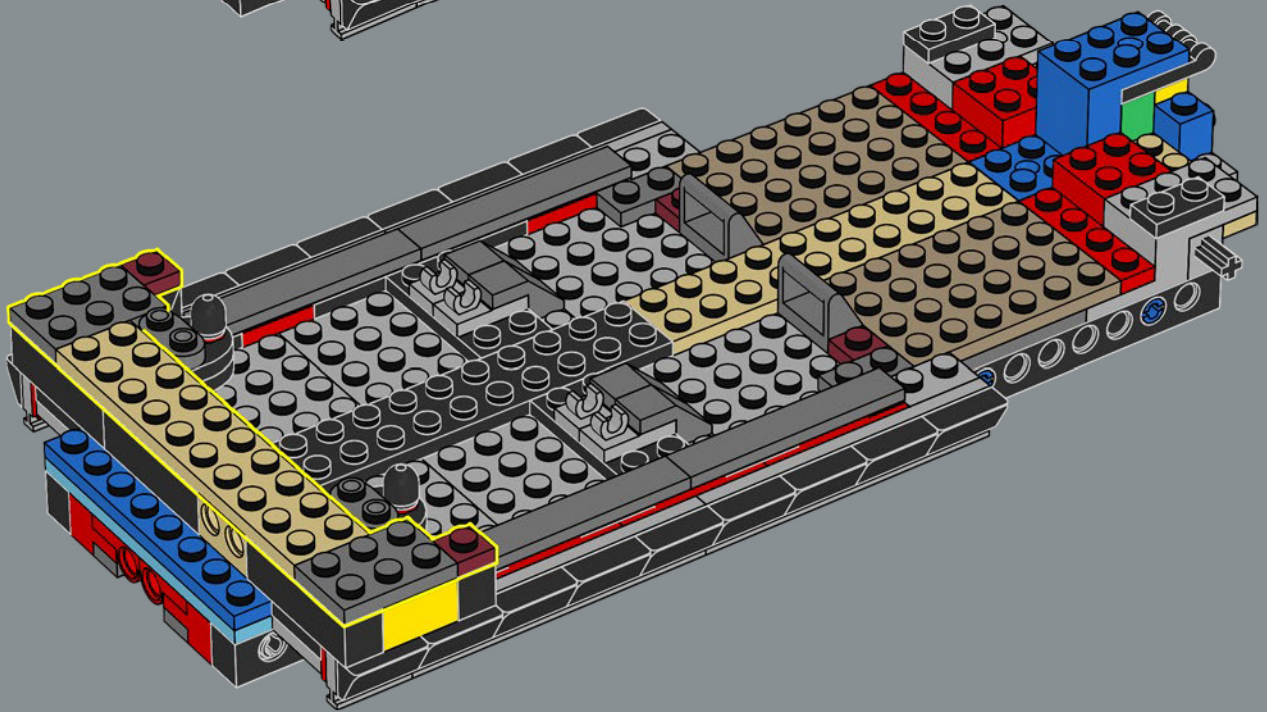

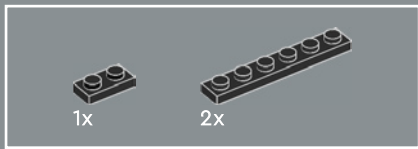

31

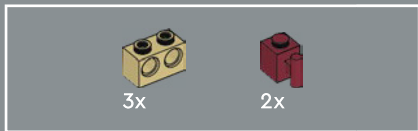
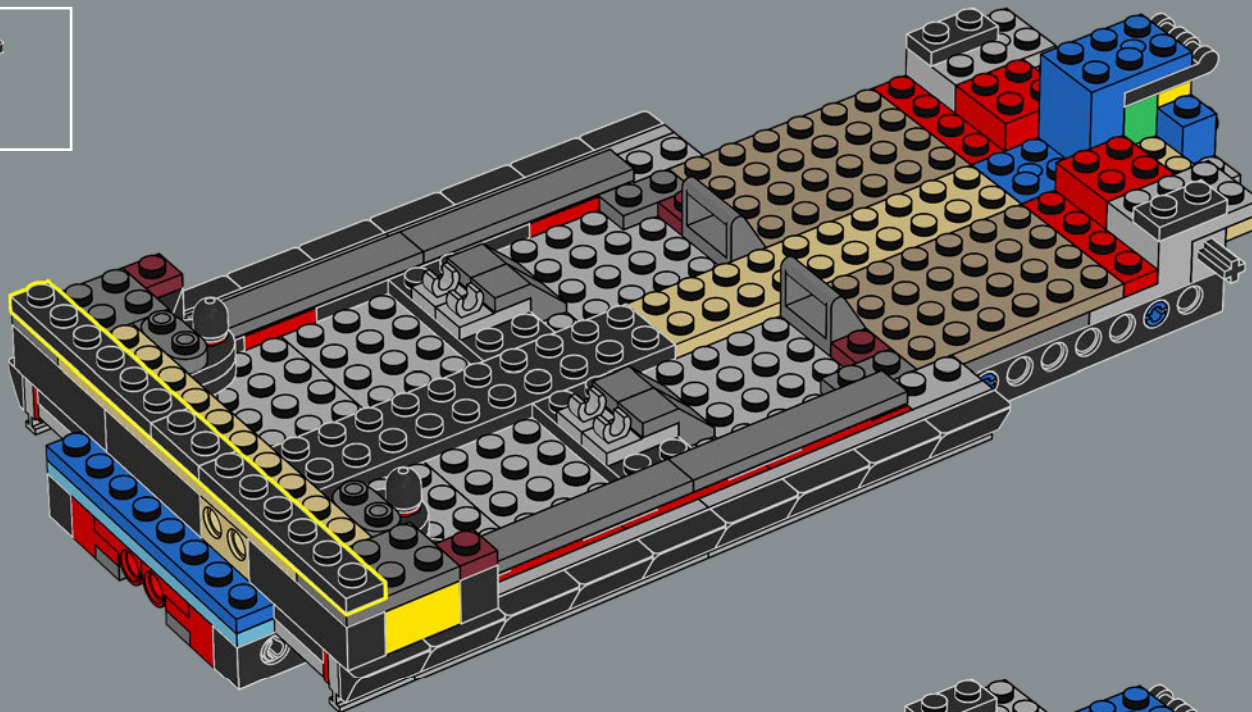

32

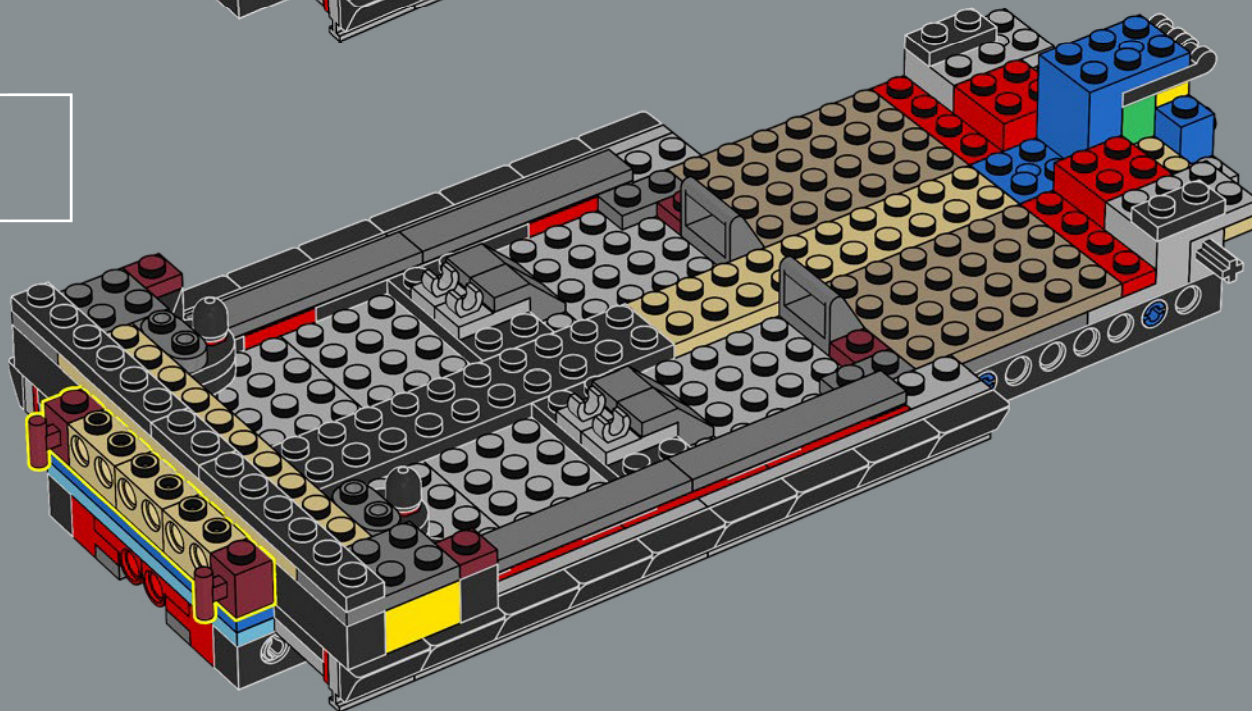

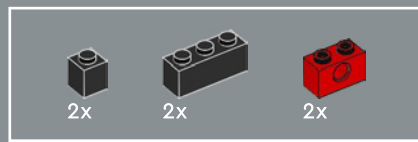

33

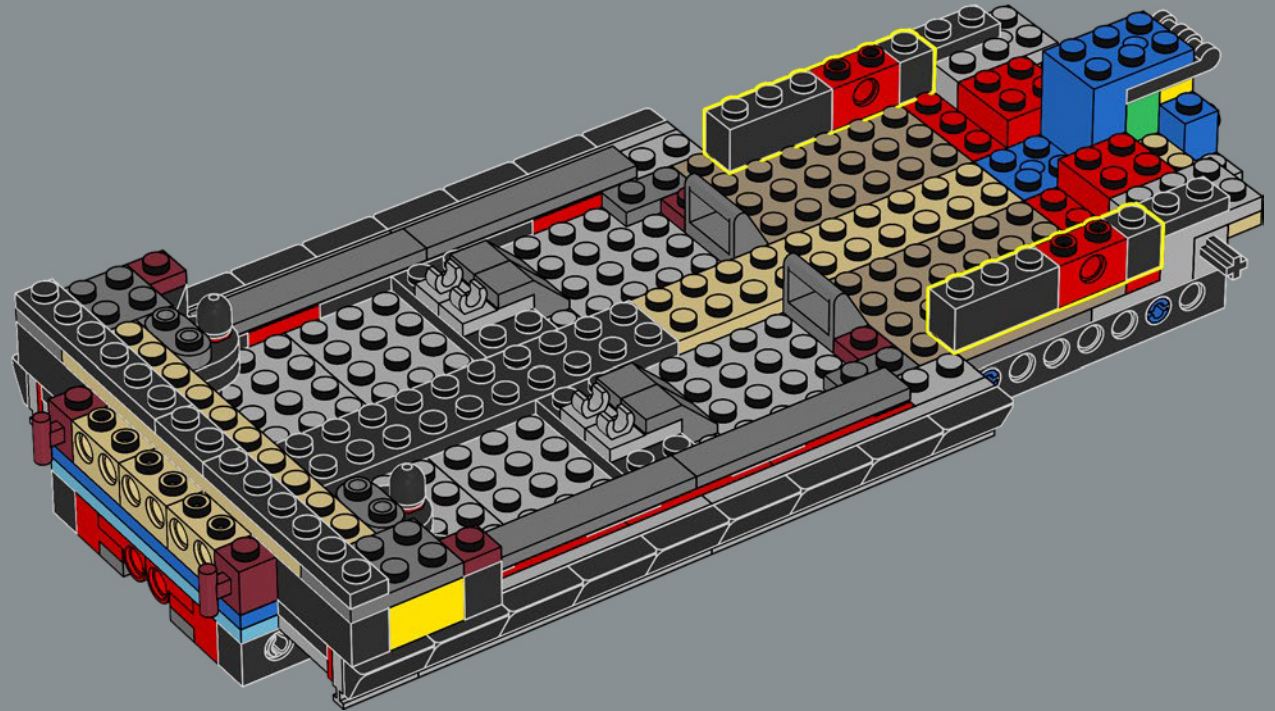

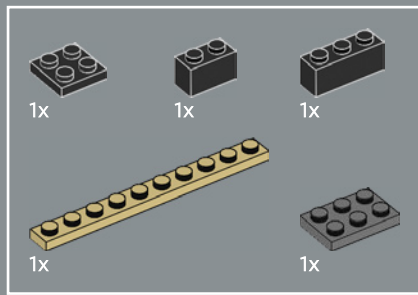

34

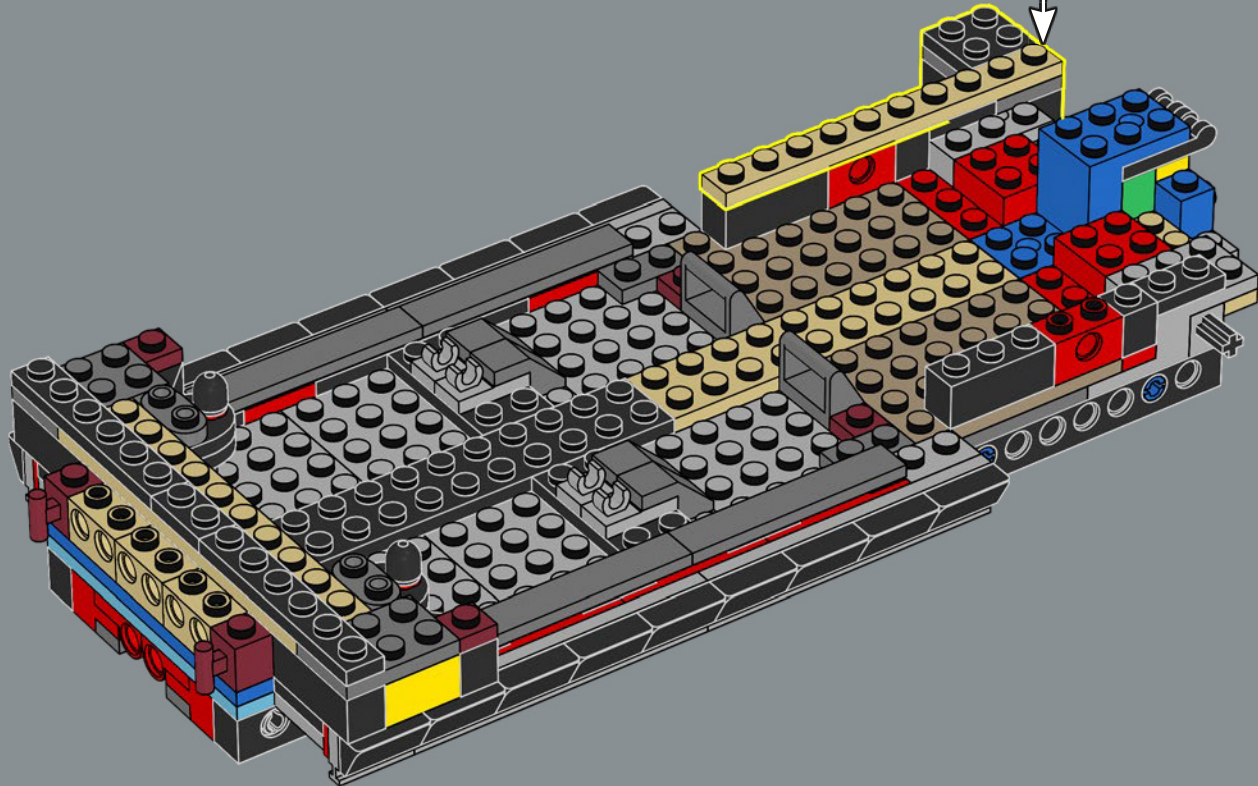
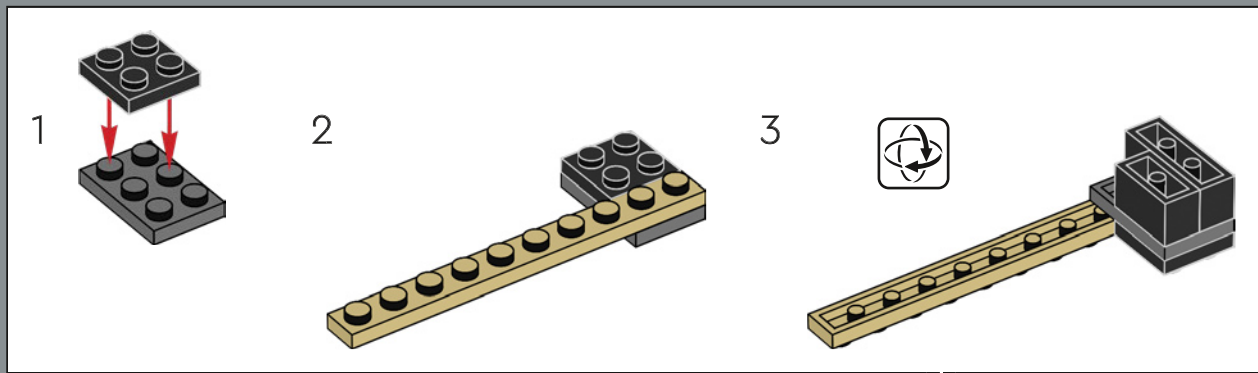

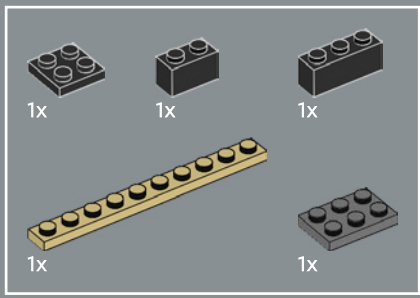

35

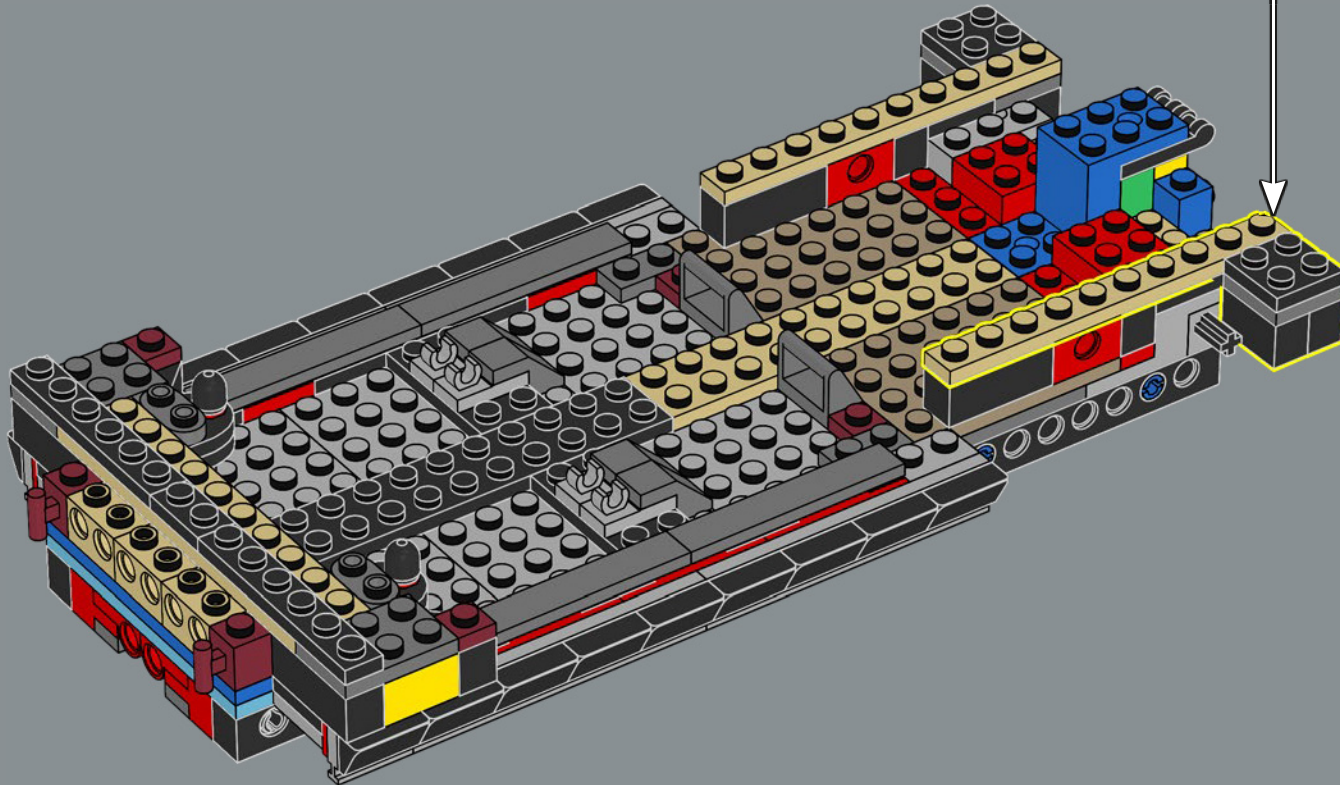
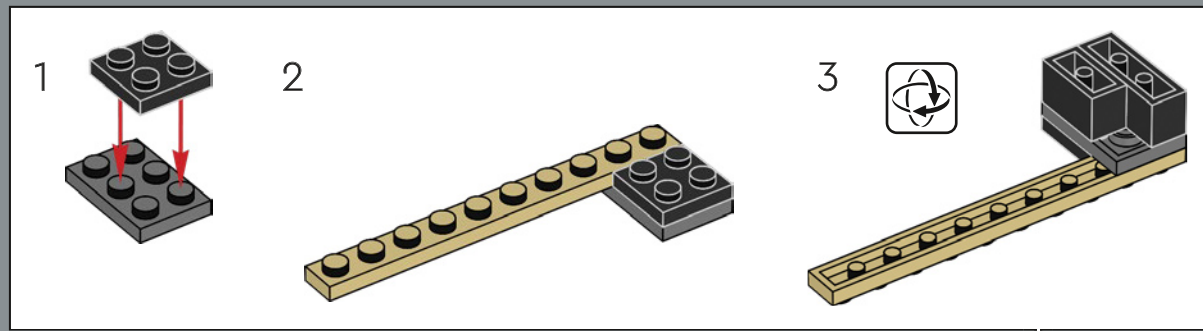

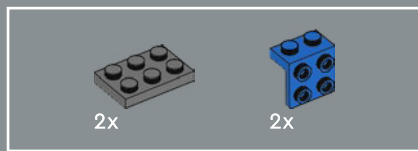

36

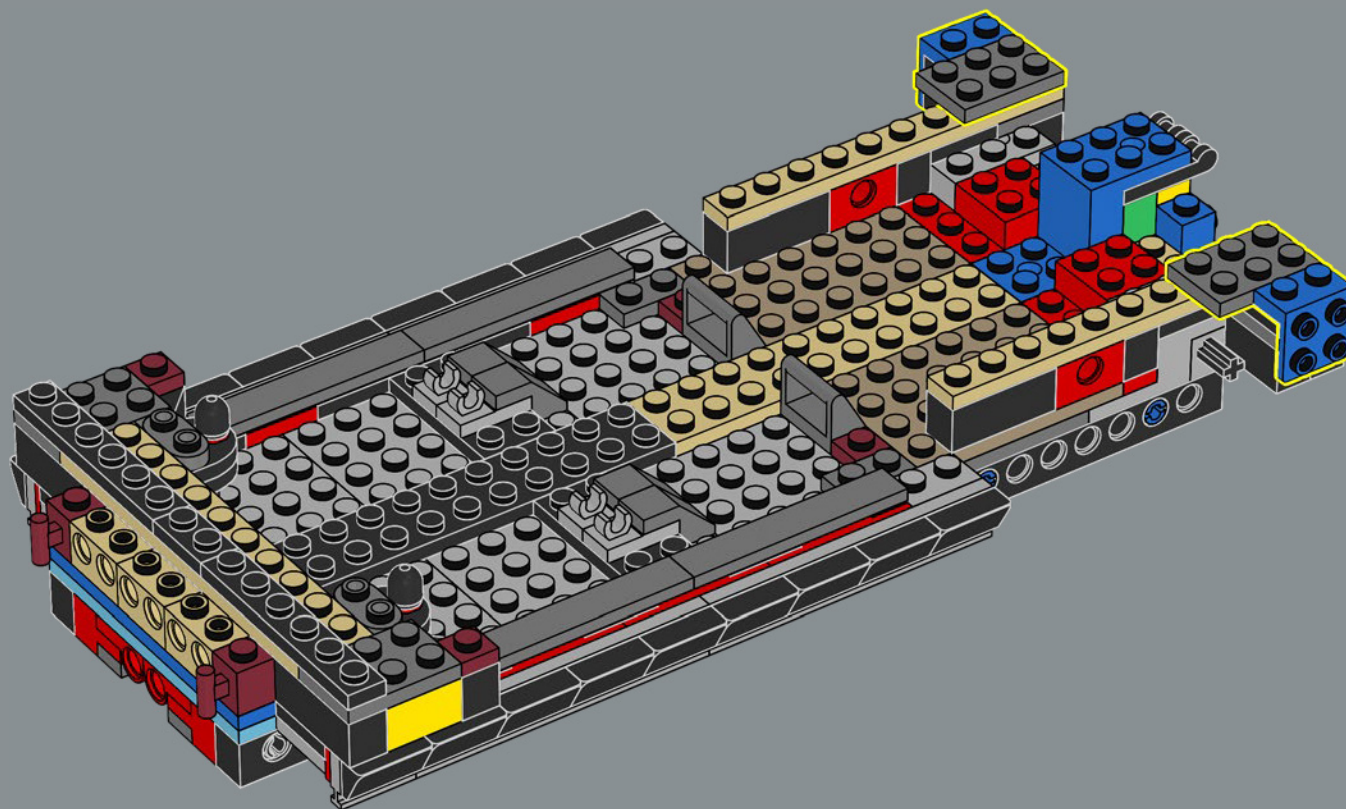

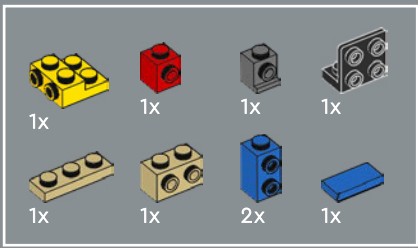

37

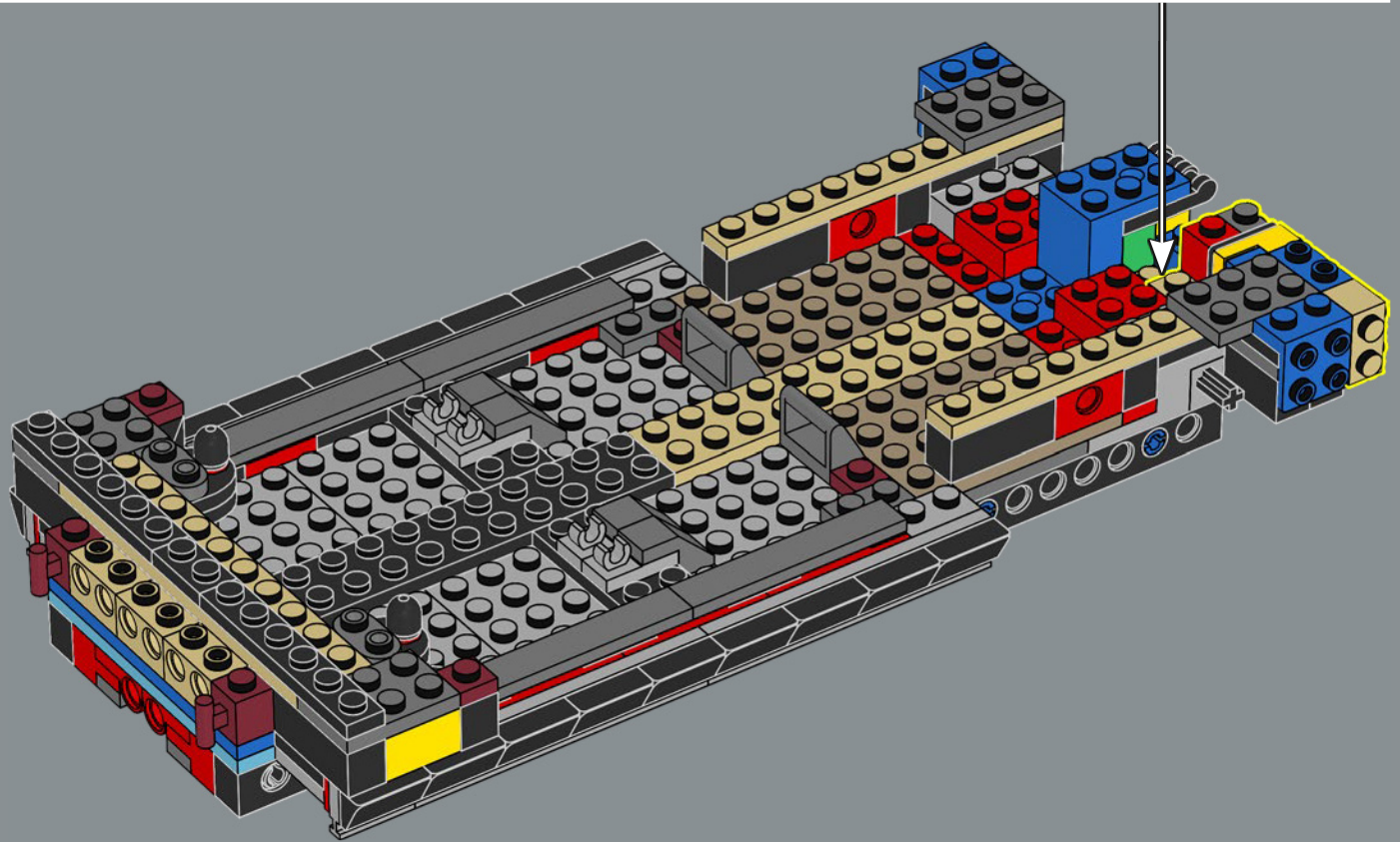
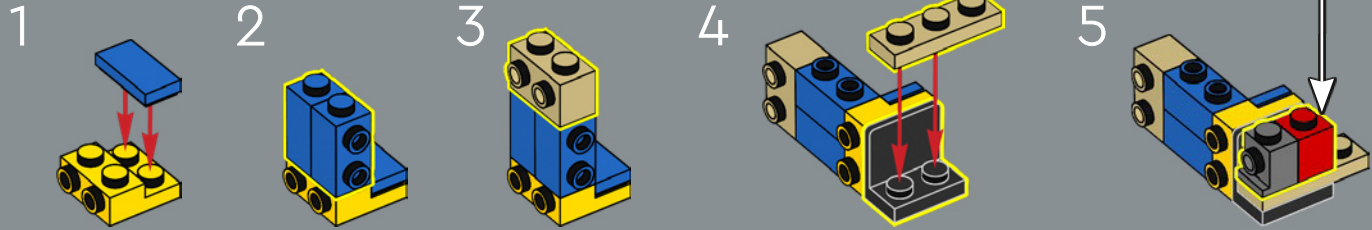

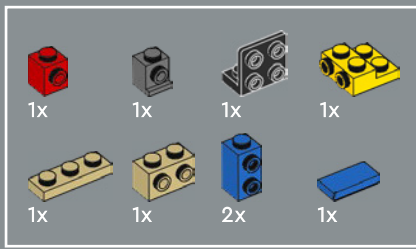

38

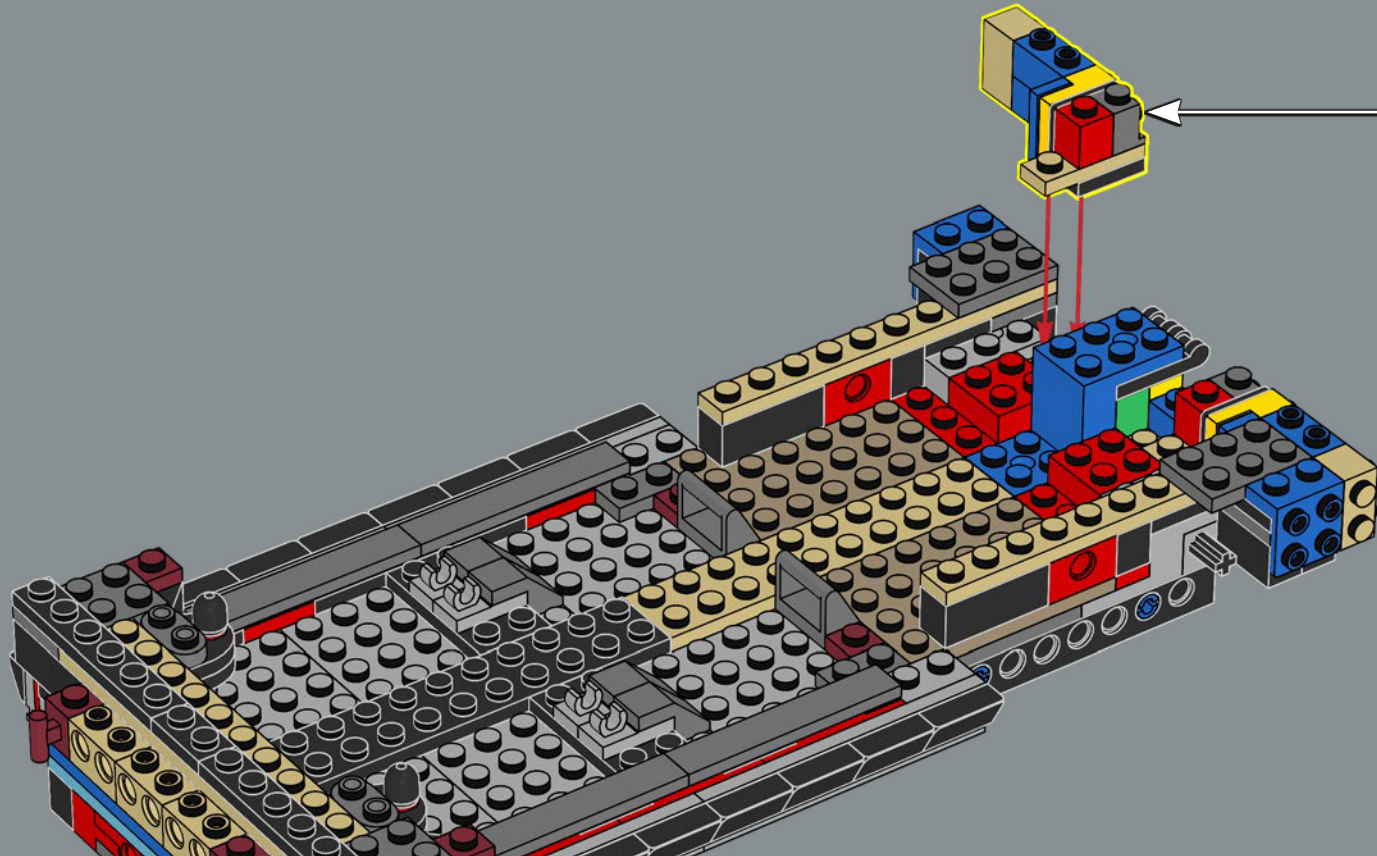
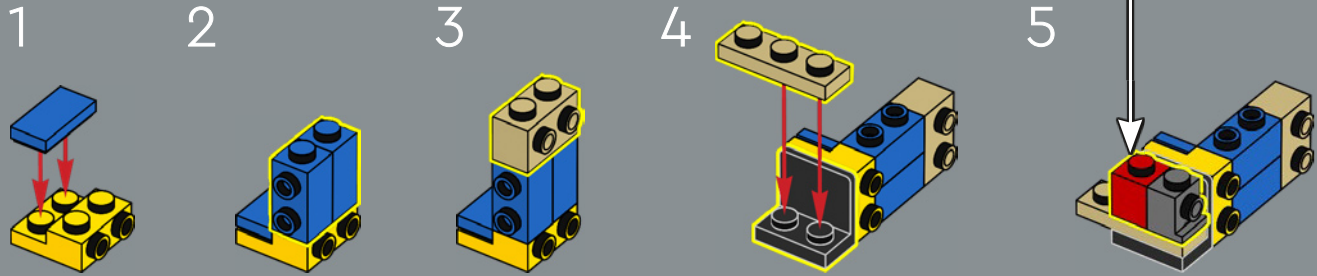

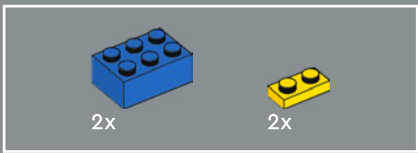

39

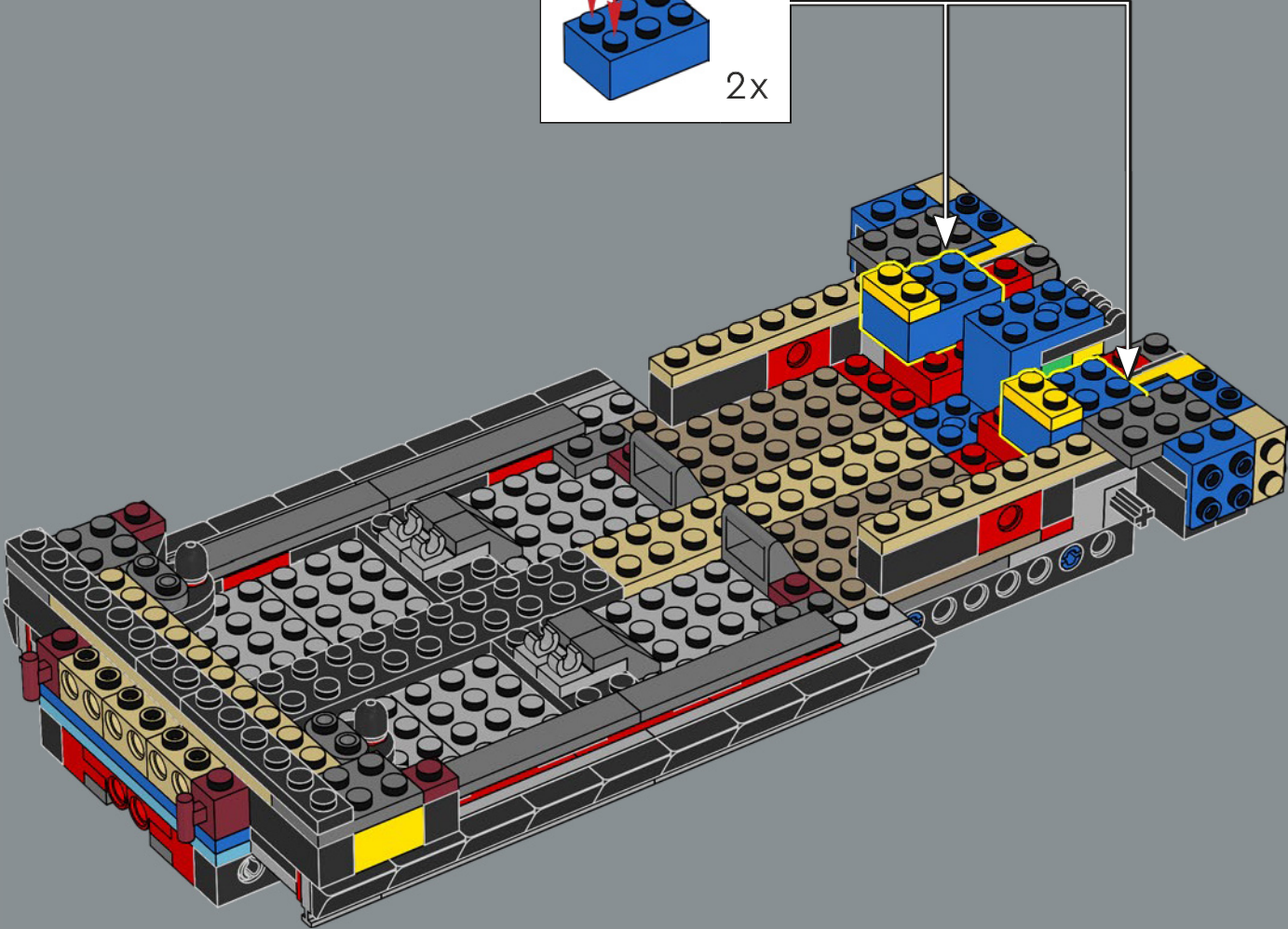
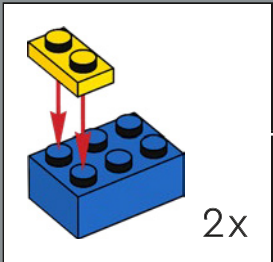

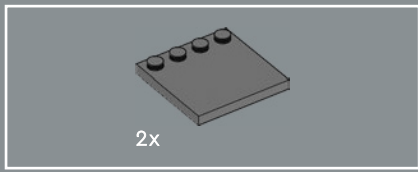

40

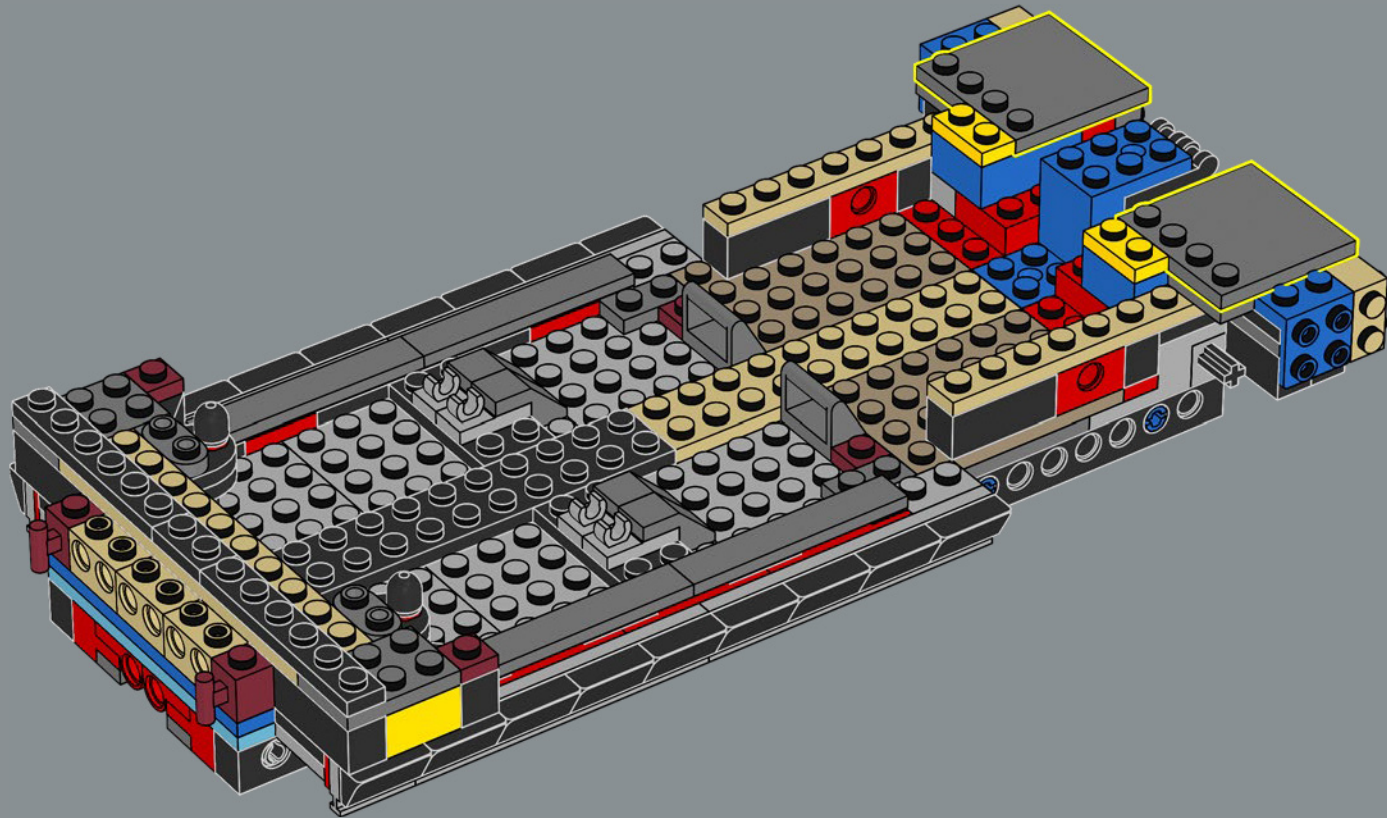



41

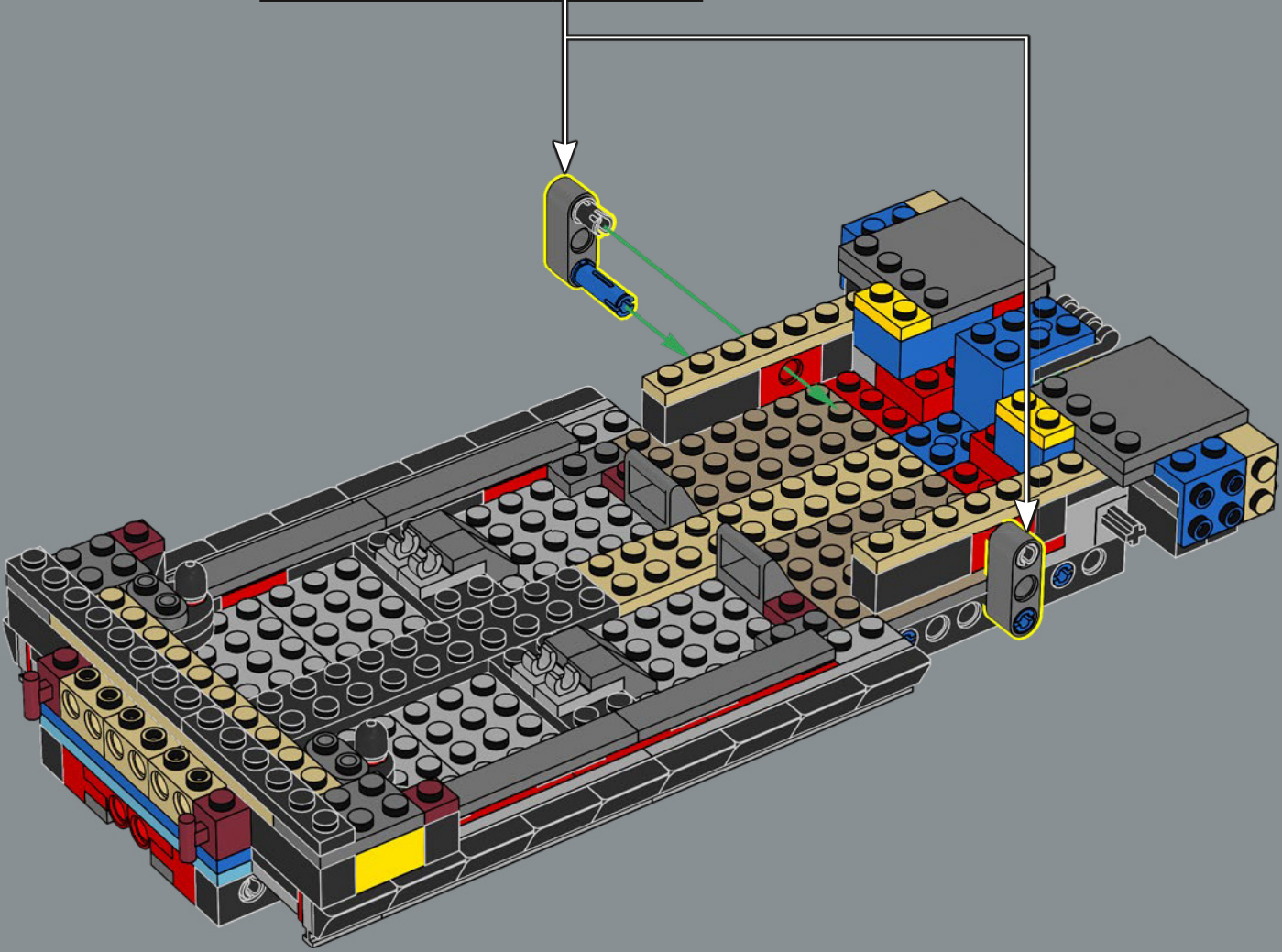
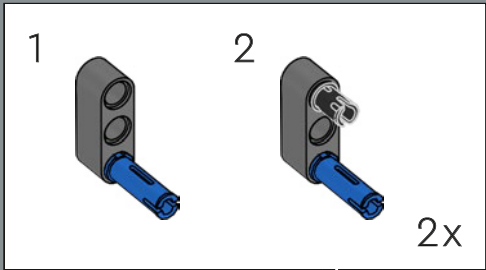

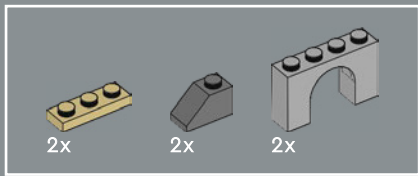

42

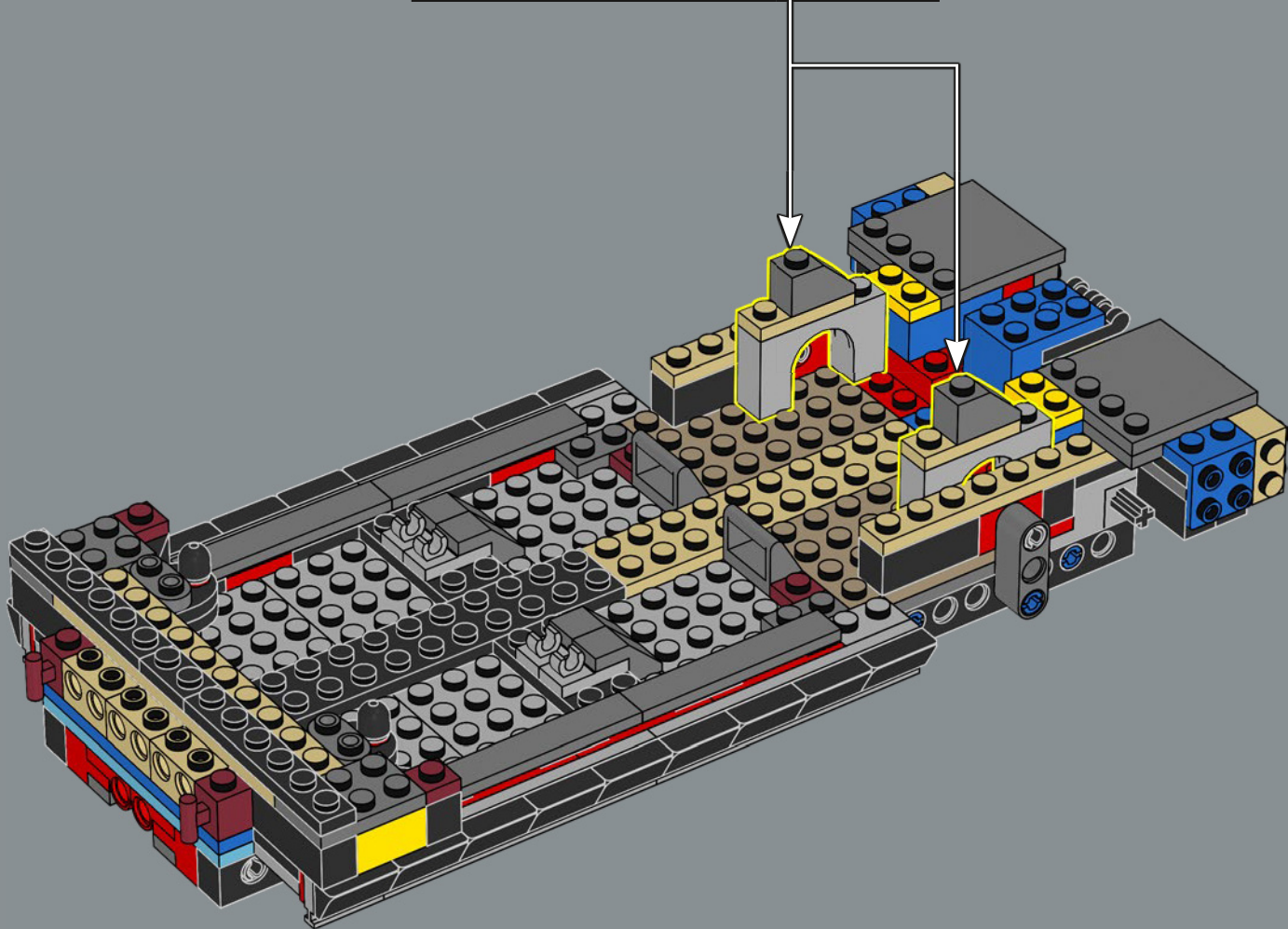
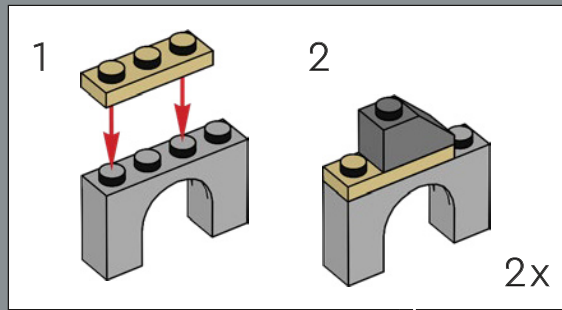

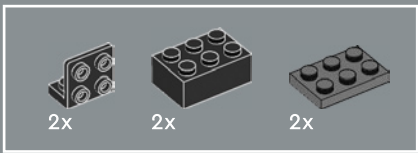

43

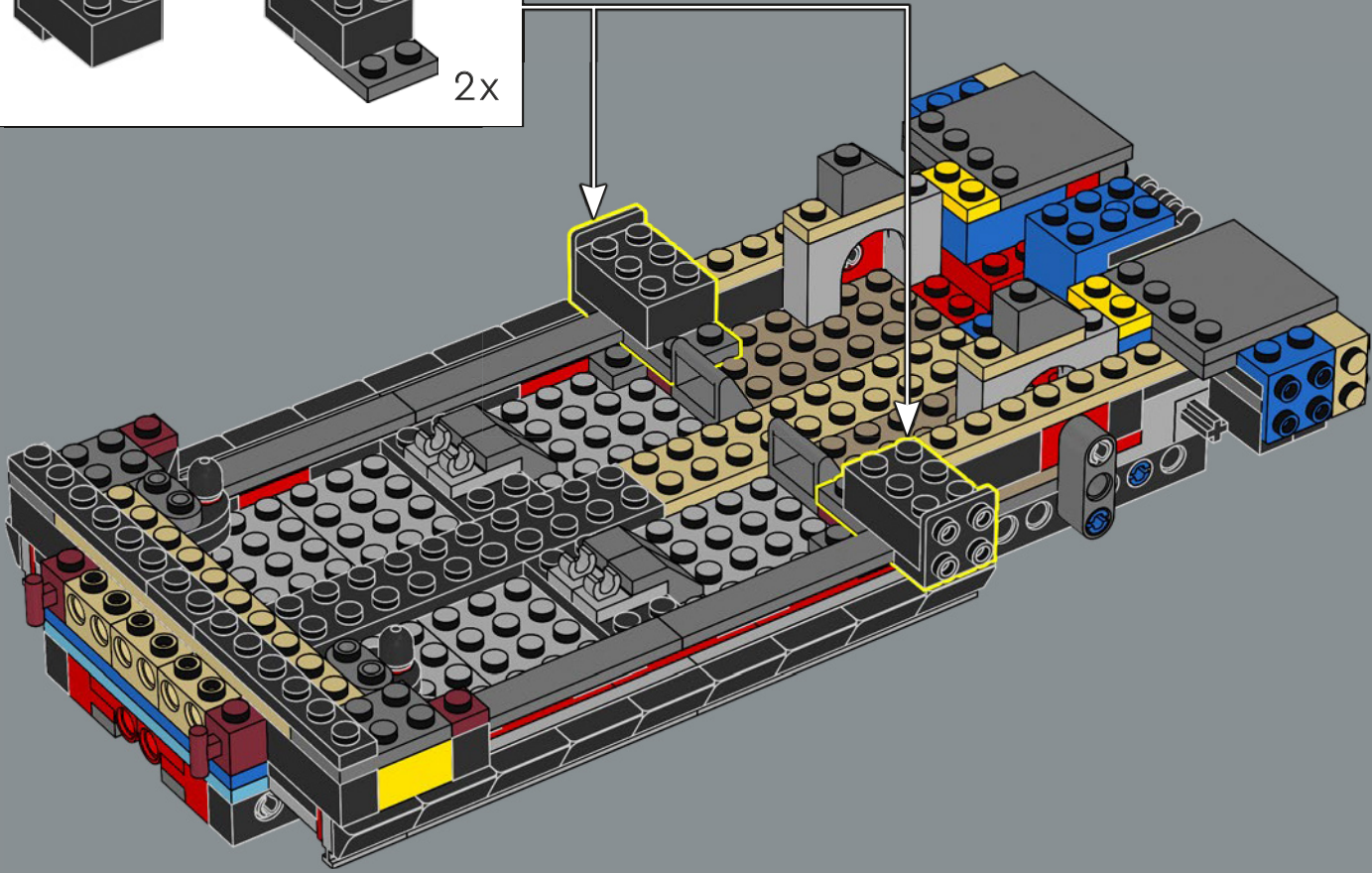
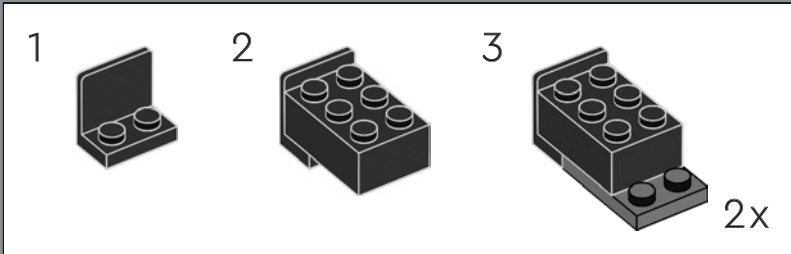

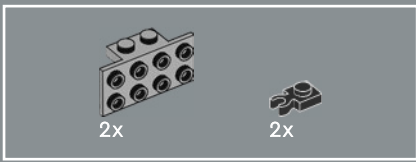

44

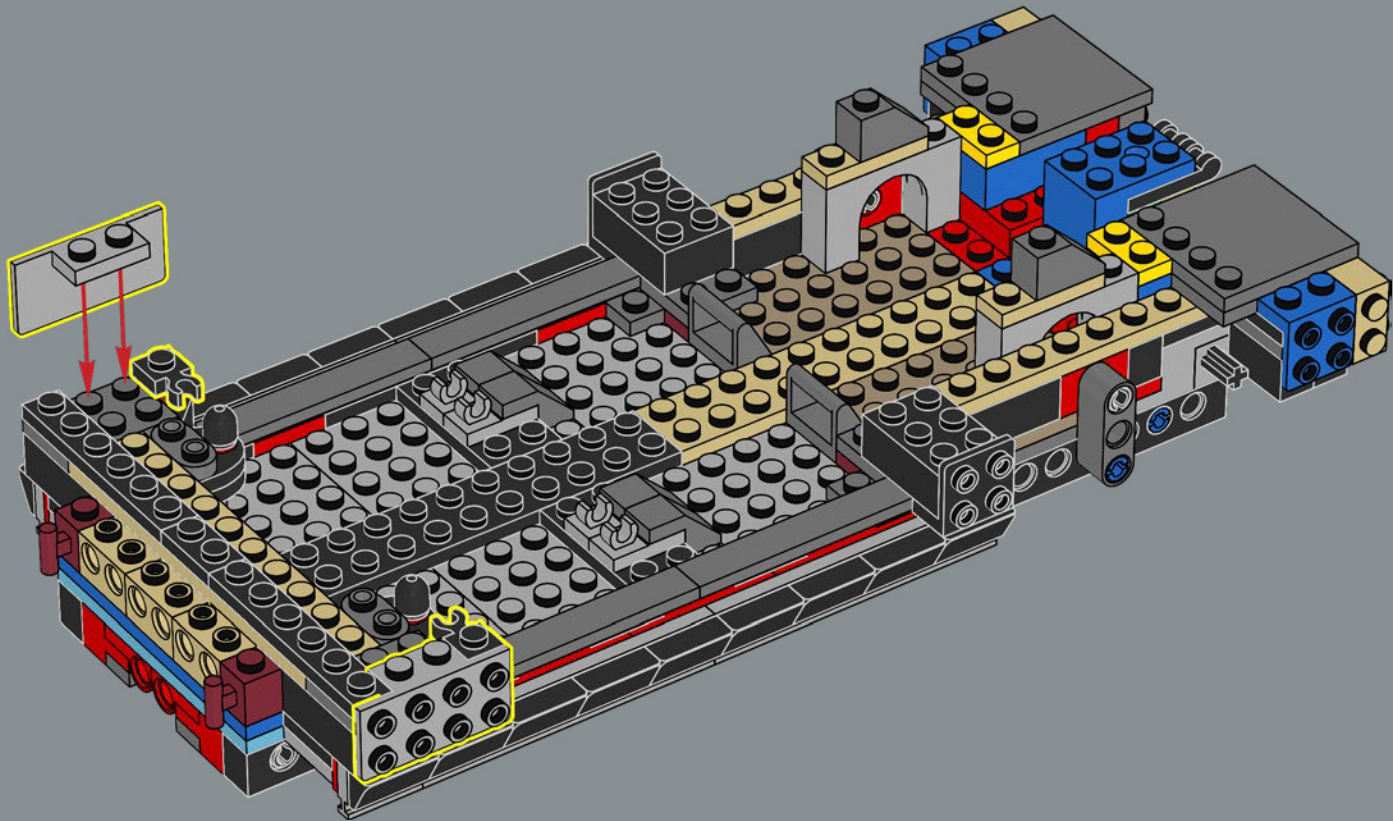

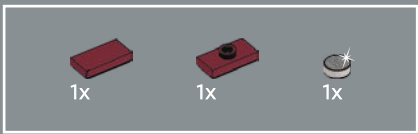

45

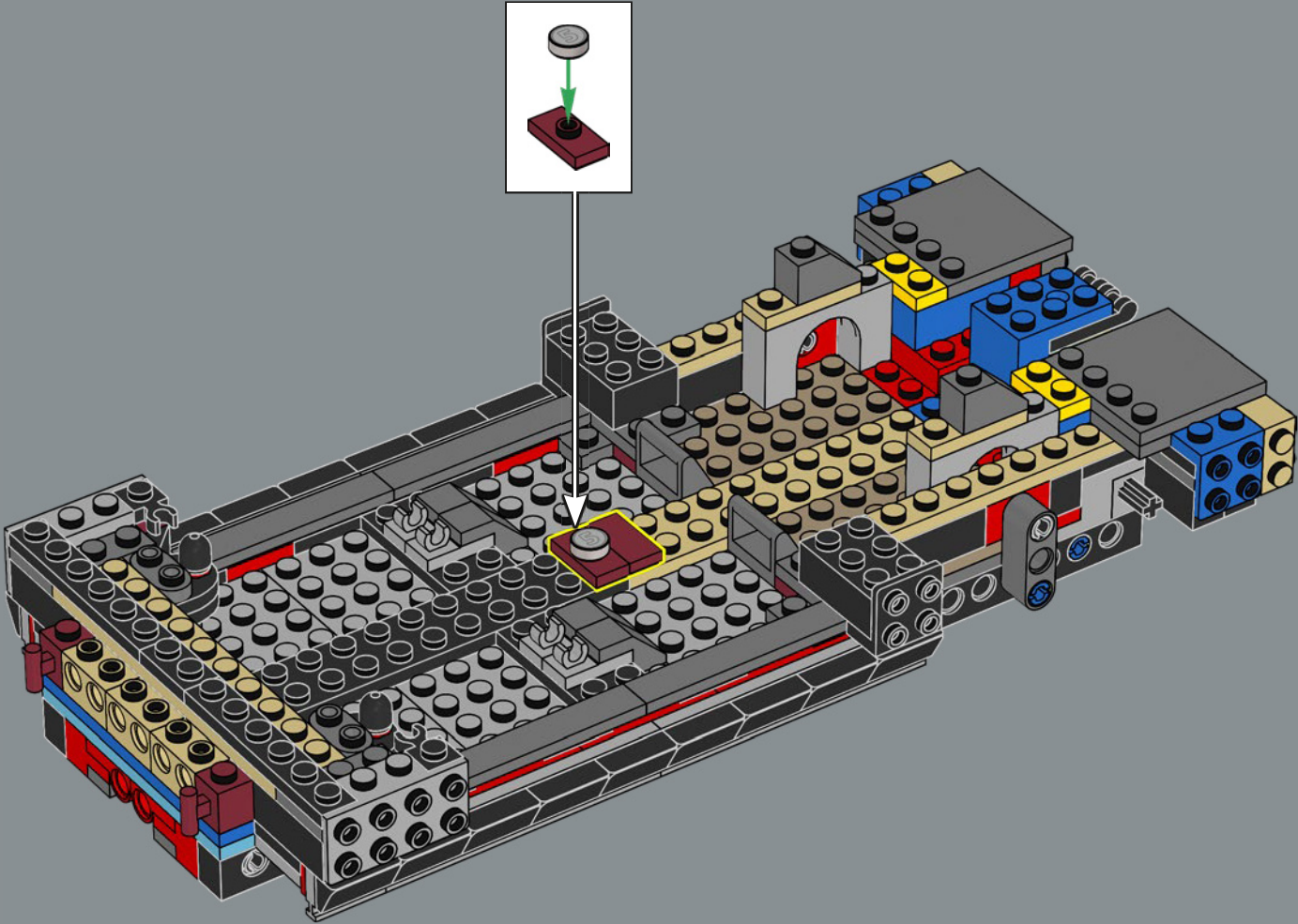

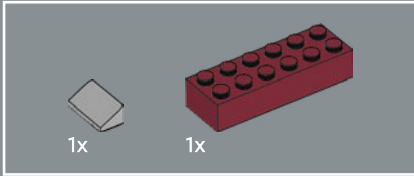
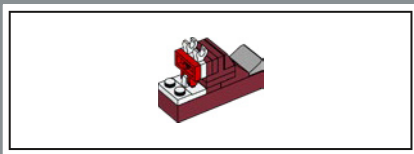

46

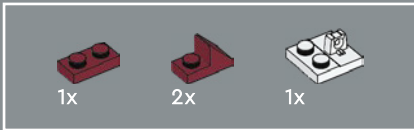
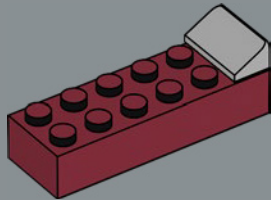

47

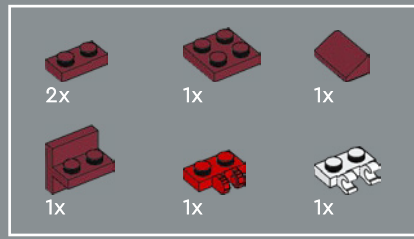
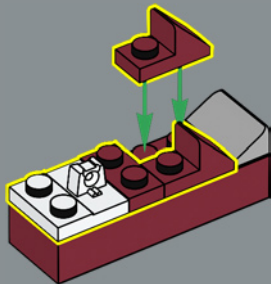

48

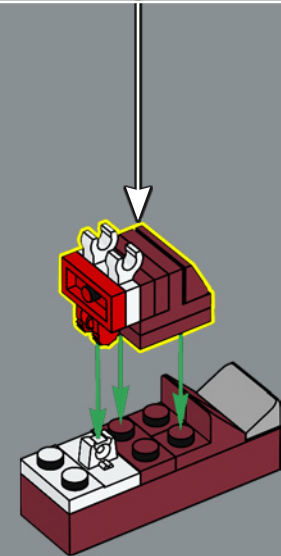
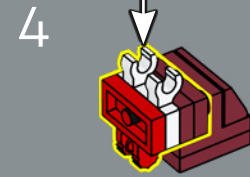
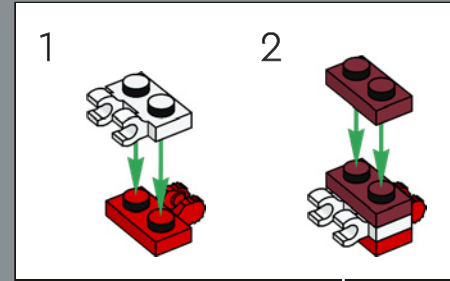
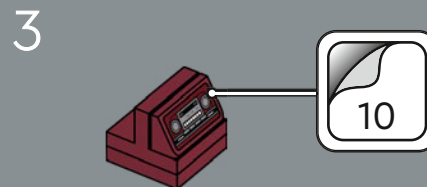
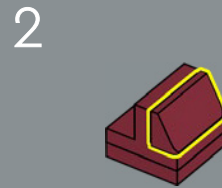
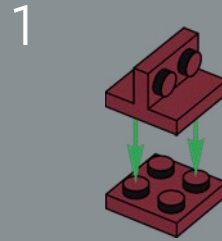

El primer prototipo del Camaro que se construyó, con número de bastidor 10001, existe todavía y está inscrito en el Registro Nacional de Vehículos Históricos de los EE. UU.

49

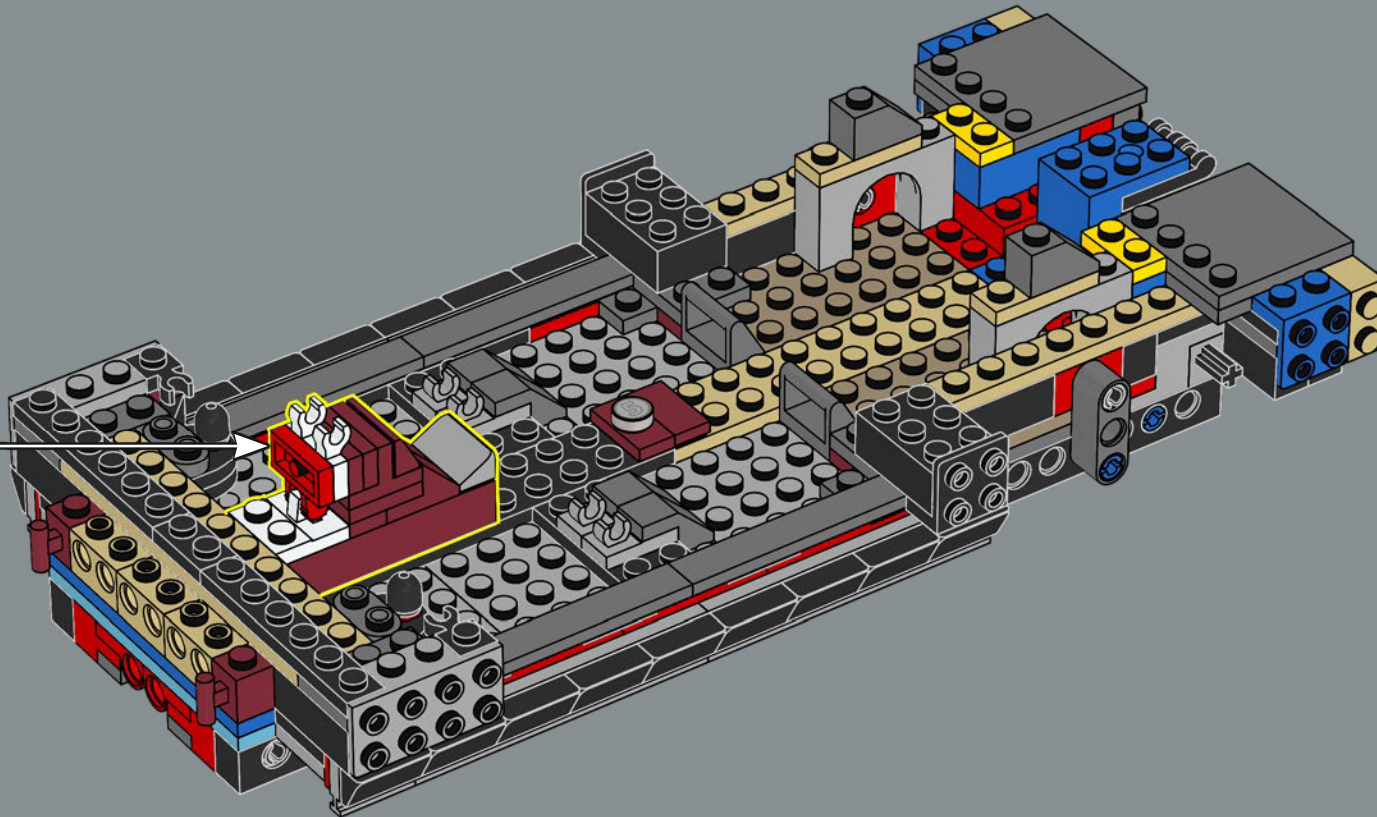

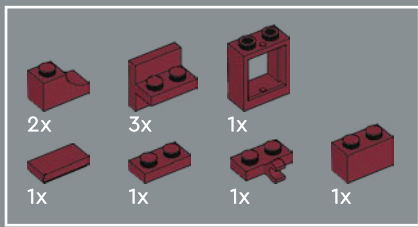

50

1

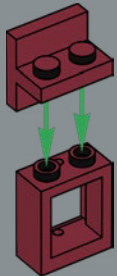

2

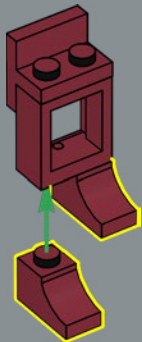

3

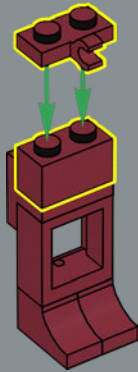

4

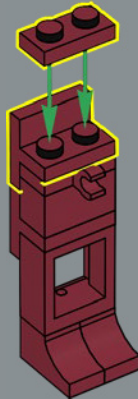

5

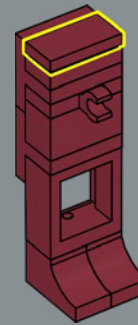

6

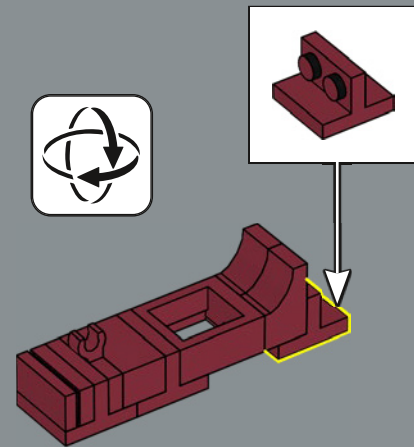

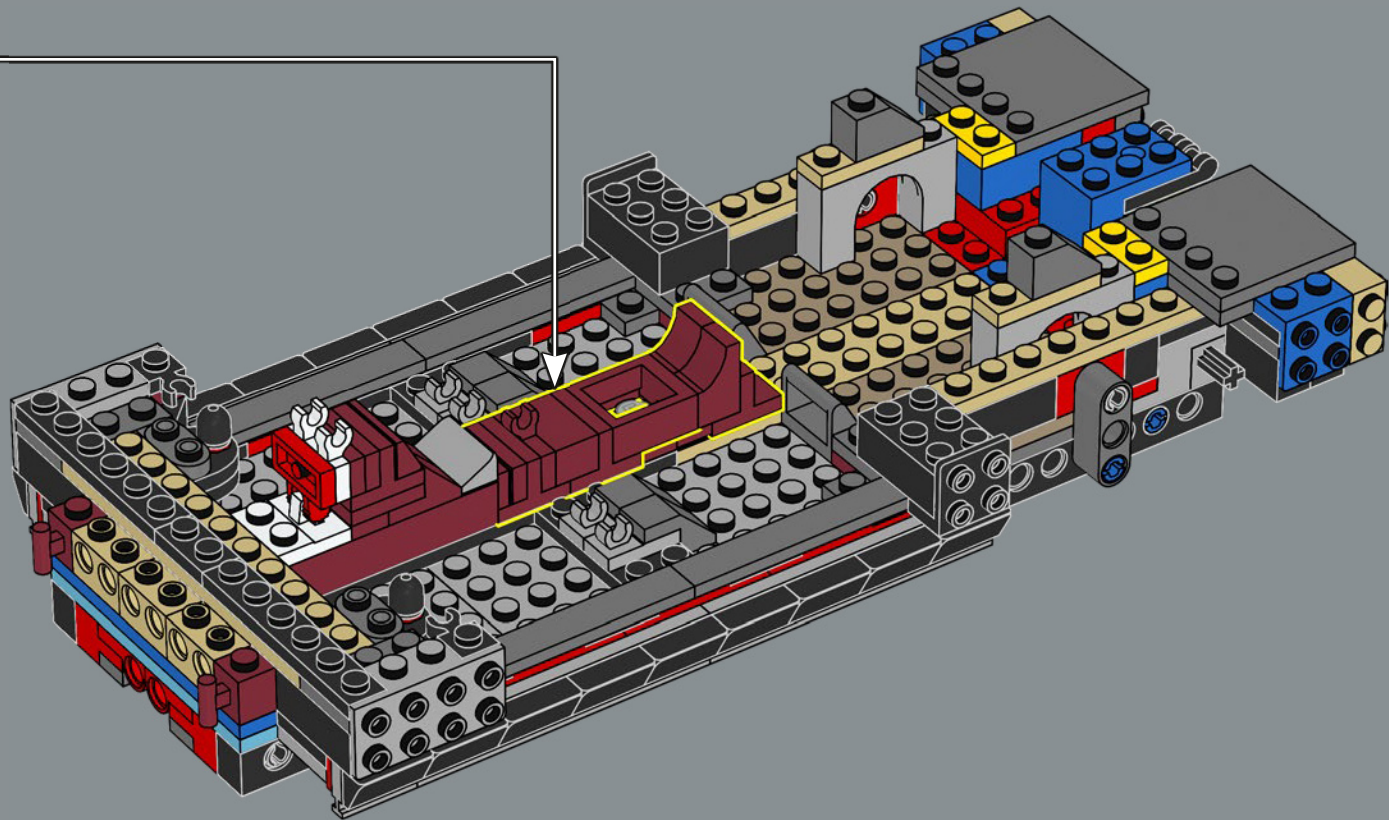

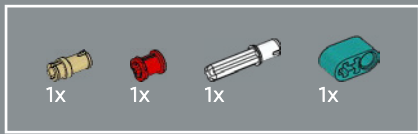

51

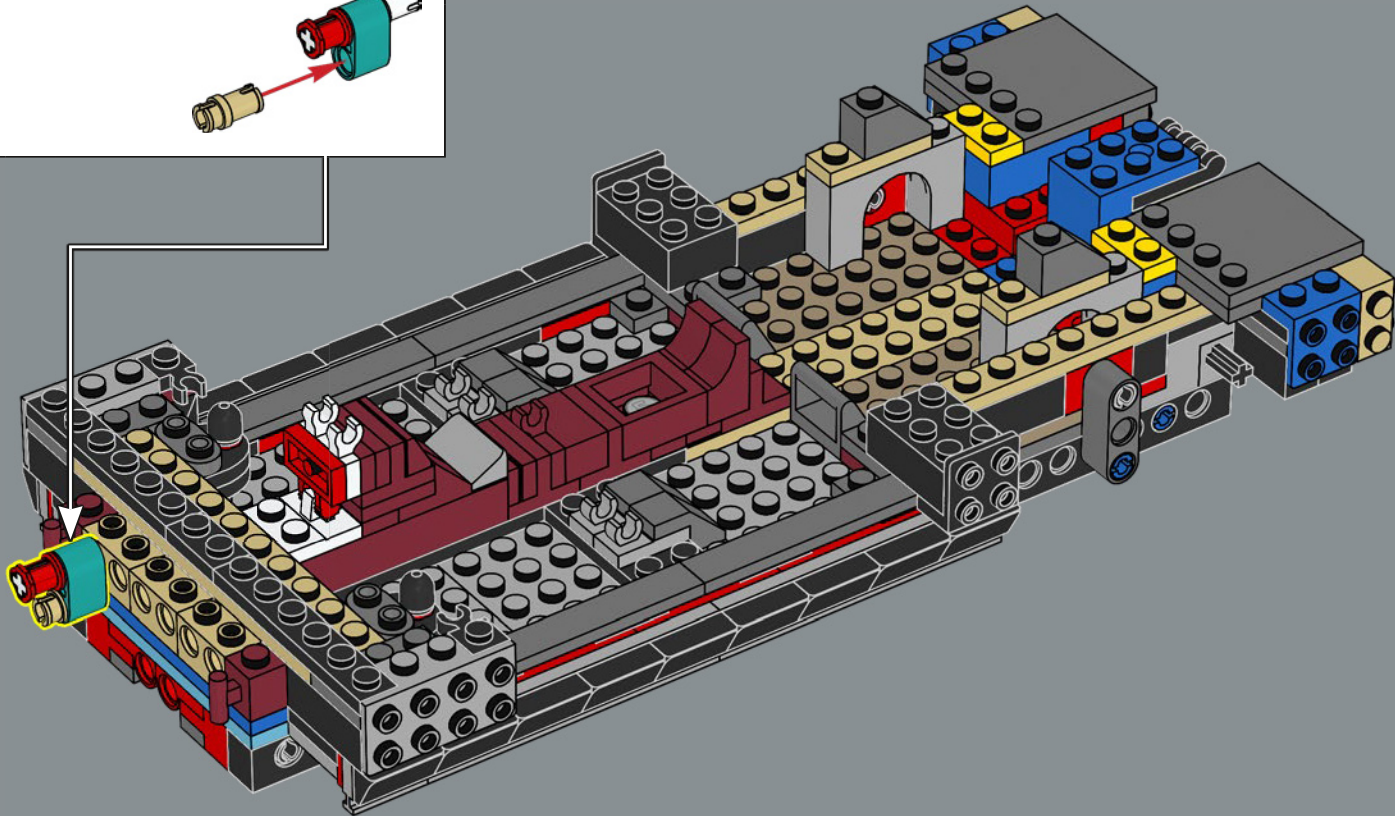
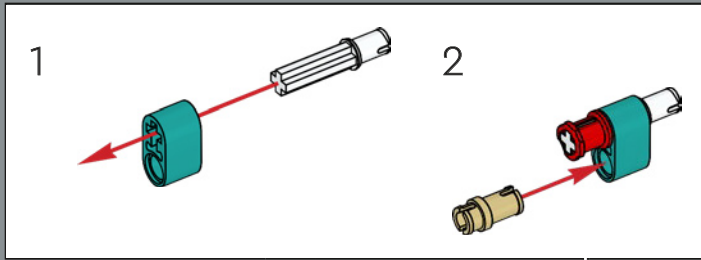

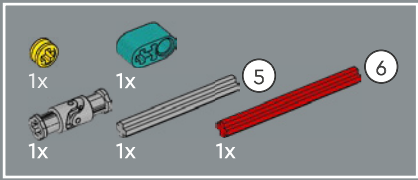

52

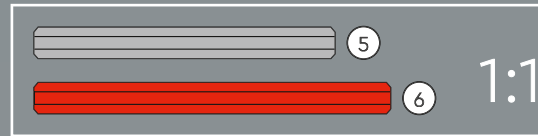
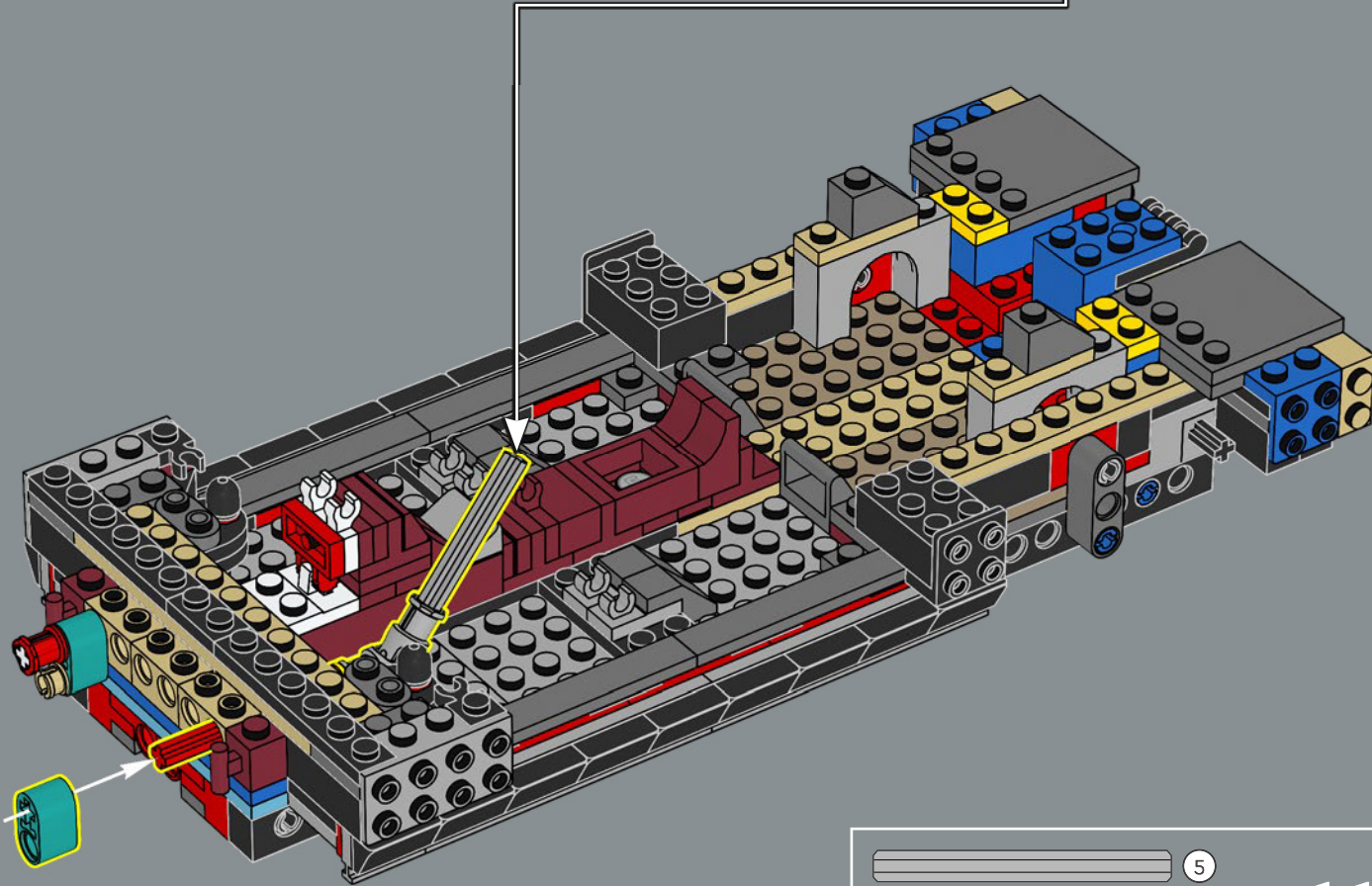
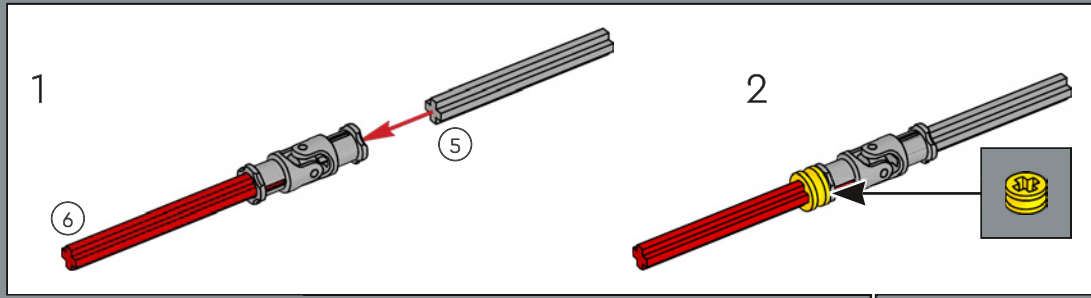



53

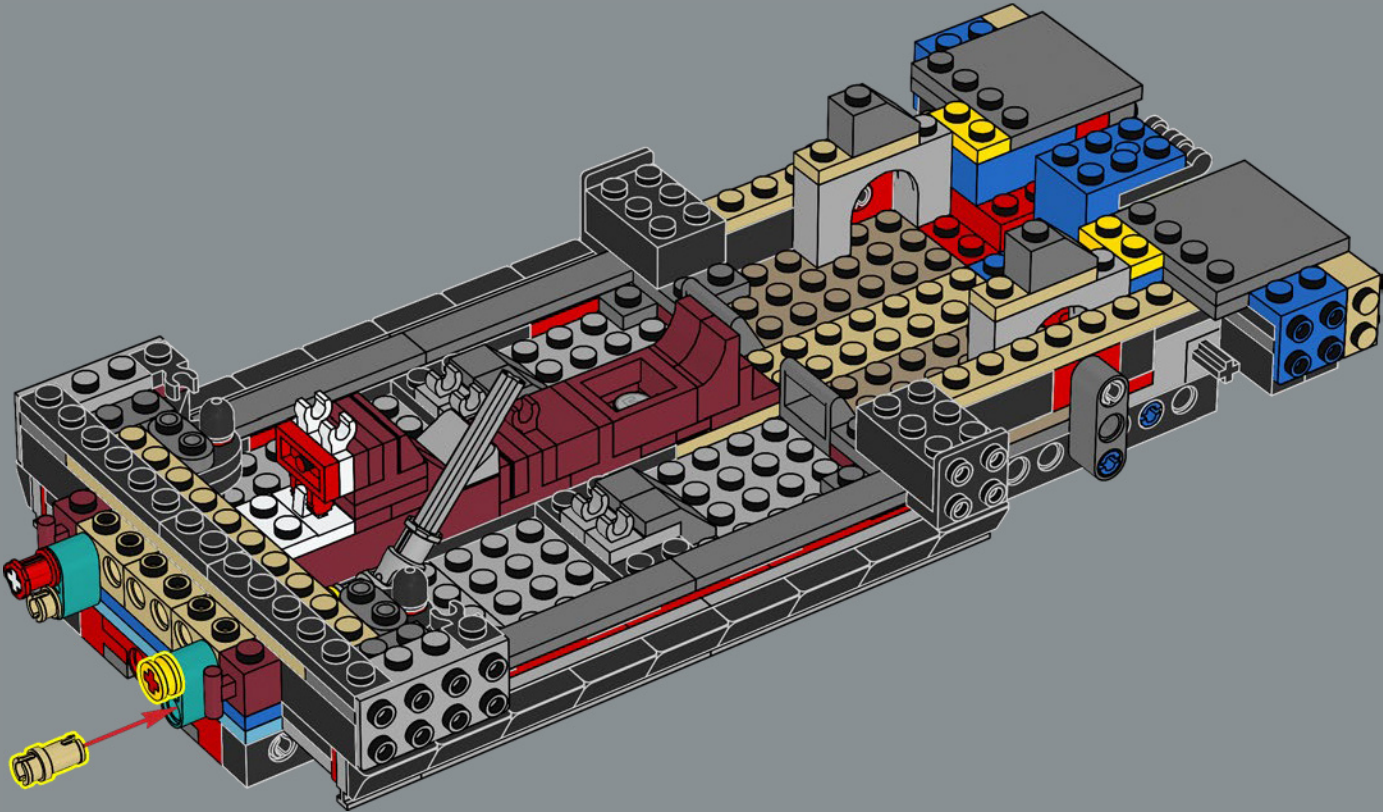

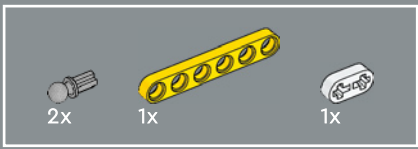

54

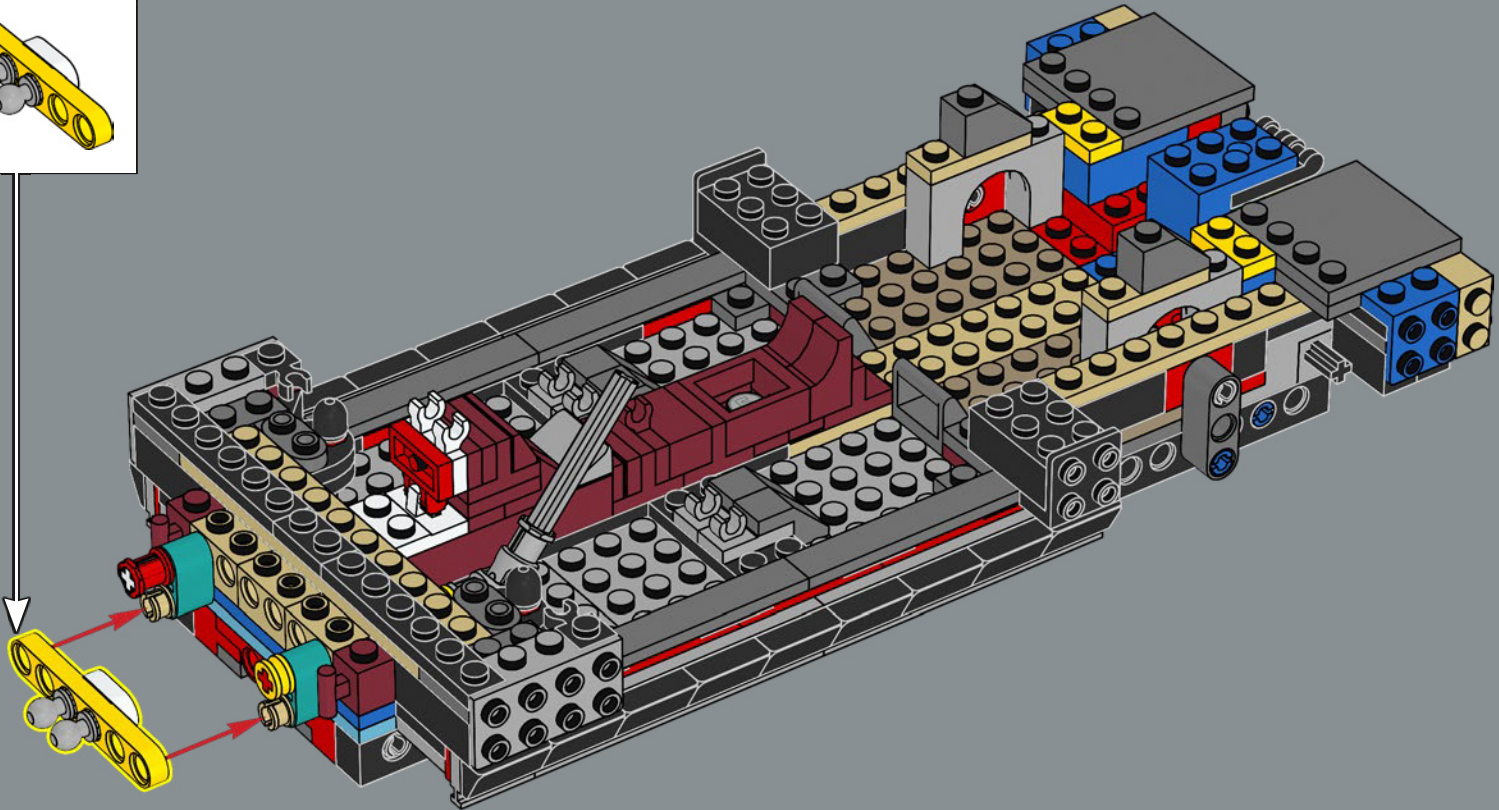
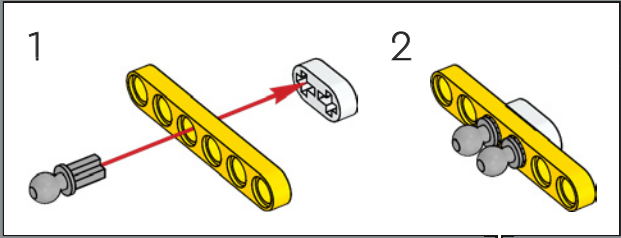

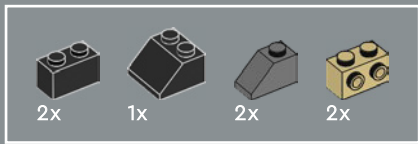

55

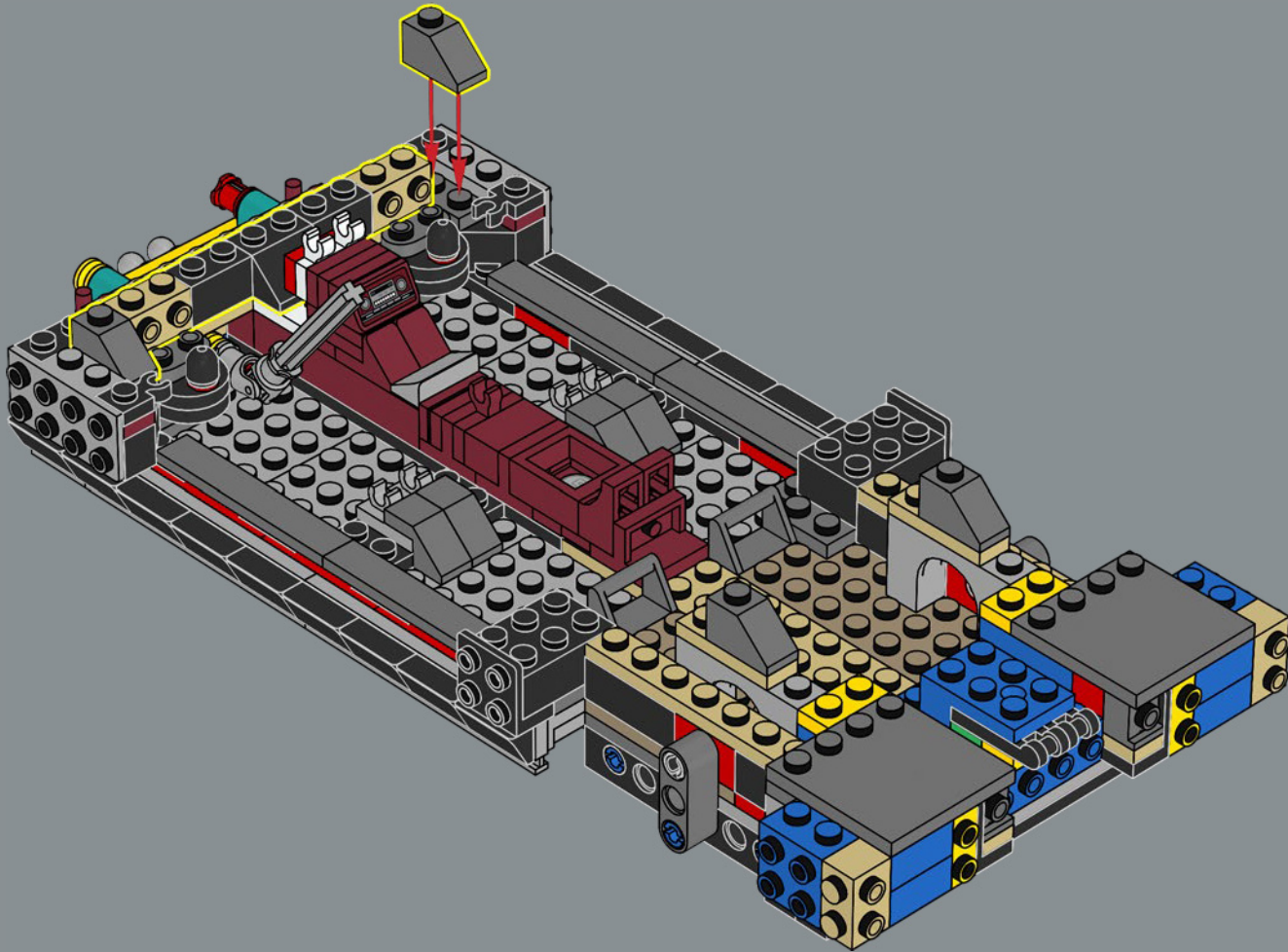

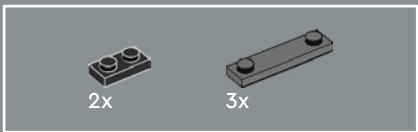

56

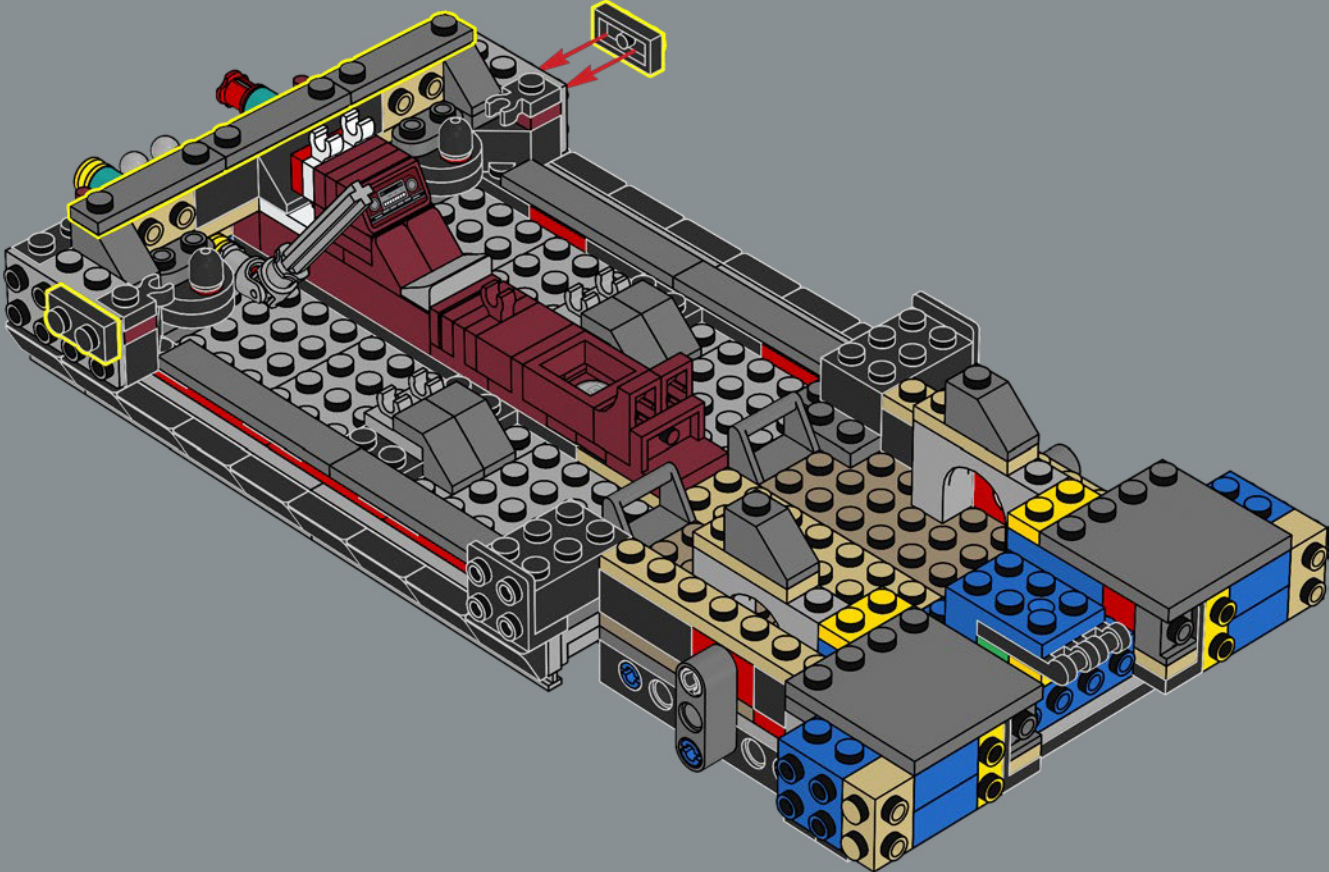

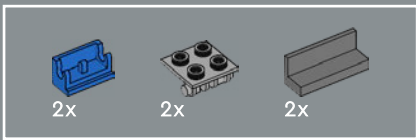

57

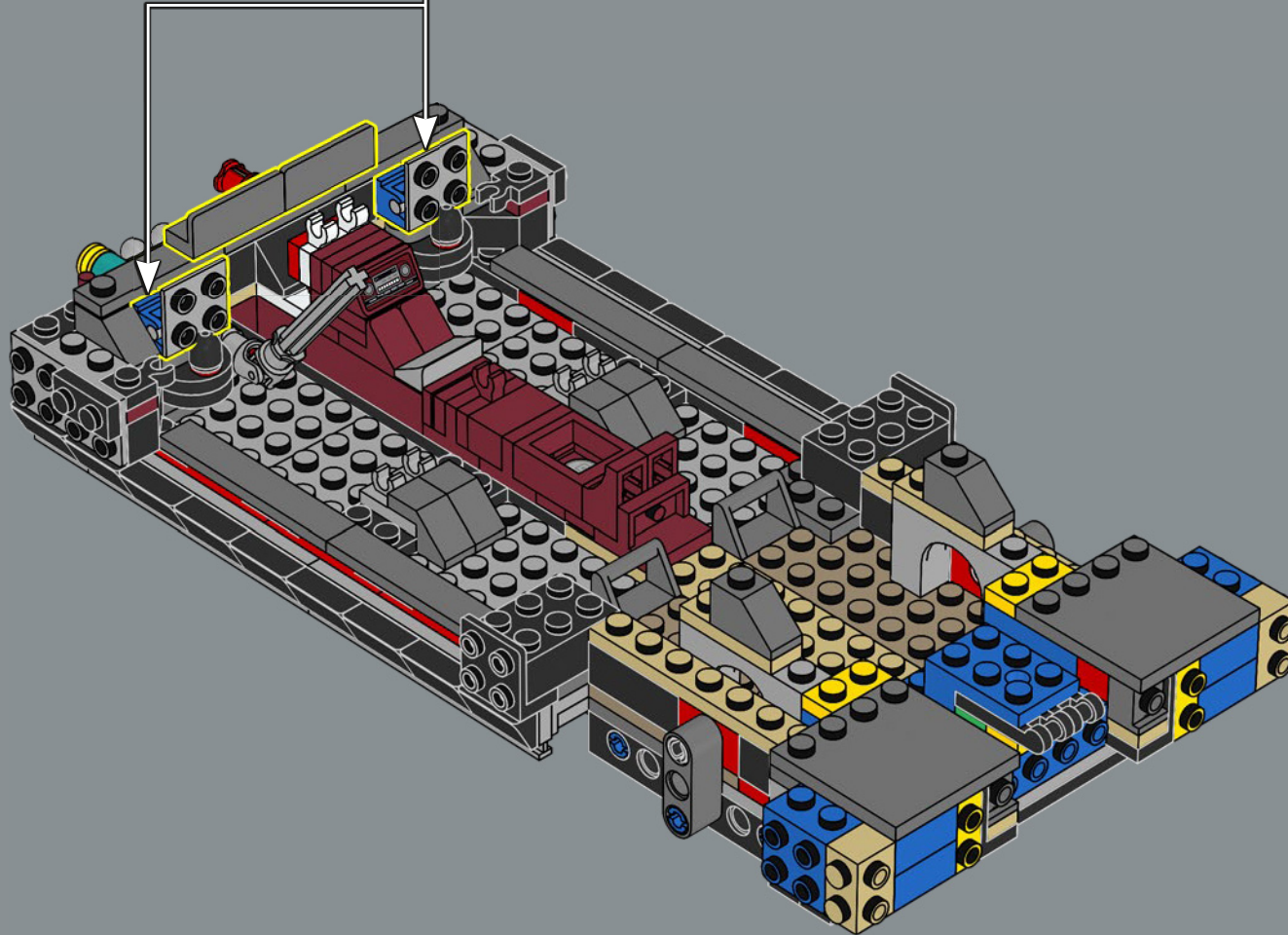
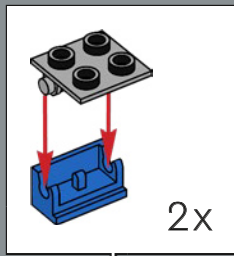



58

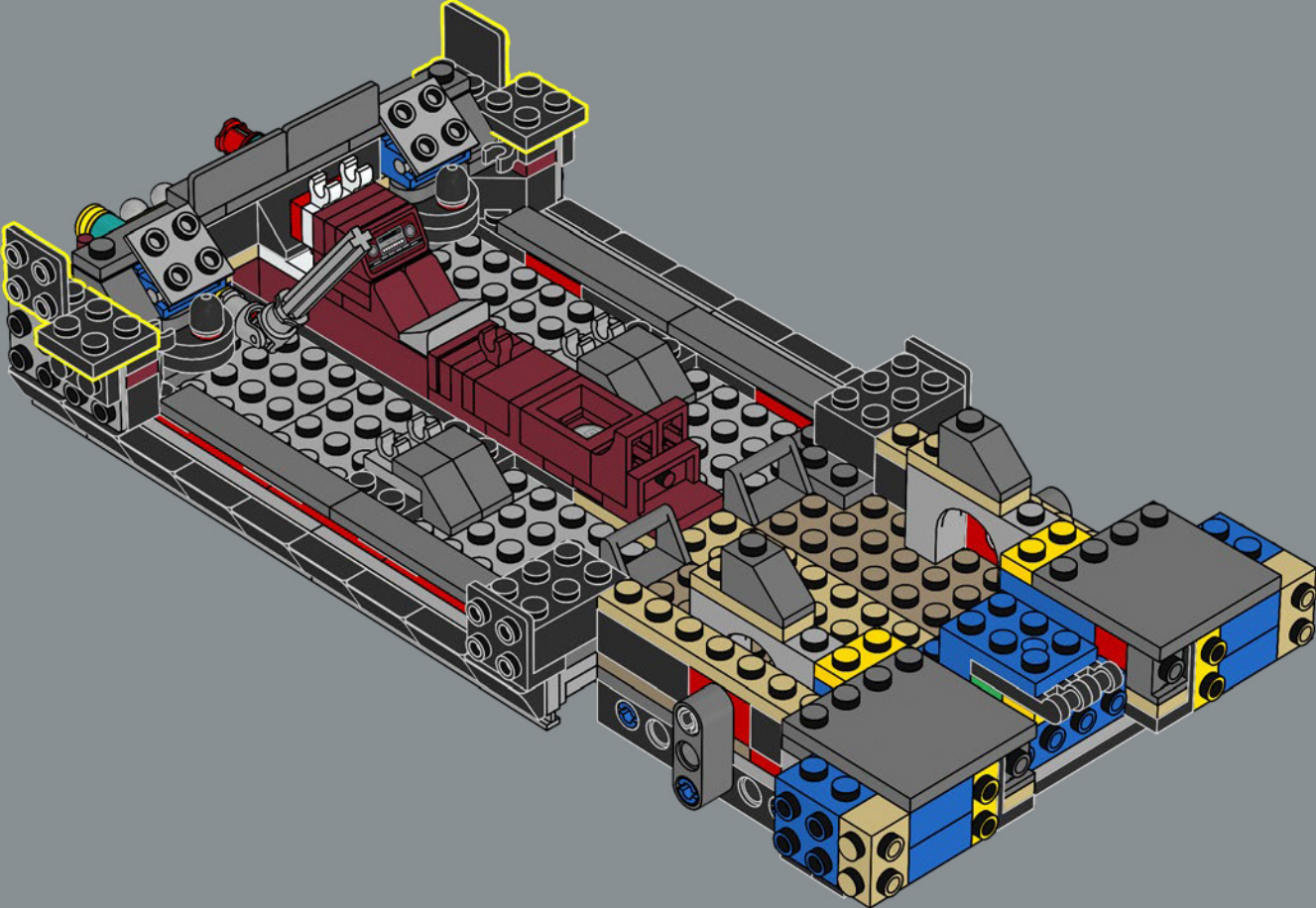

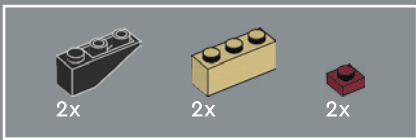

59

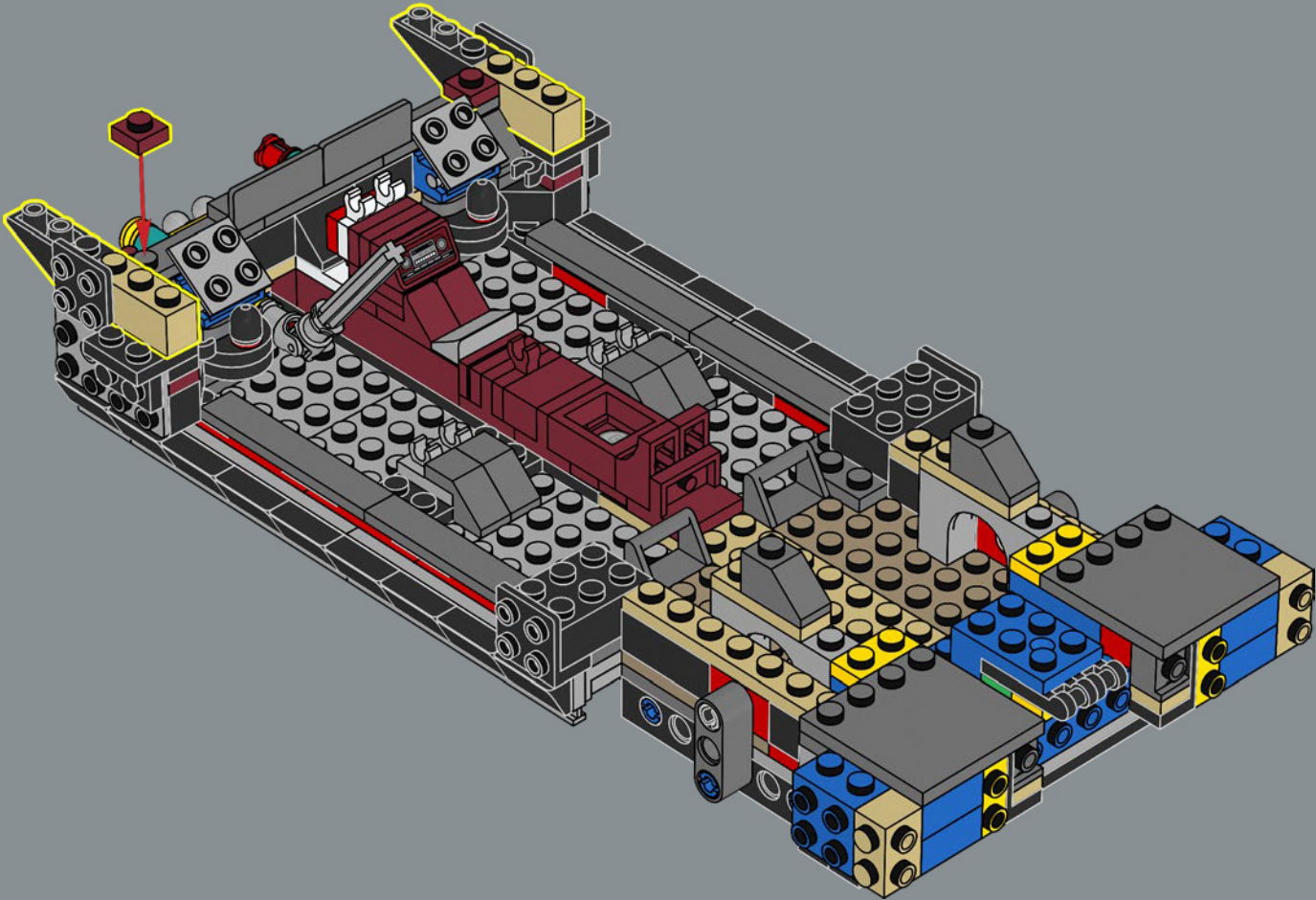



60

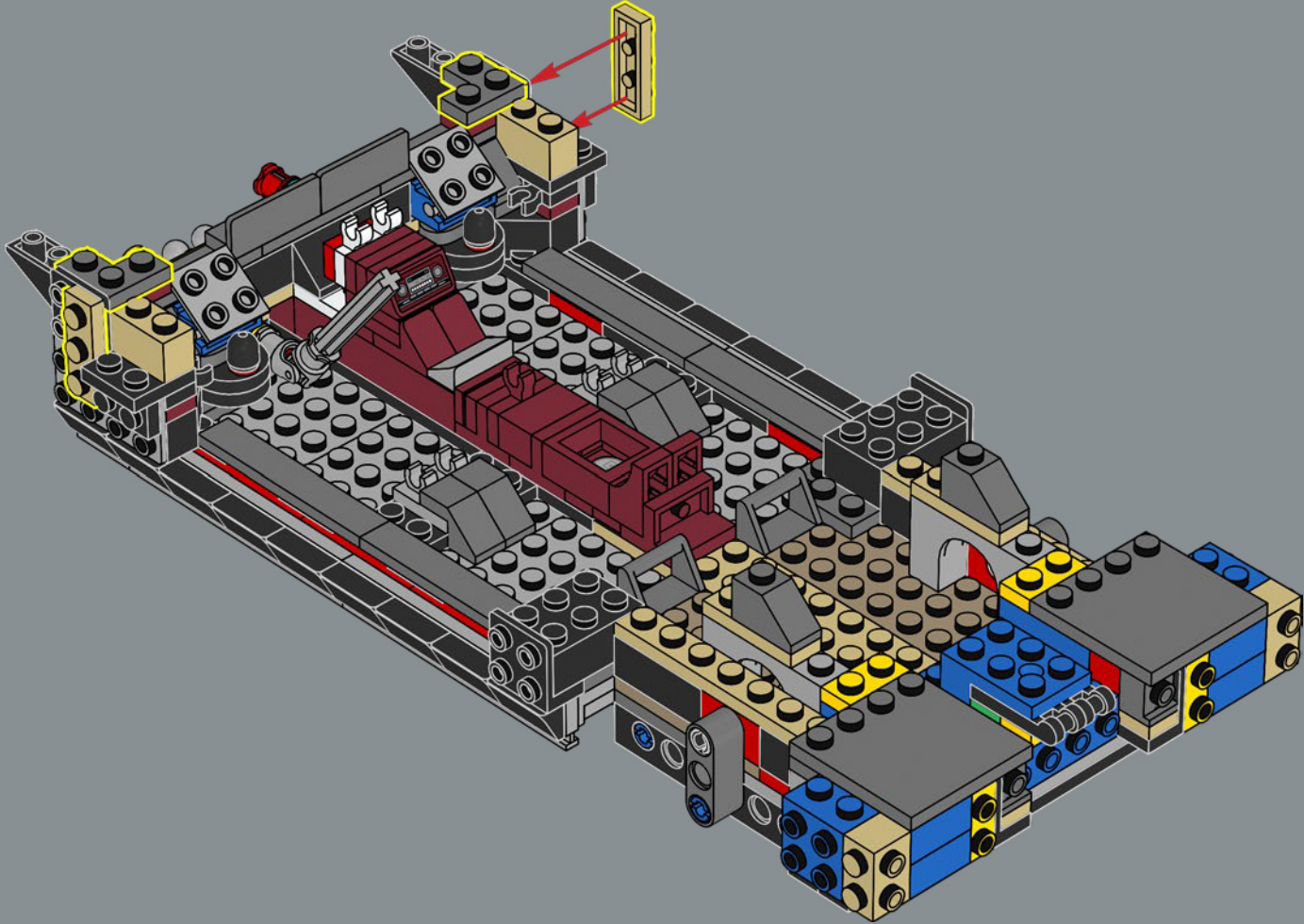

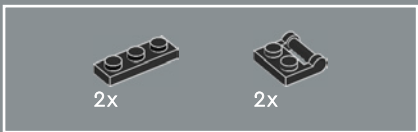

61

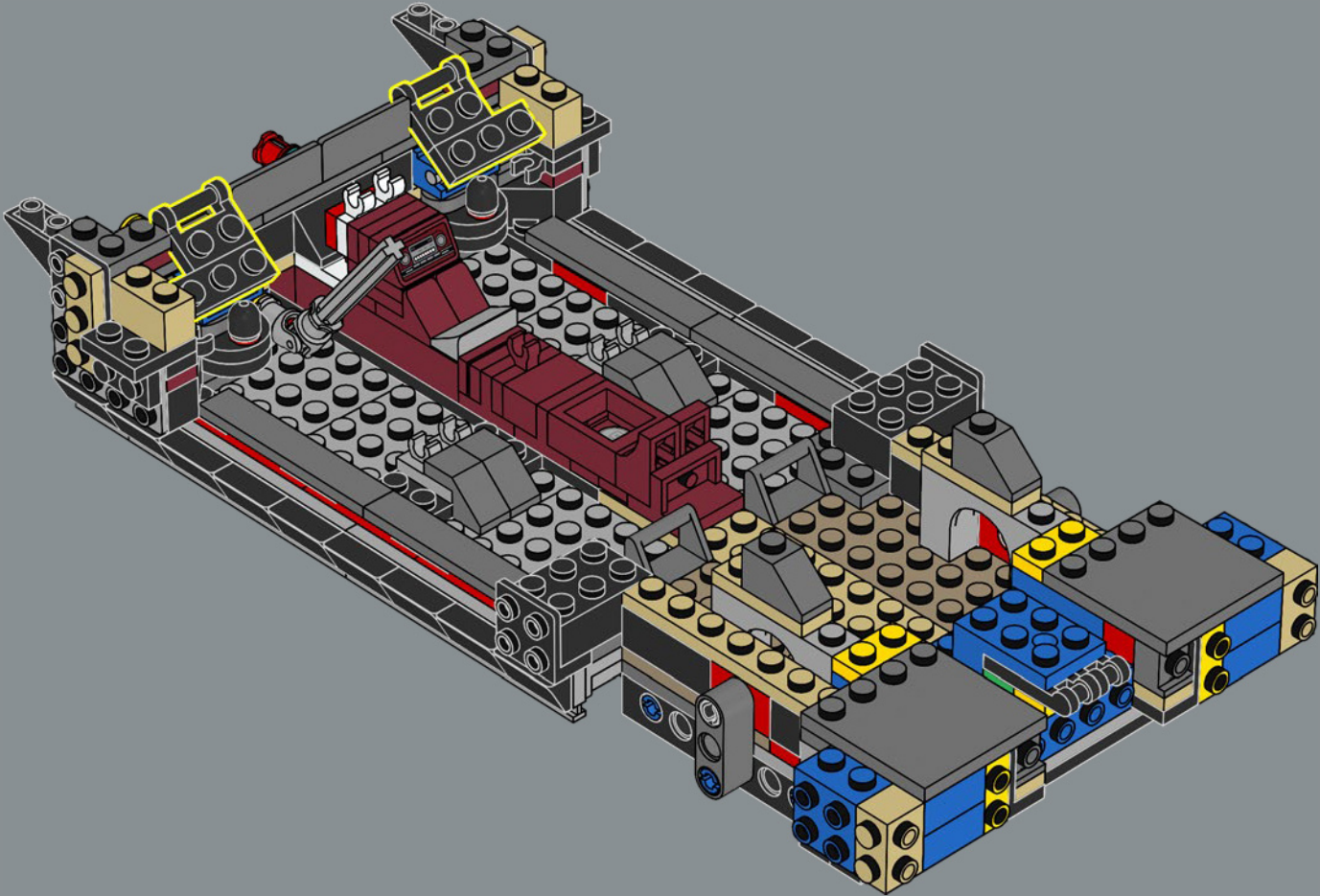

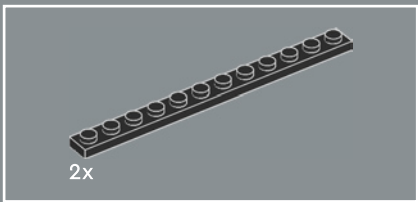

62

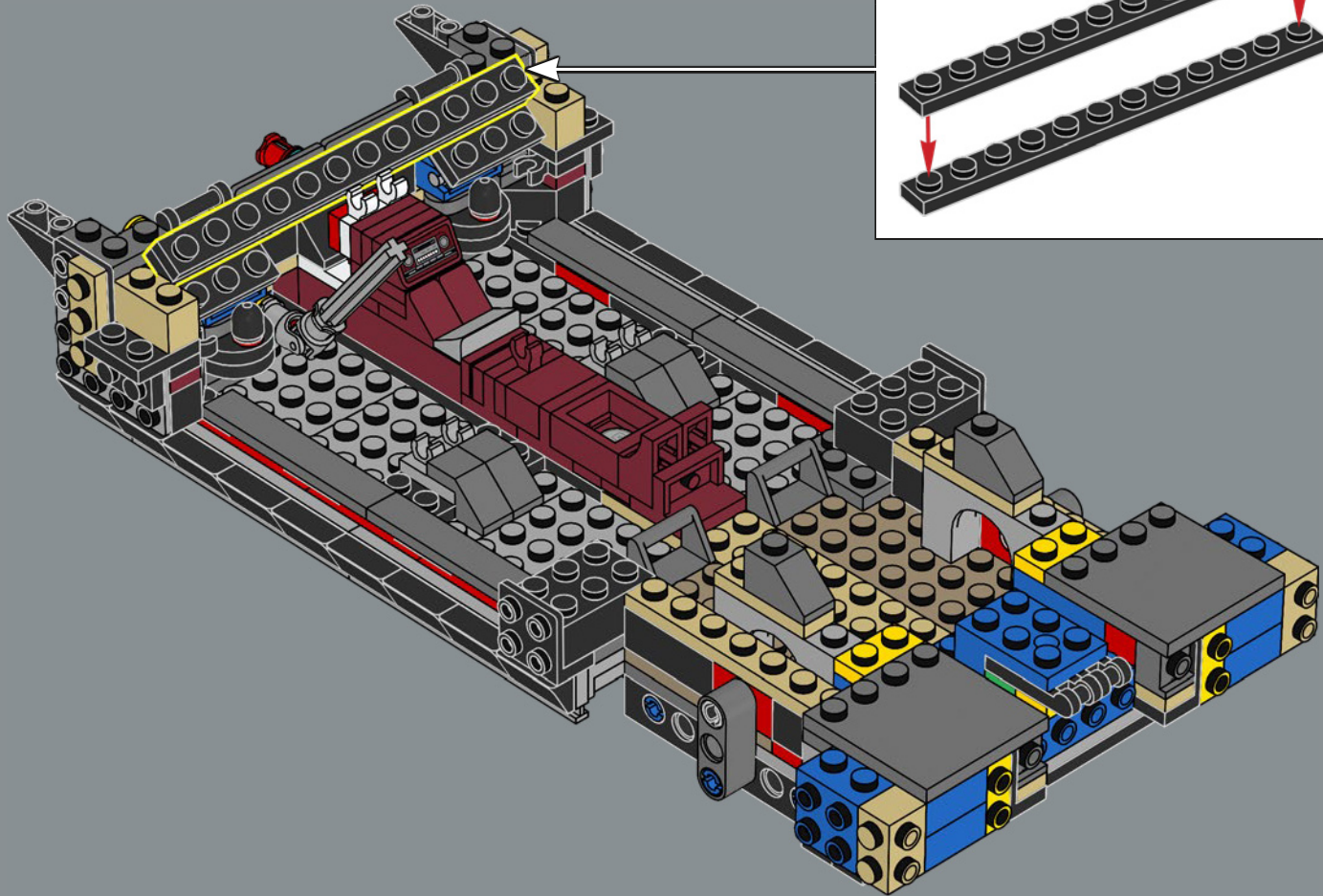

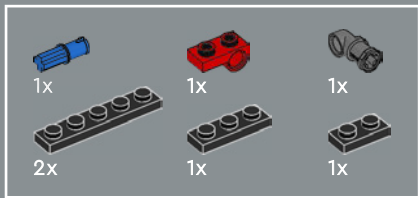

63

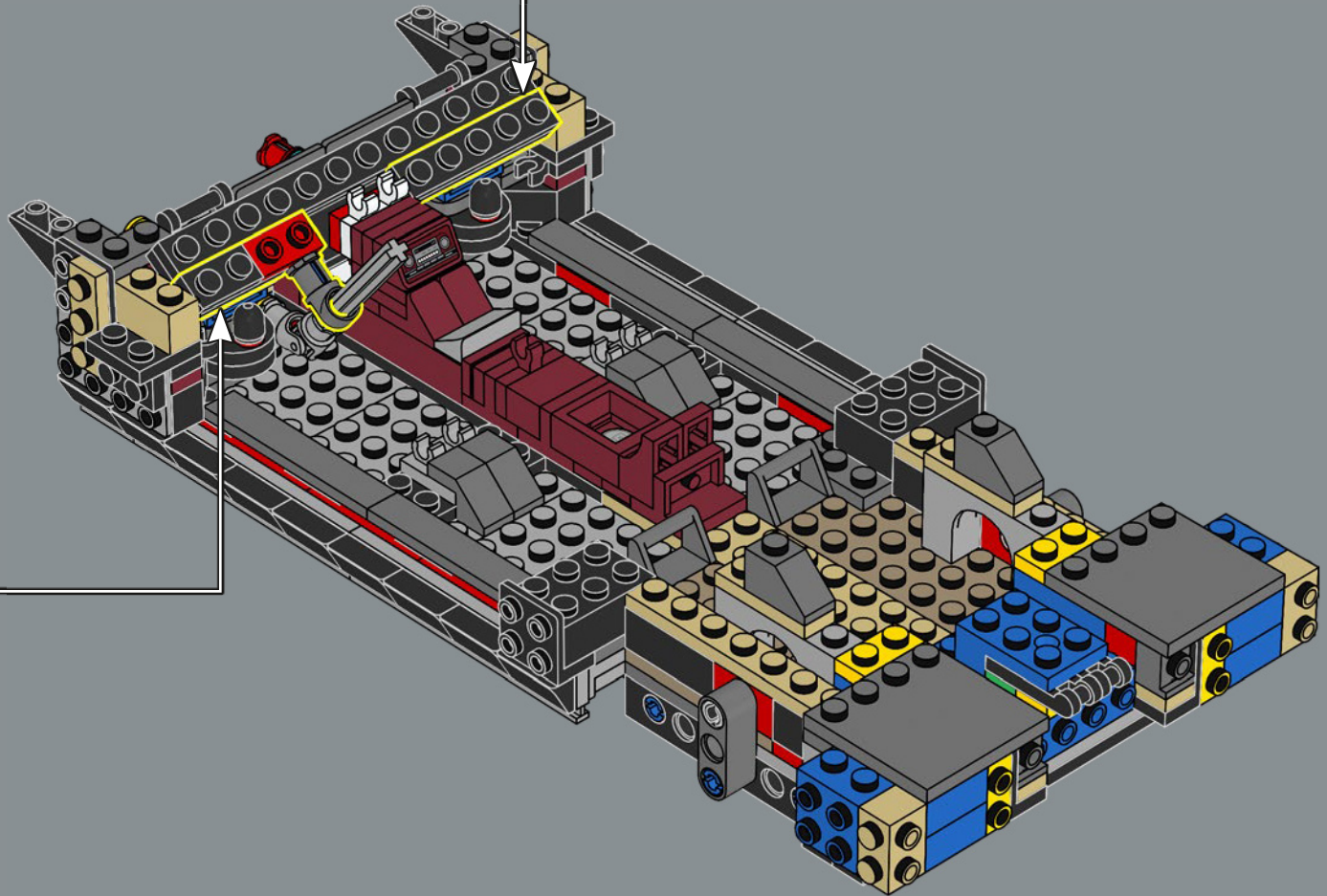
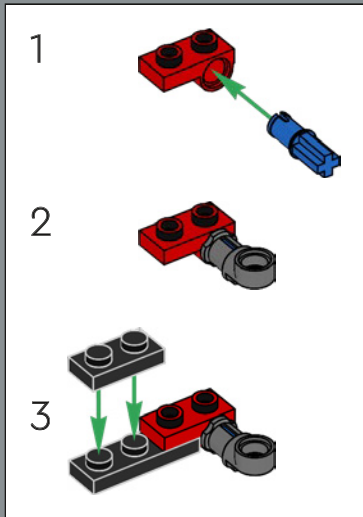
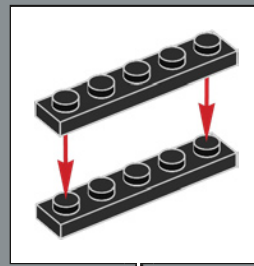

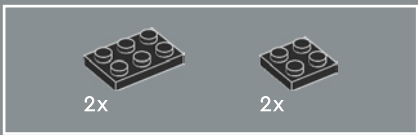

64

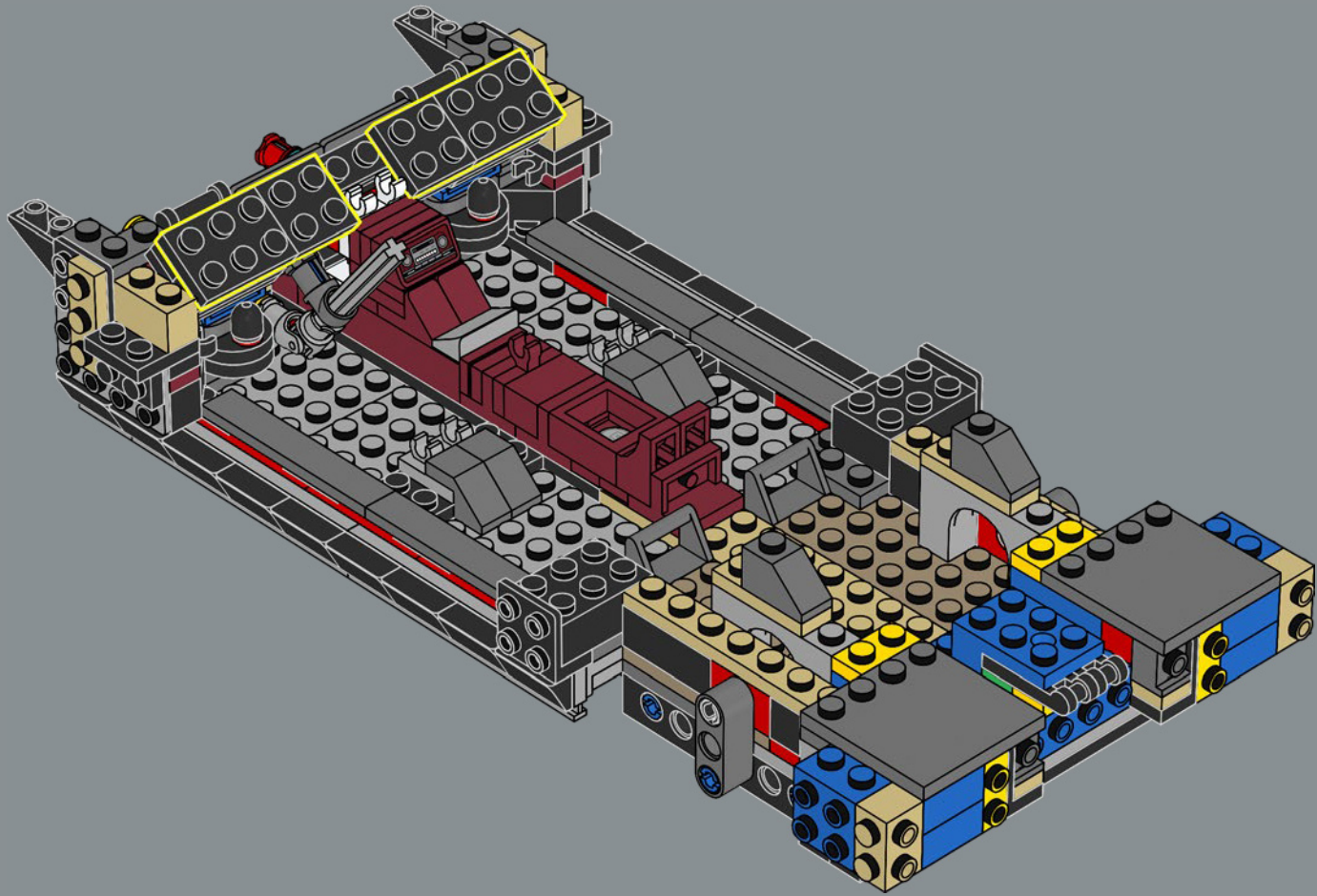



65

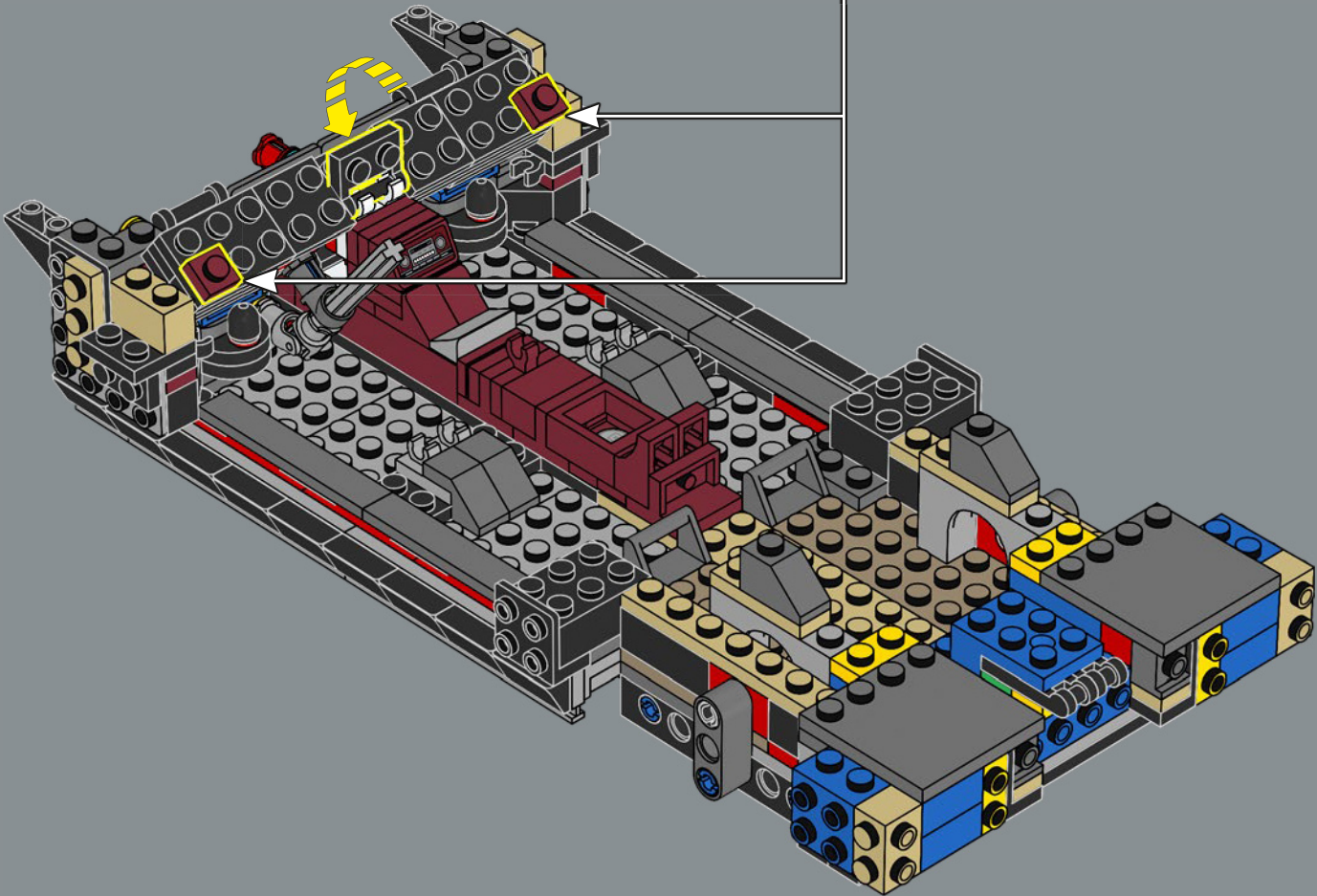
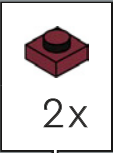

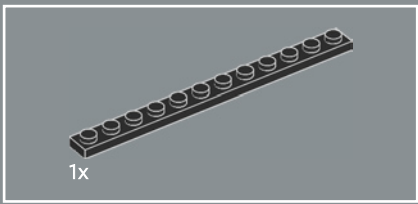

66

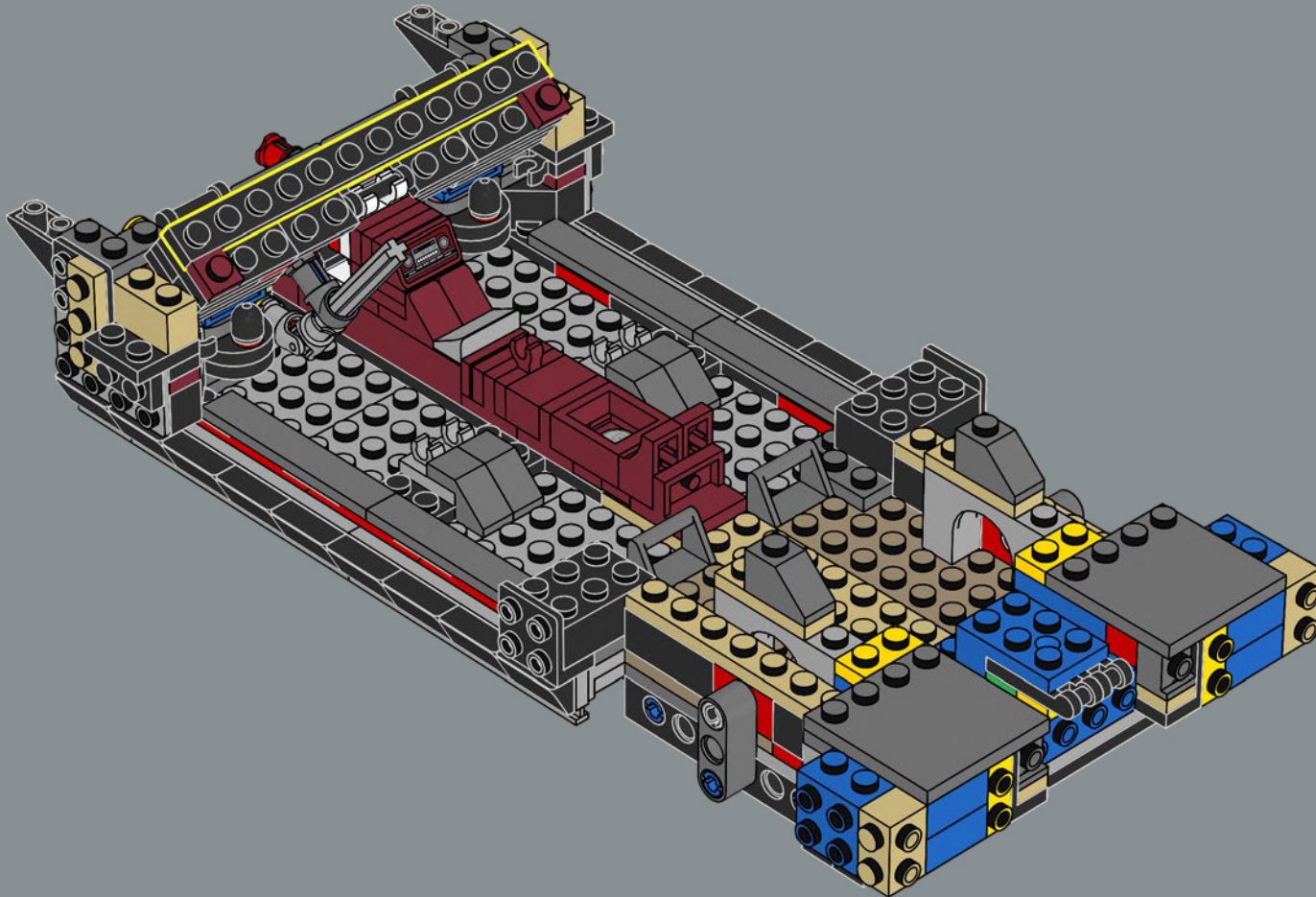

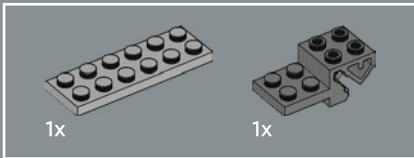
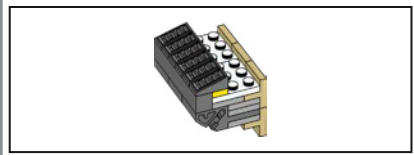

67

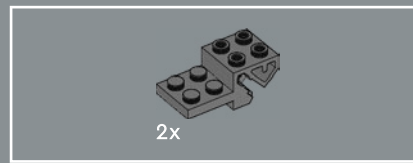
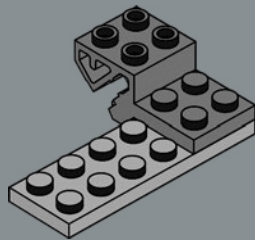

68

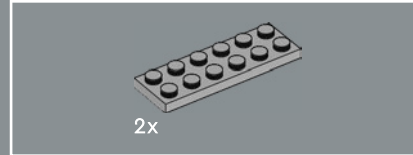
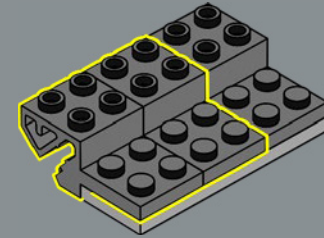

69

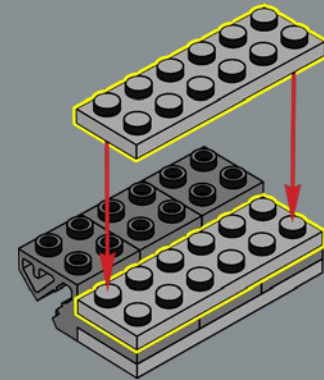

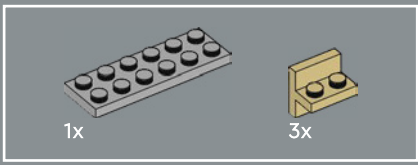

70

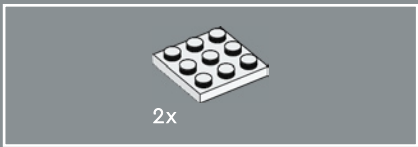
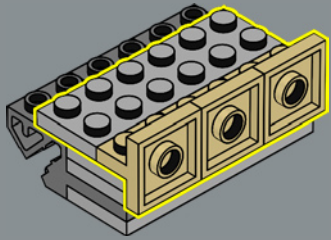

71

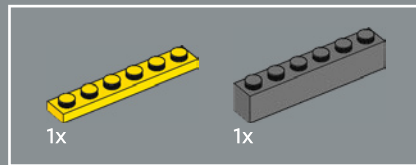
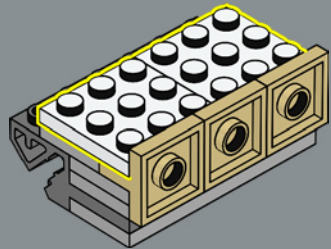

72

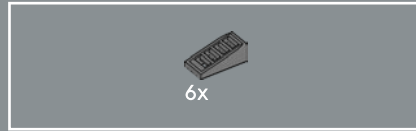
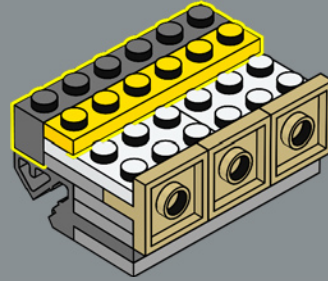

73

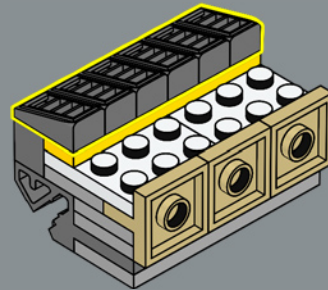

74

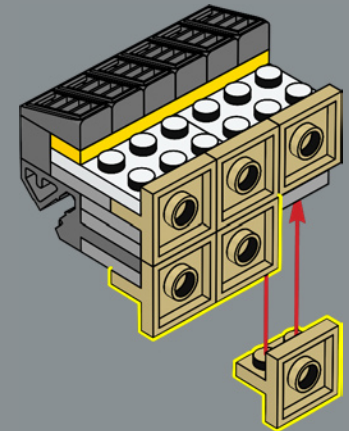

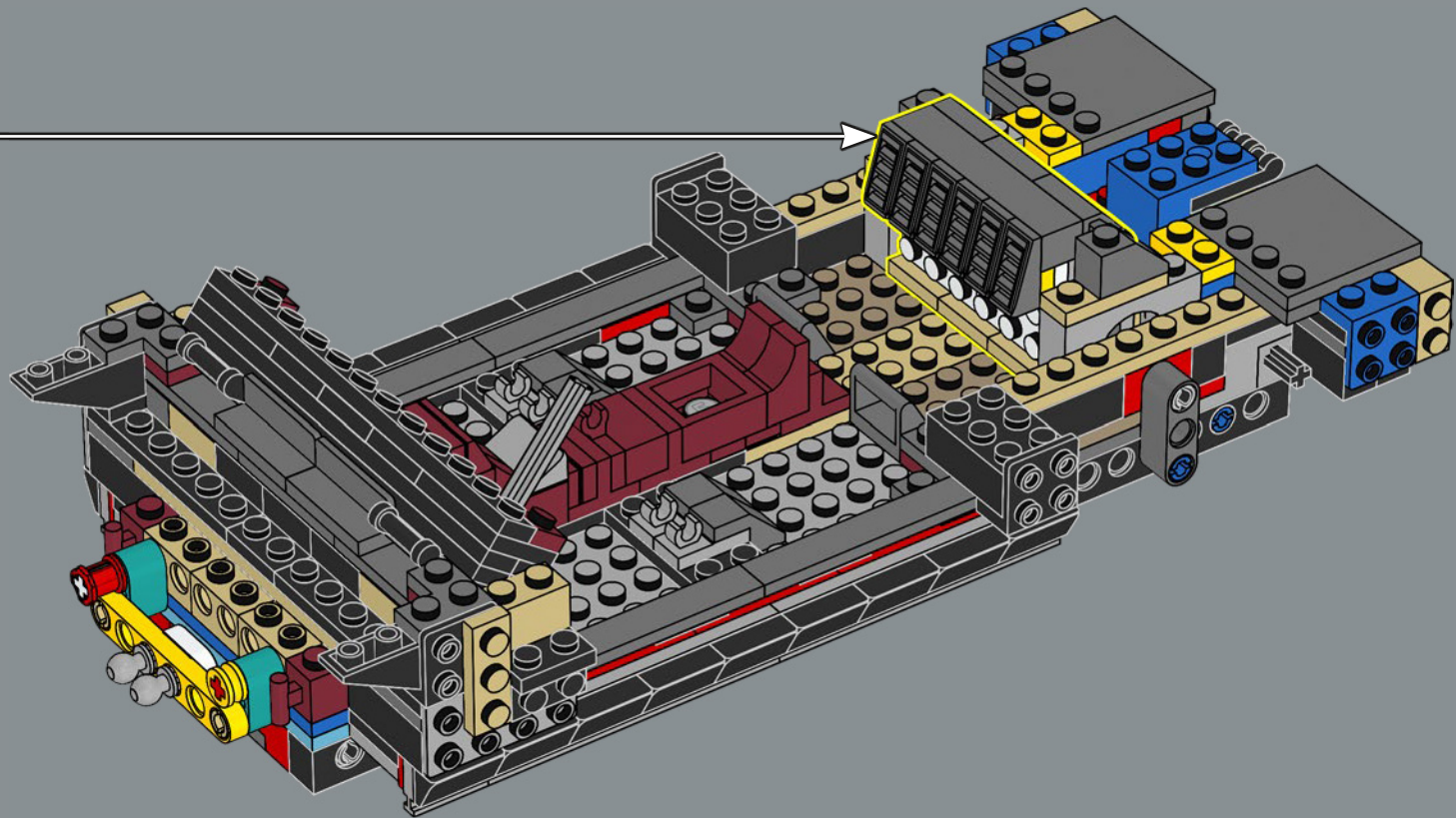

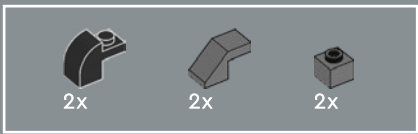

76

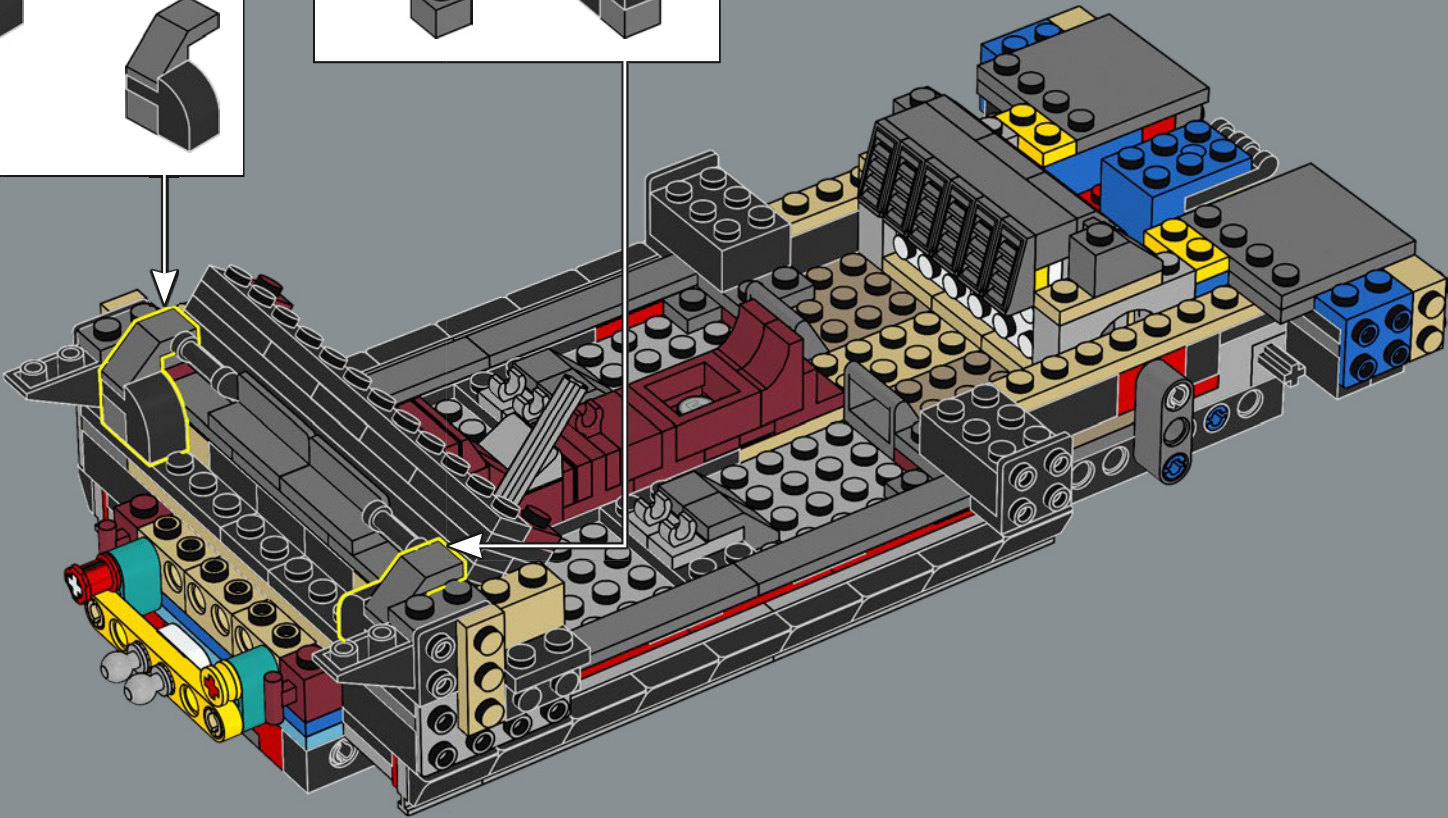
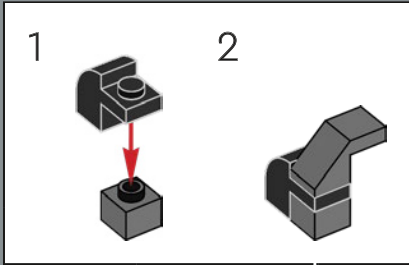
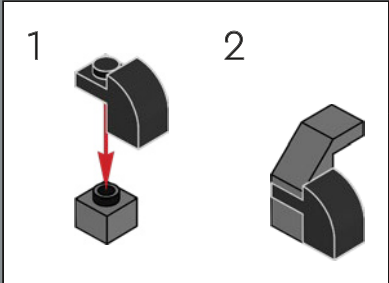

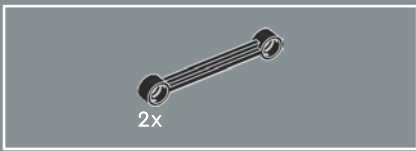

Se usó un Camaro Z11 descapotable especial como coche de seguridad oficial en las 500 Millas de Indianápolis de 1969.

77

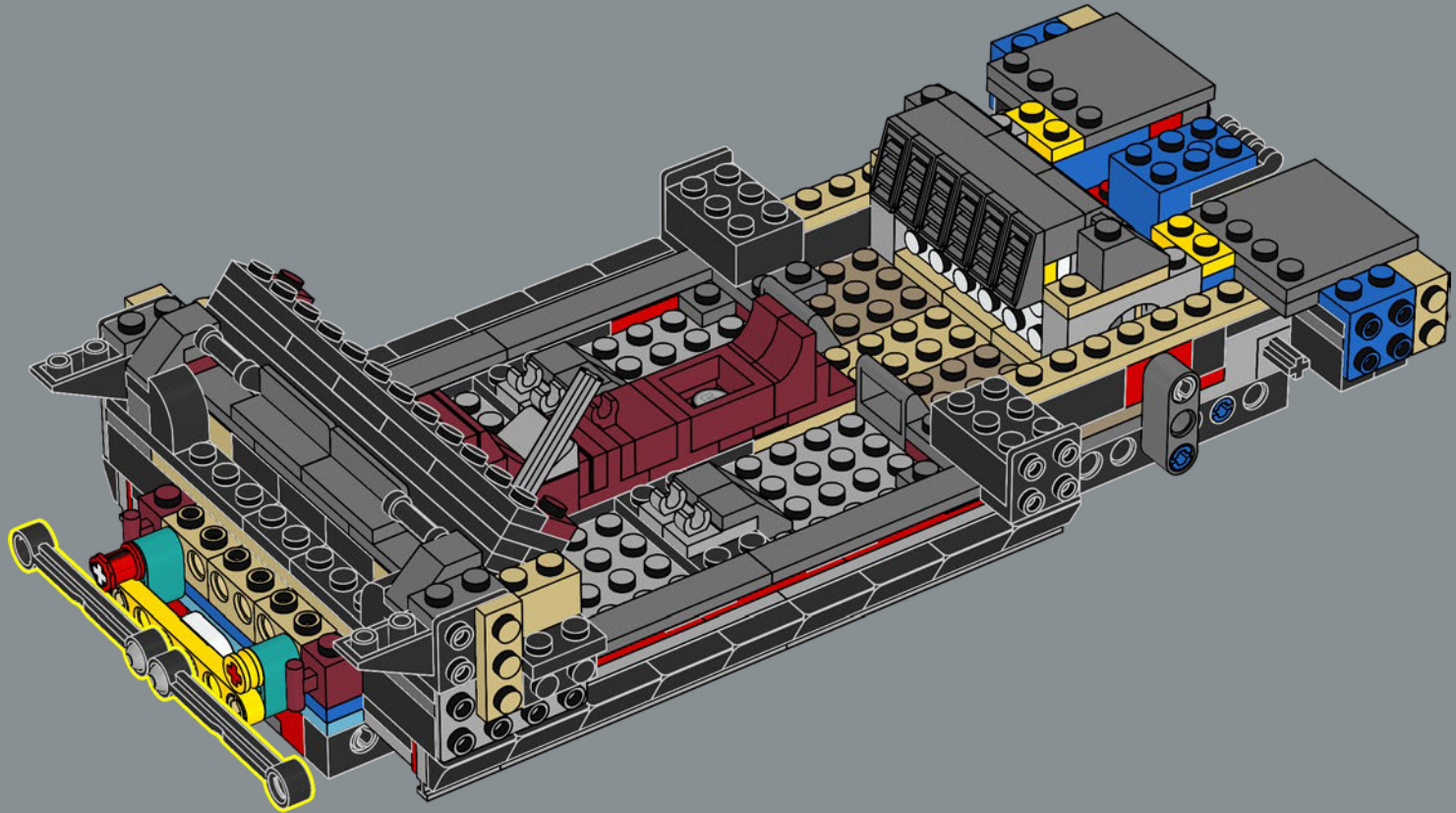

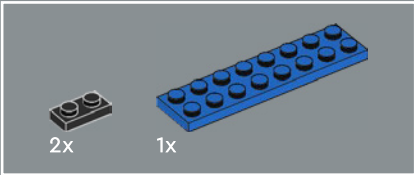
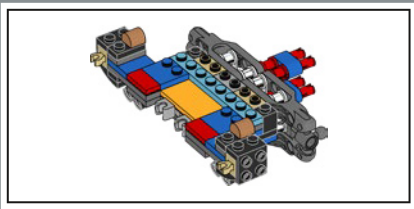

78

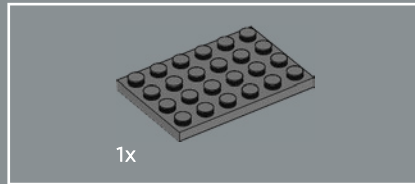
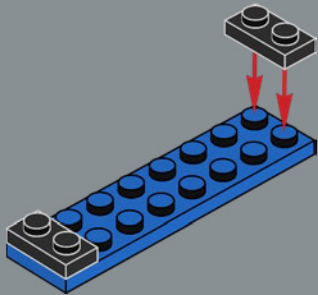

79

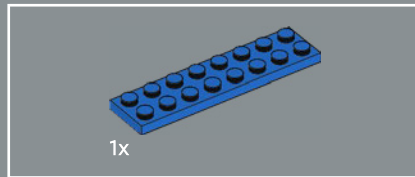
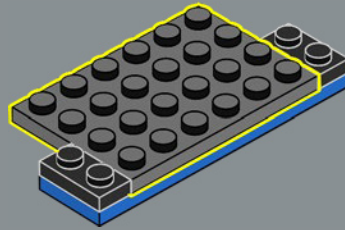

80

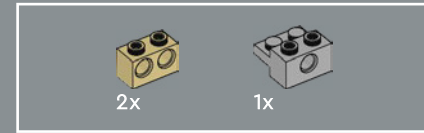
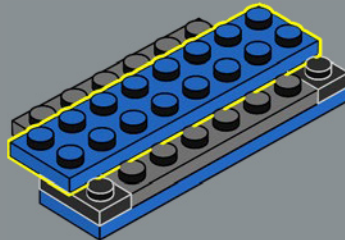

81

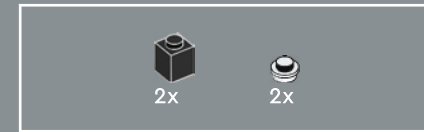
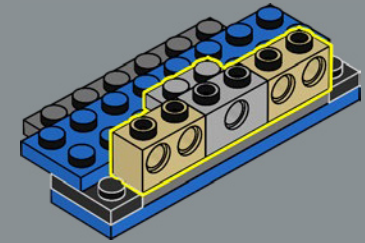

82

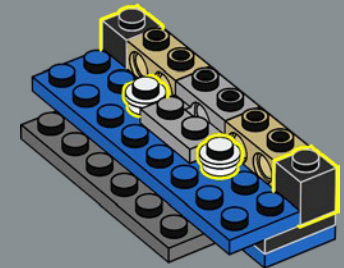



83

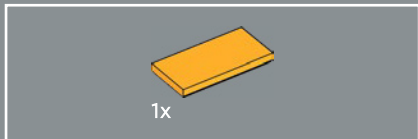
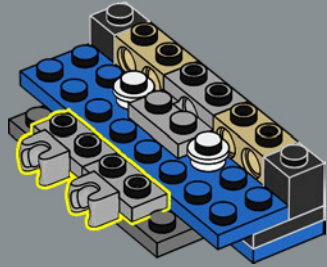

84

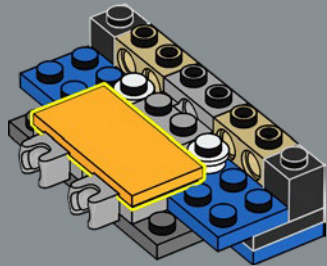

85

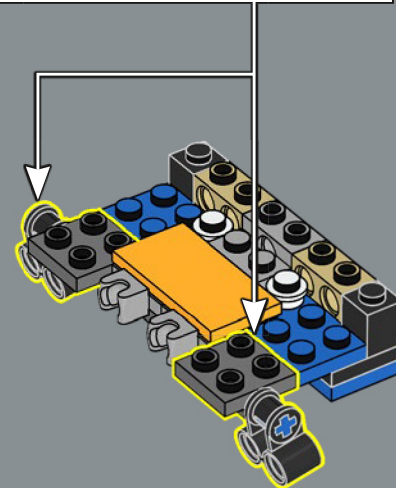
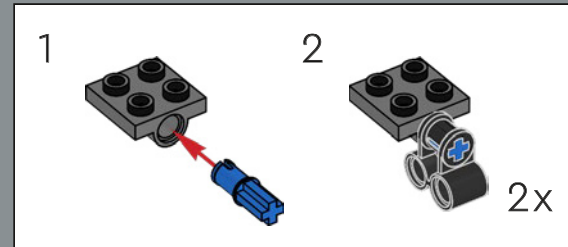

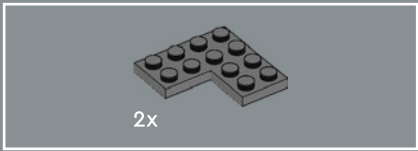

86

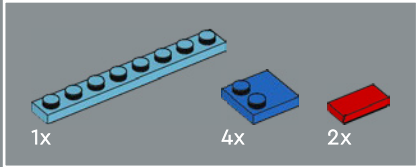
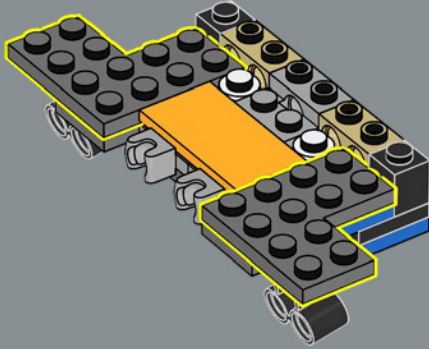

87

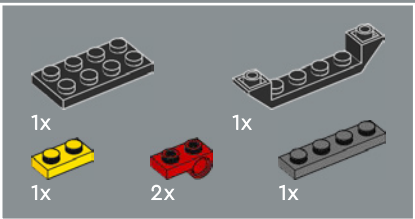
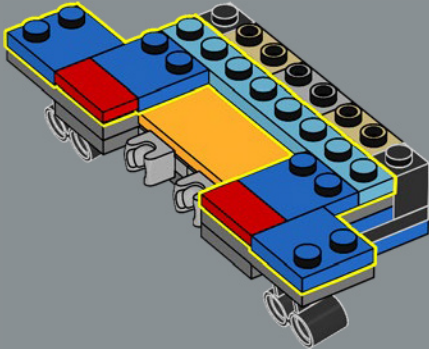

88

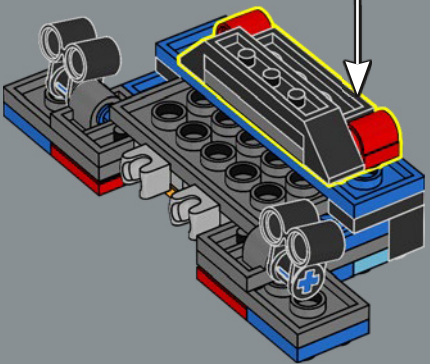
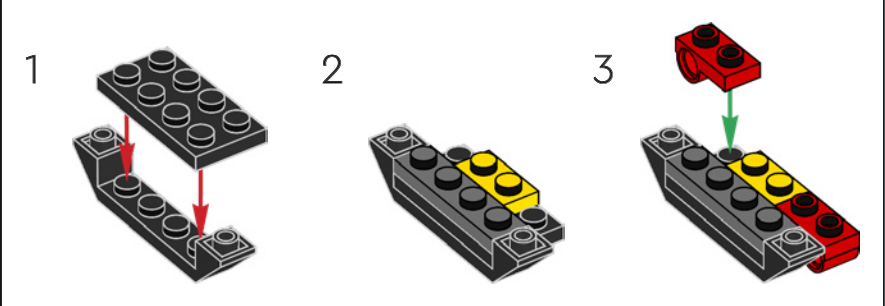

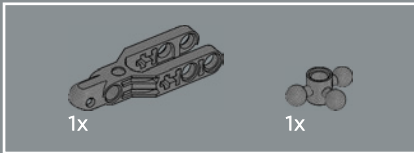
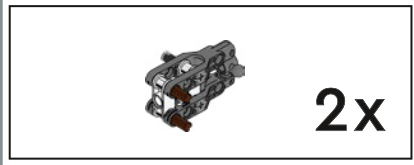
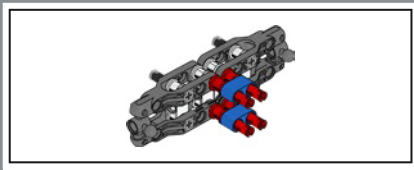

89

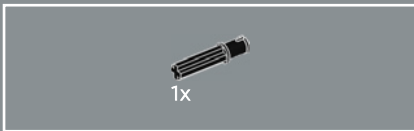
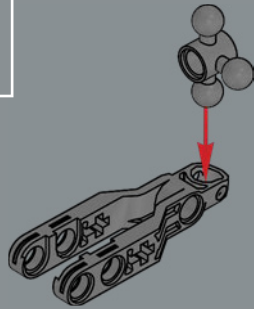

90

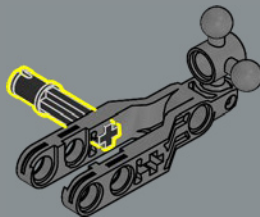

91

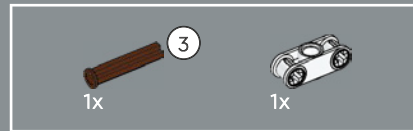
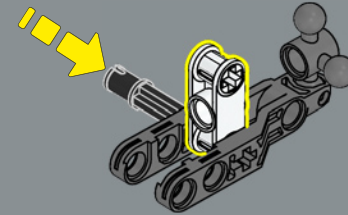

92

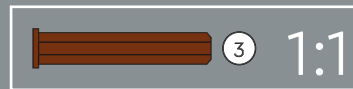
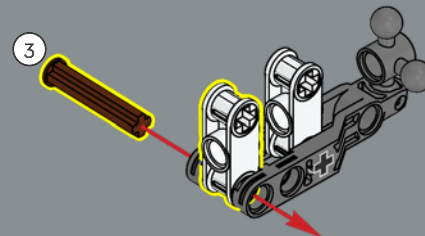



93

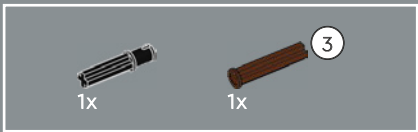
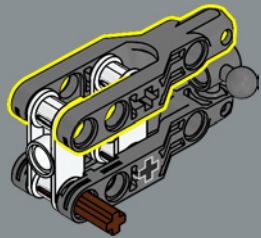

94

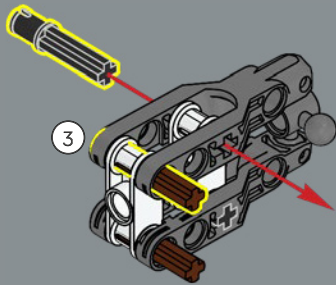

2x

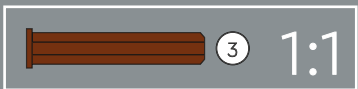

95

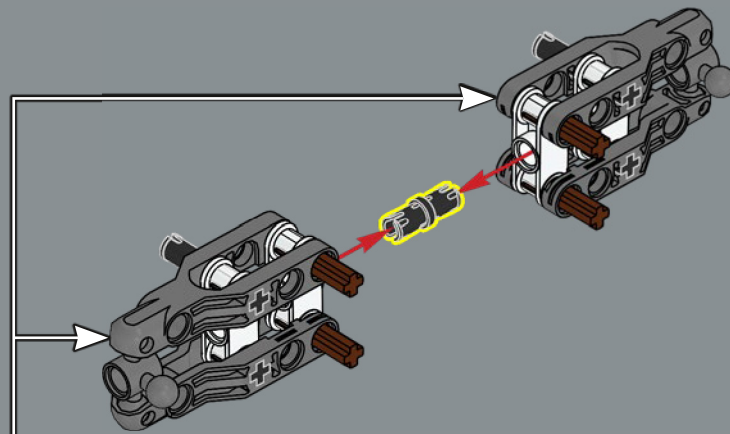



96

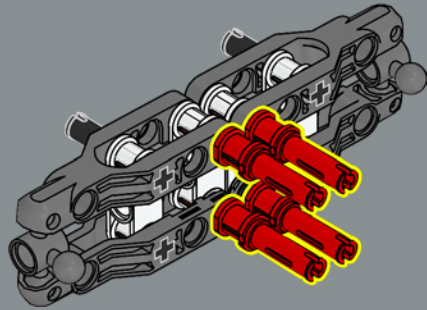

97

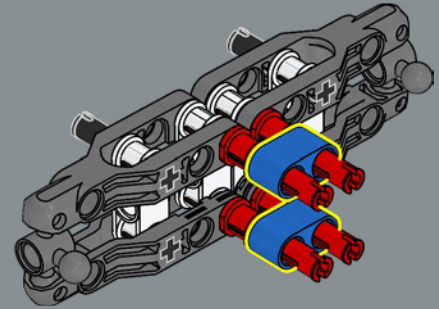

98

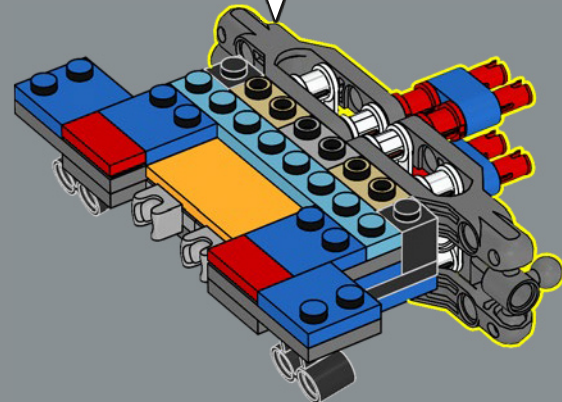

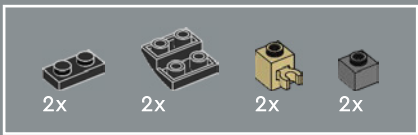

99

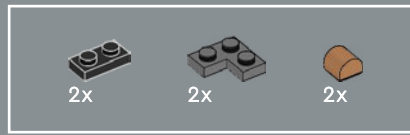
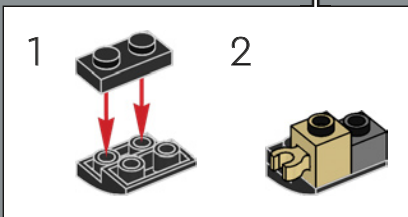
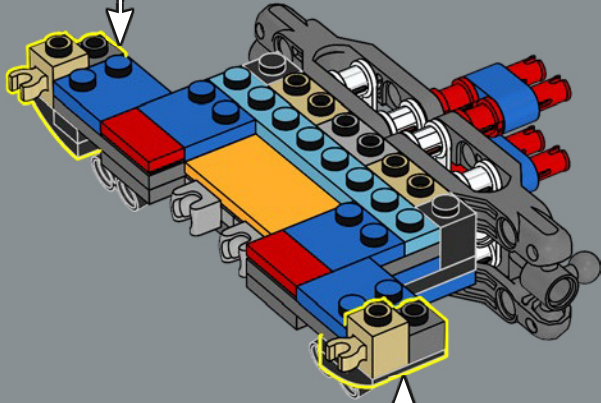
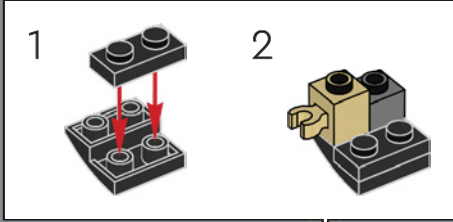

100

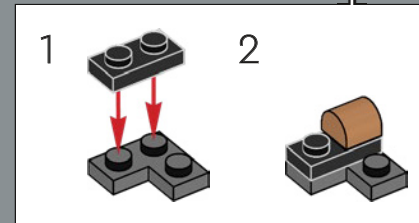
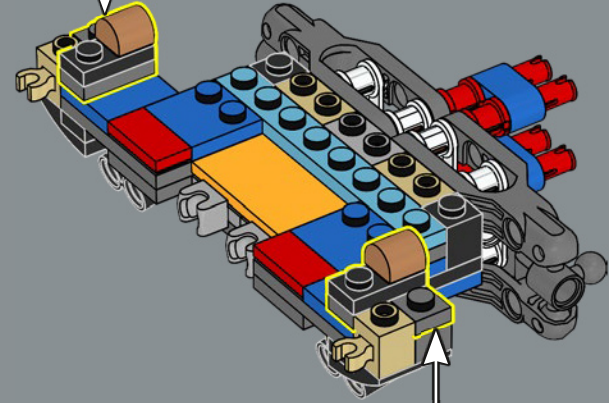
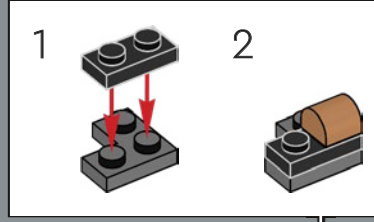



101

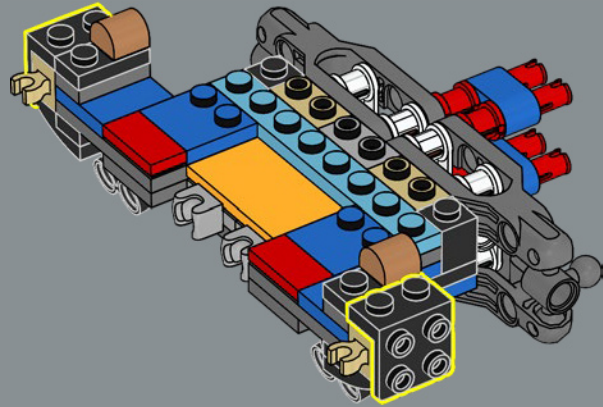

102

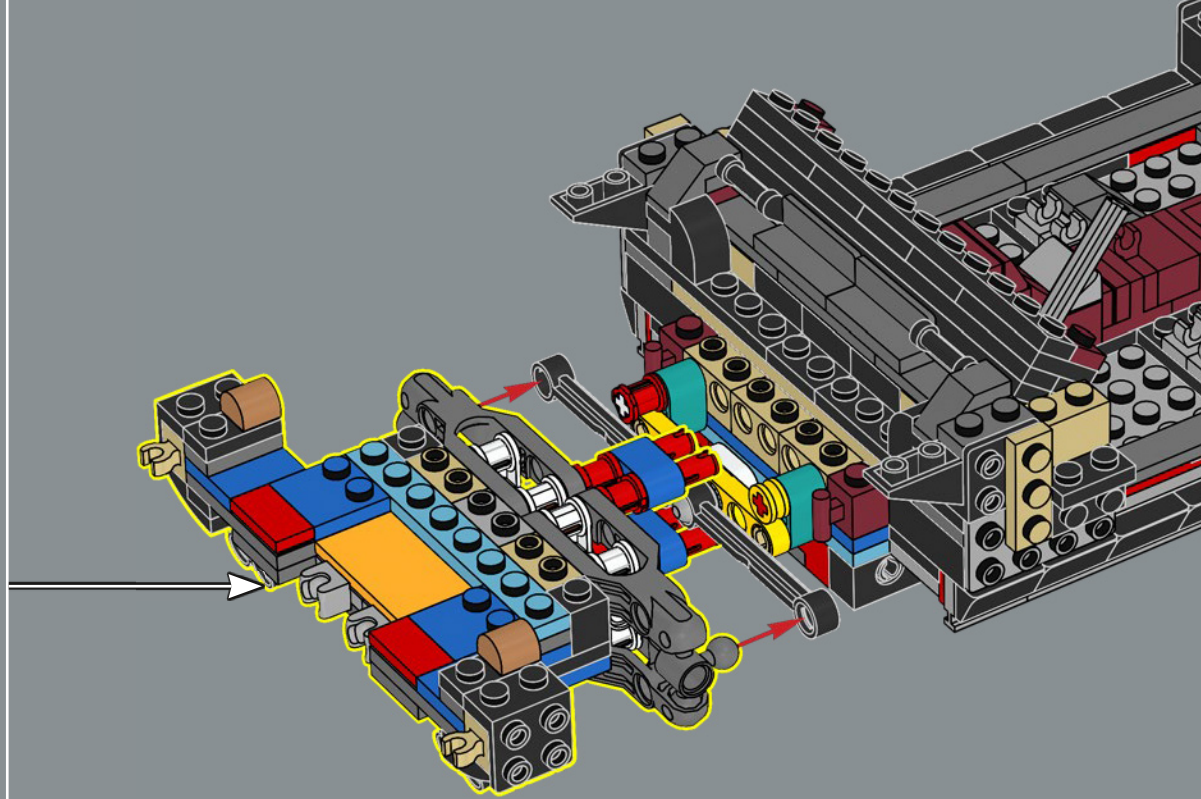

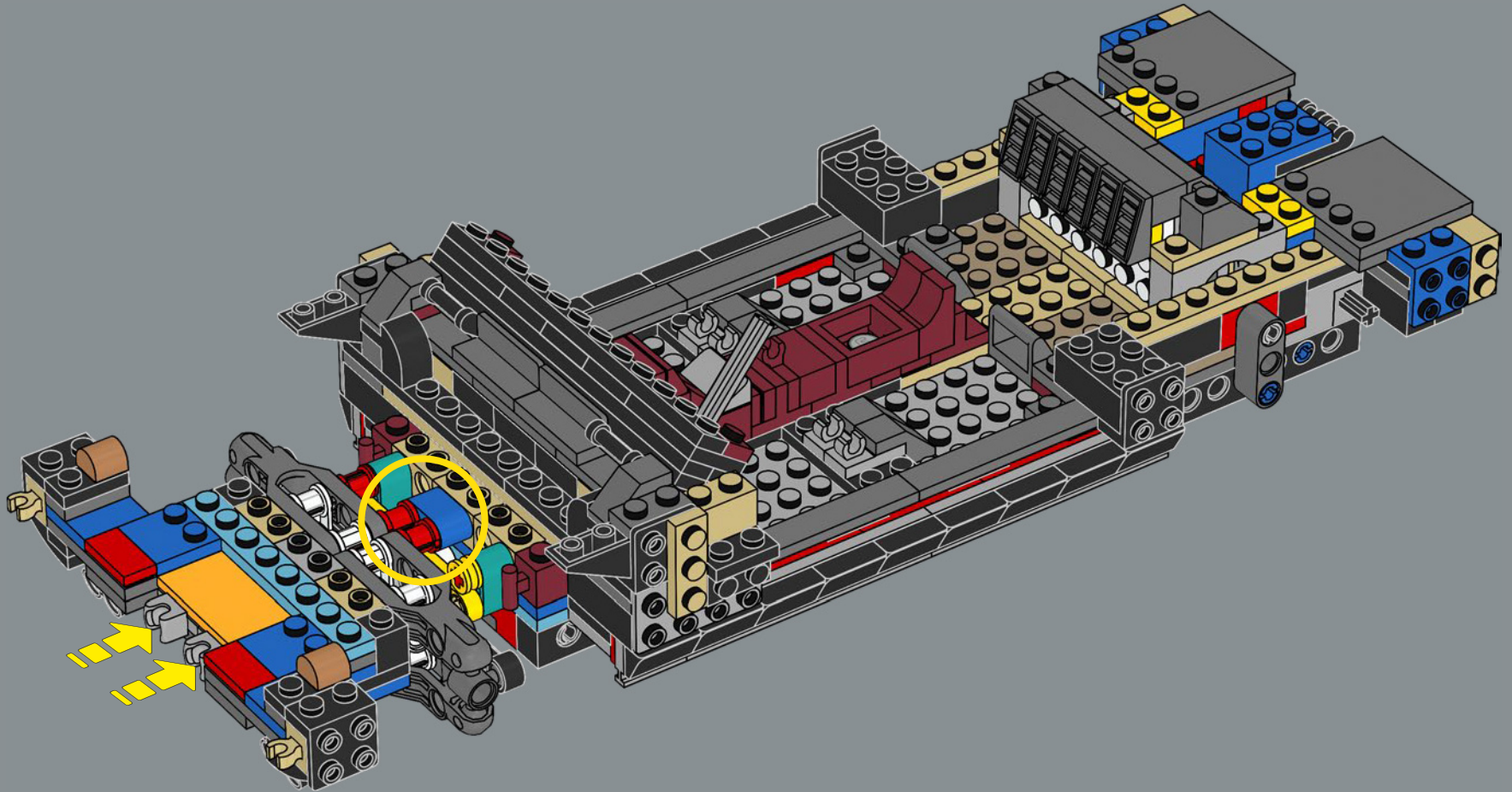

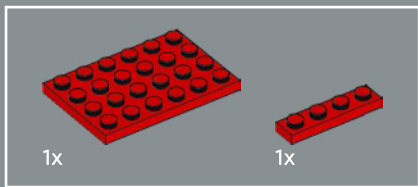

104

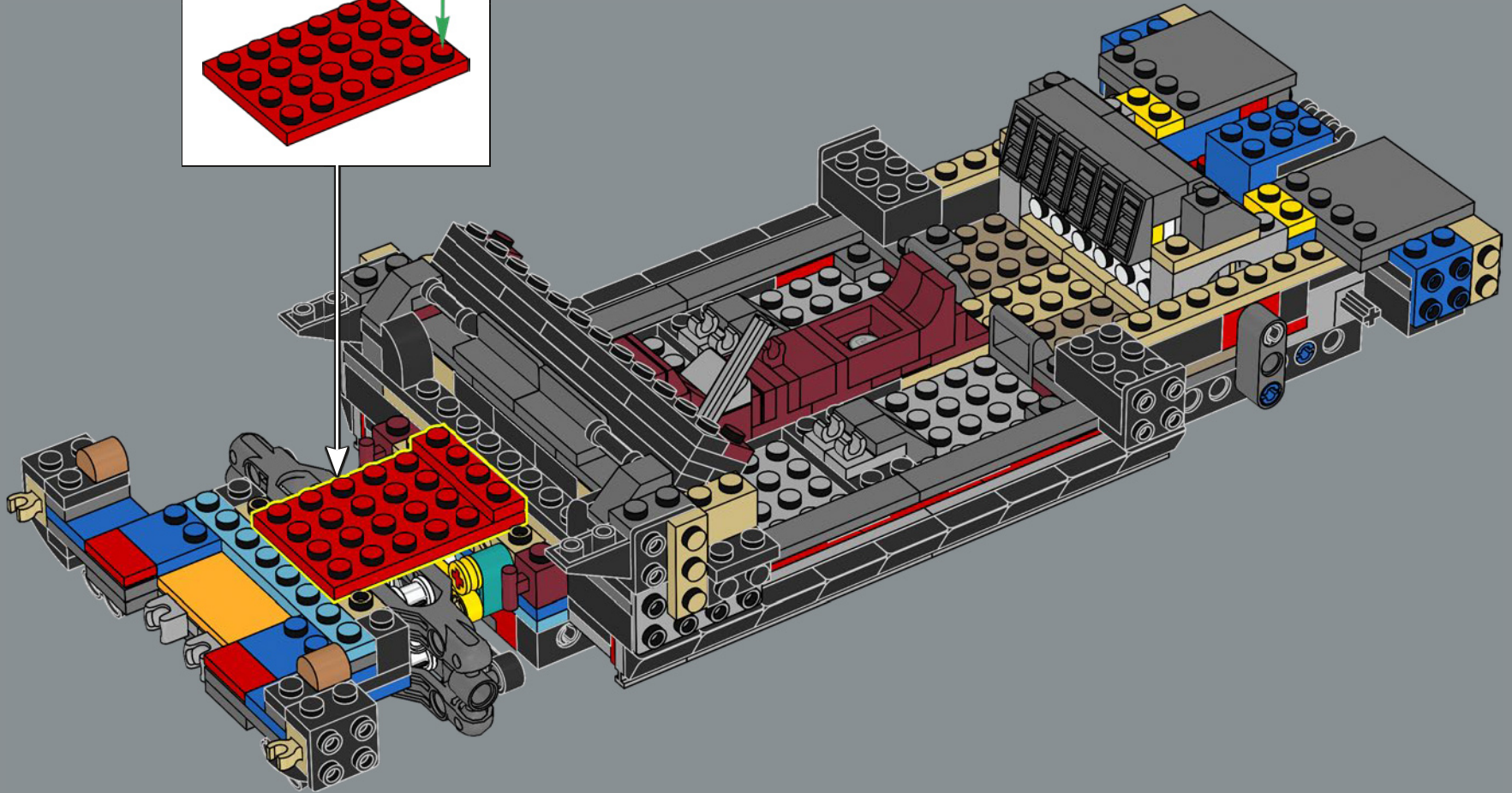
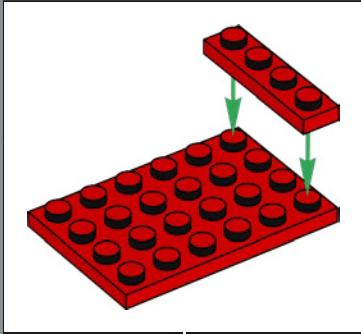



105

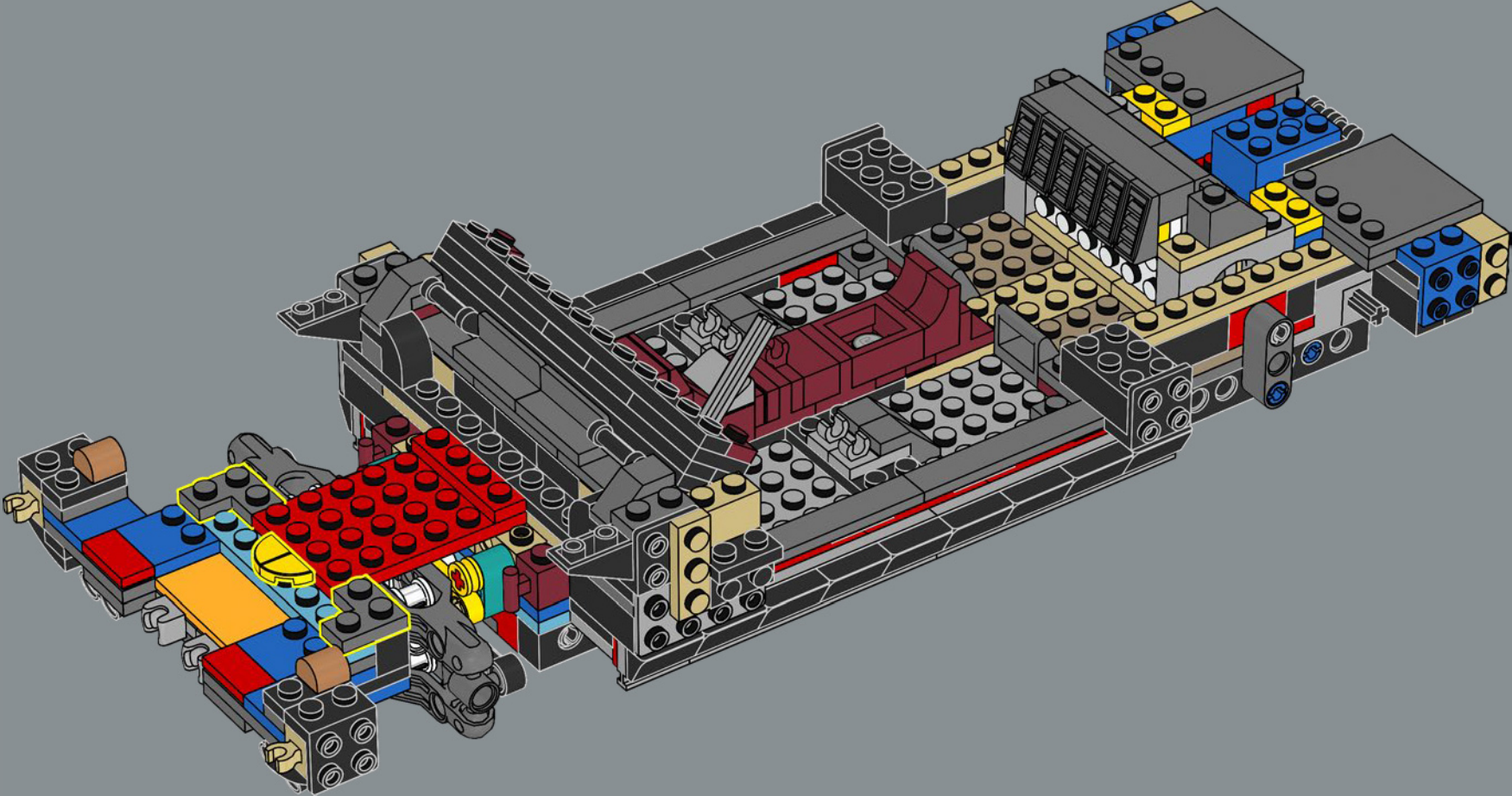

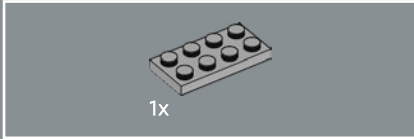
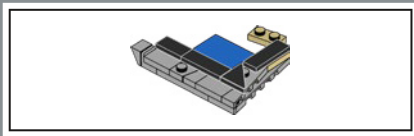

106

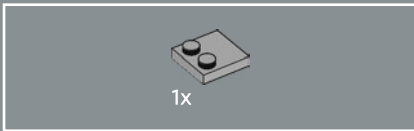

107

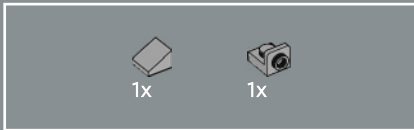
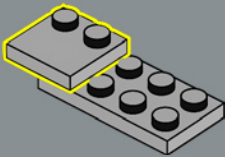

108

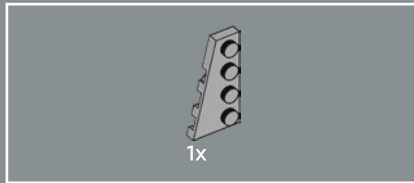
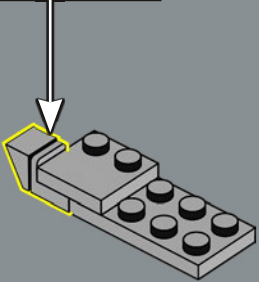
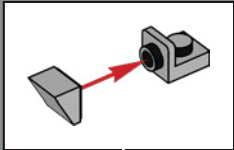

109

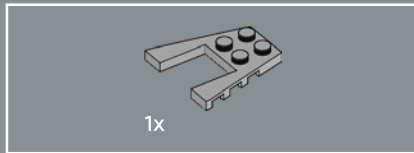
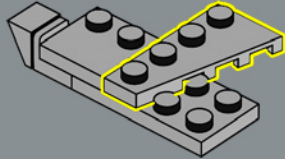

110

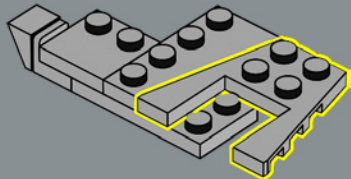

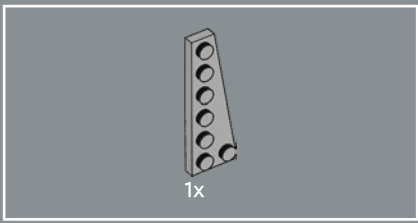

111

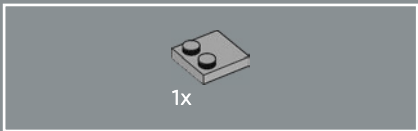
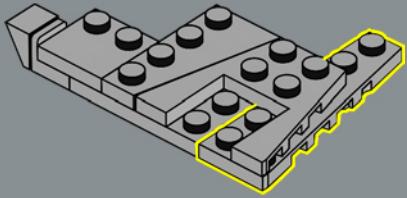

112

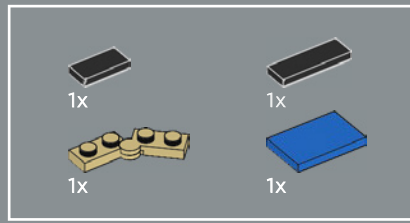
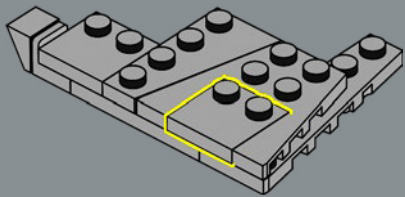

113

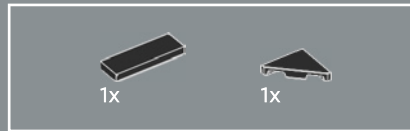
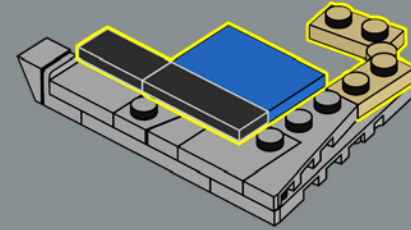

114

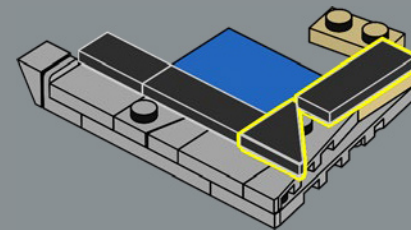

115

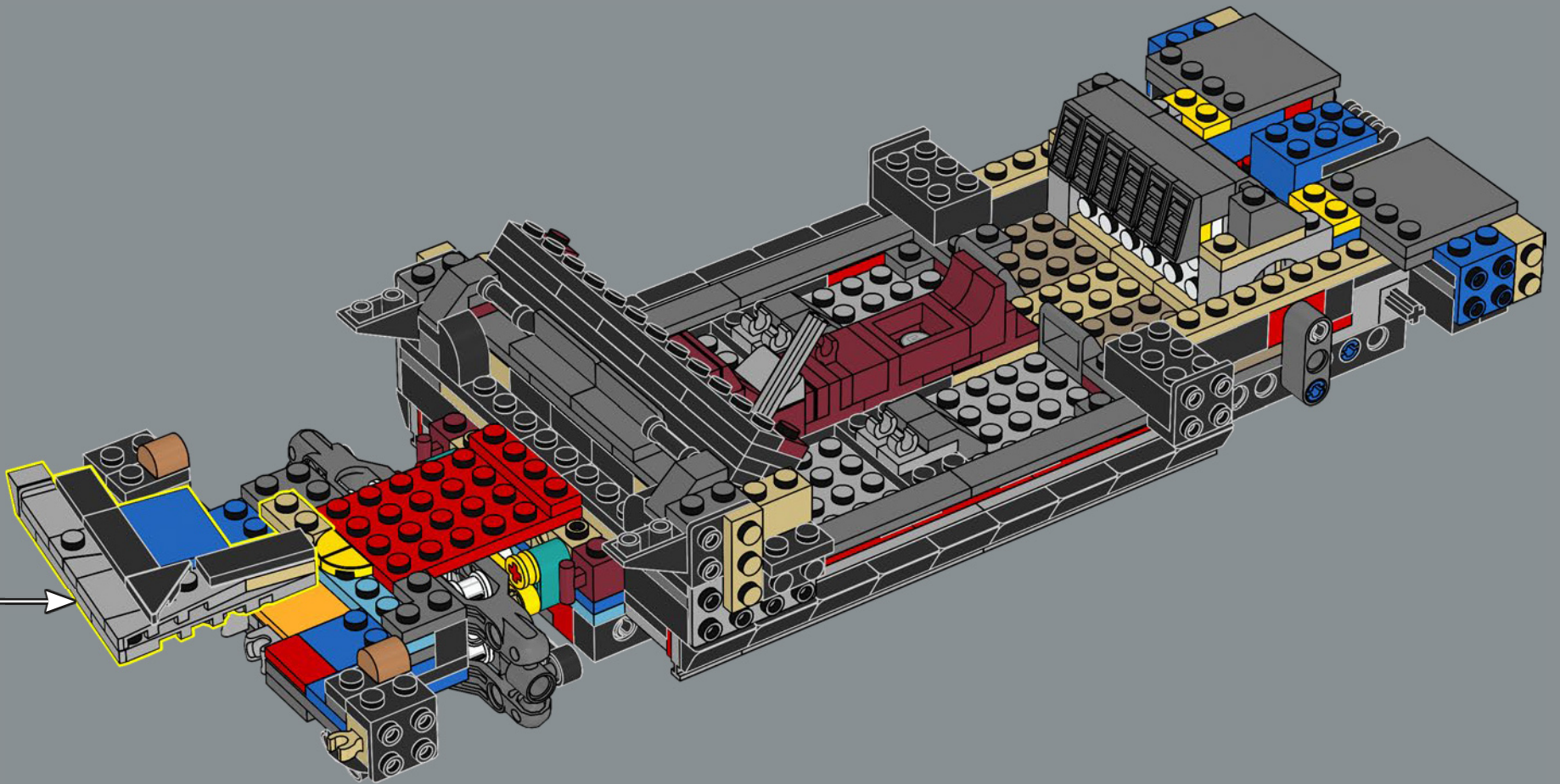

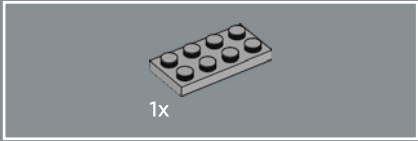
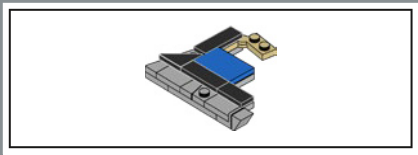

1x

116

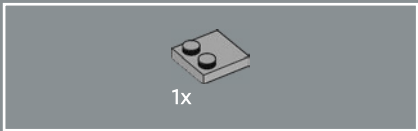
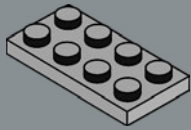

1x

117

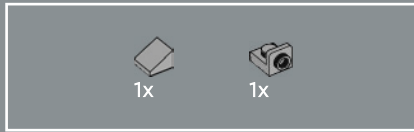
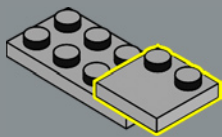

1x

1x

118

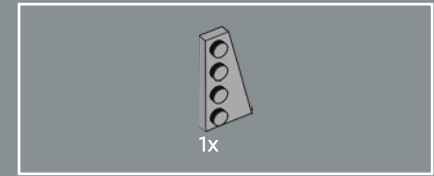
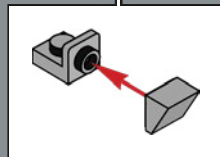
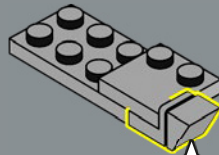

1x

119

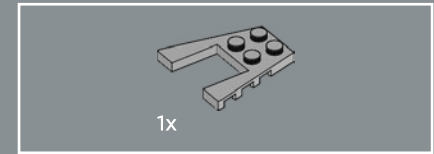
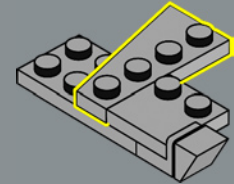

1x

120

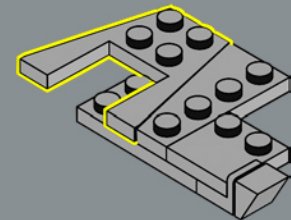

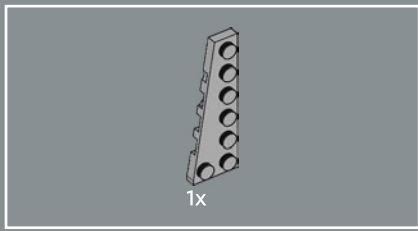

121

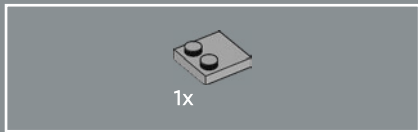
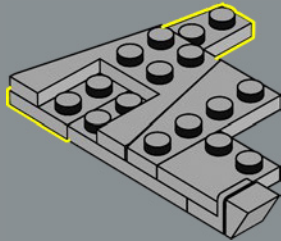

122

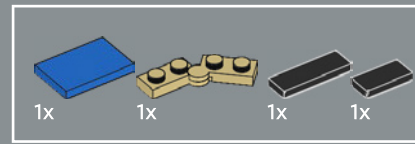
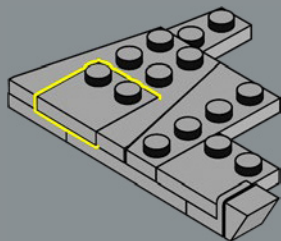

123

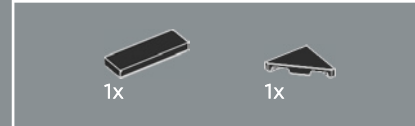
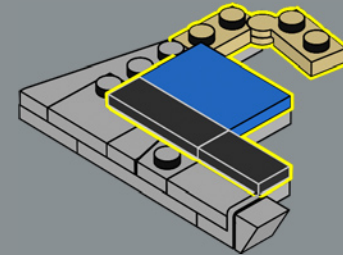

124

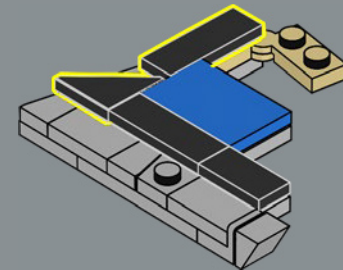

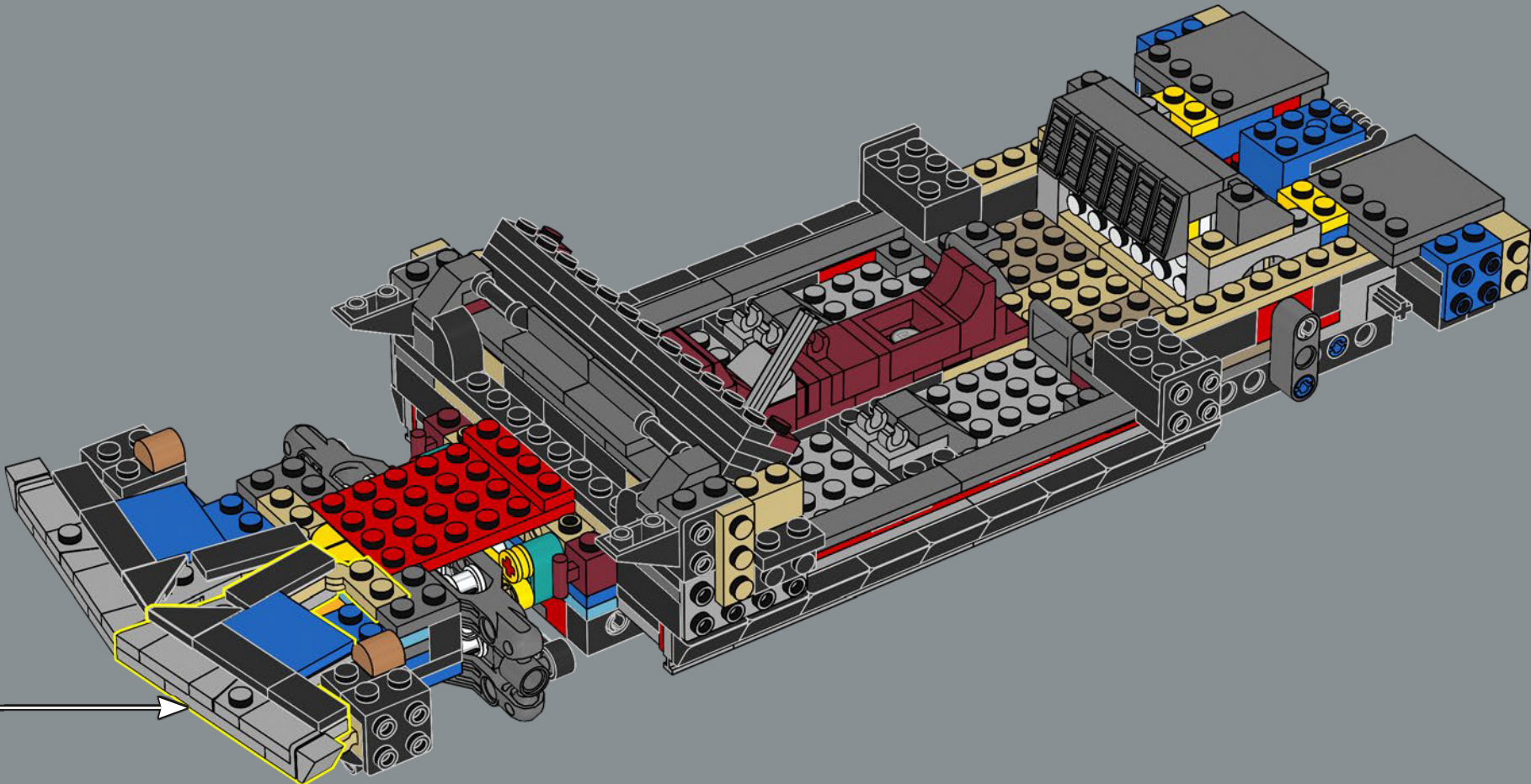

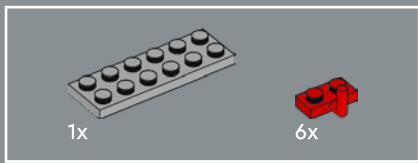

126

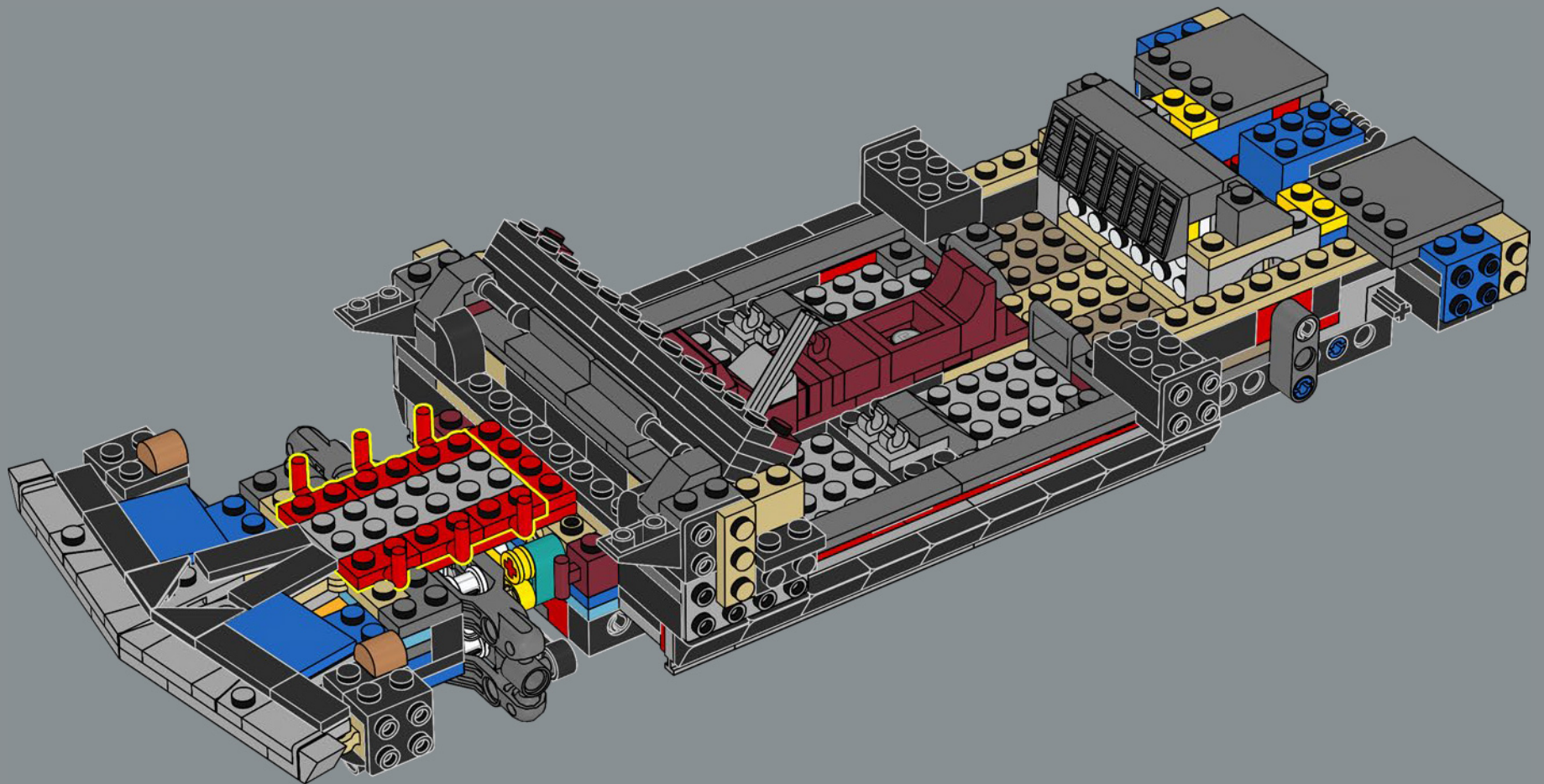

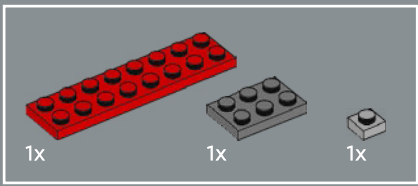

127

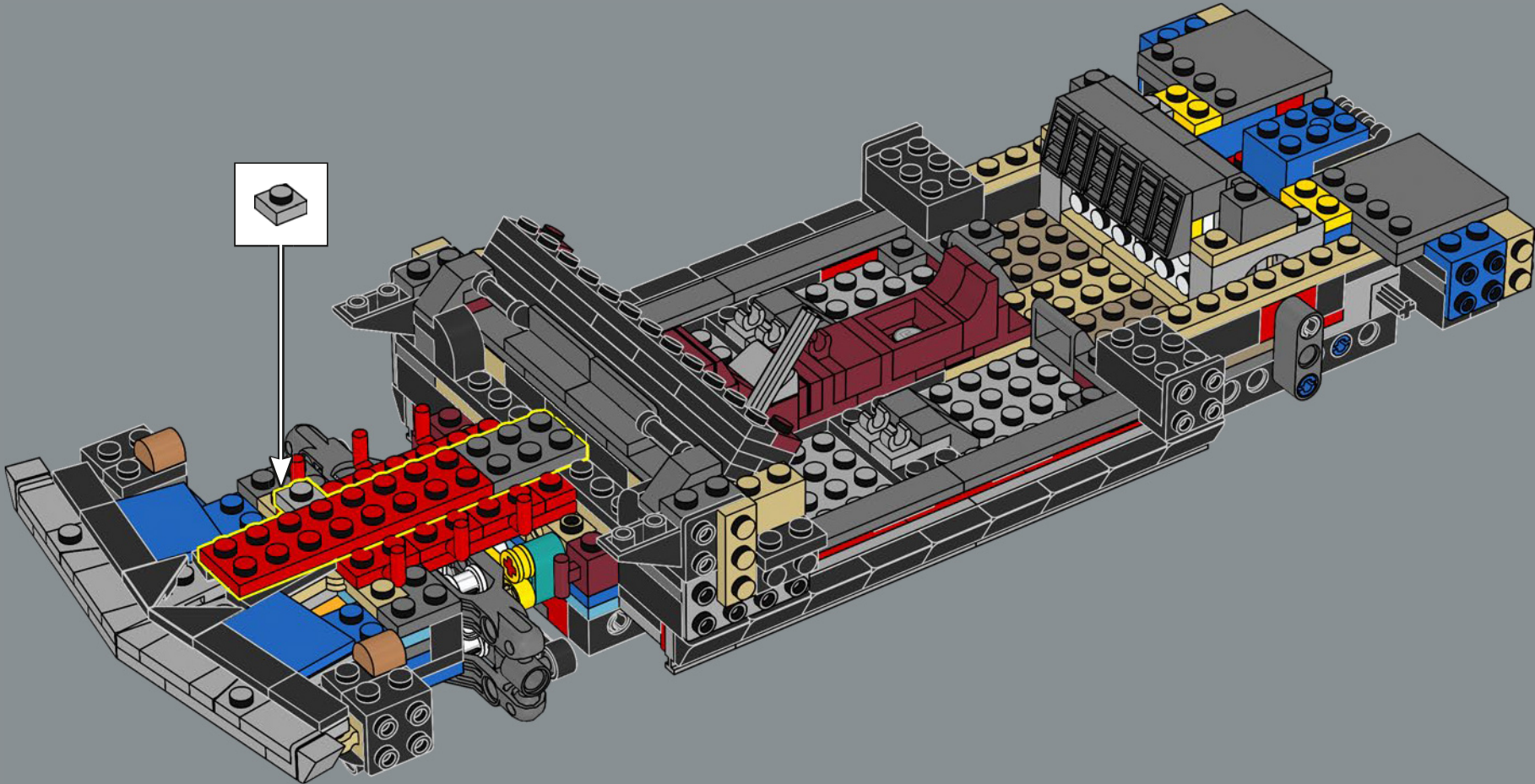

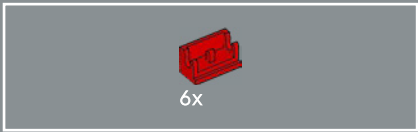

128

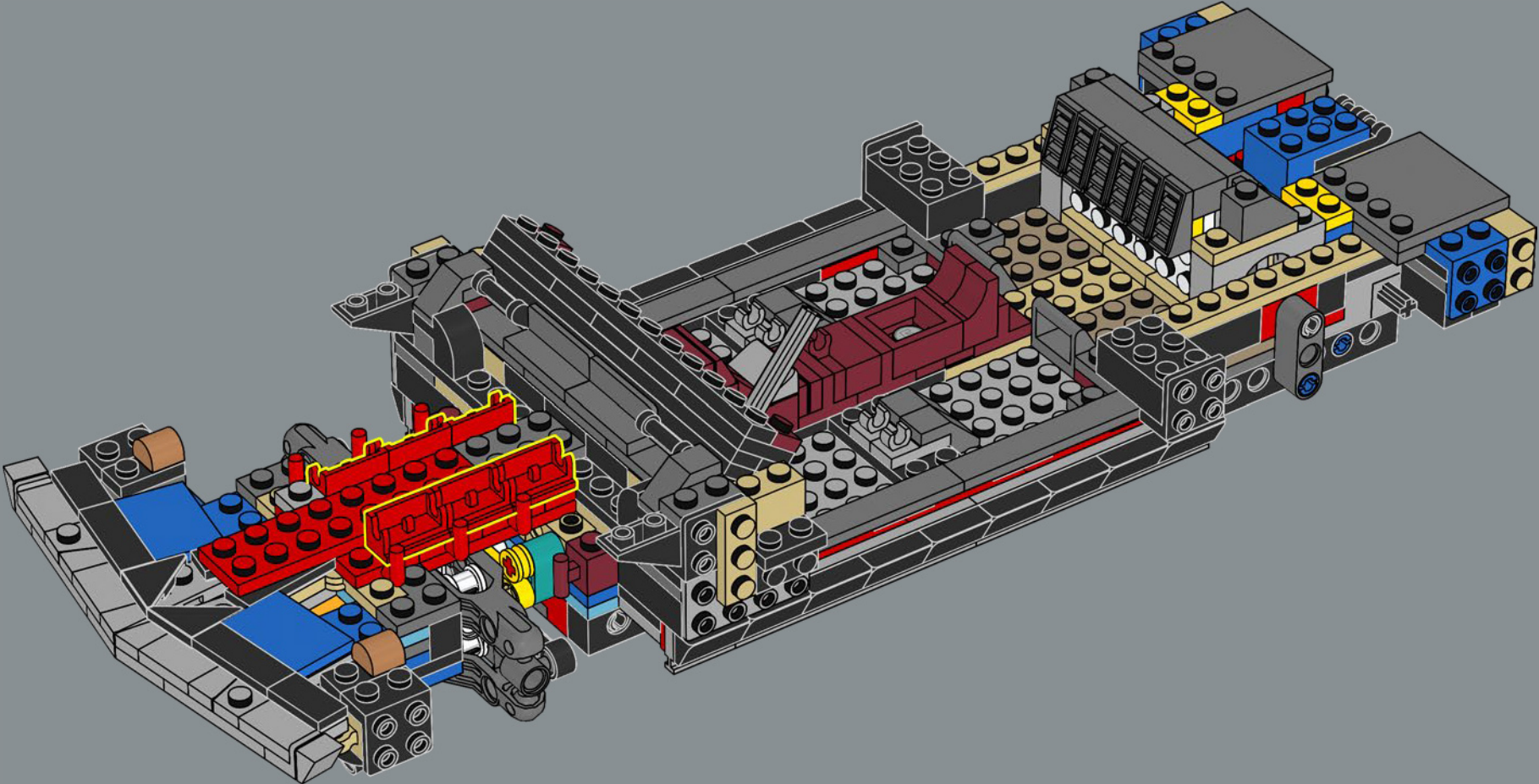

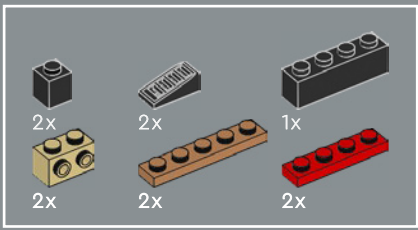

129

1

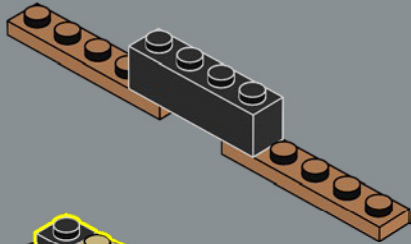

2

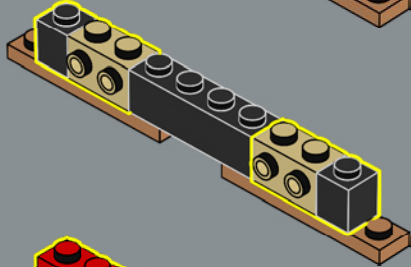

3

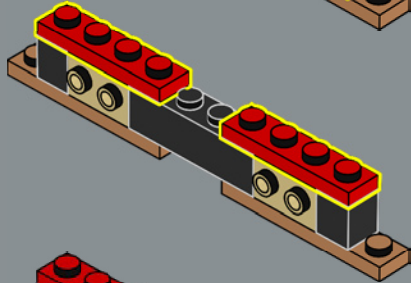

4

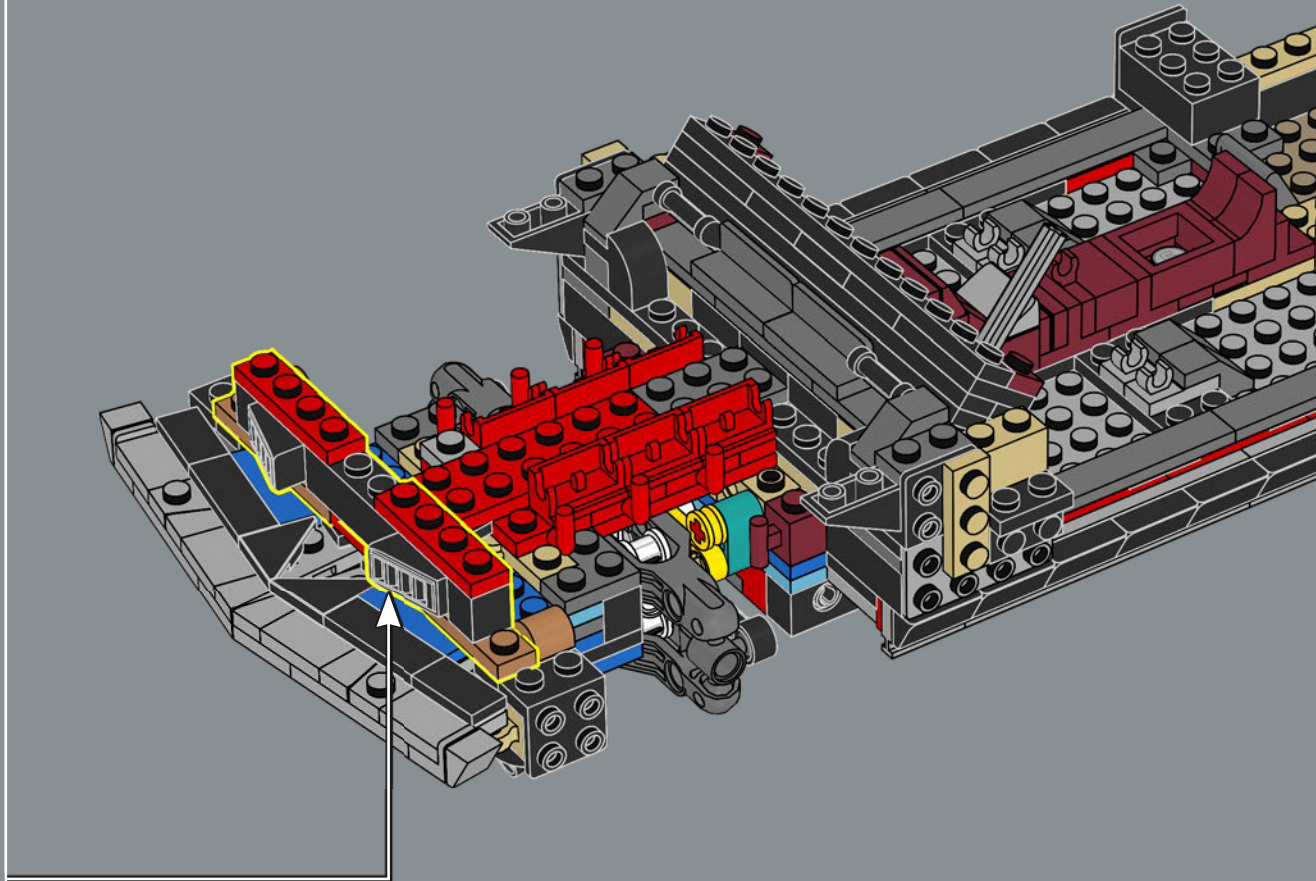
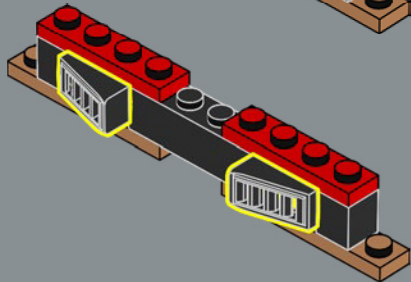

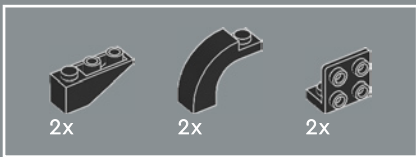

130

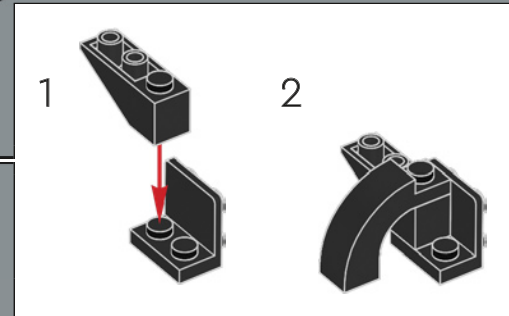
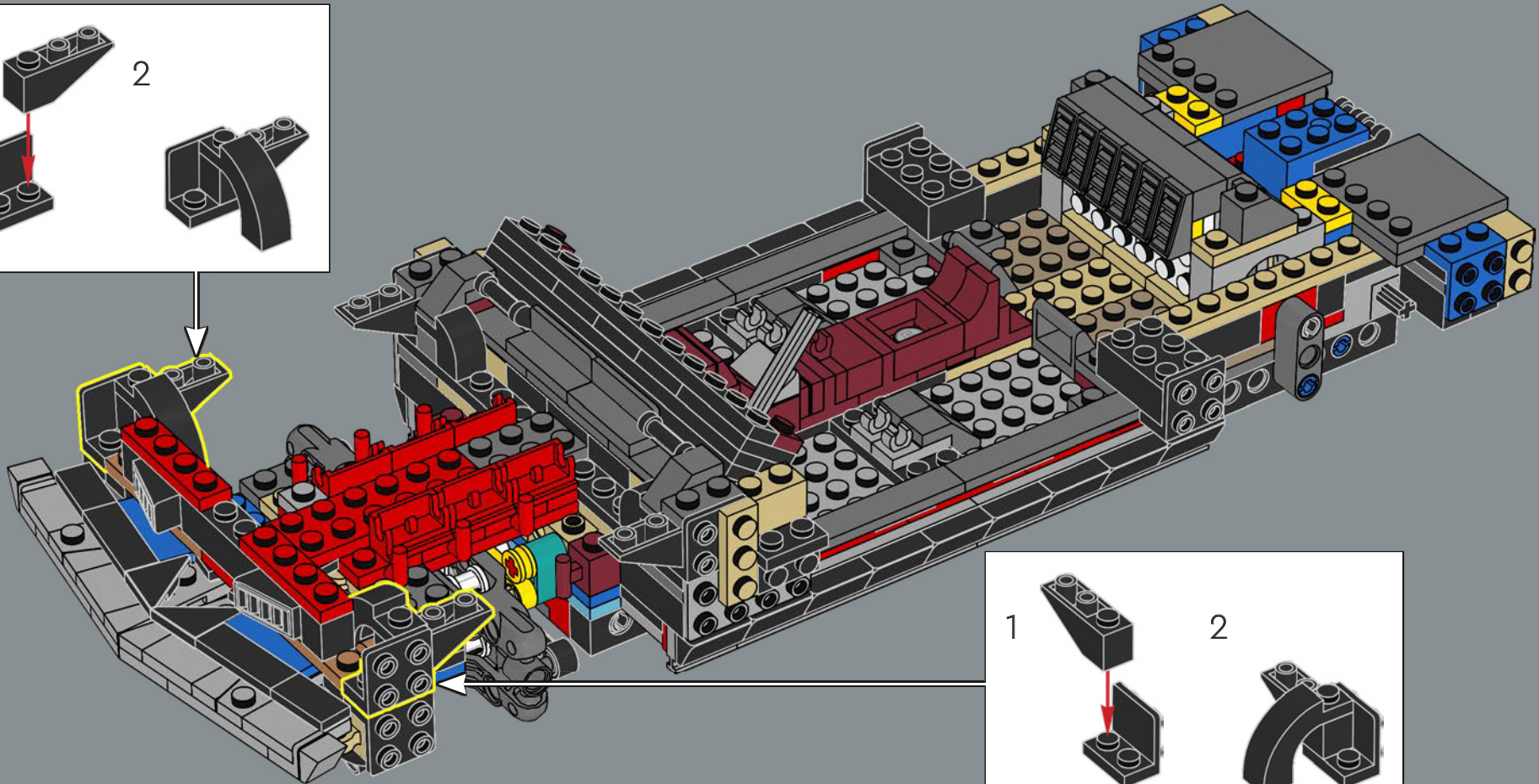
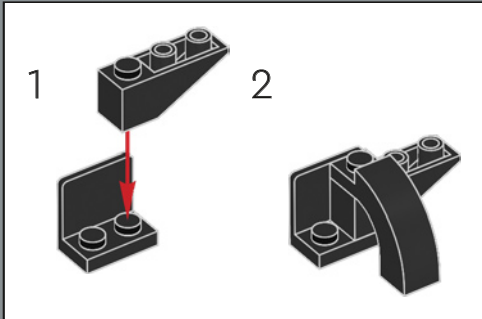

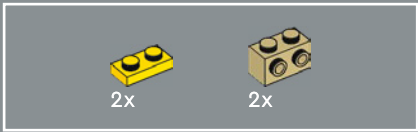

131

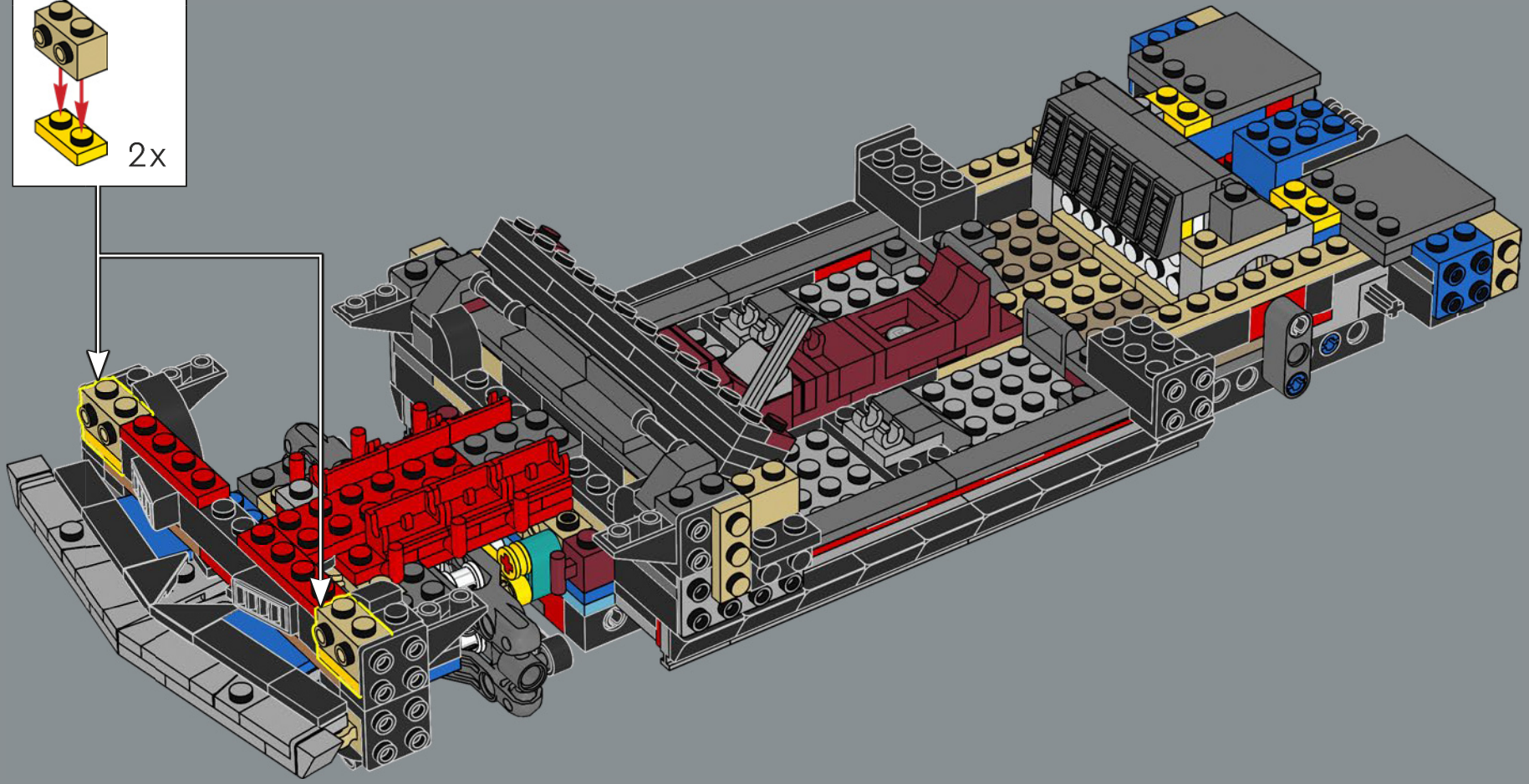
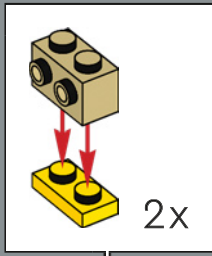

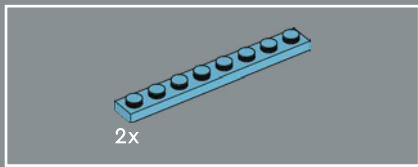

132

La presentación del Chevrolet Camaro ante la prensa en 1966 fue la primera retransmisión a gran escala del mundo. Más de 200 periodistas de 14 ciudades estadounidenses participaron en ella.

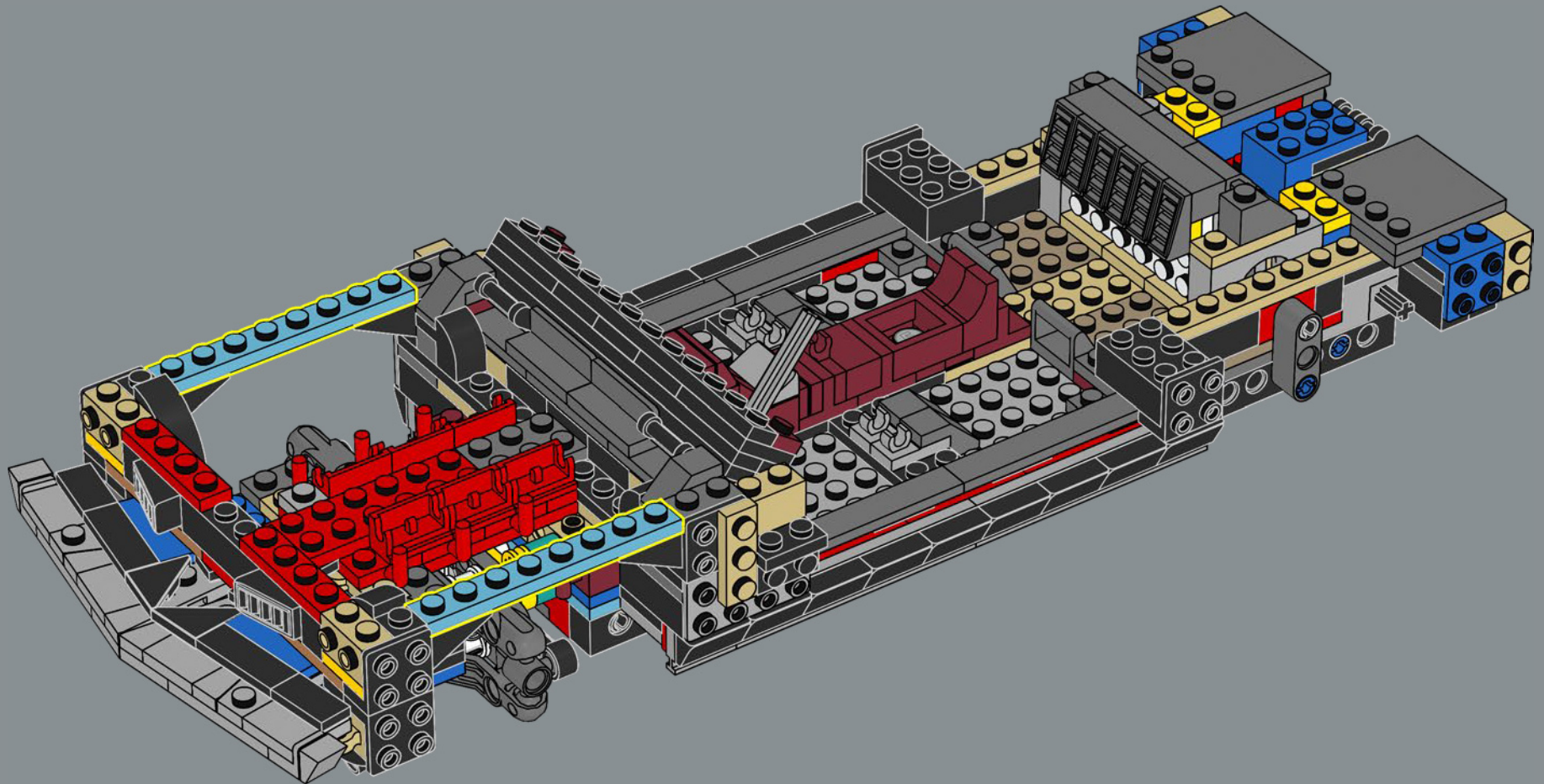



133

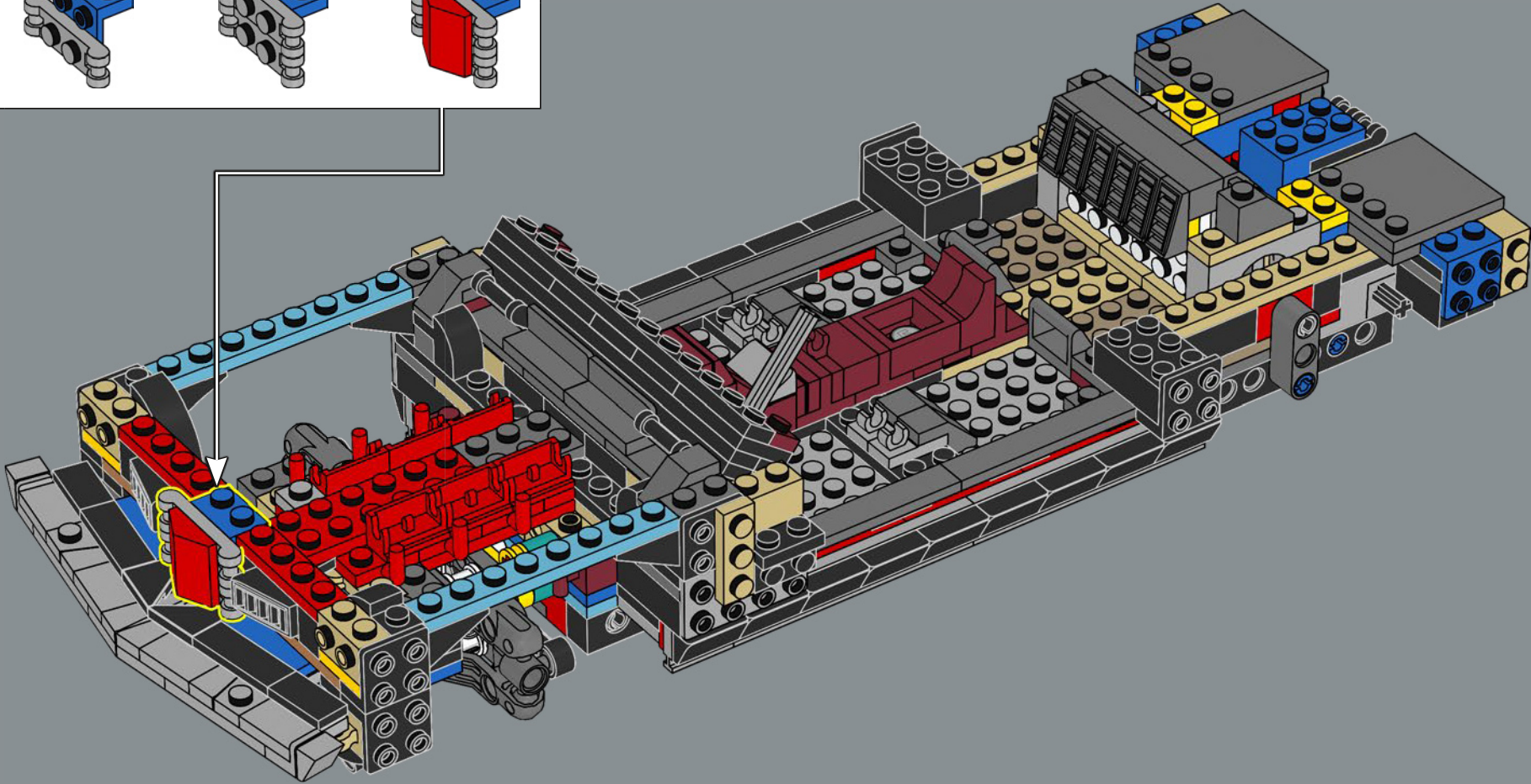
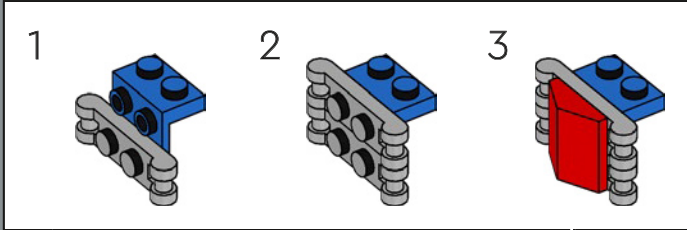



134

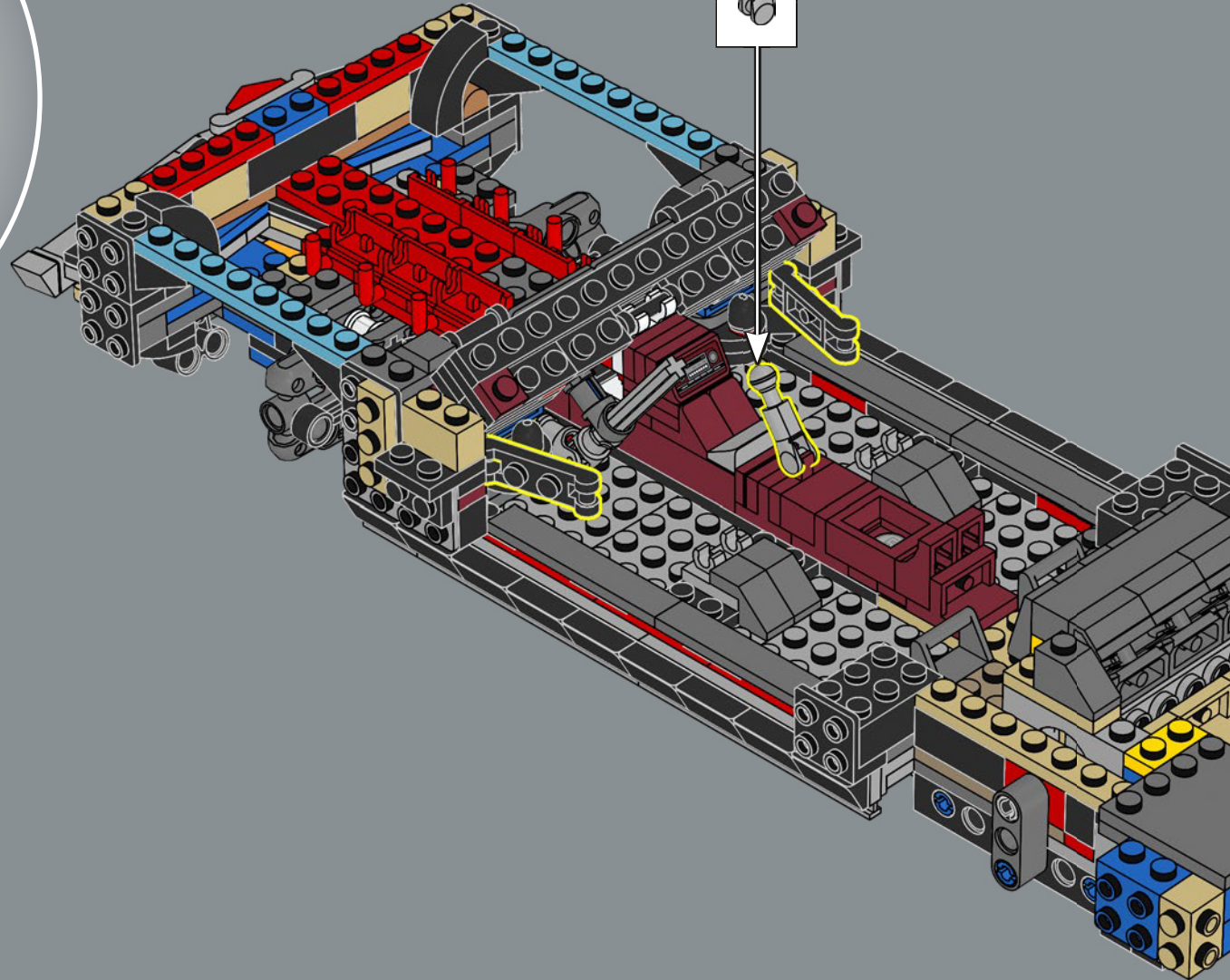
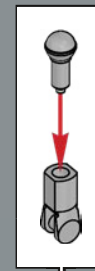

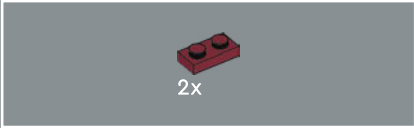
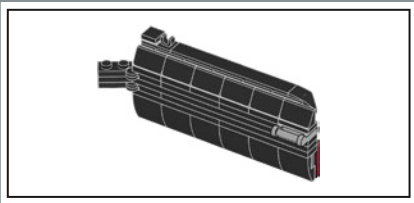

2x

135

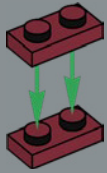

1x

136

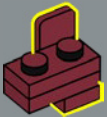

1x

137

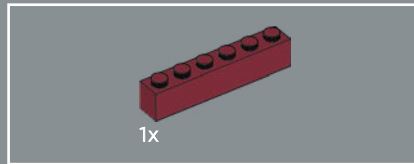
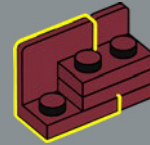

1x

138

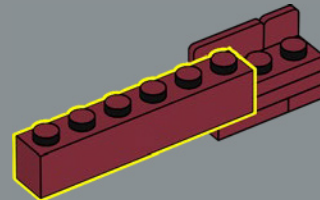

2x

1x

139

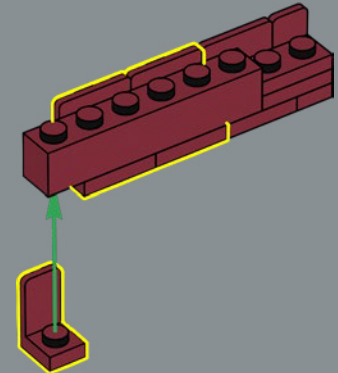



140

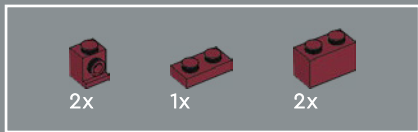
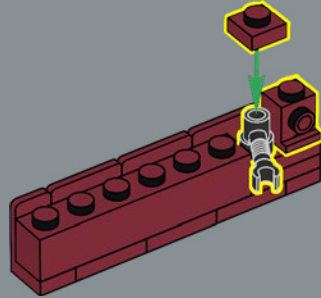

141

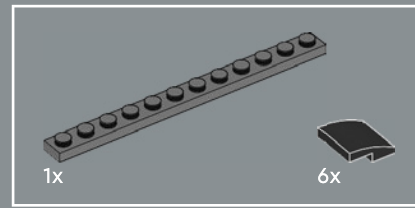
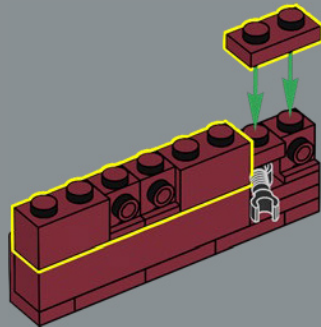

142

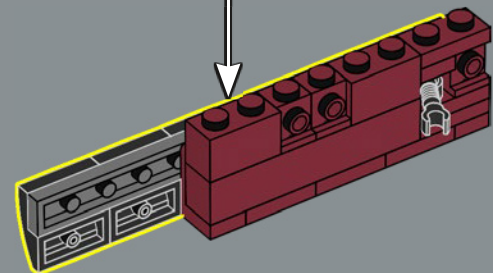
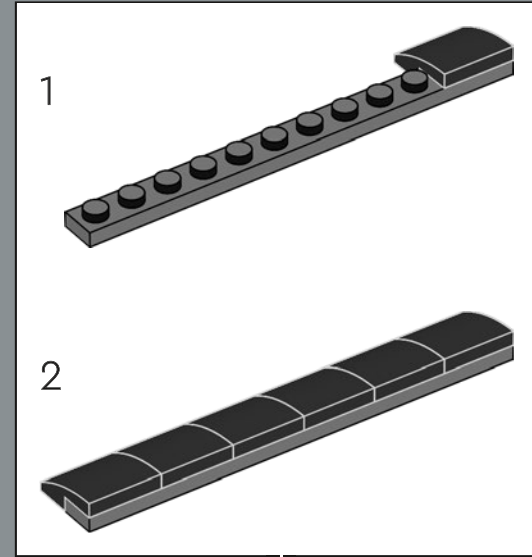

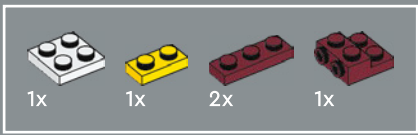

143

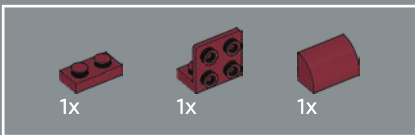
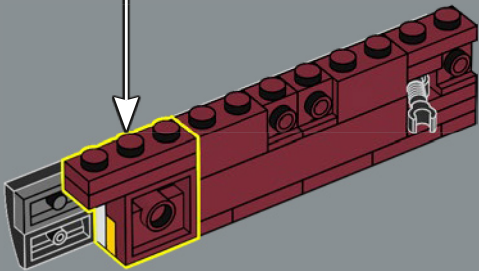
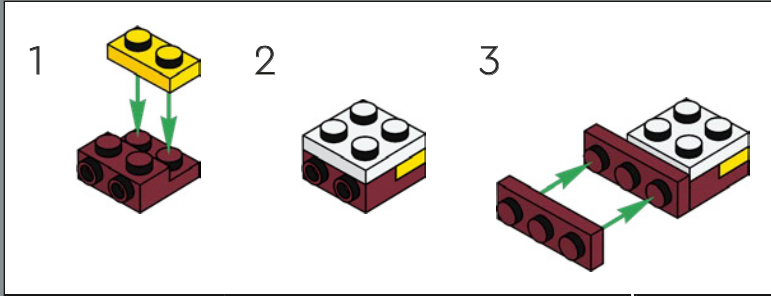

144

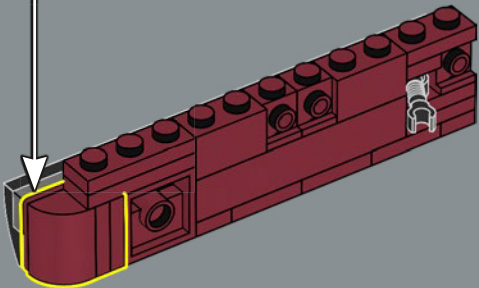
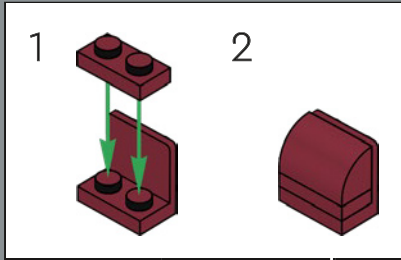

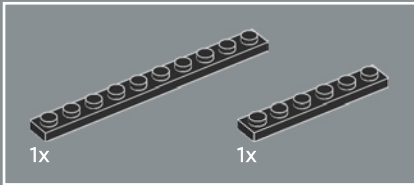
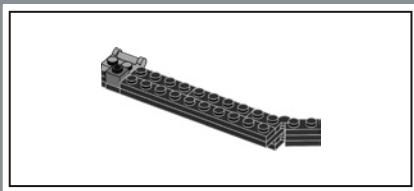

145

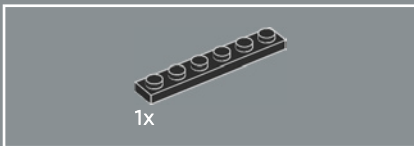
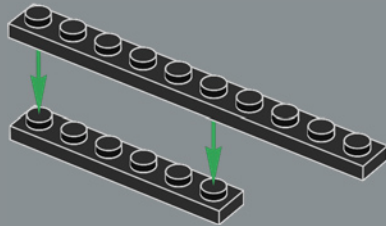

146

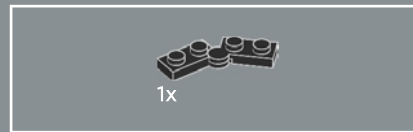
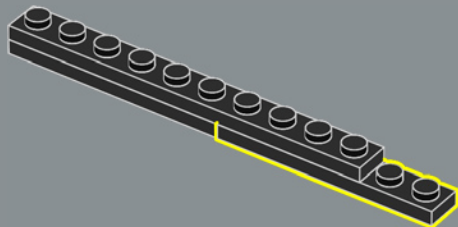

147

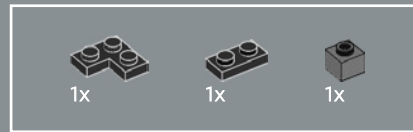
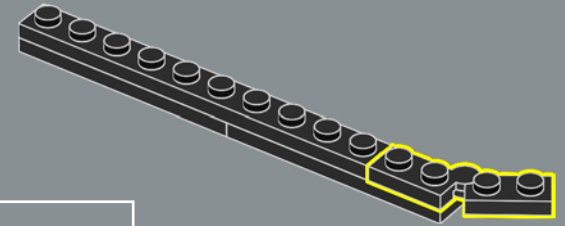

148

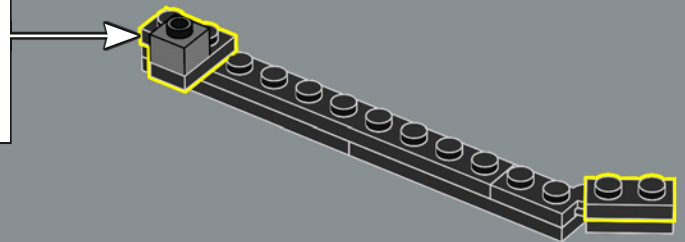
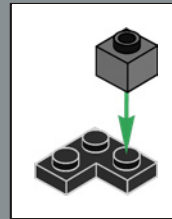

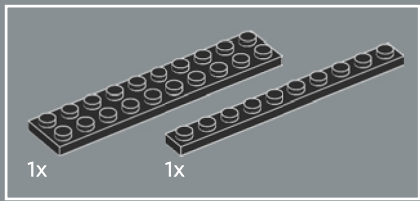

149

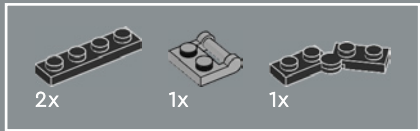
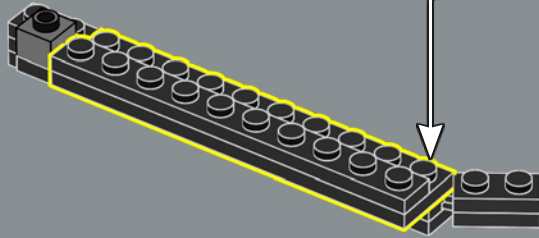
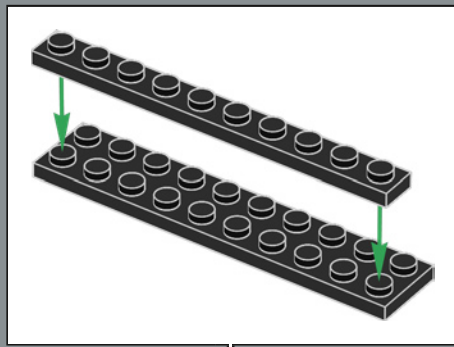

150

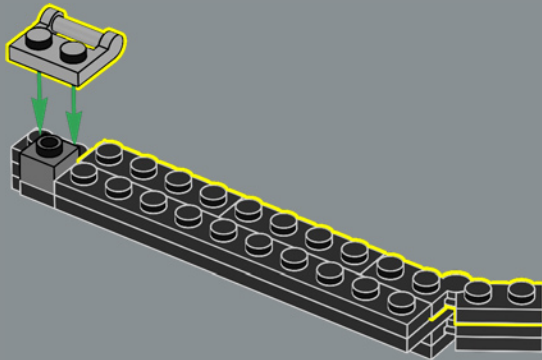

151

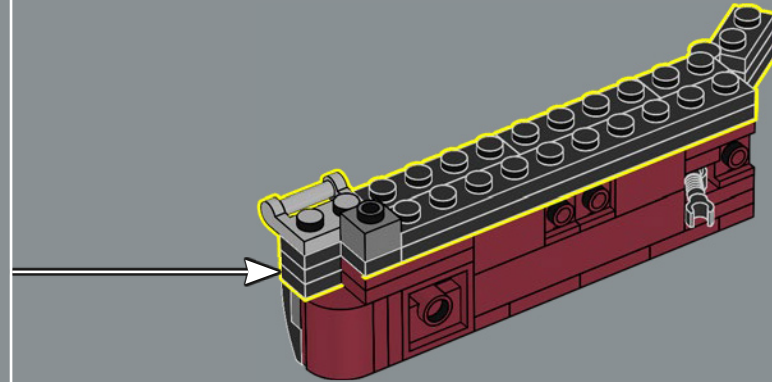



152

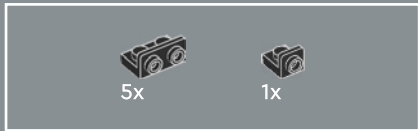
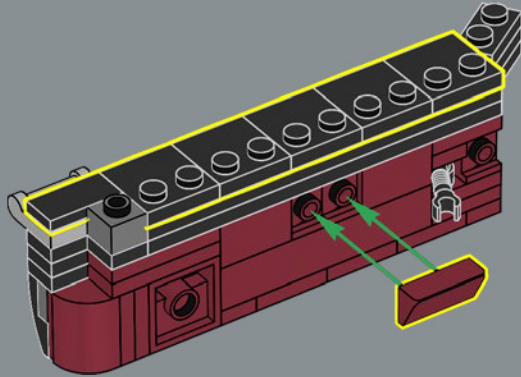

153

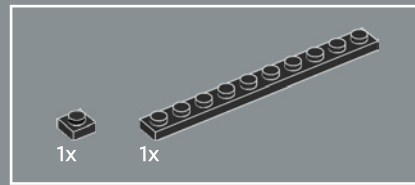
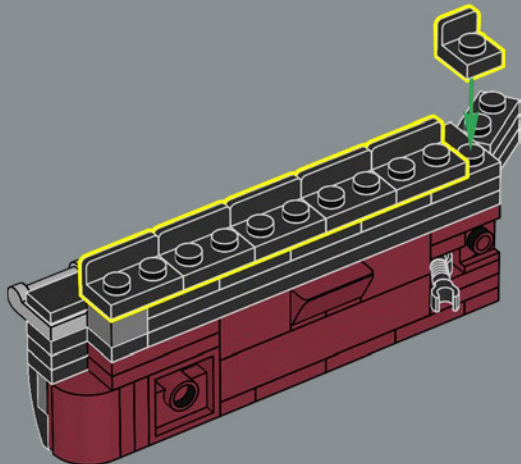

154

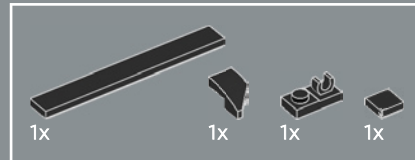
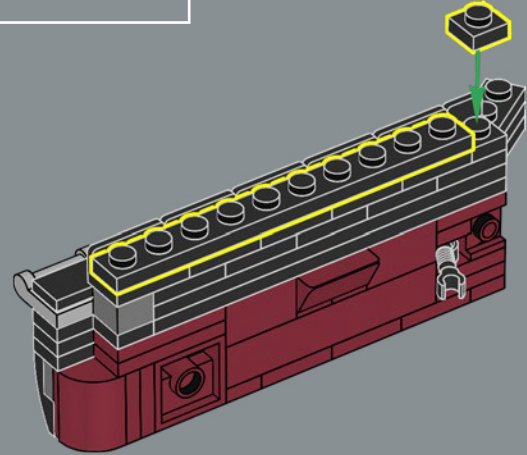

155

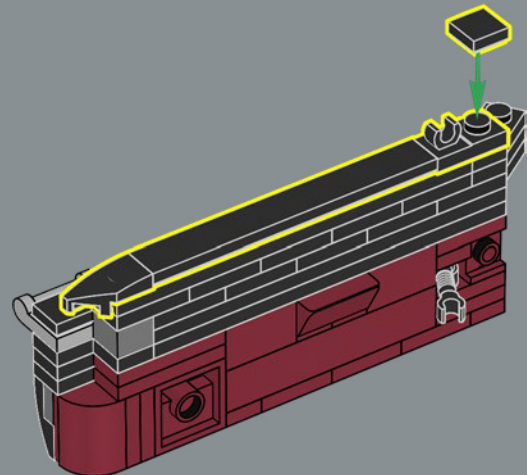



6x

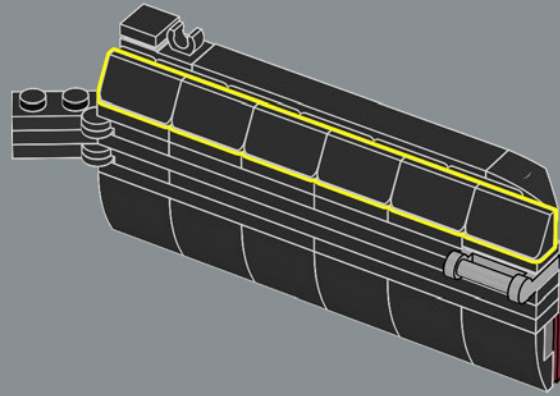

156

157

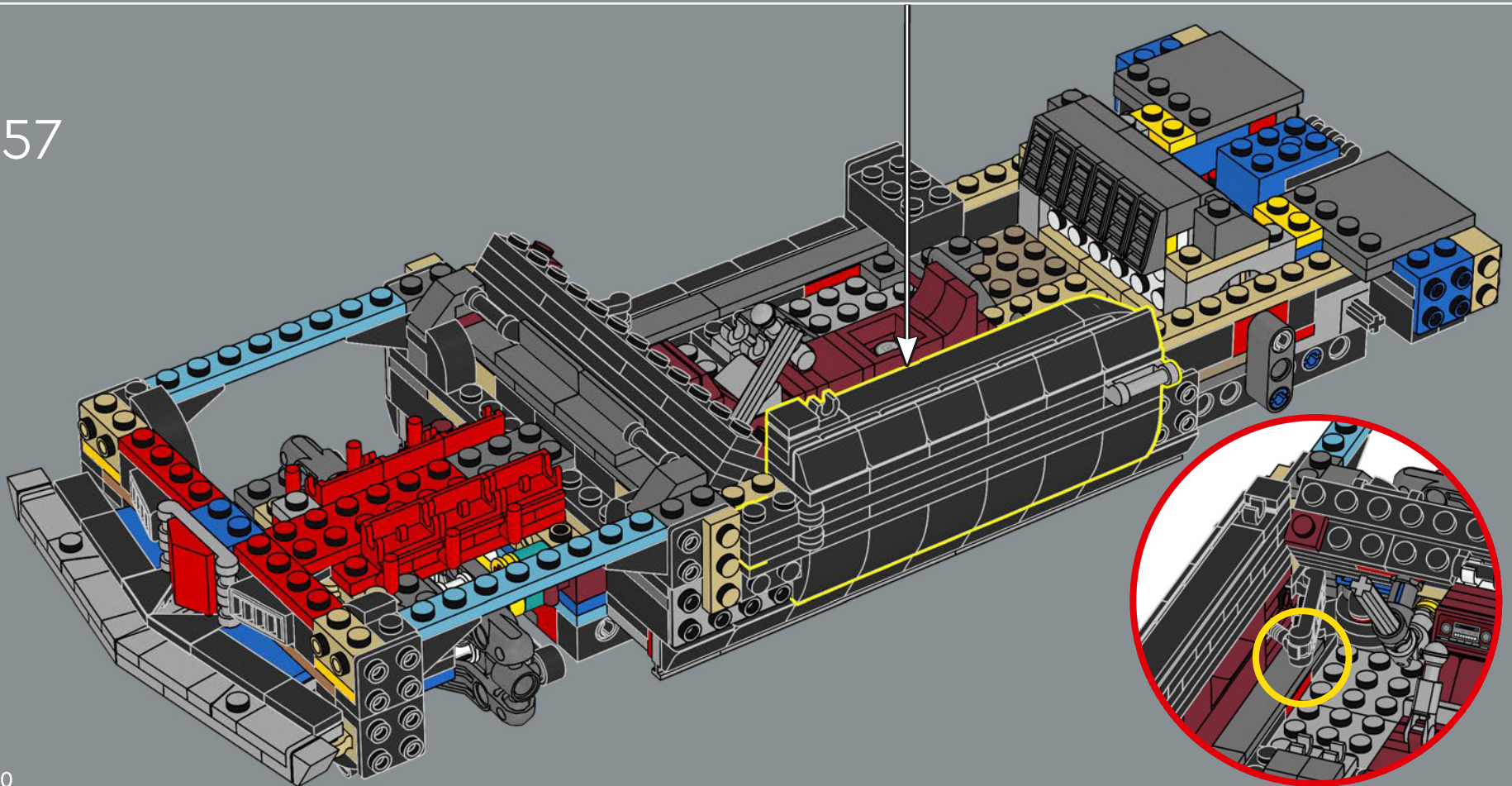



158

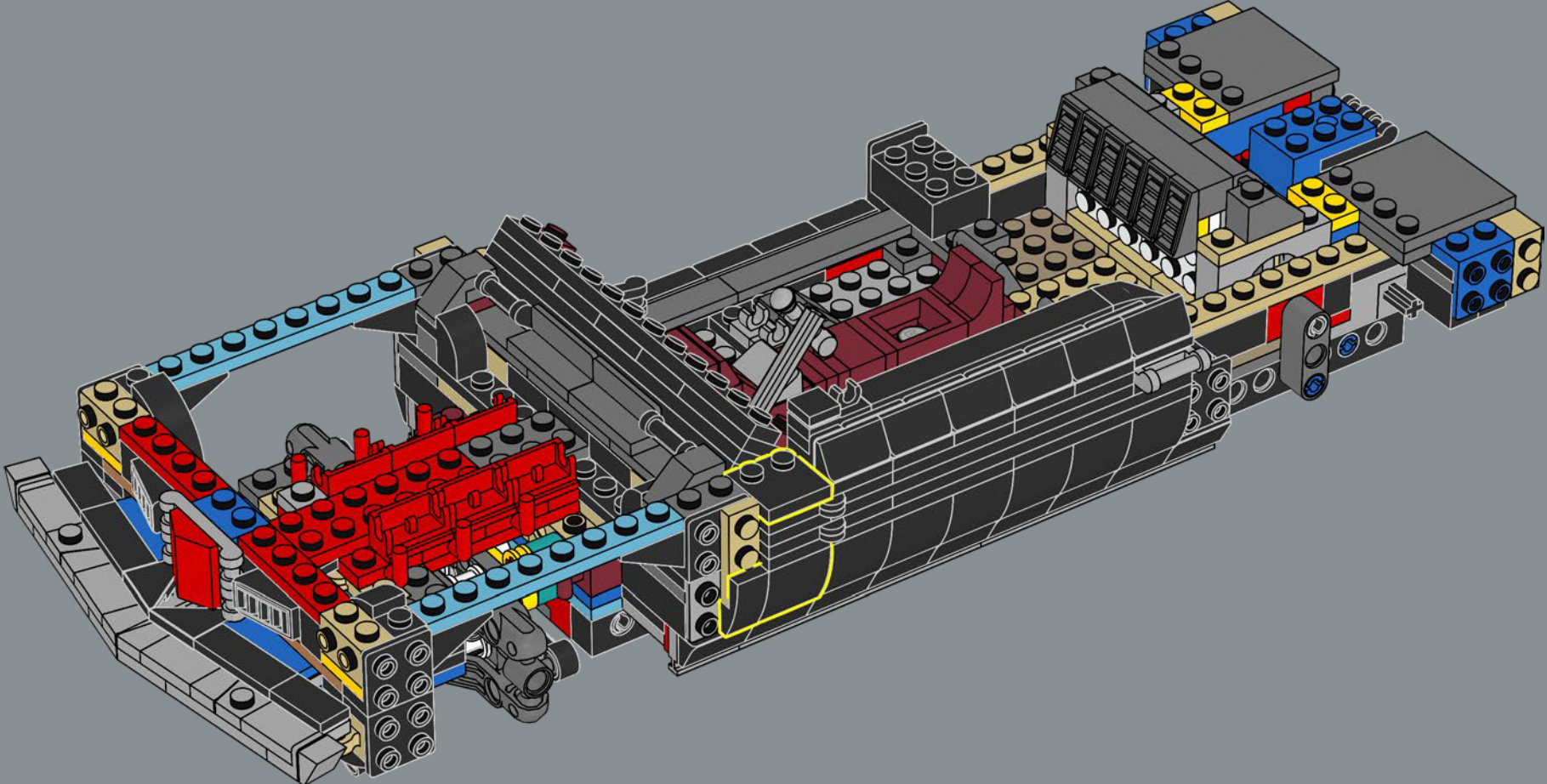

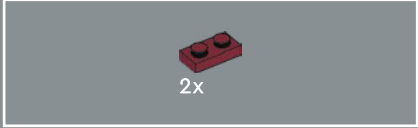
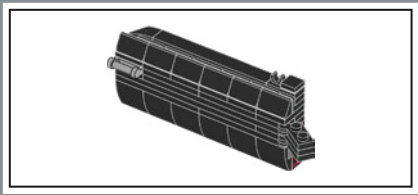

159

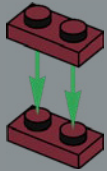

160



161

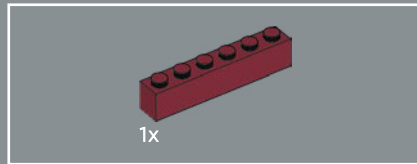
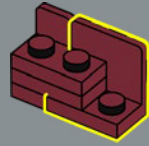

162

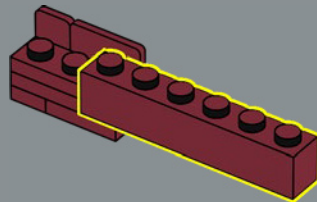

163

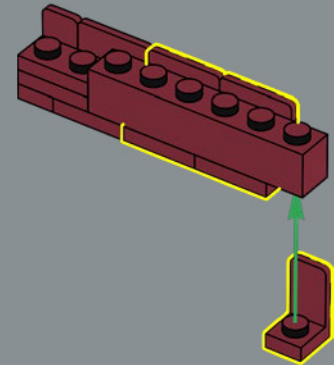



164

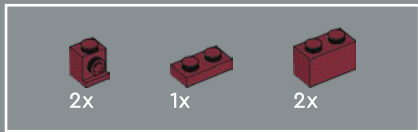
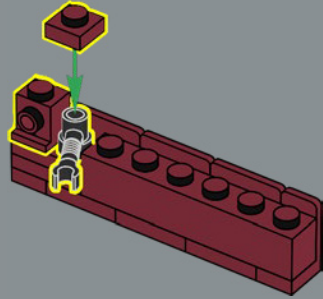

165

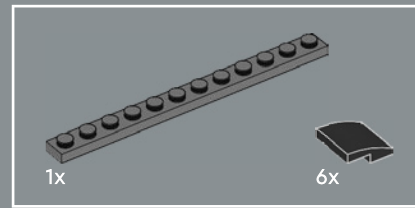
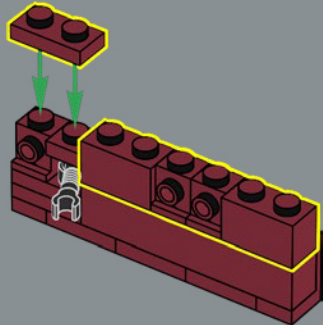

166

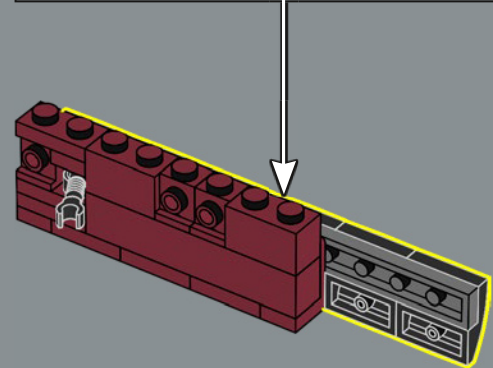
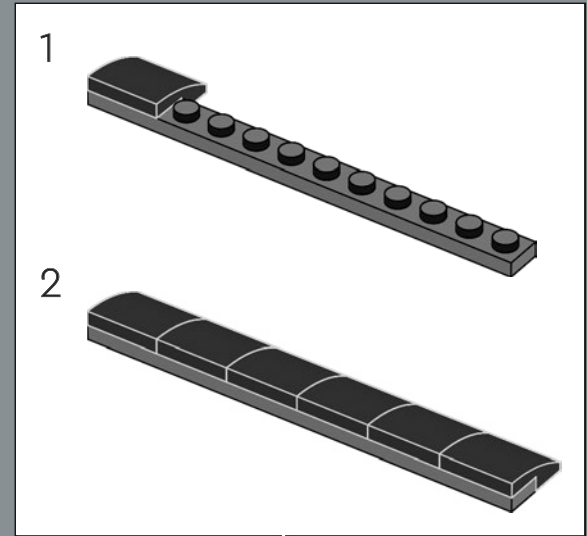

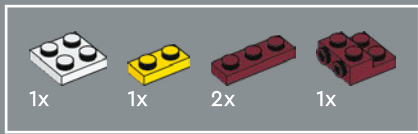

167

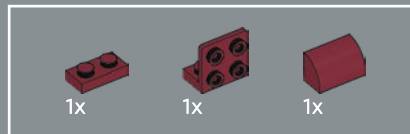
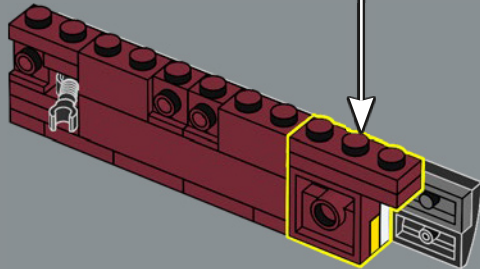
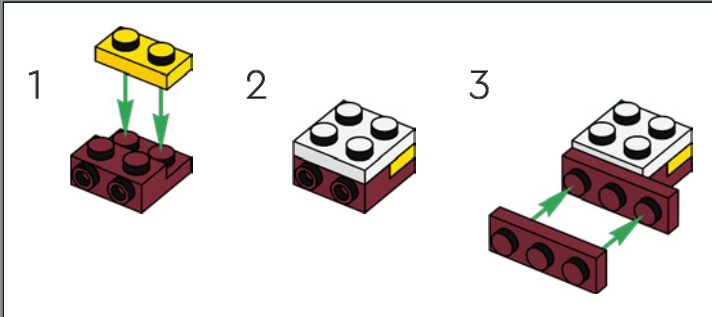

168

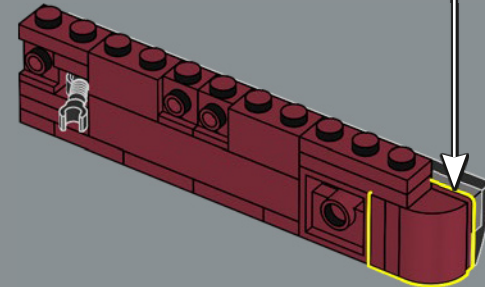
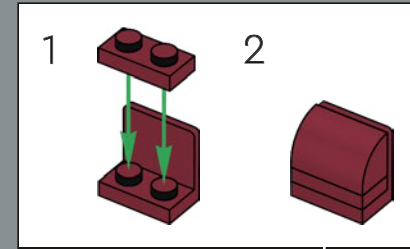

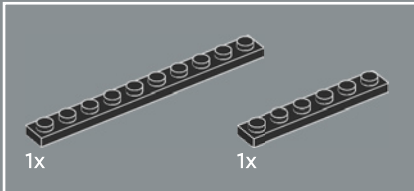
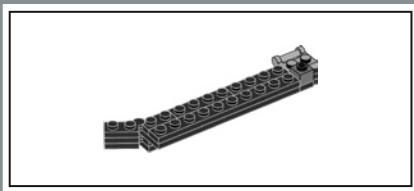

169

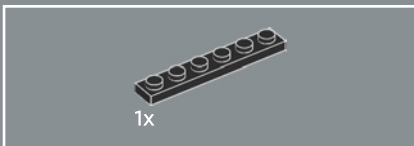
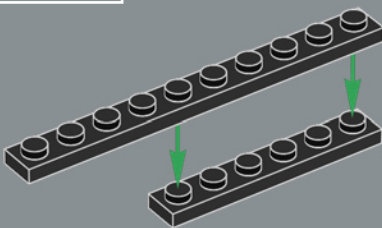

170

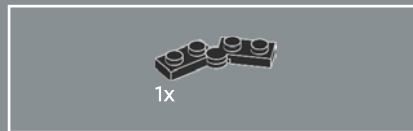
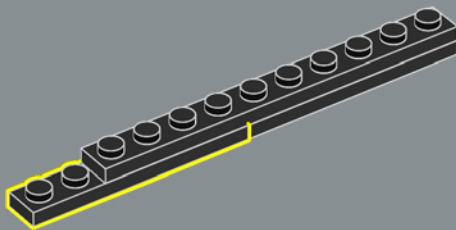

171

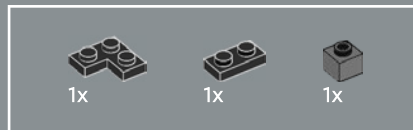
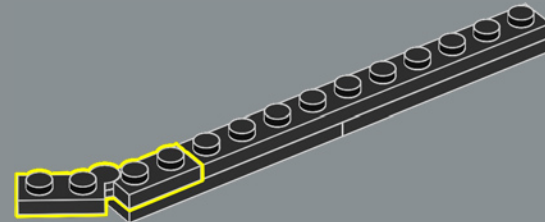

172

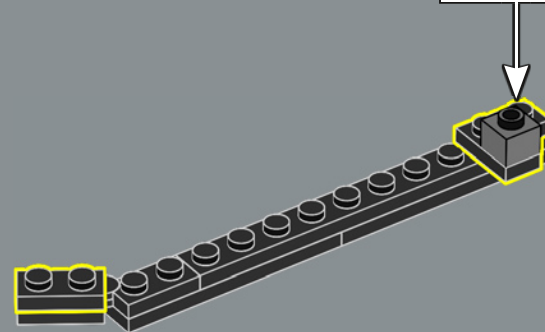
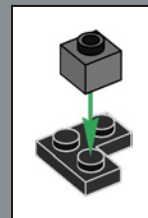

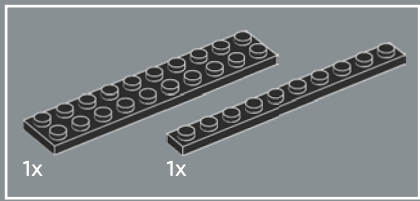

173

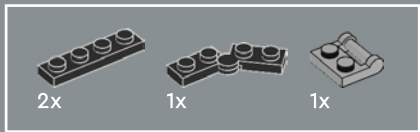
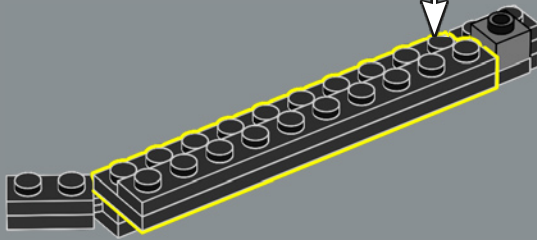
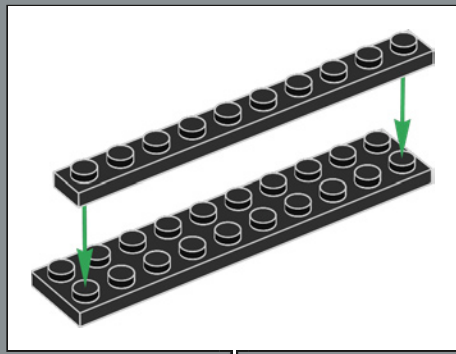

174

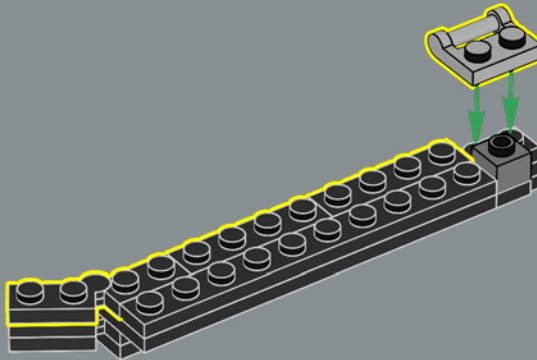

175

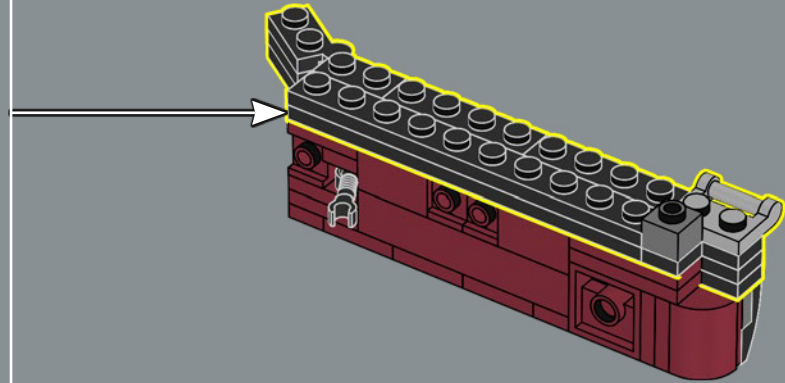

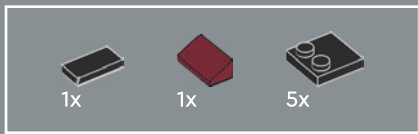

176

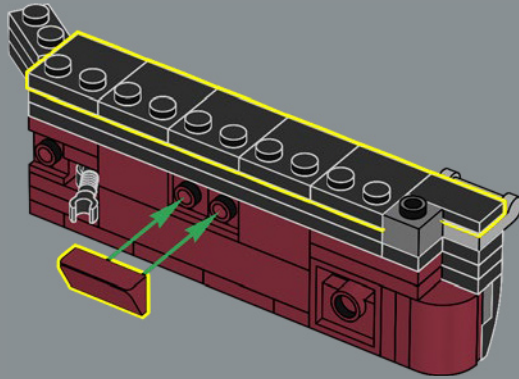

177

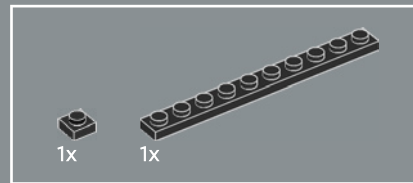
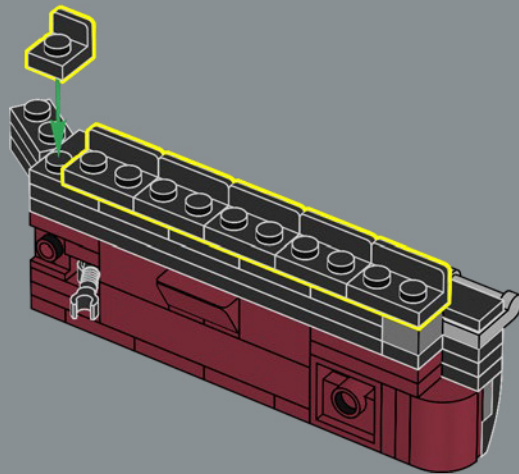

178

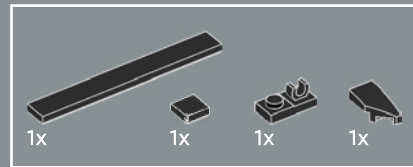
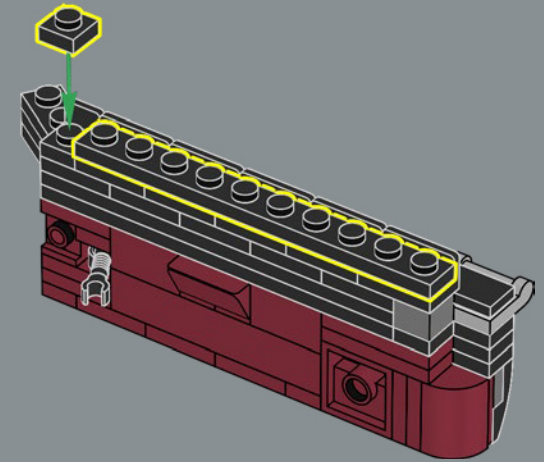

179

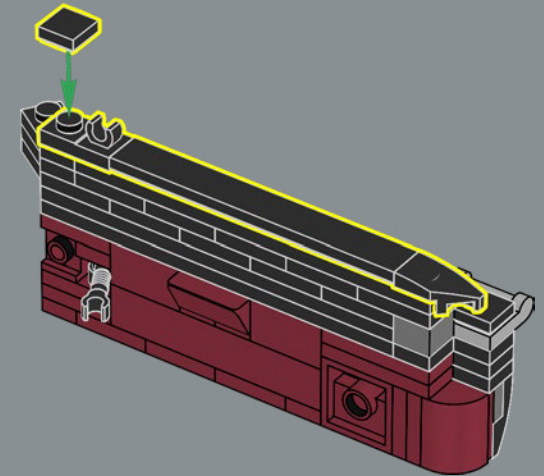



6x

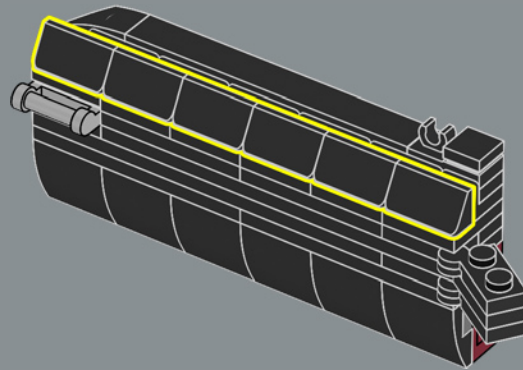

180

181

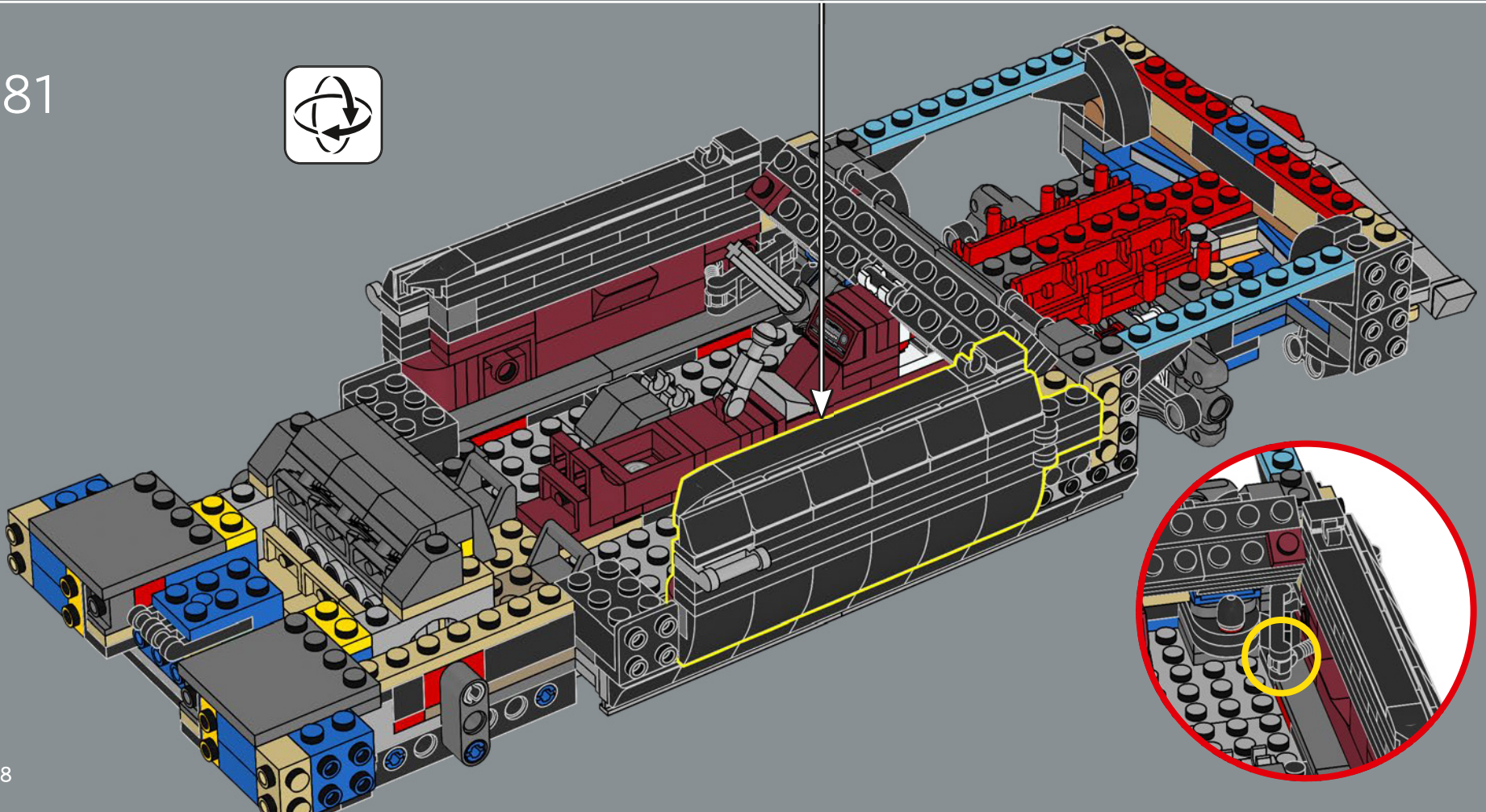



Sumando todos los modelos y paquetes,
los compradores del Camaro original
podían elegir entre 80 opciones de
fábrica diferentes.

182

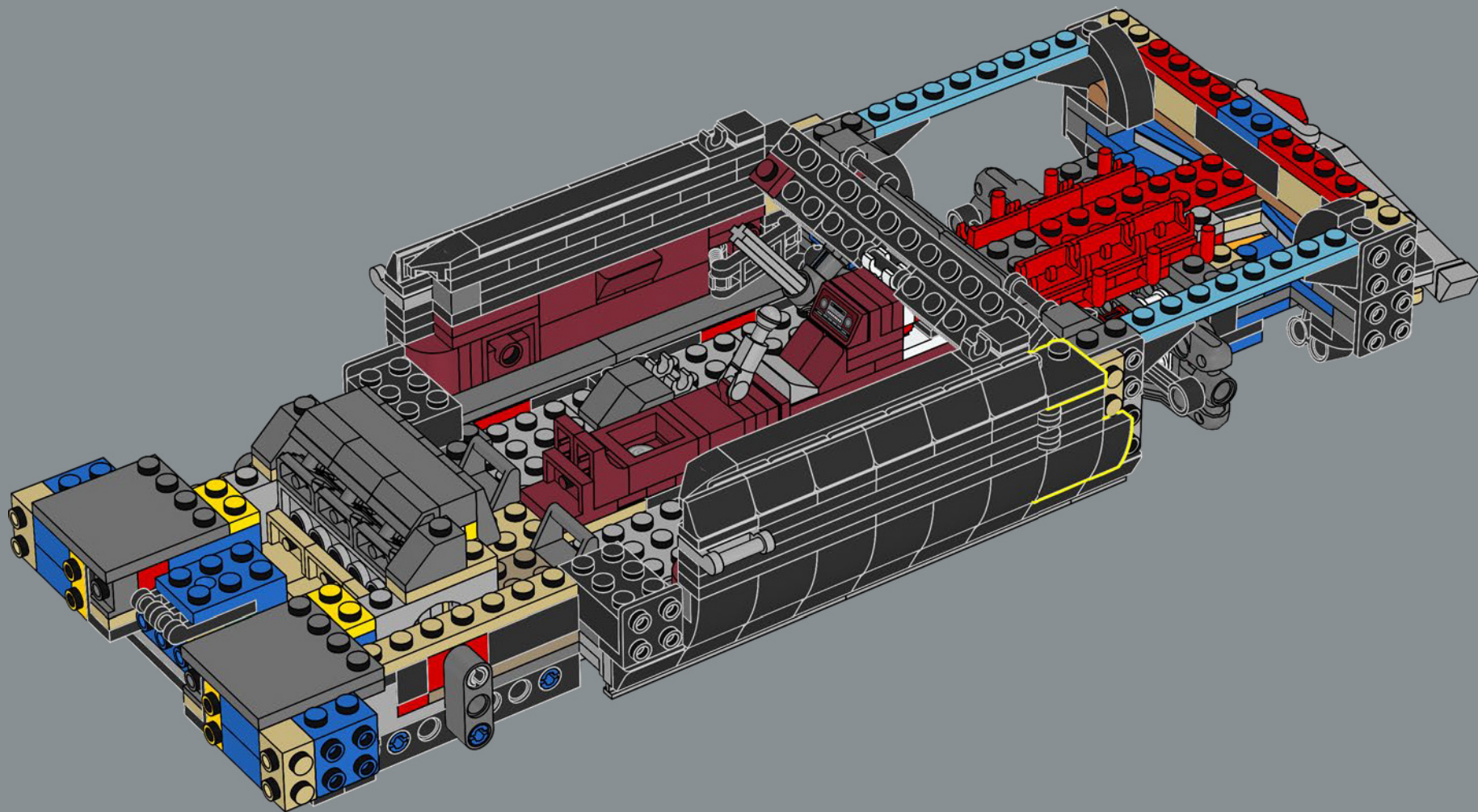

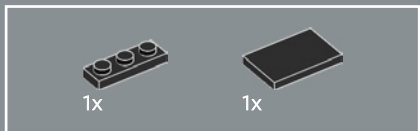

183

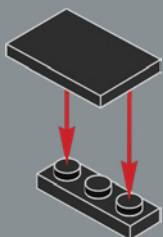

184

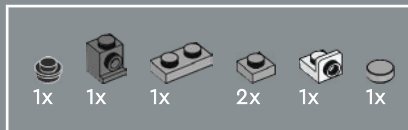
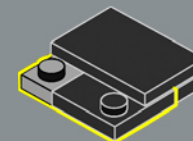

185

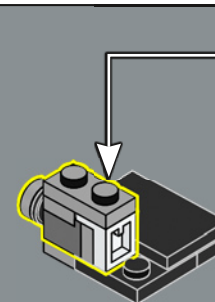
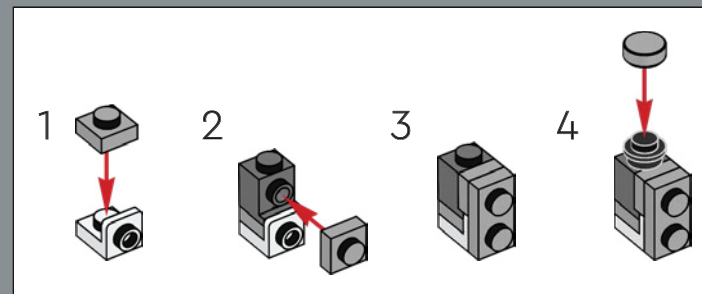

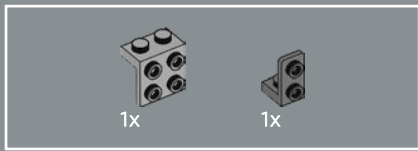

186

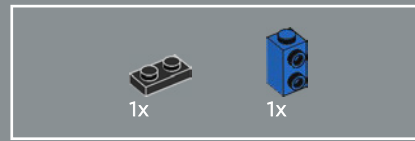
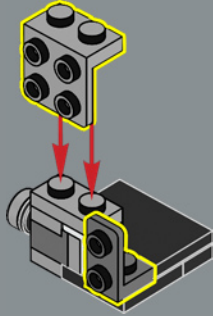

187

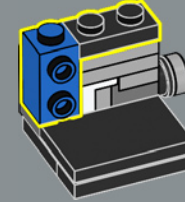

188

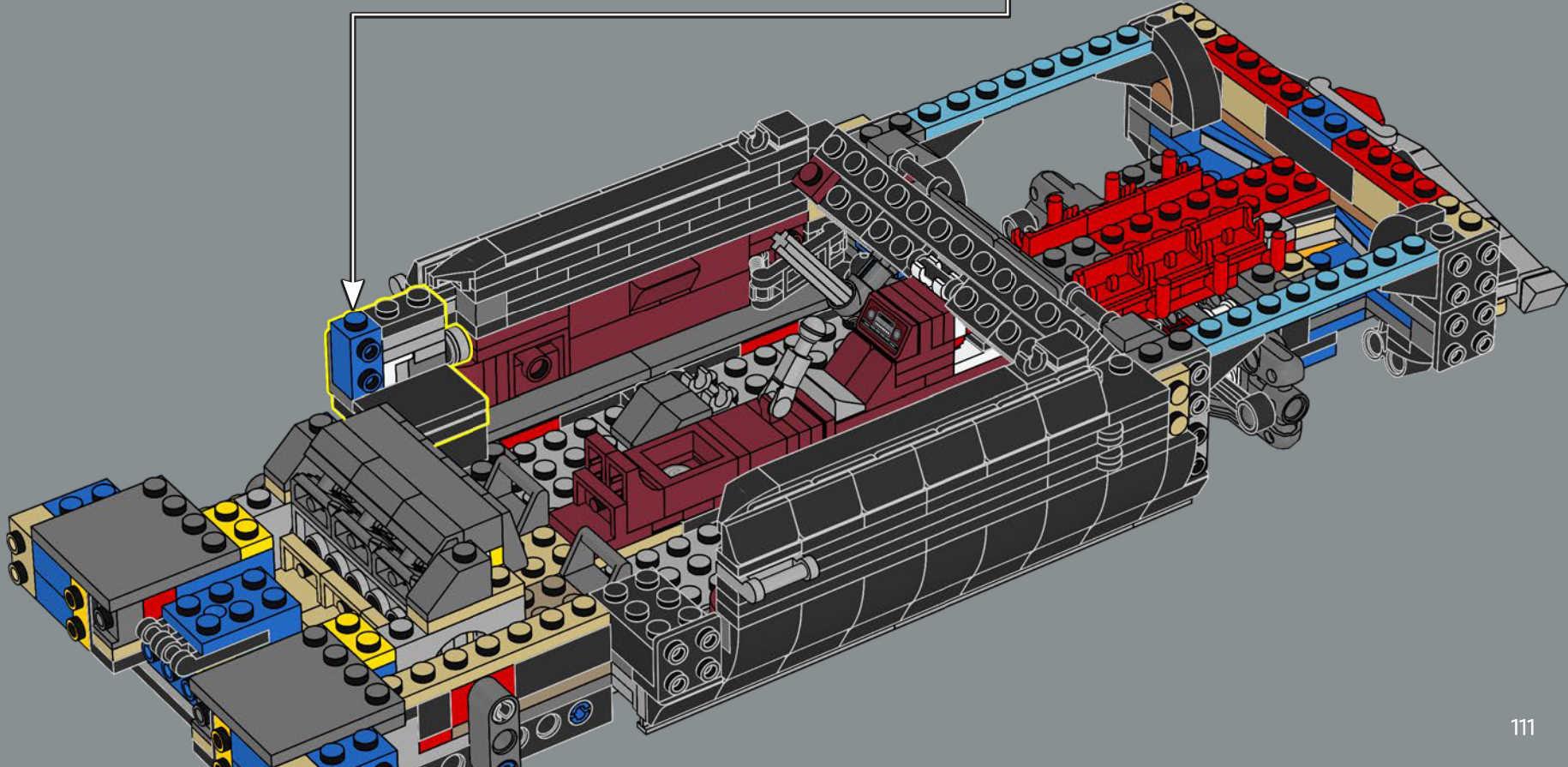

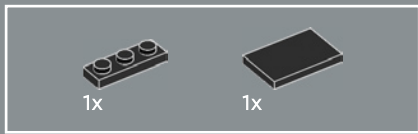

189

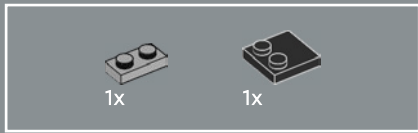
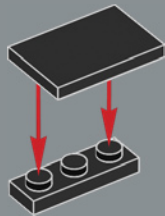

190

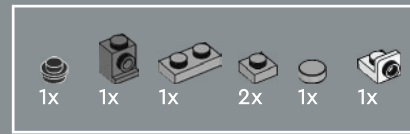
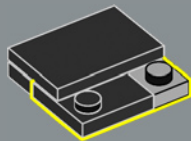

191

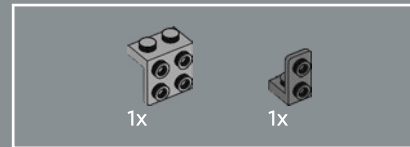
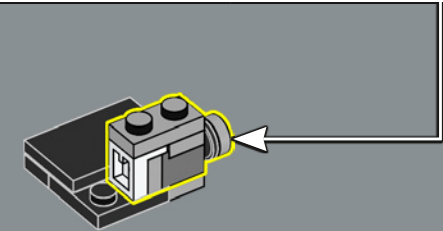
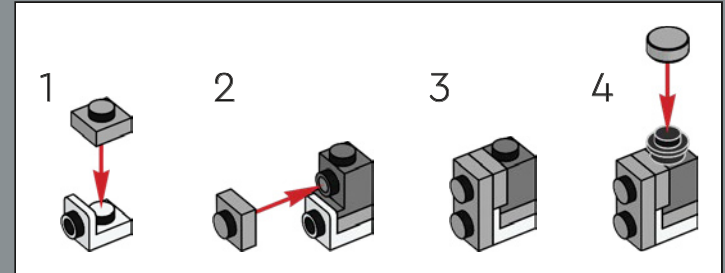

192

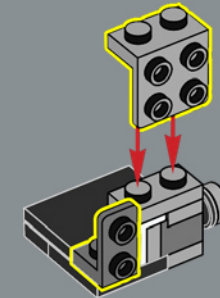

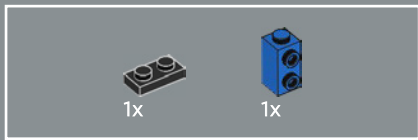

193

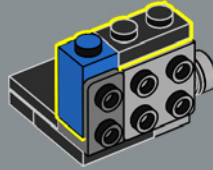

194

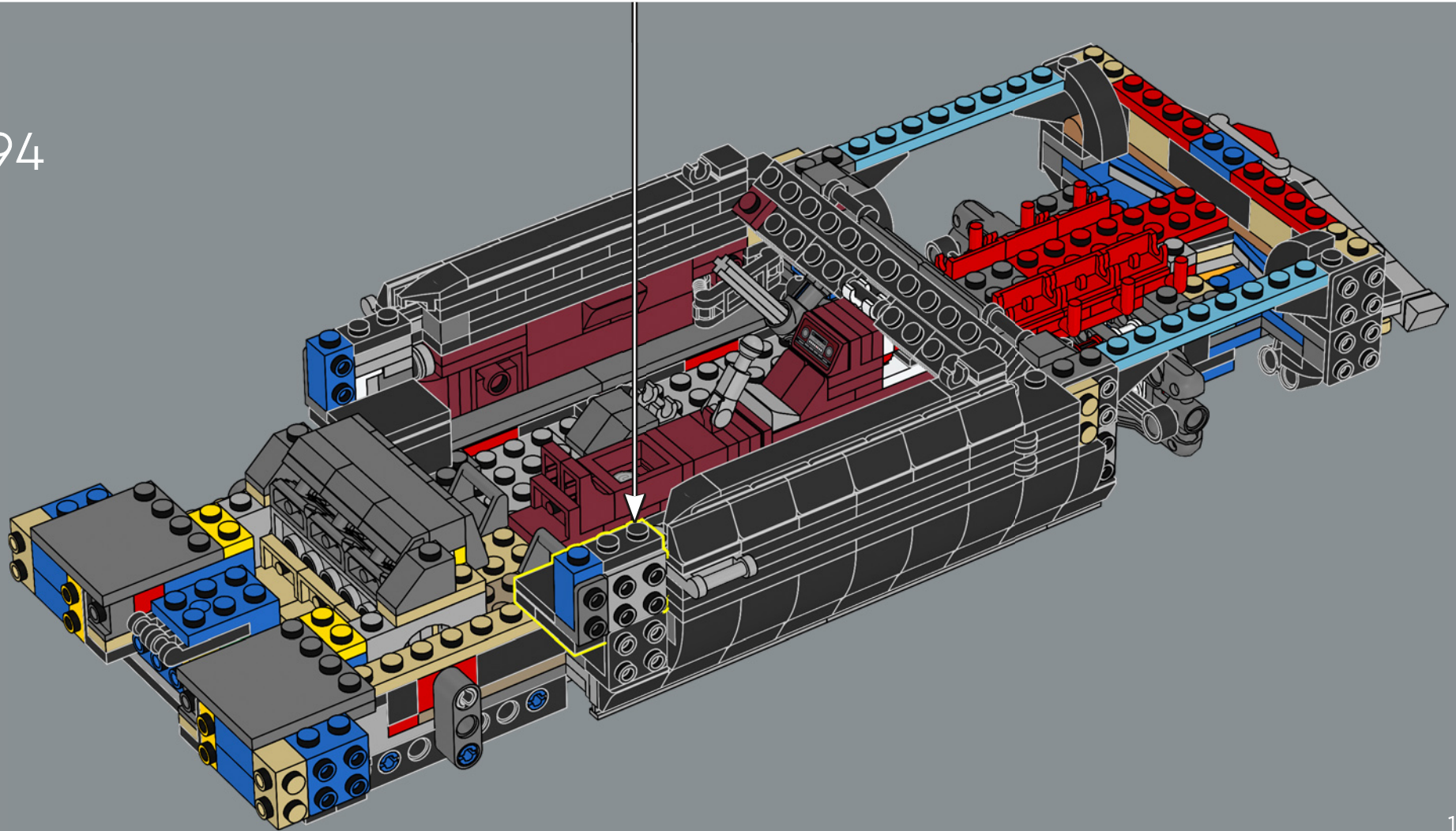

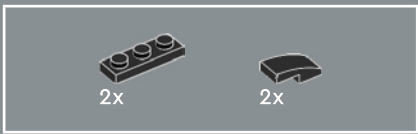

195

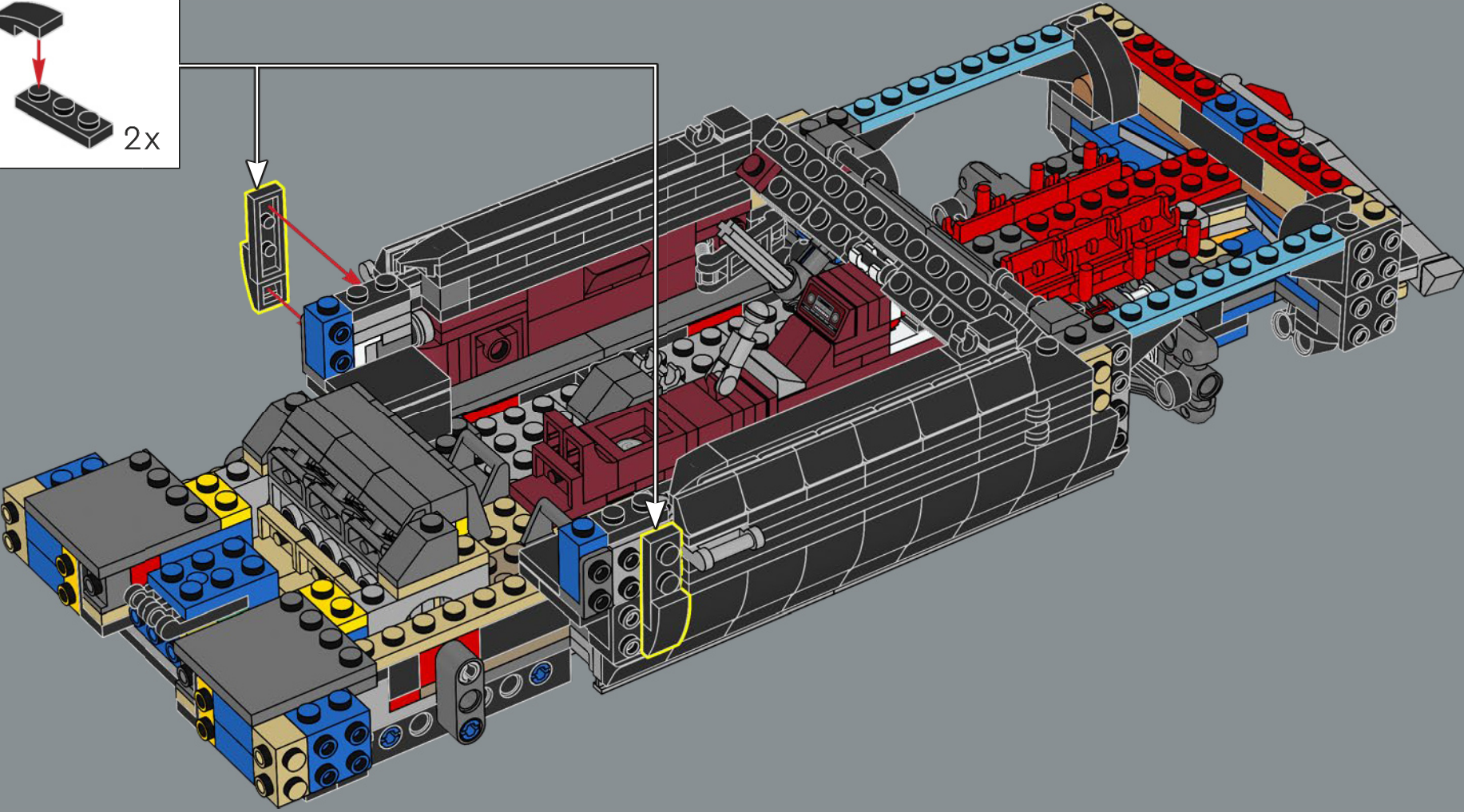
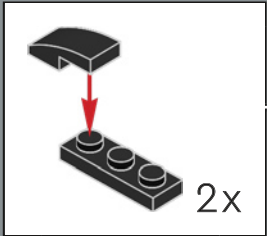

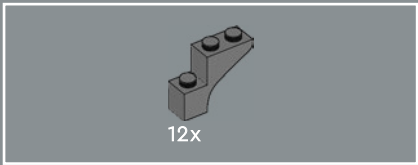

196

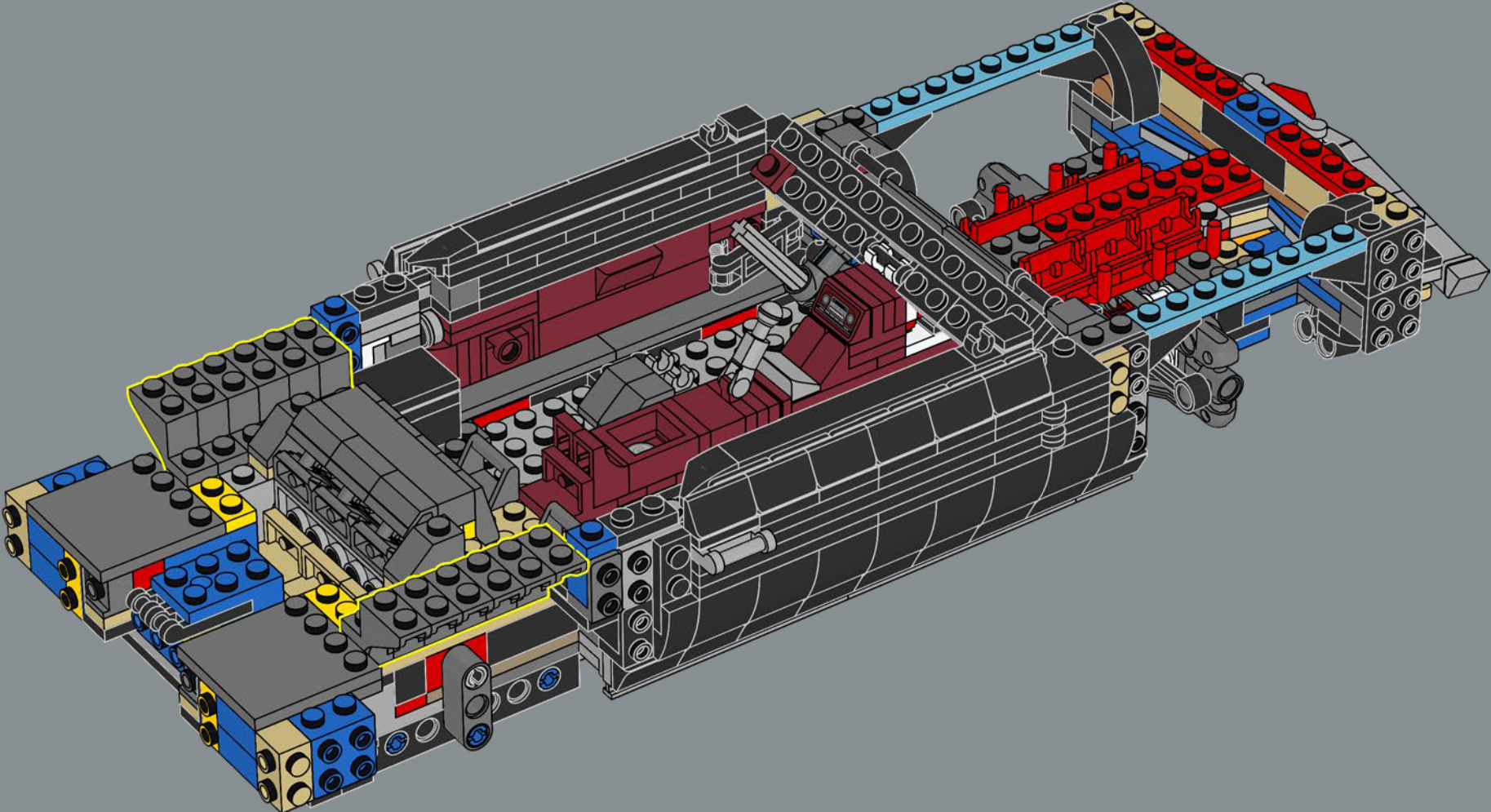

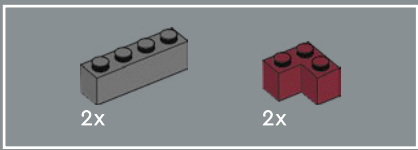

197

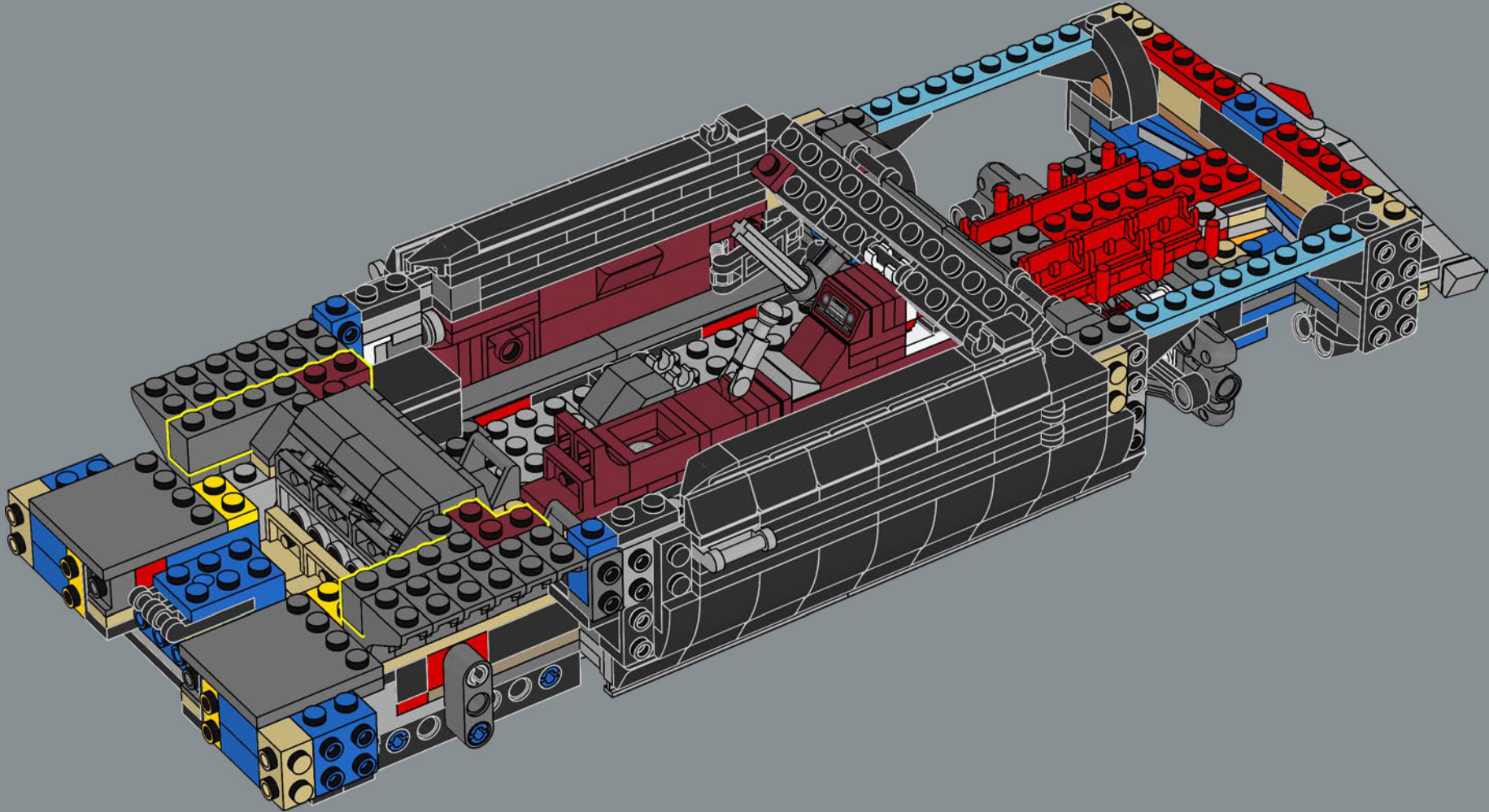

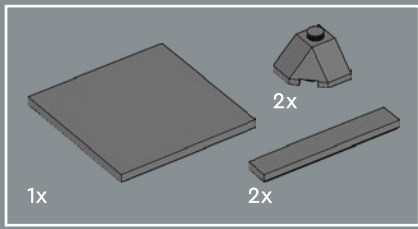

198

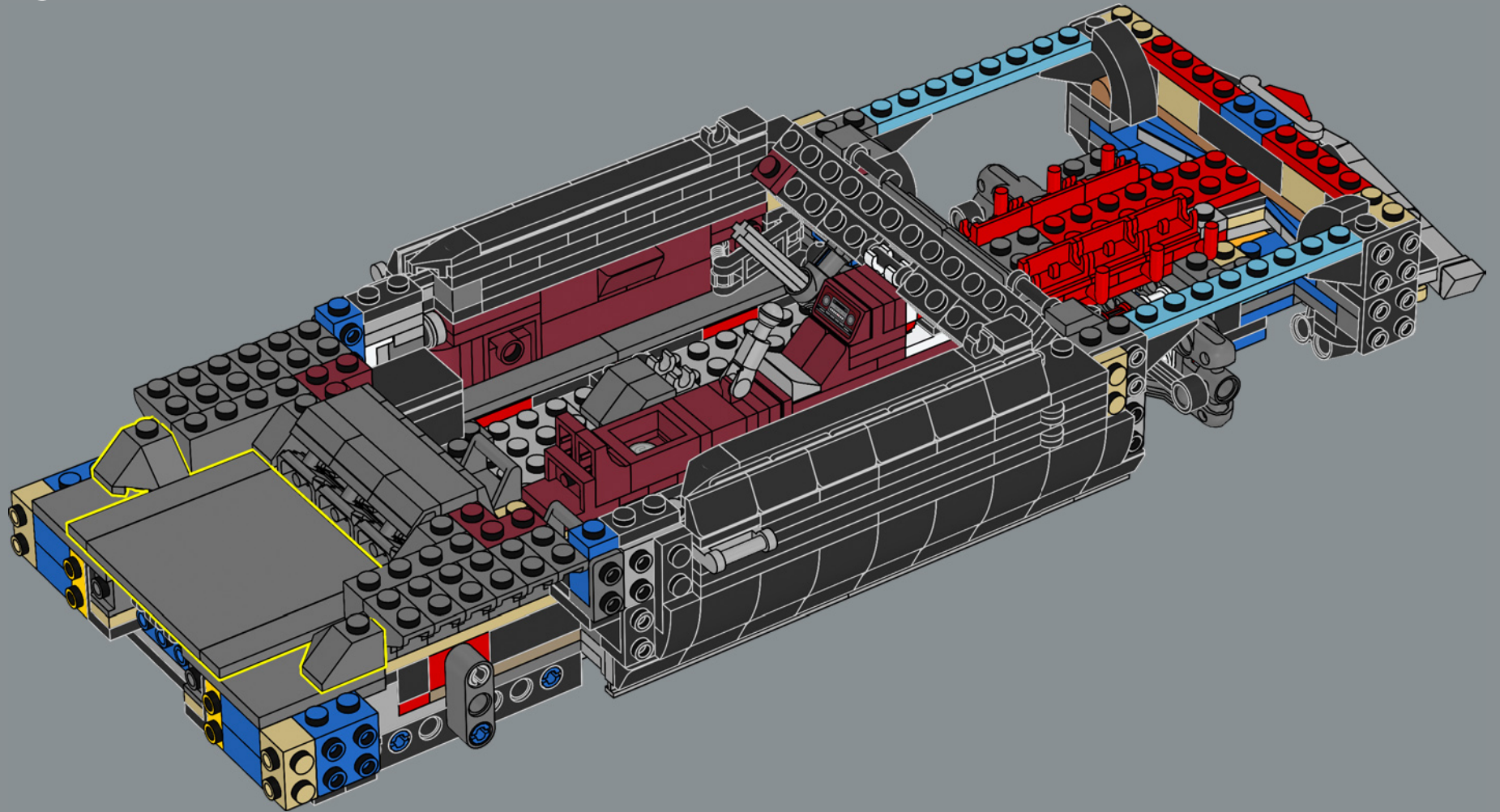

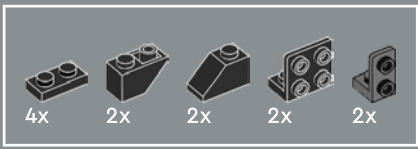

199

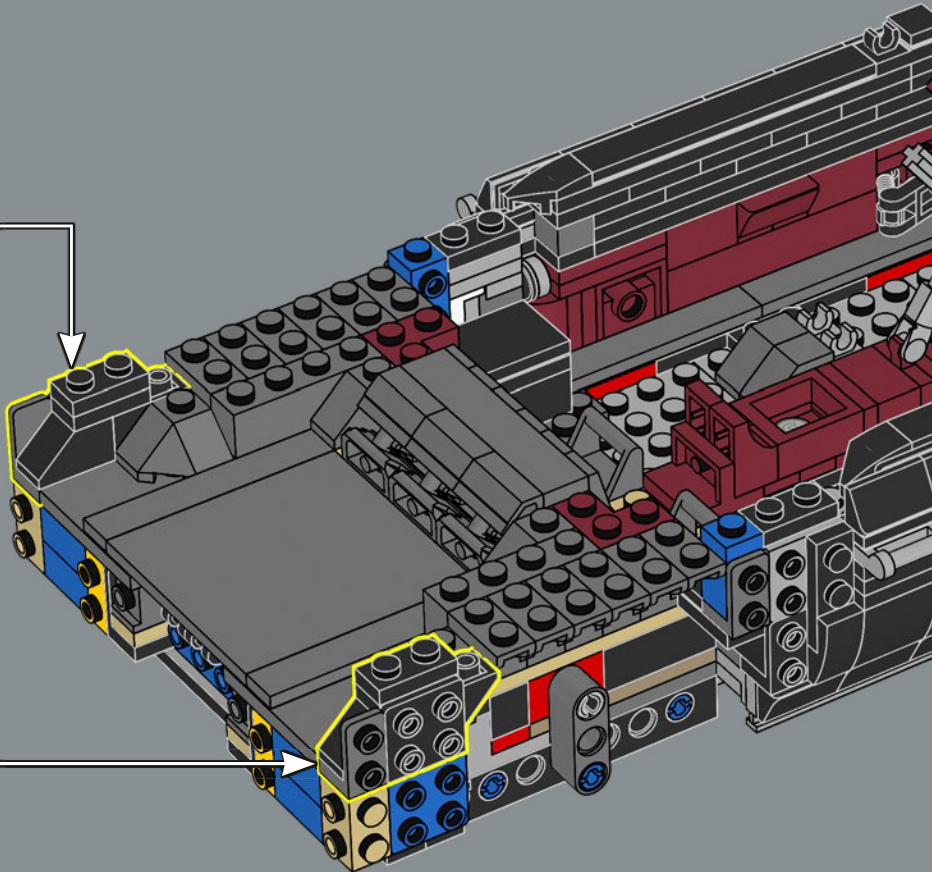
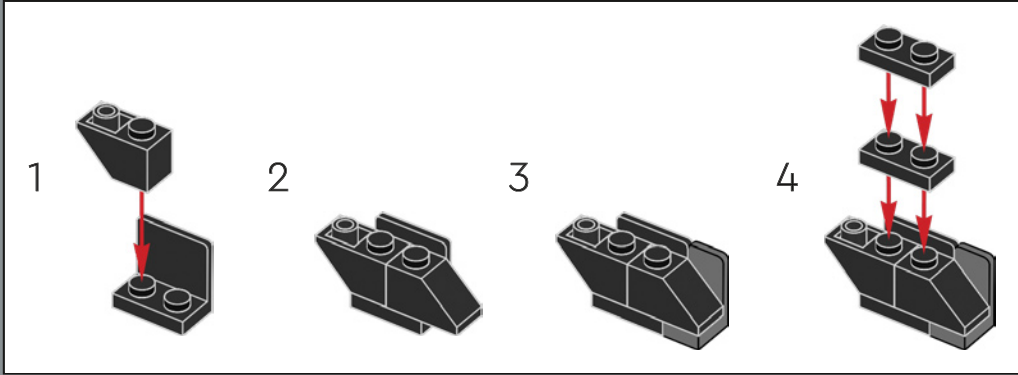
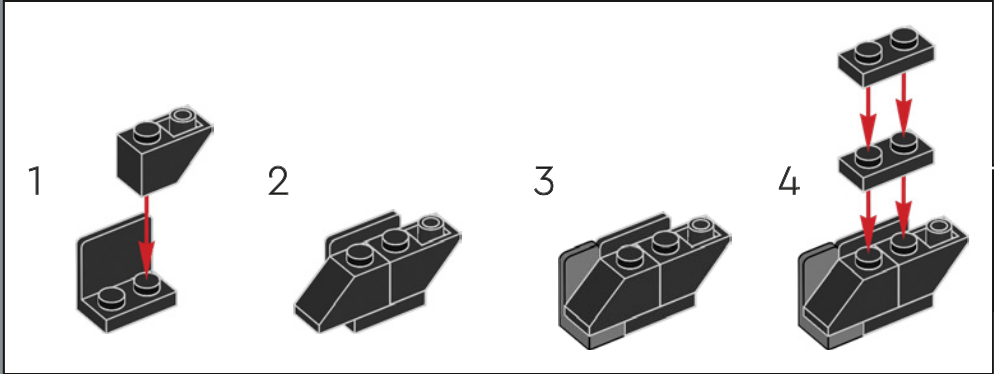



200

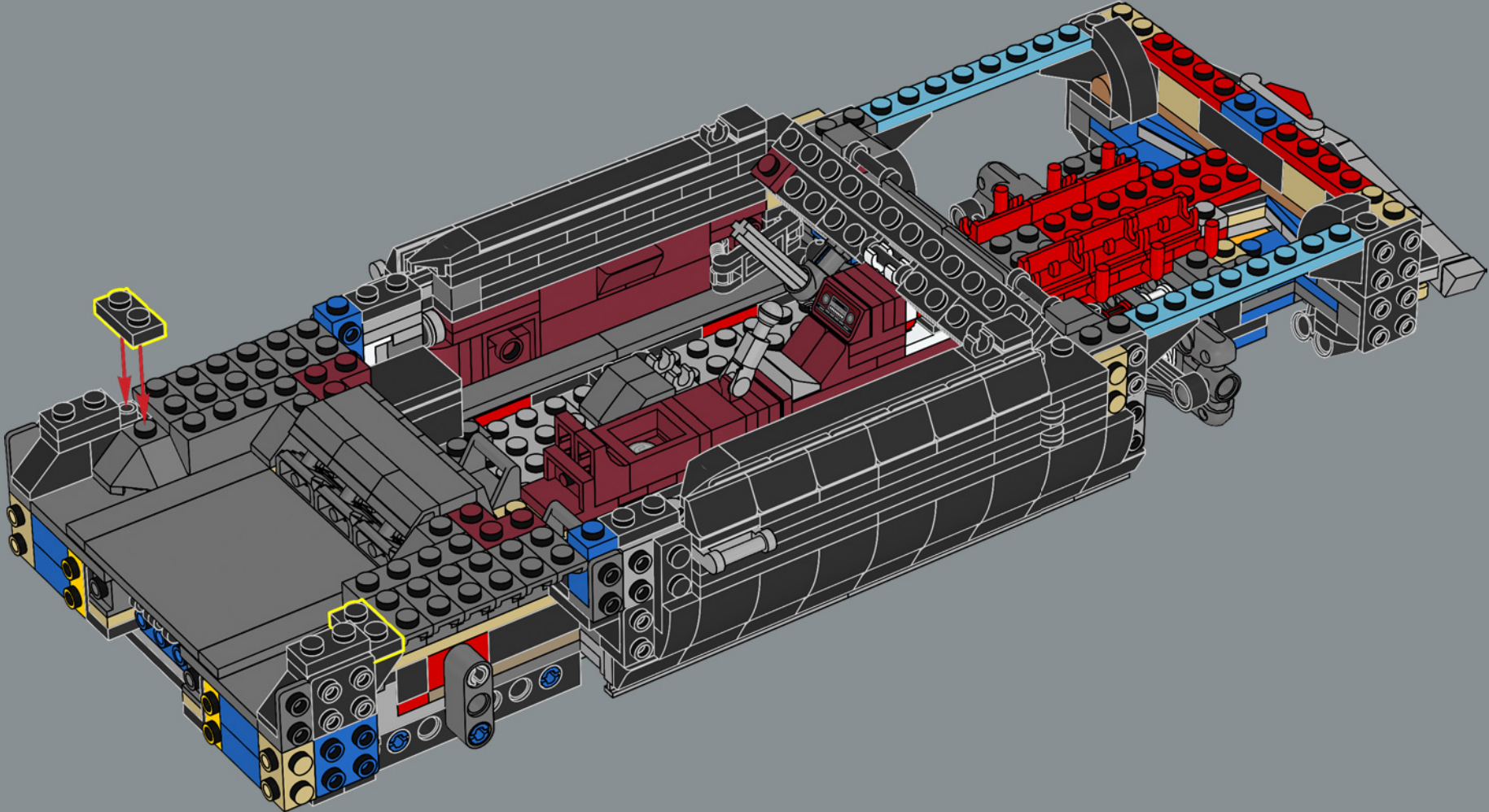

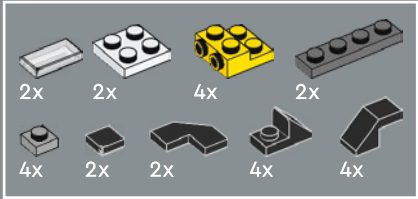

201

1

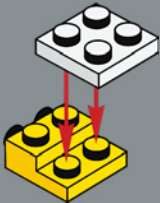

2

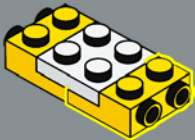

3

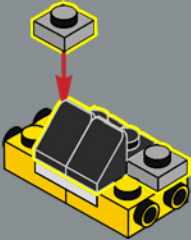

4

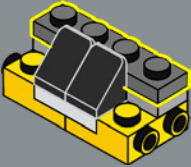

5

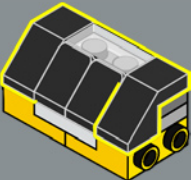

2x

6

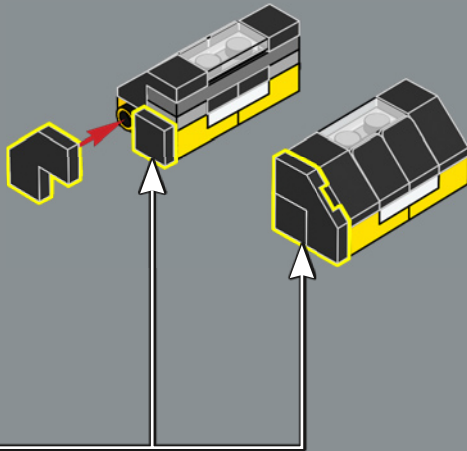

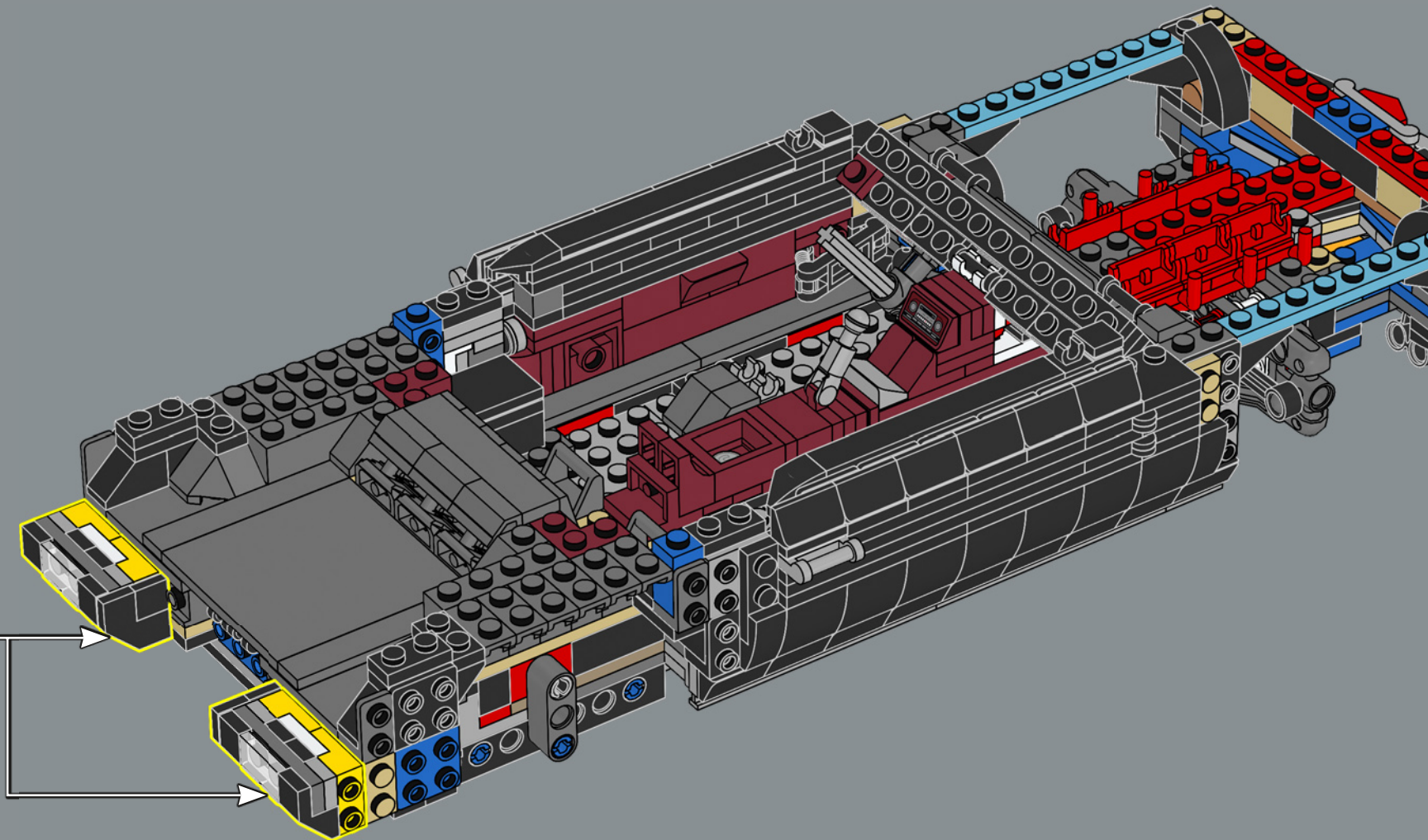



202

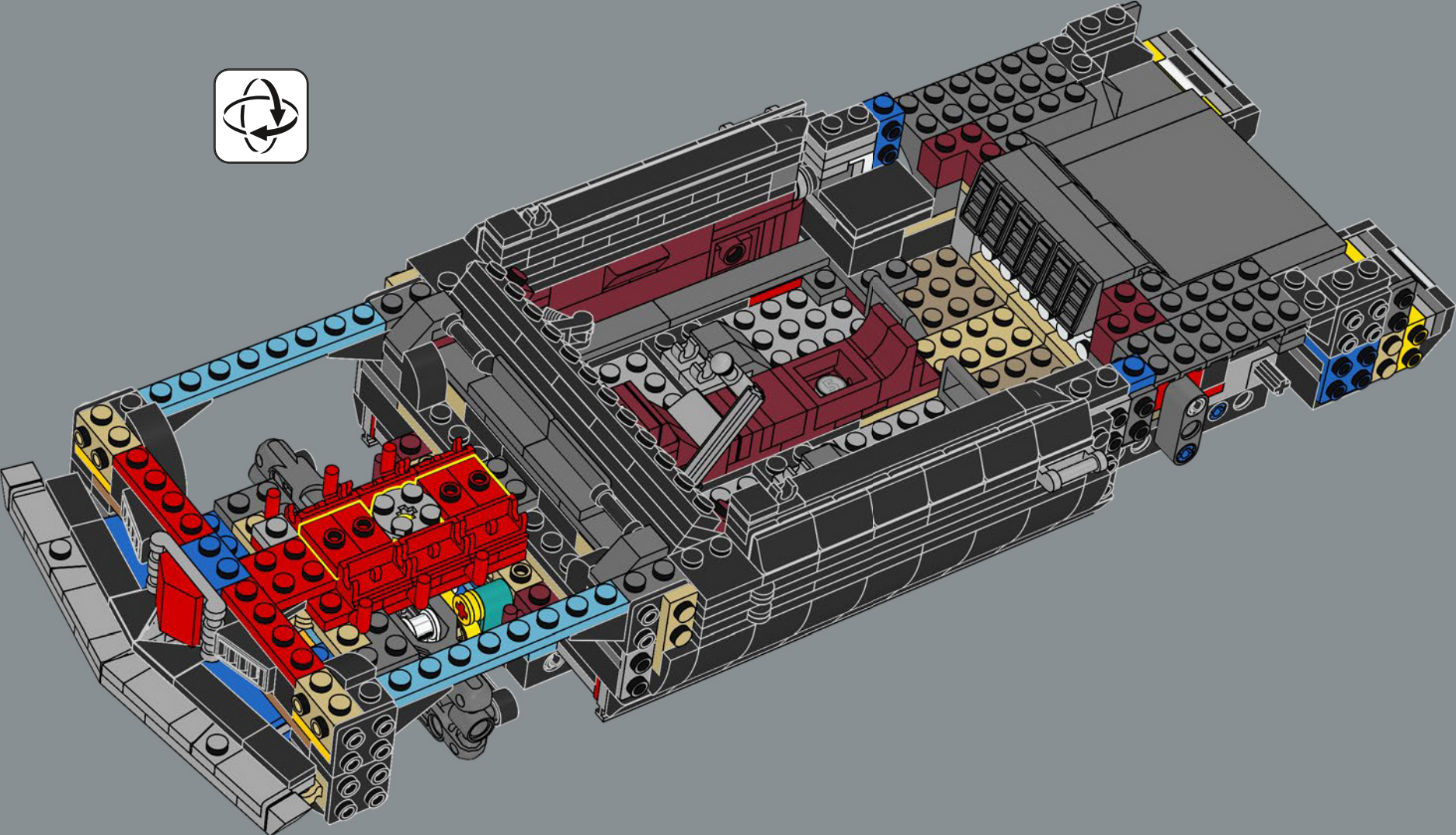

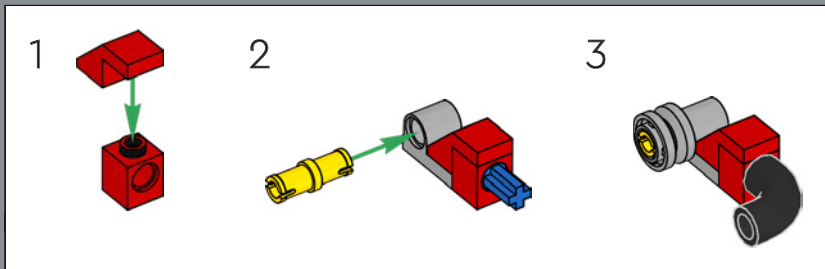
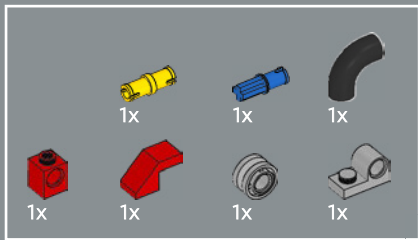

203

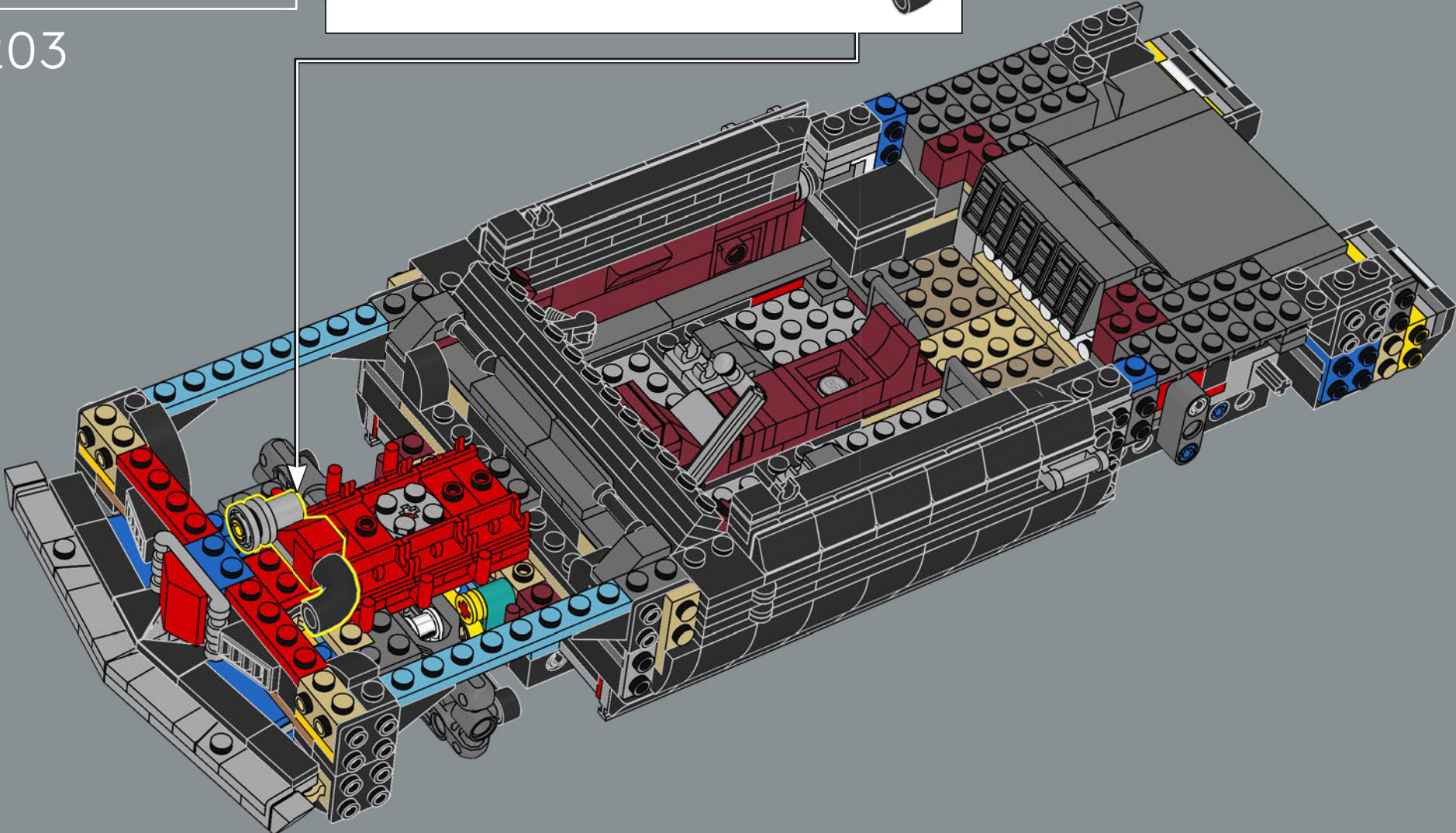

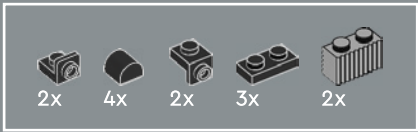

204

1

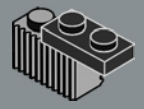

2

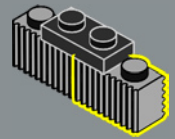

3

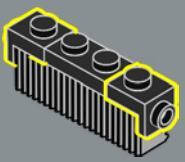

4

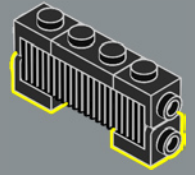

5

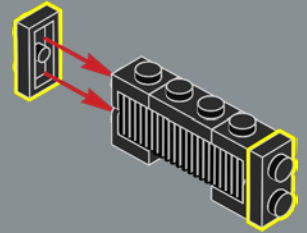

6

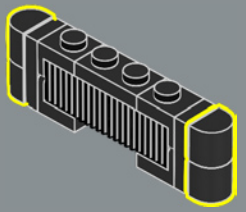

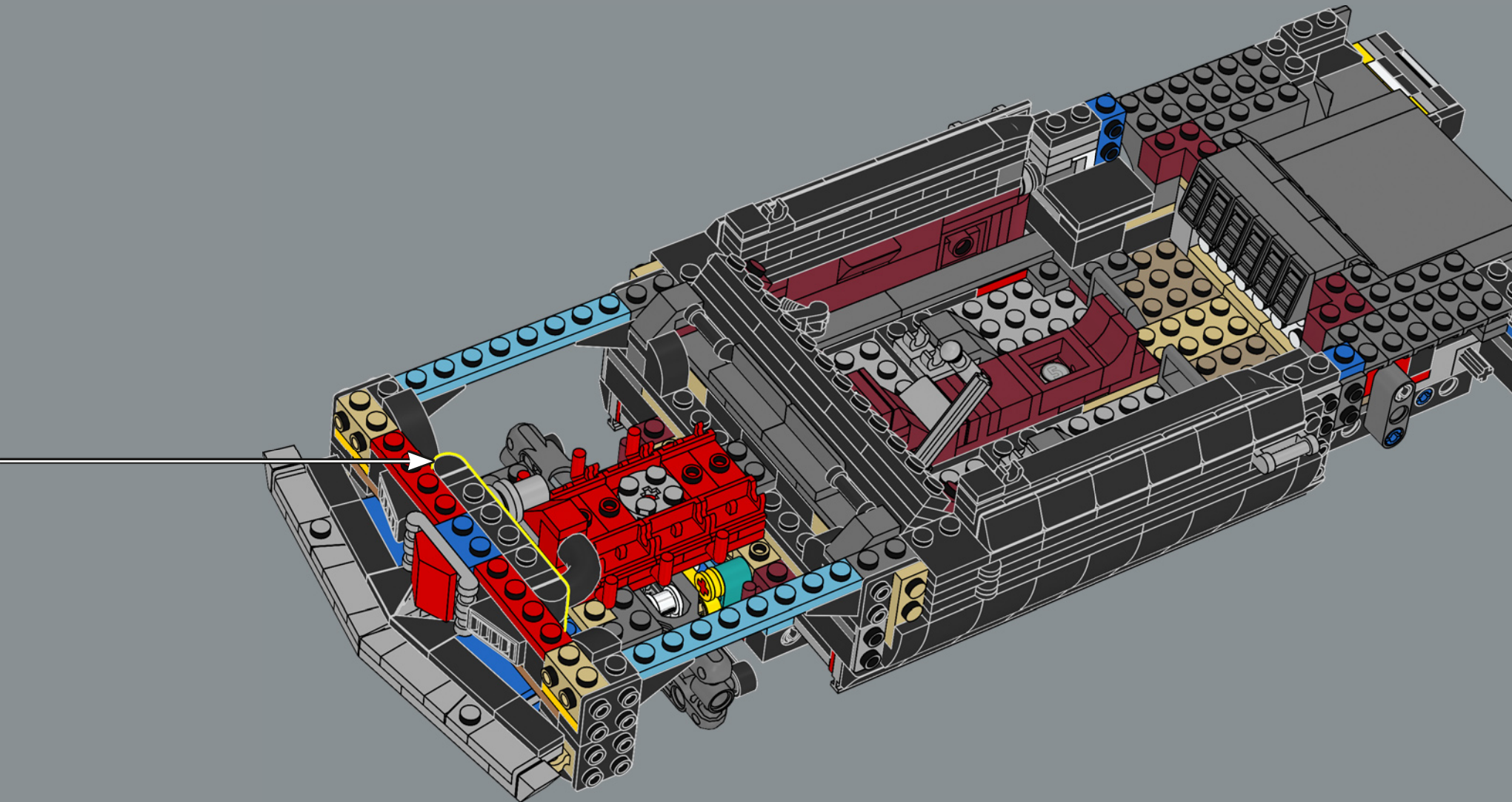

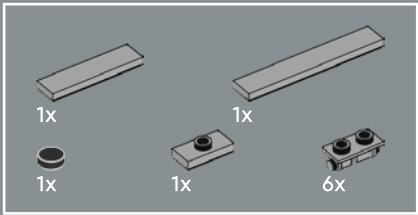

205

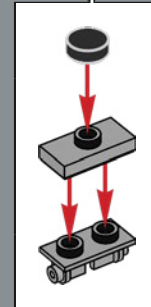
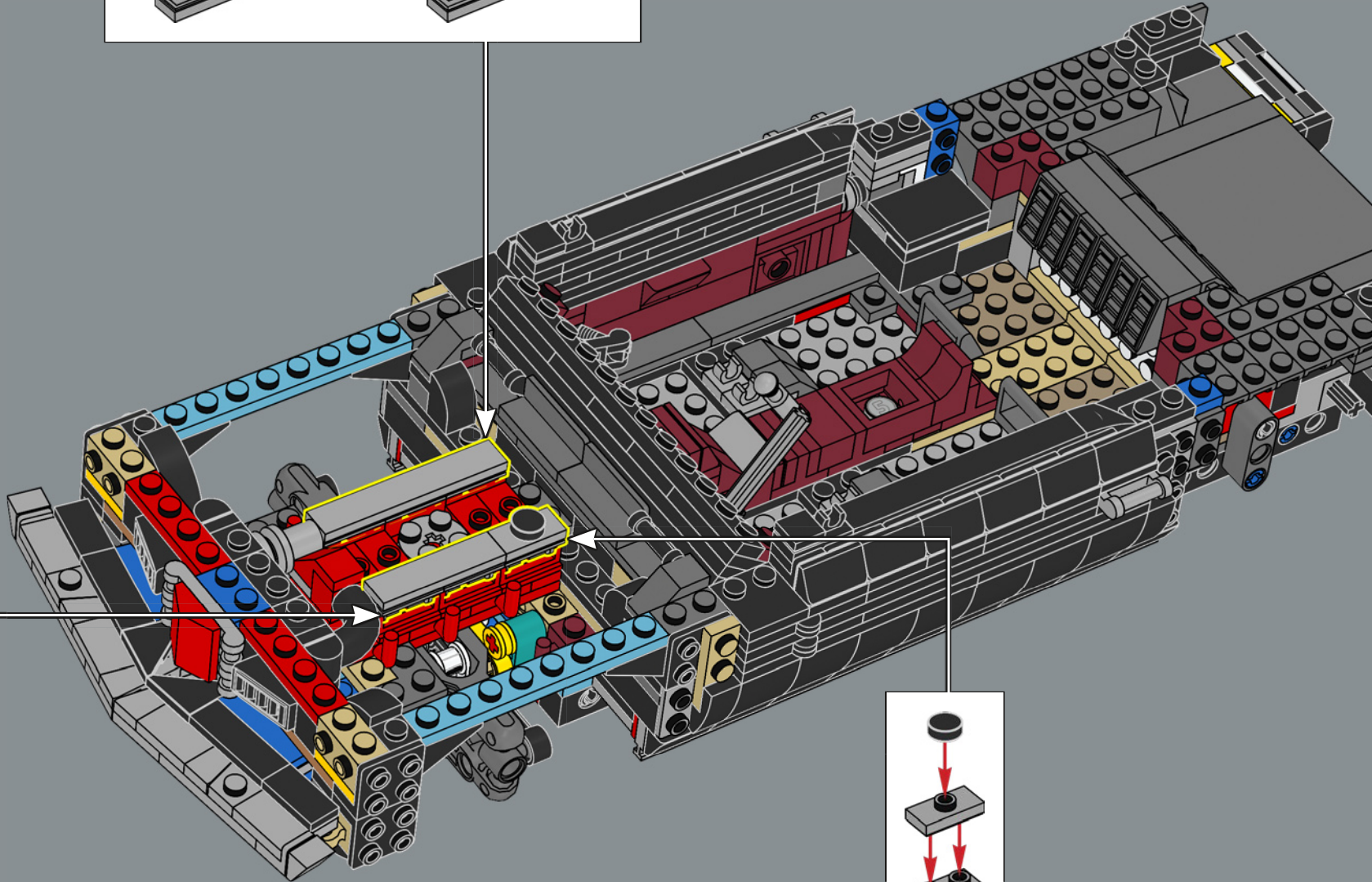
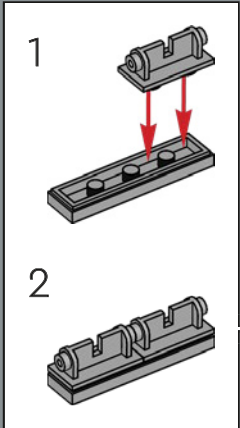
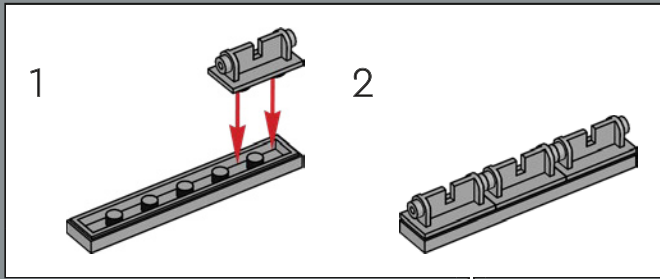

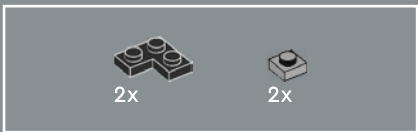

206

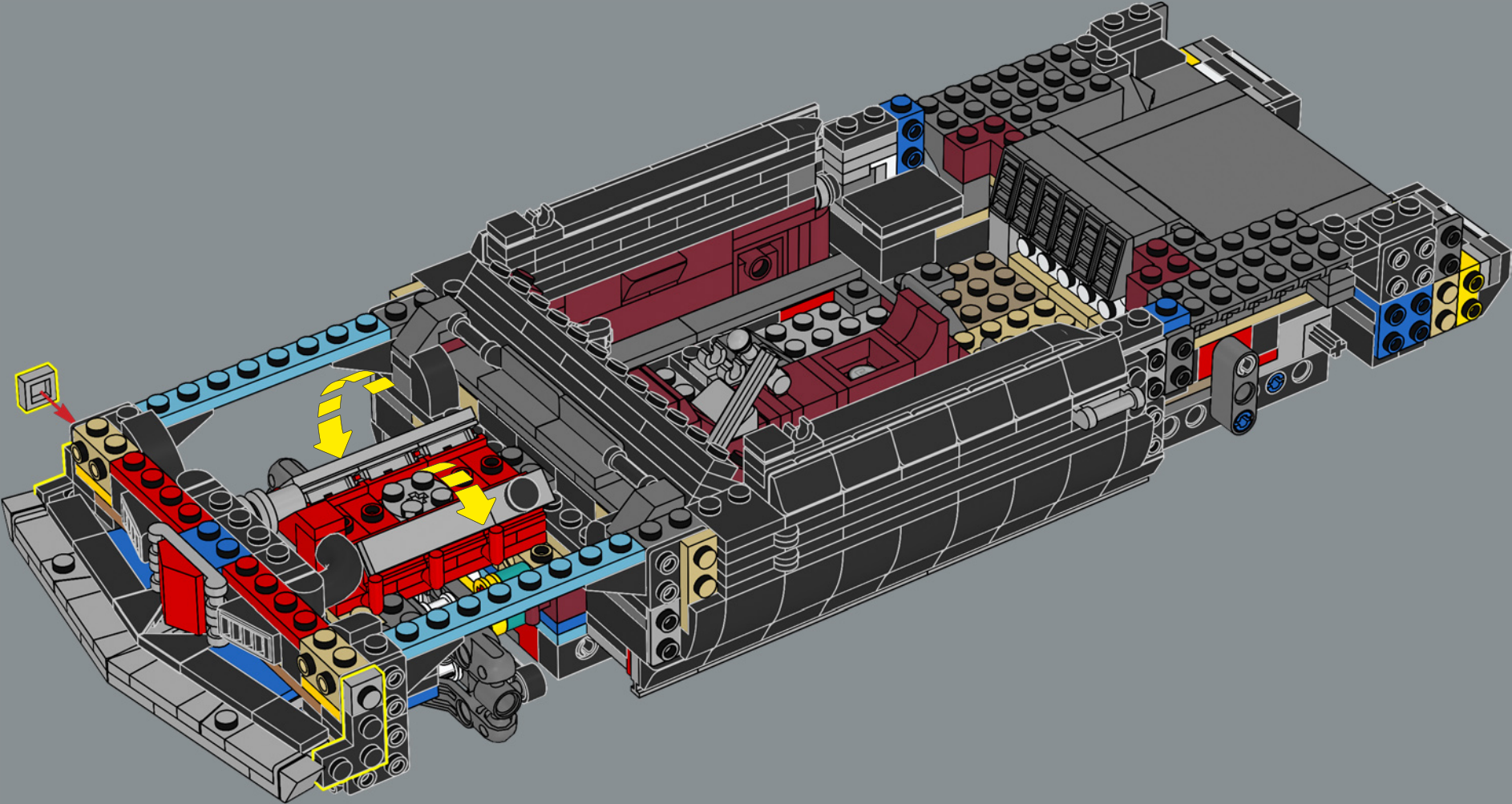



207

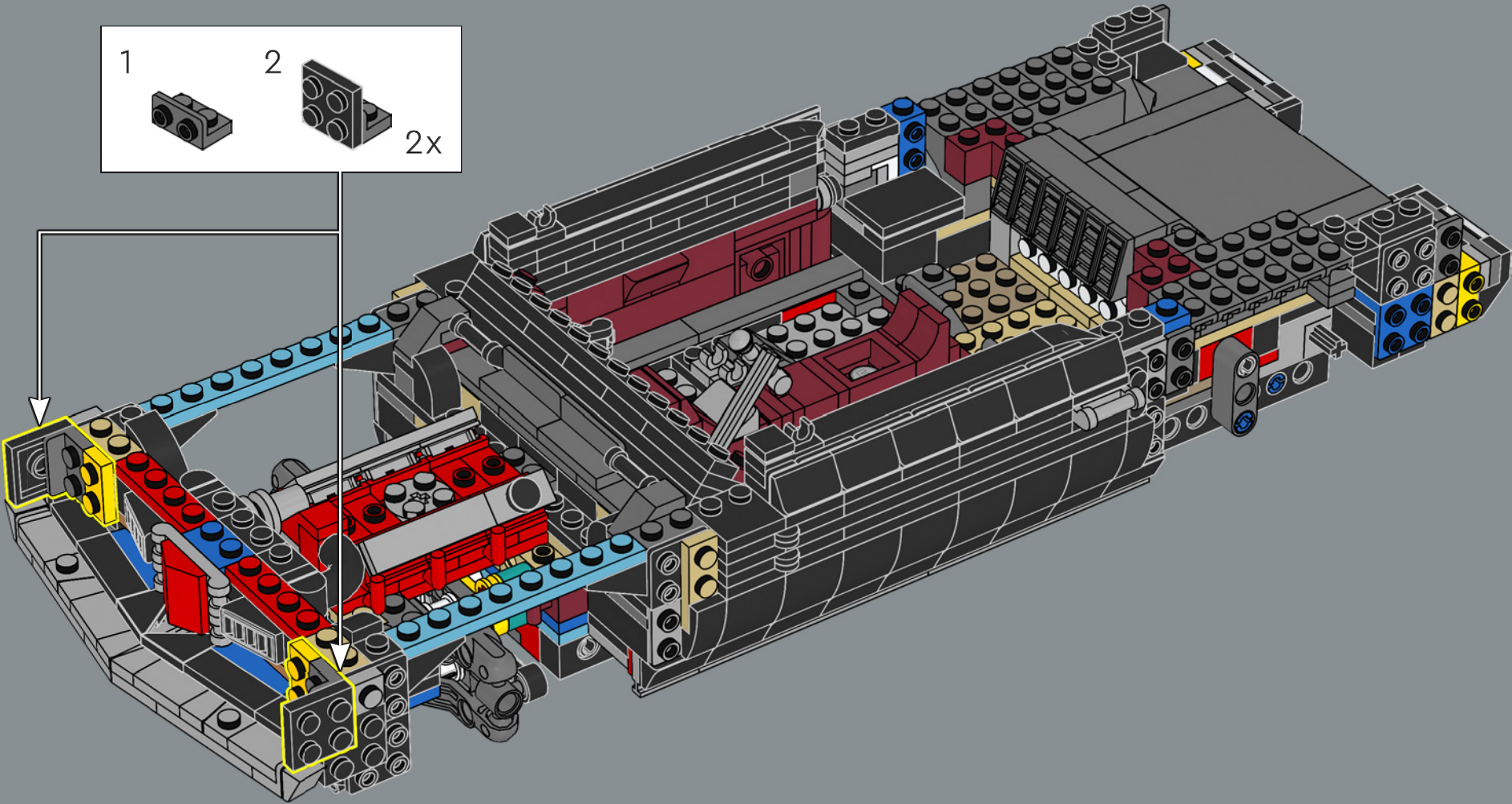
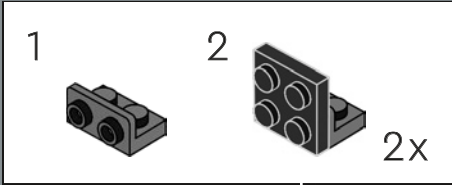

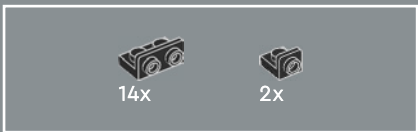

208

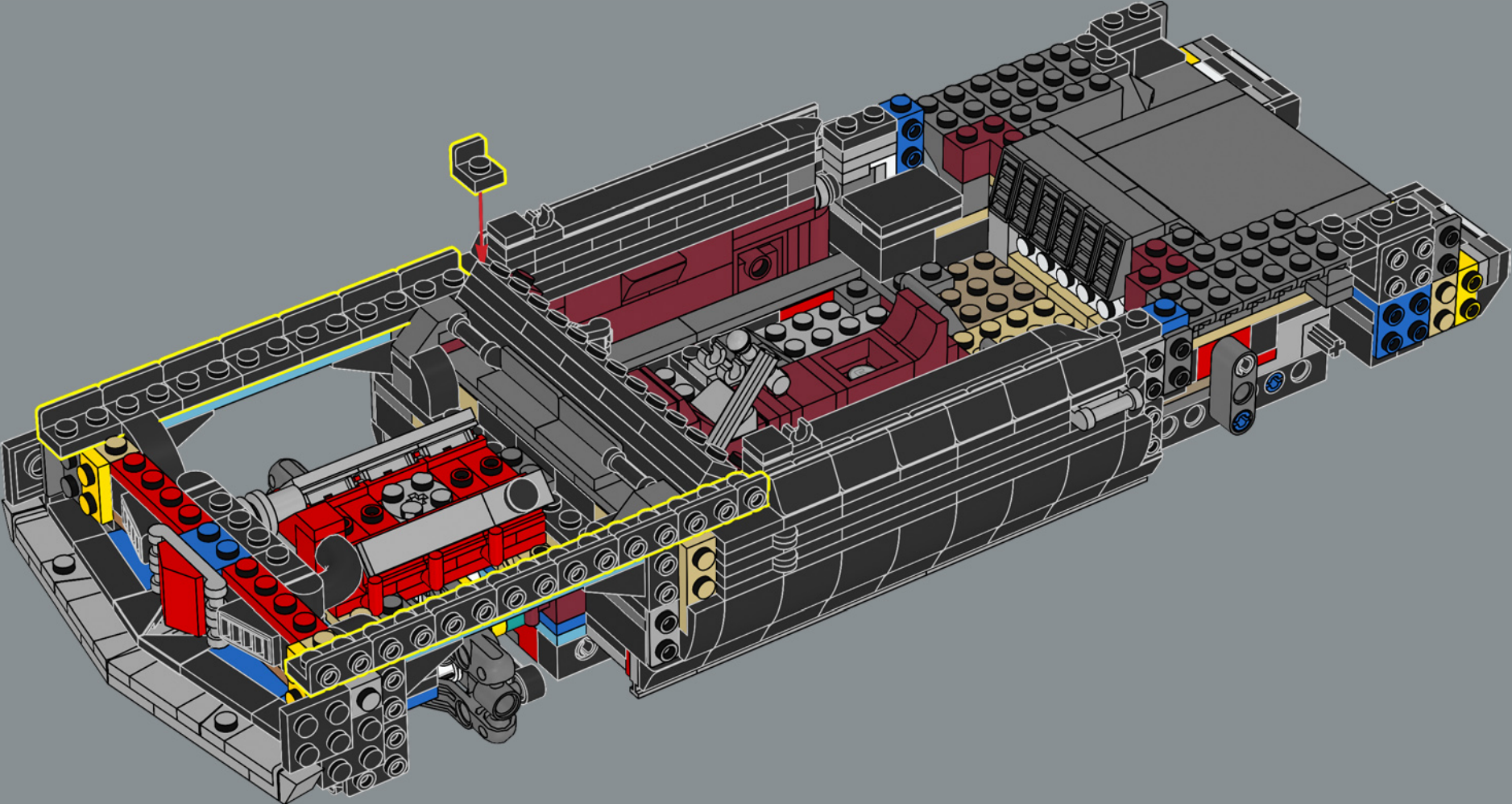

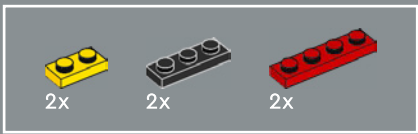

209

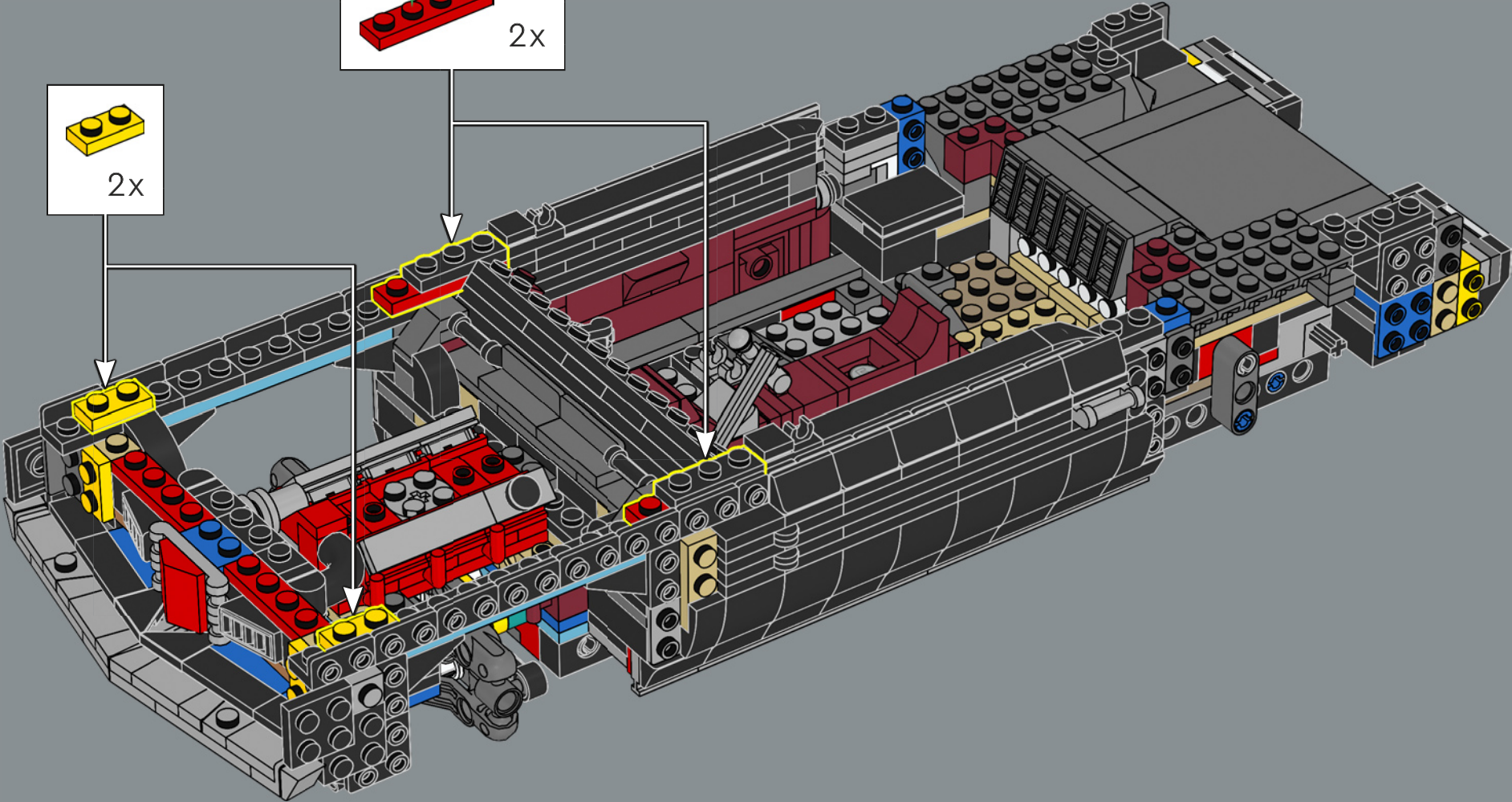
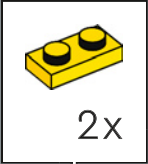
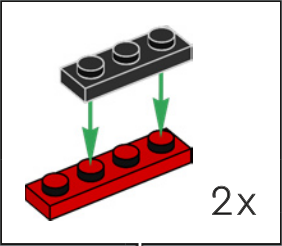



210

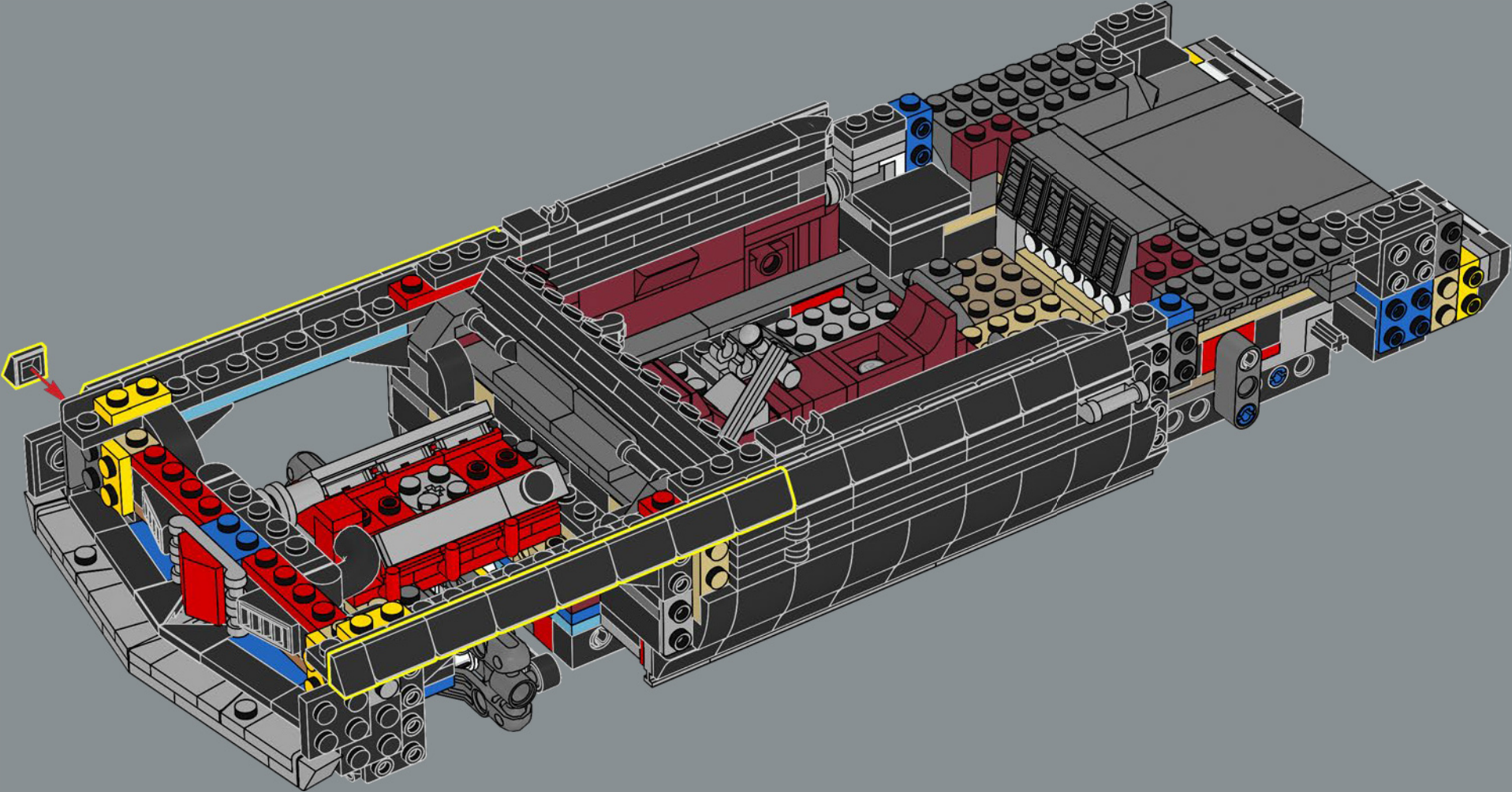

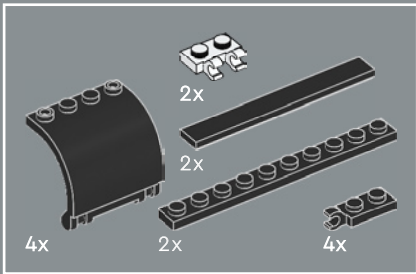
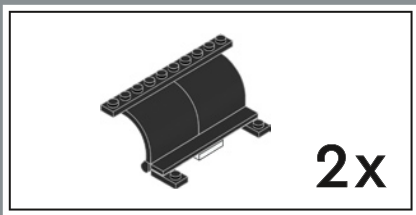

211

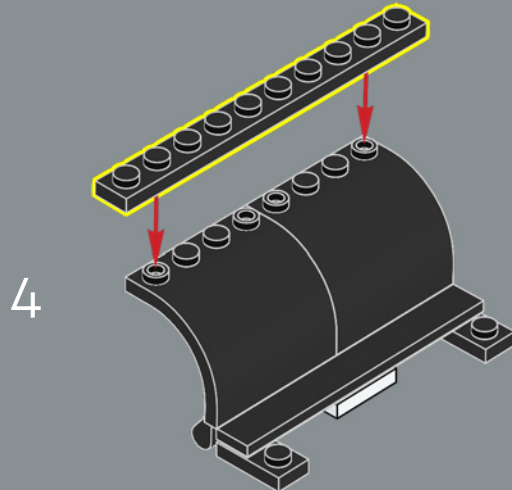
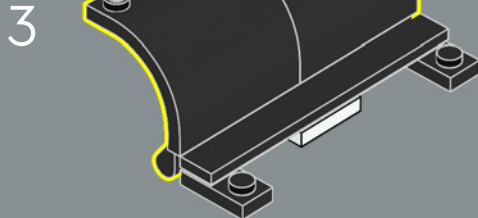
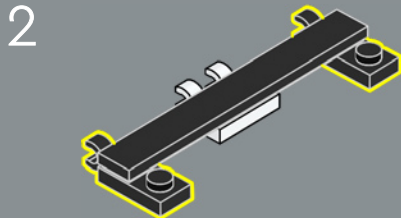
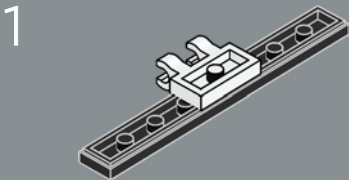

2x

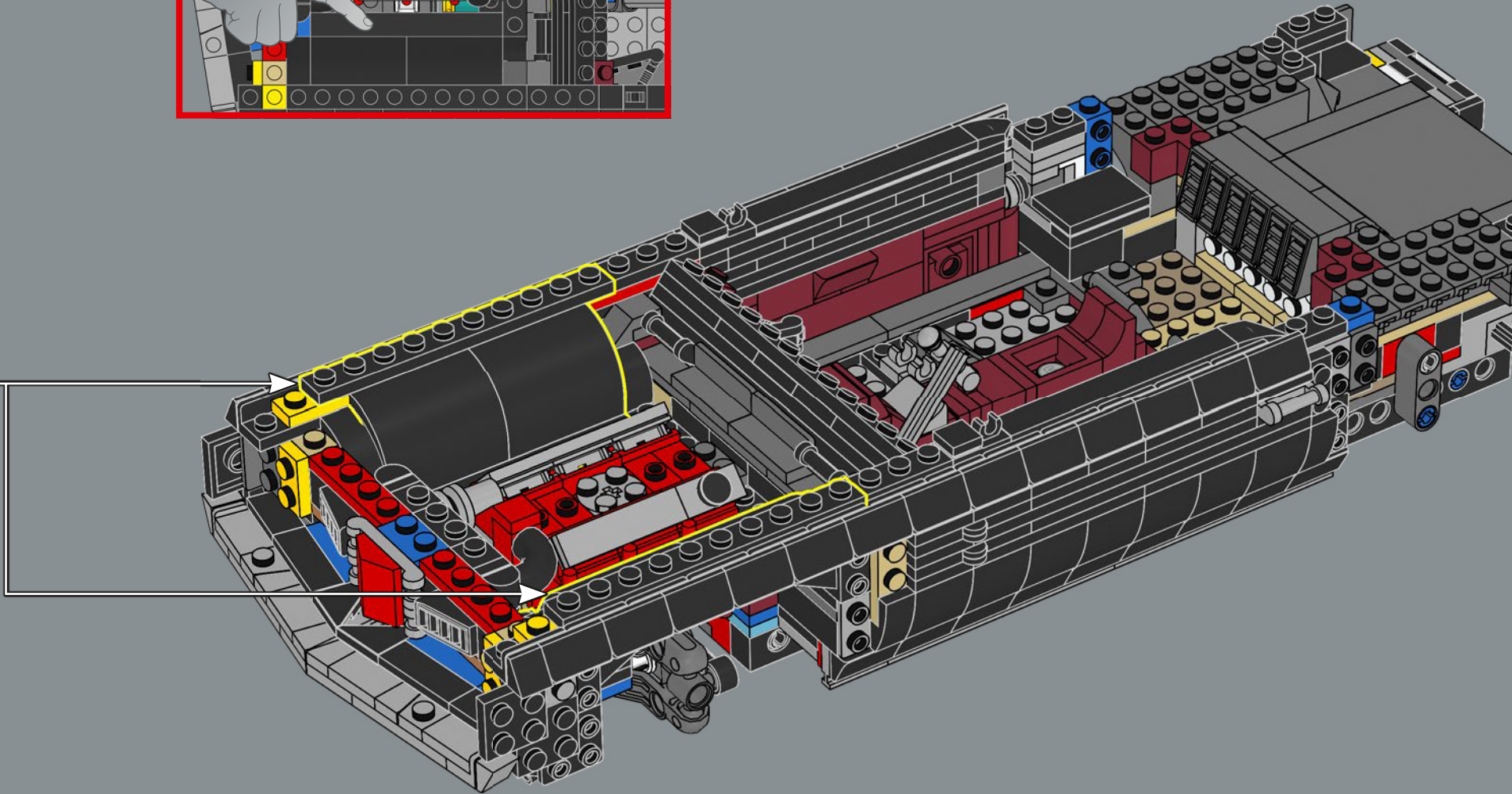
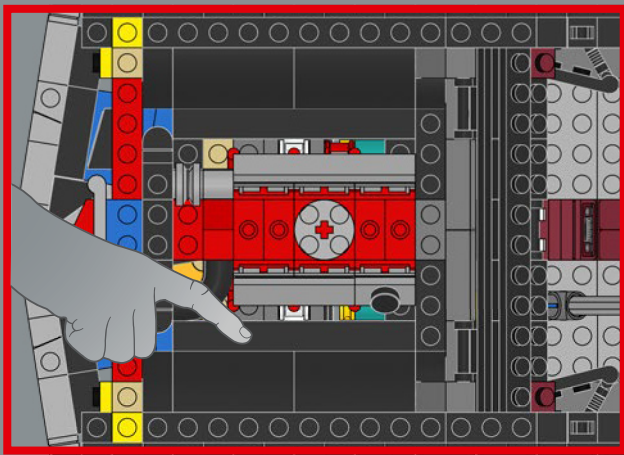

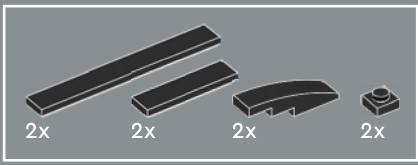

212

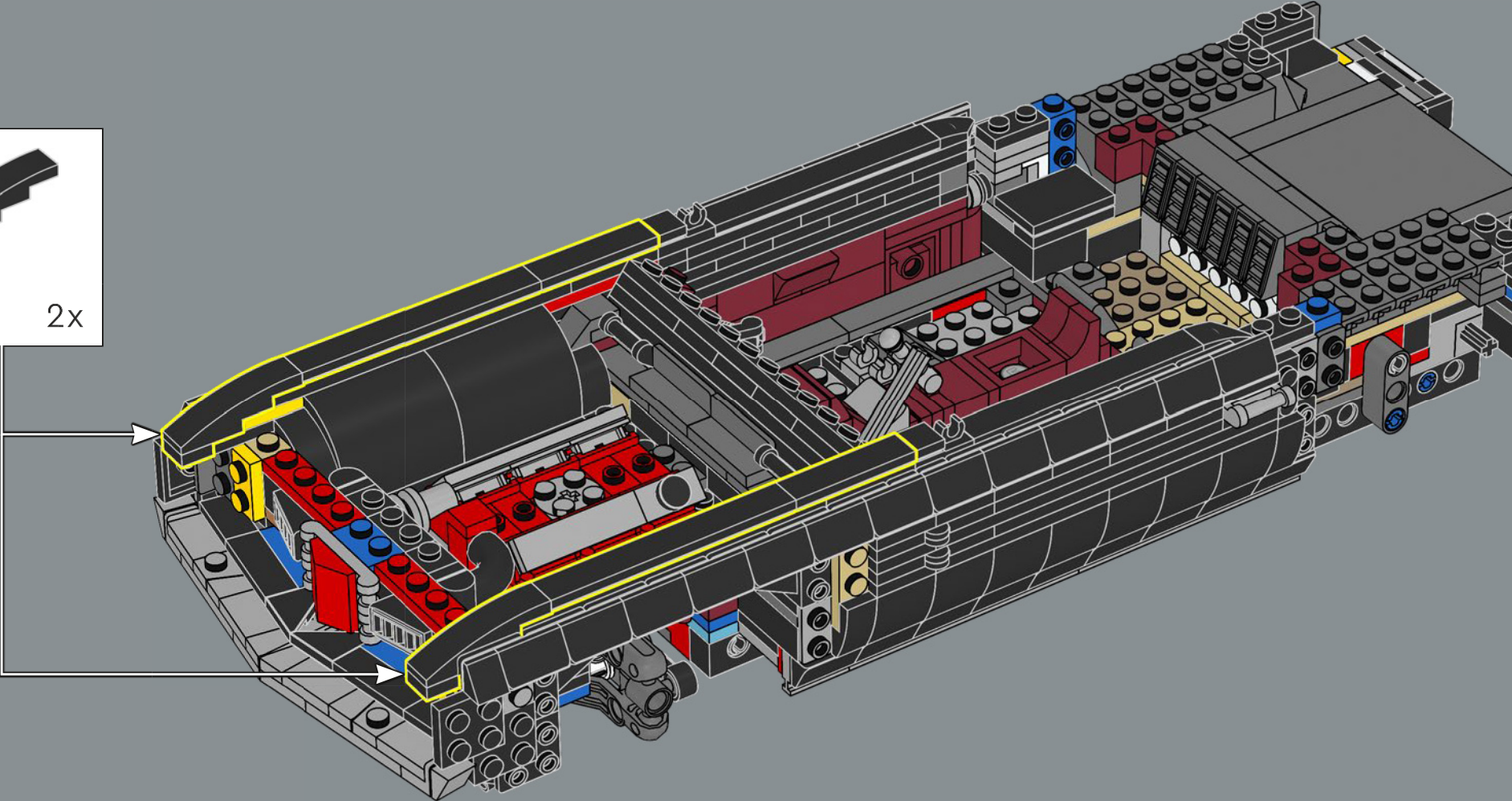
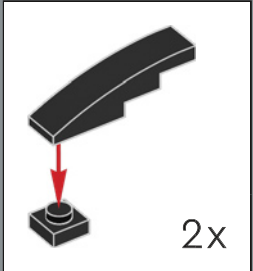

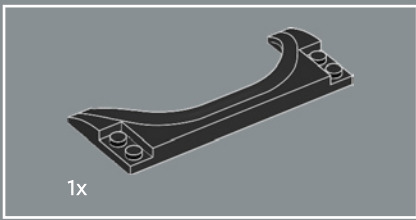

213

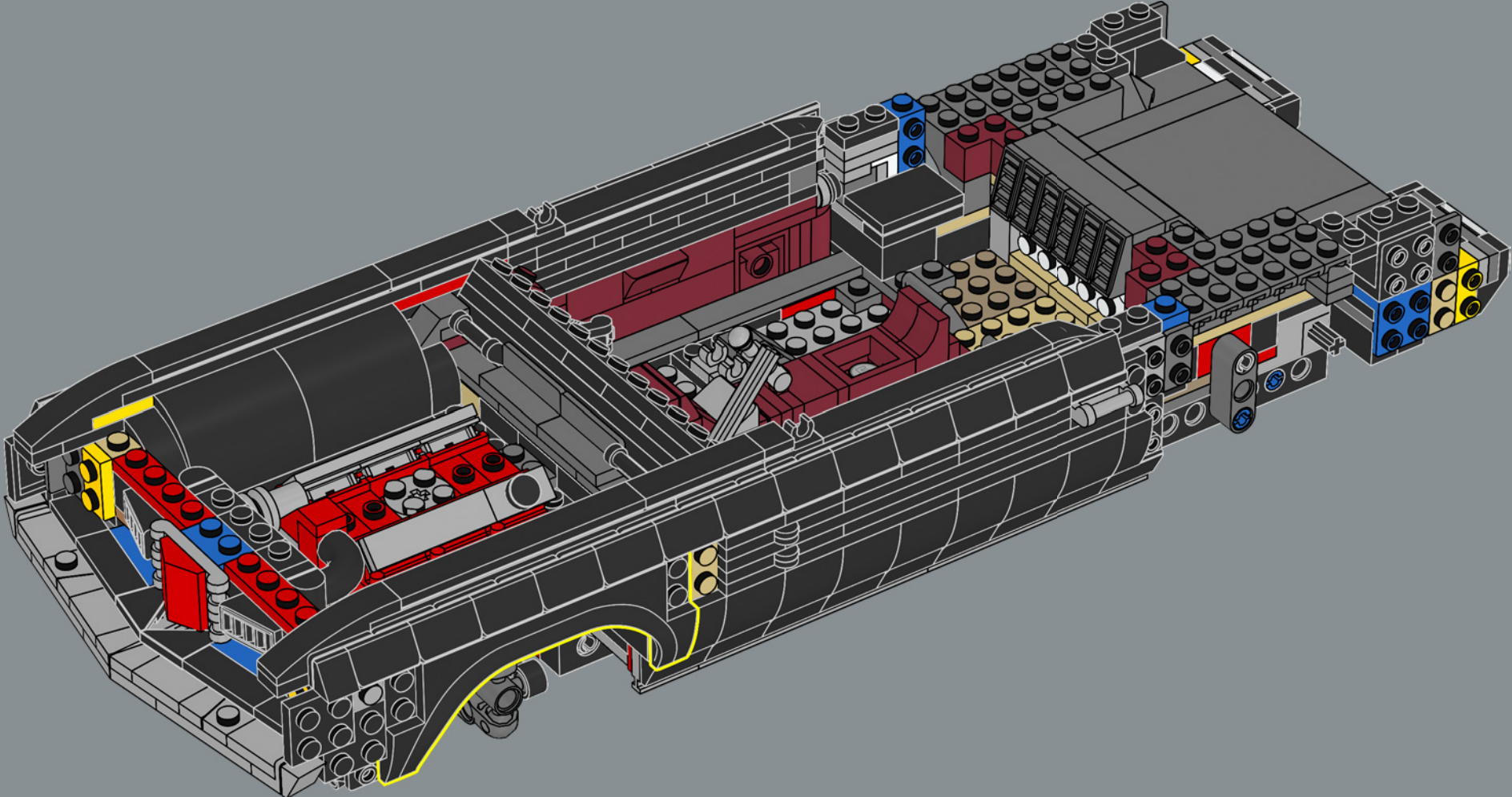

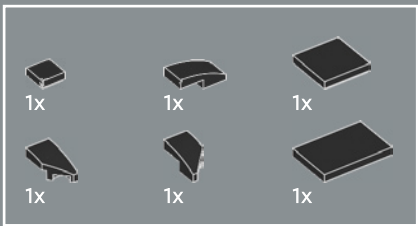

214

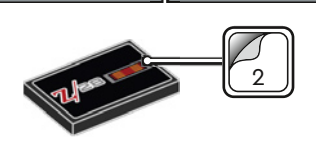
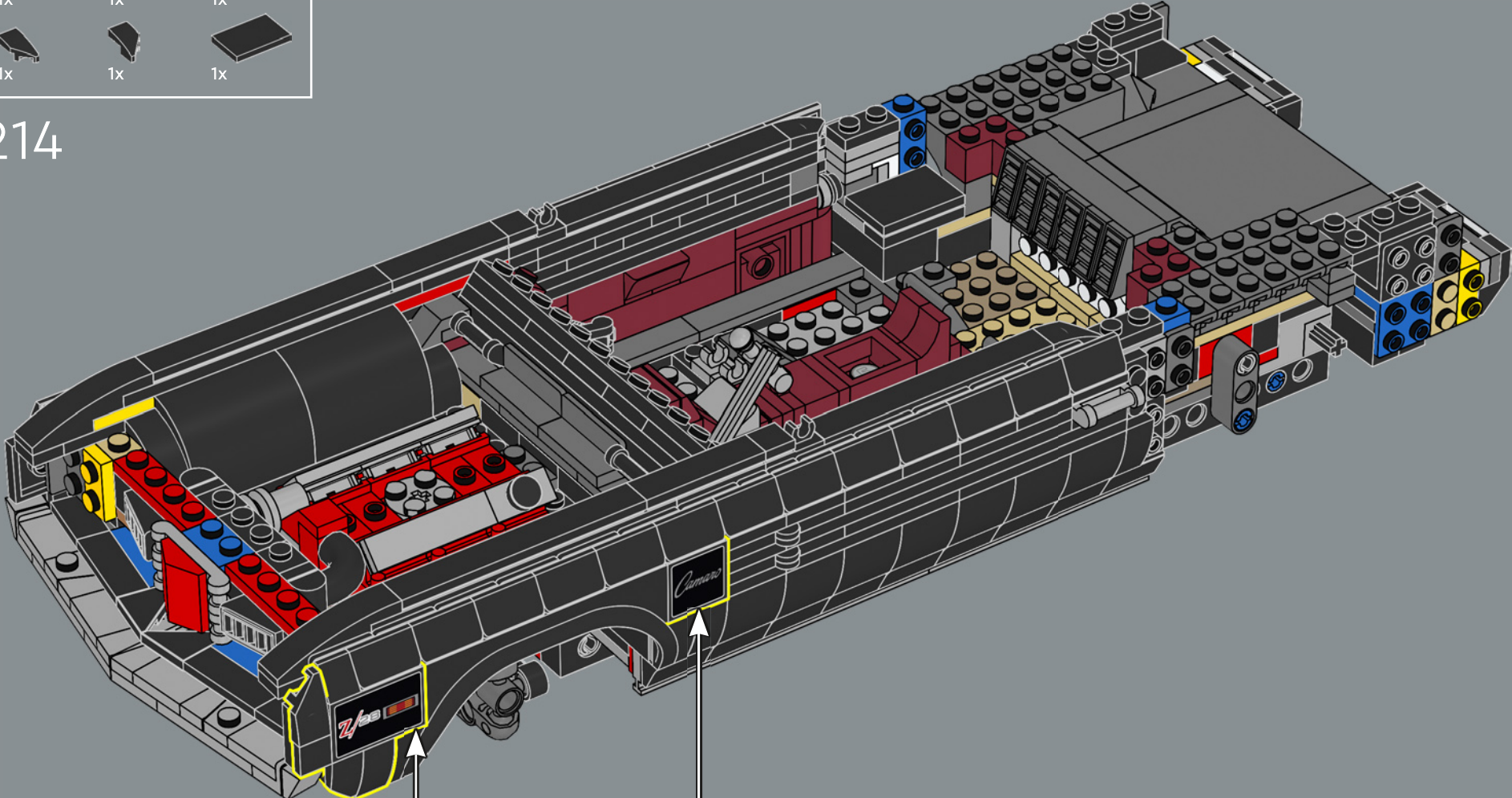

En un principio, Chevrolet consideró también la posibilidad de fabricar una versión familiar del Camaro.

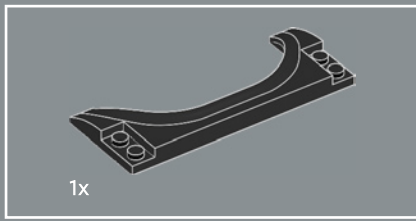

215

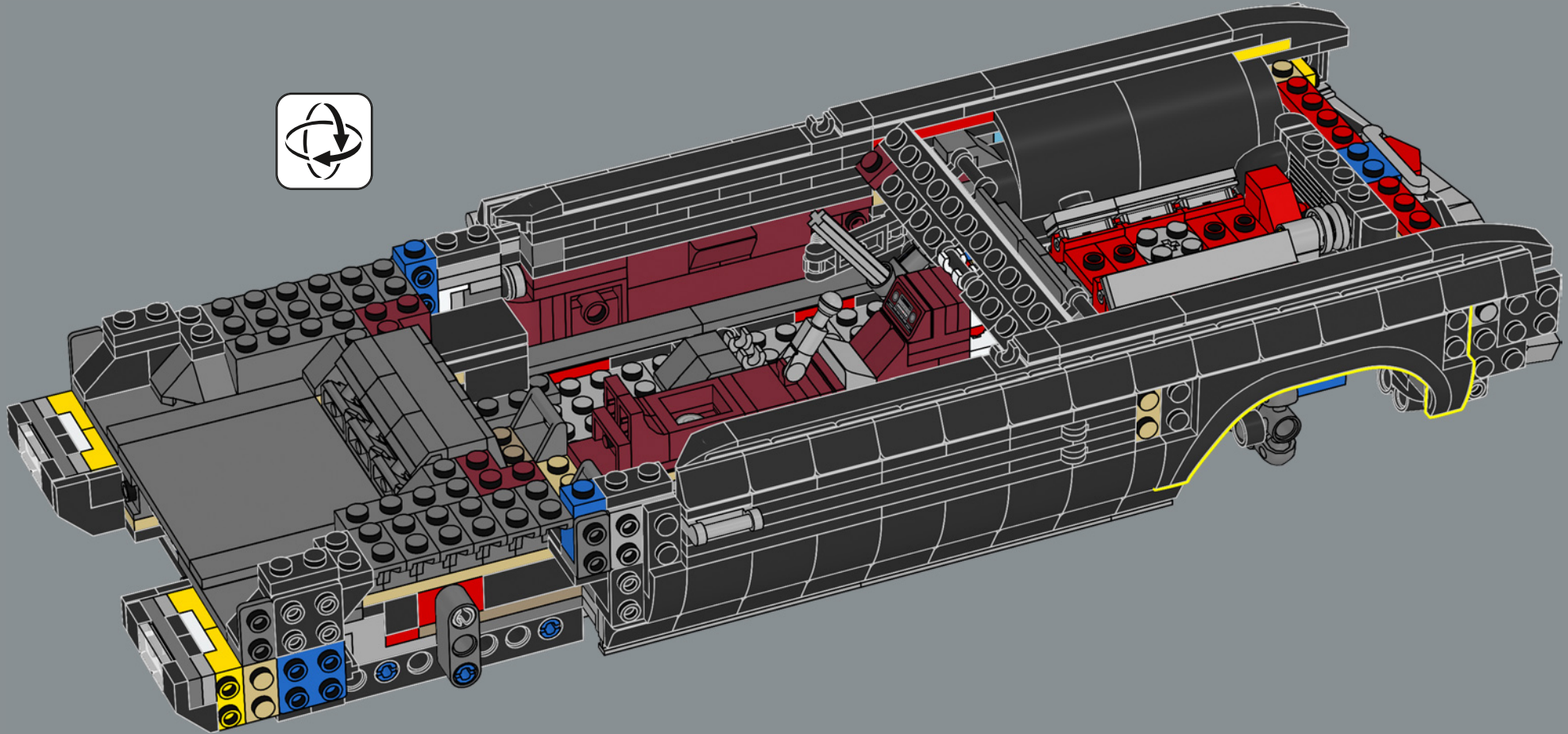

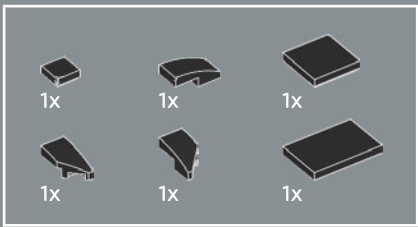

216

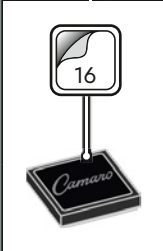
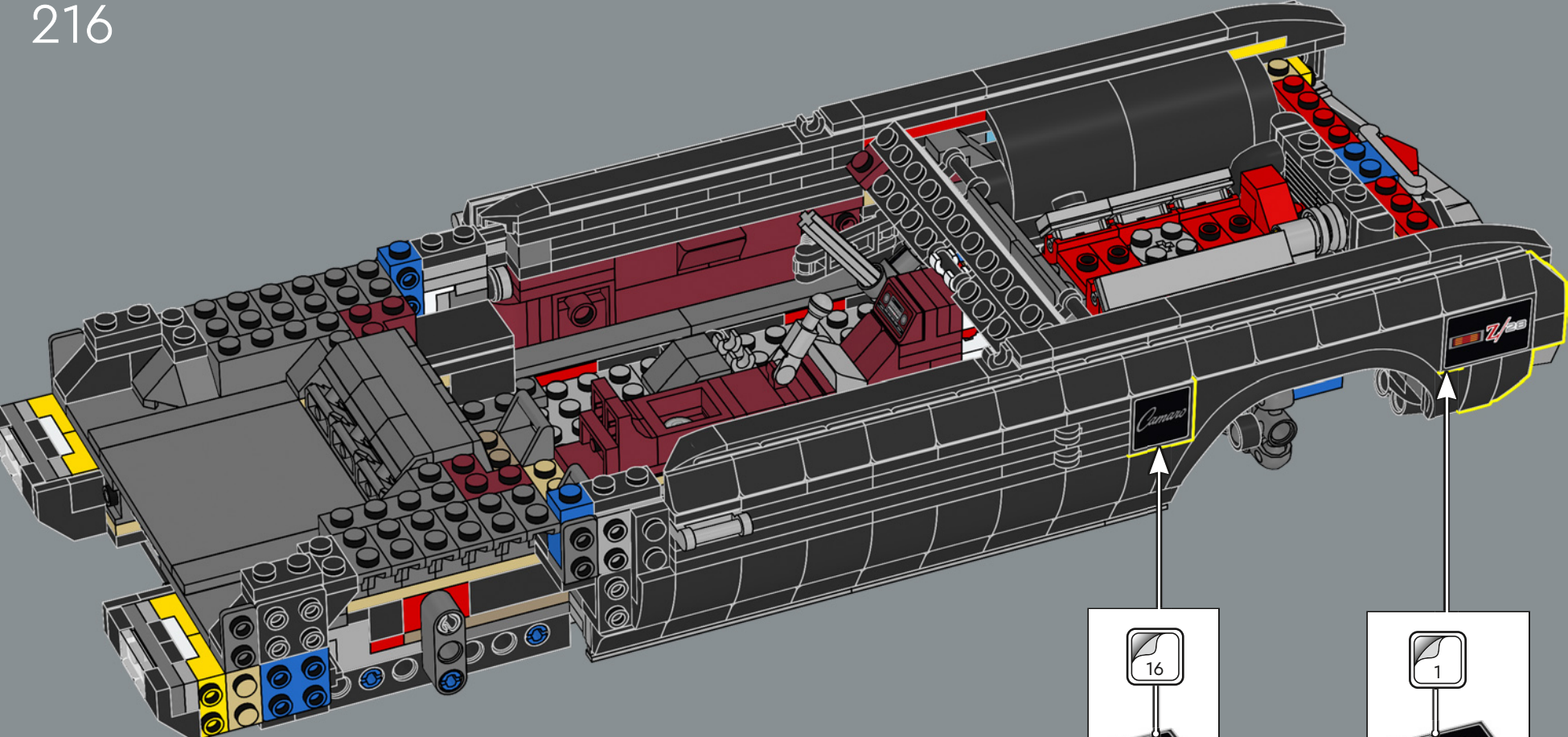

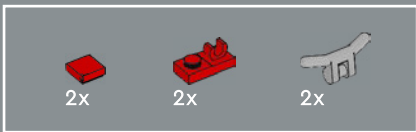

217

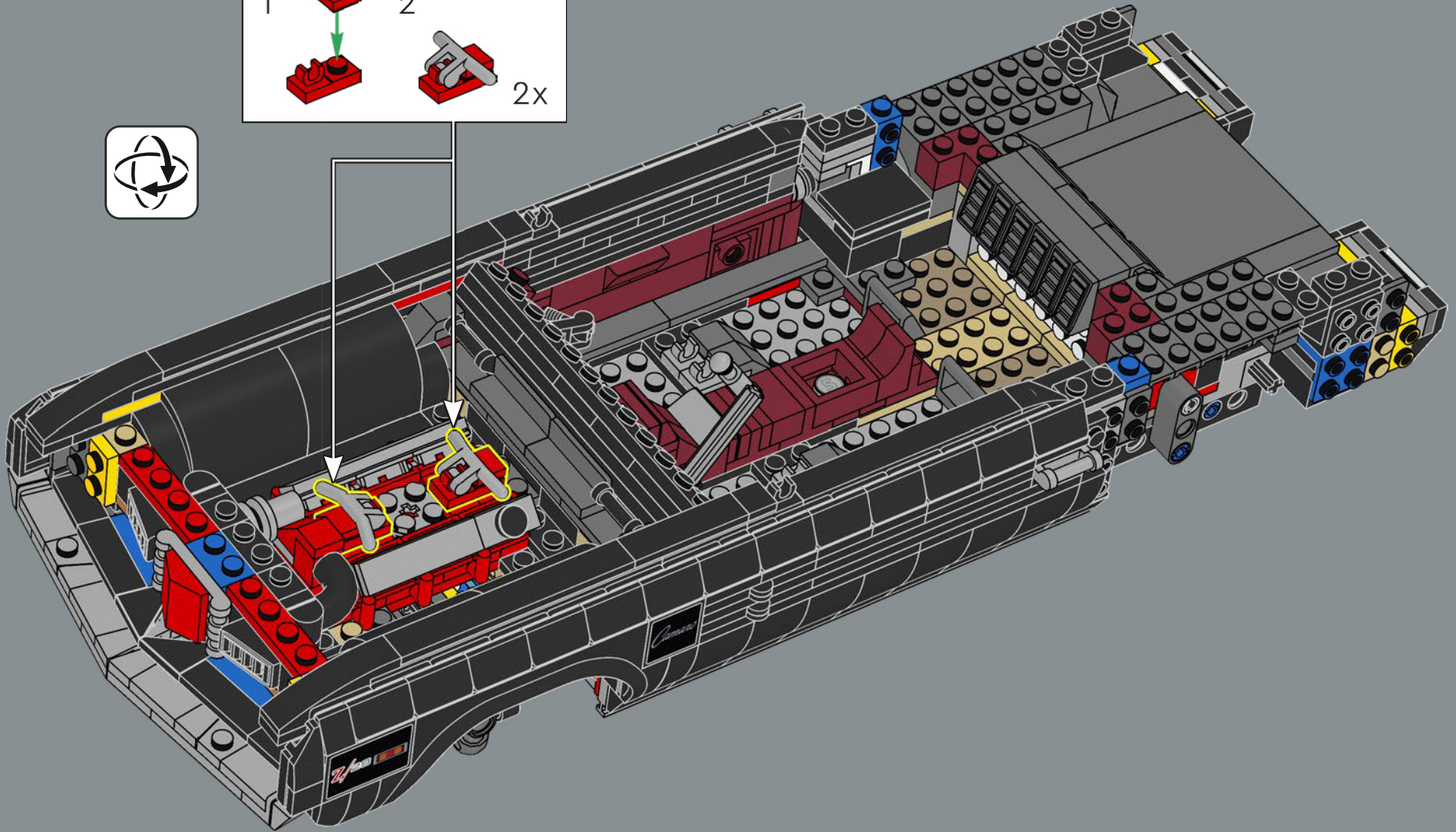
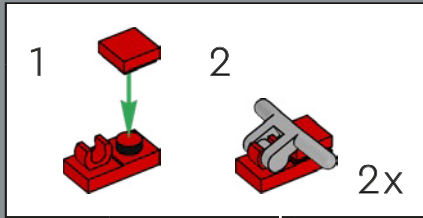

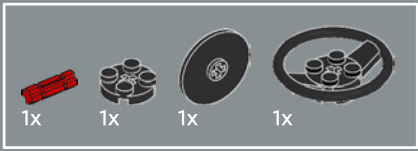

218

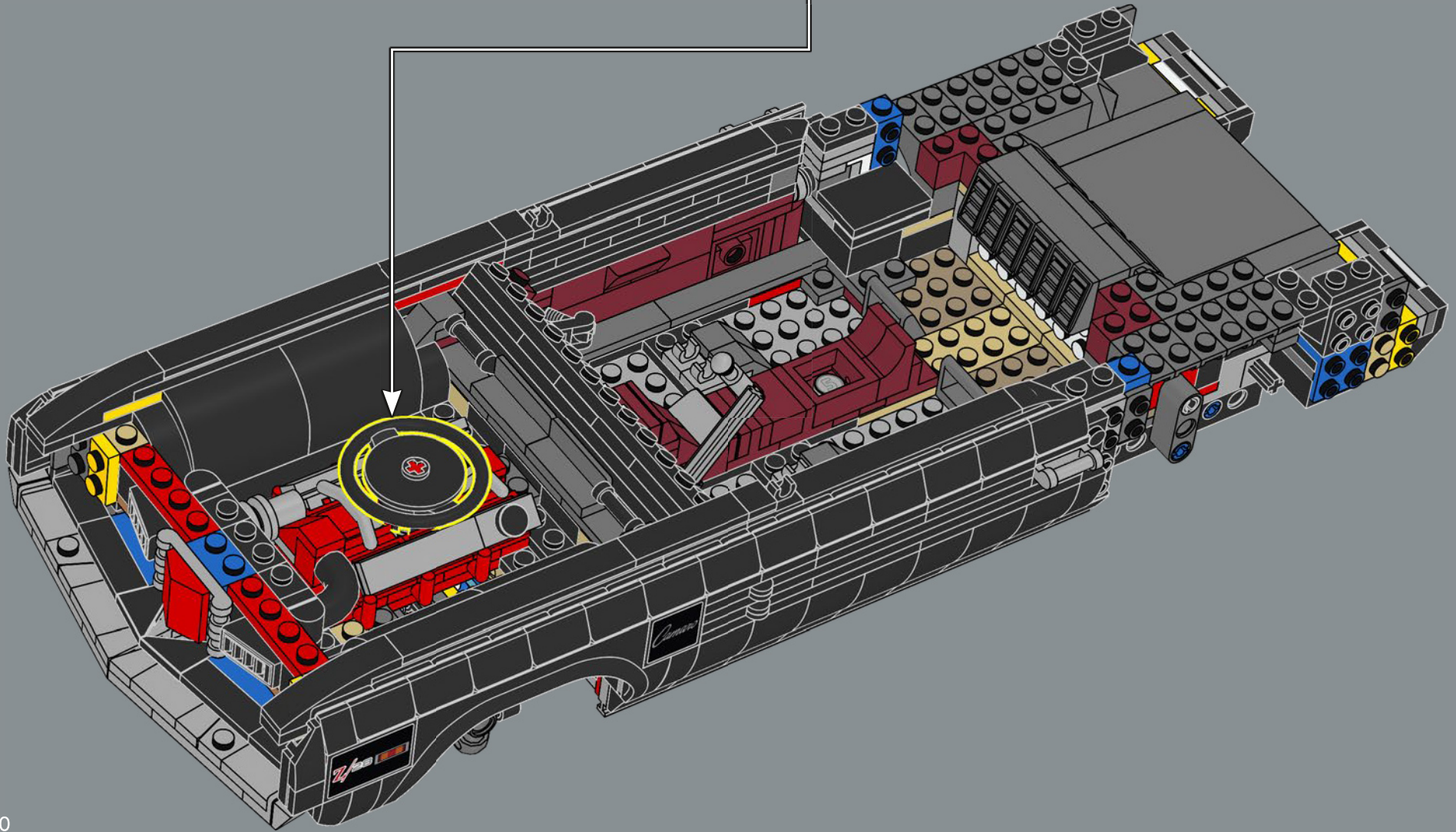
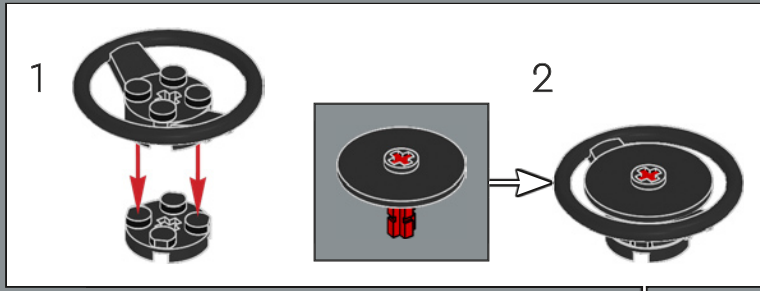

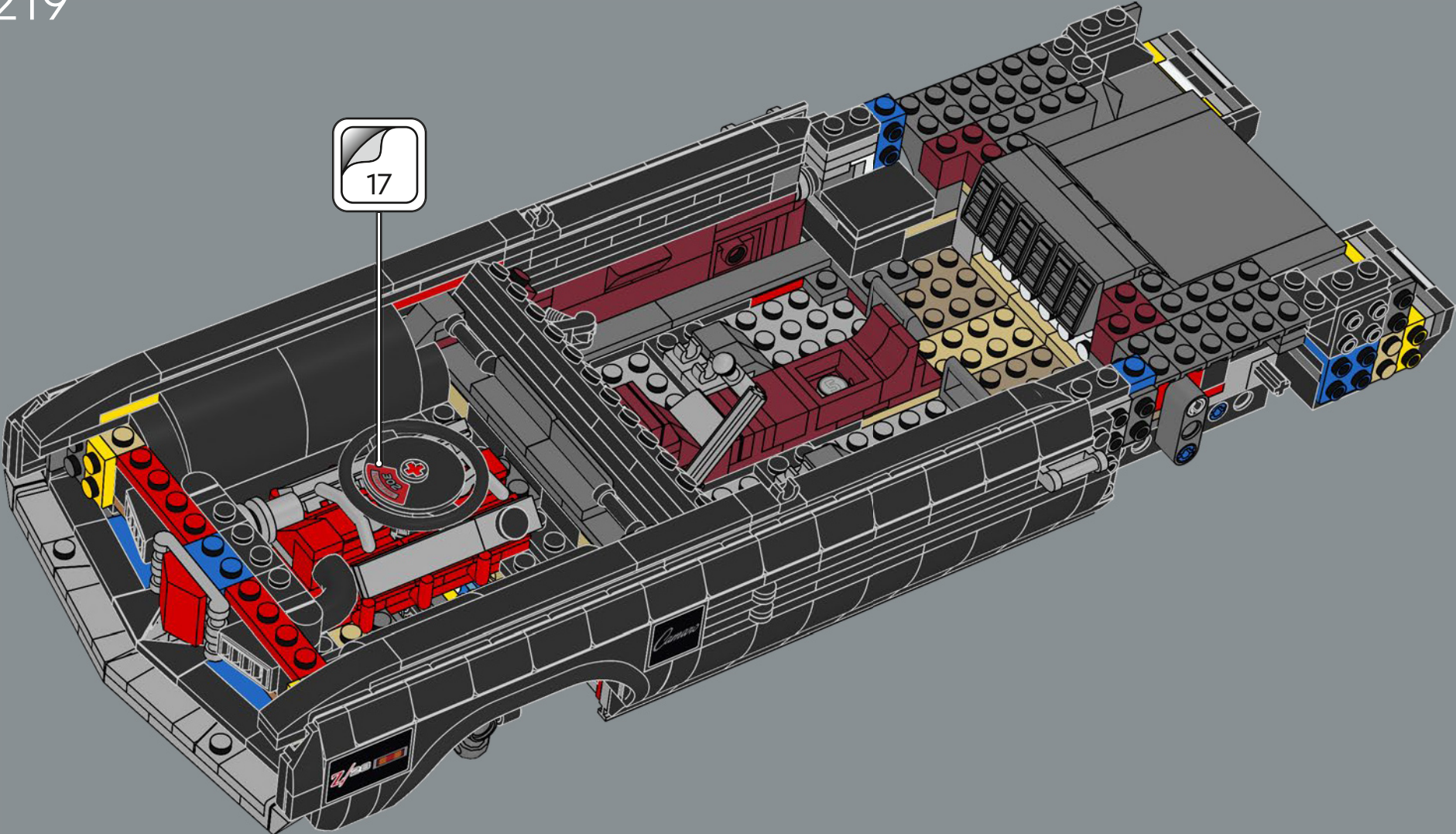

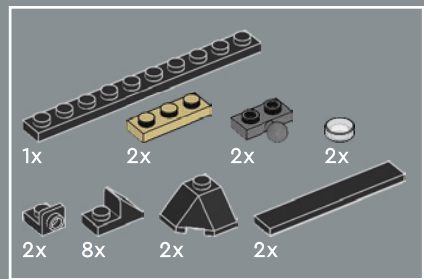

220

1

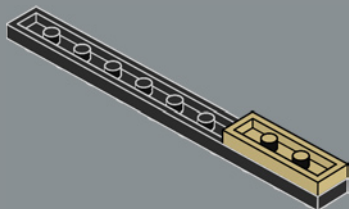

2

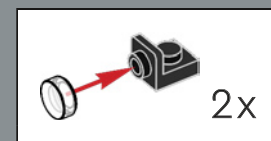
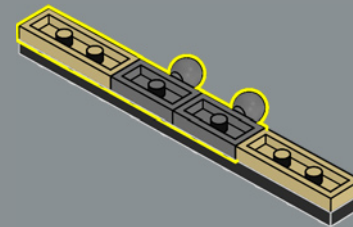

3

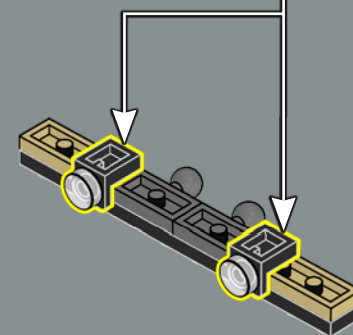

4

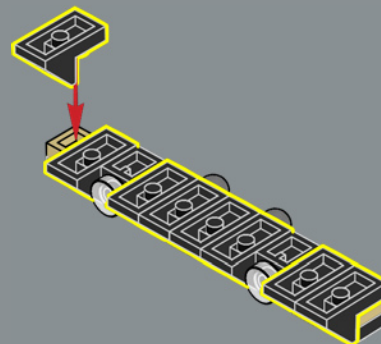

5

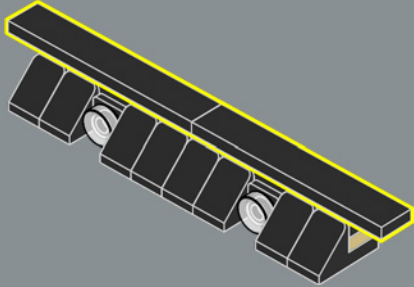

6

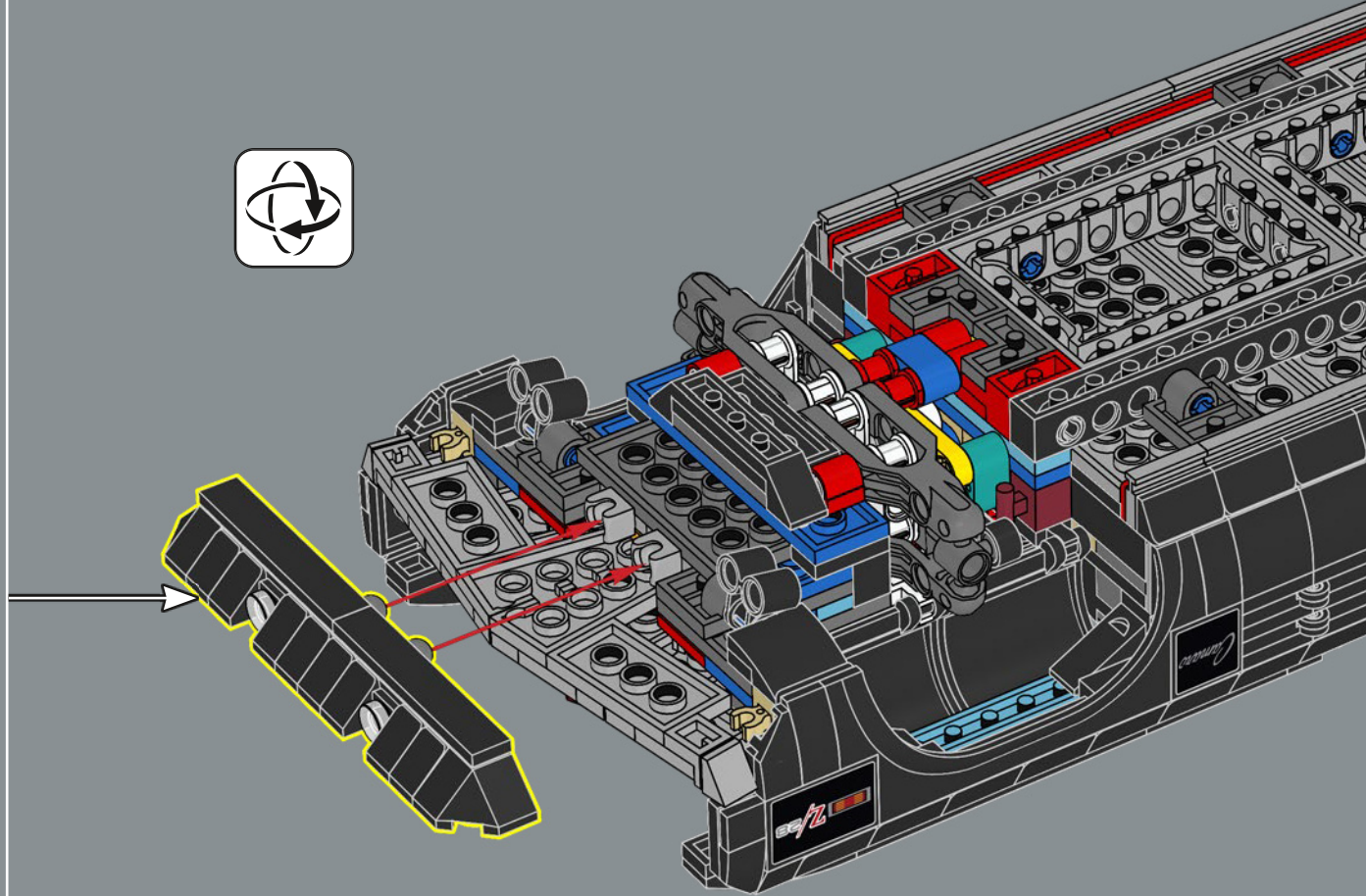
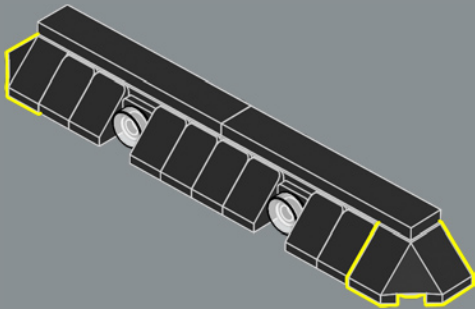

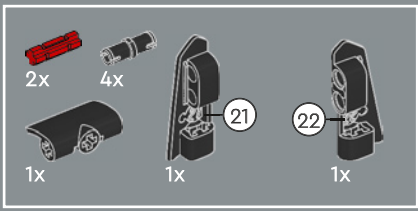

221

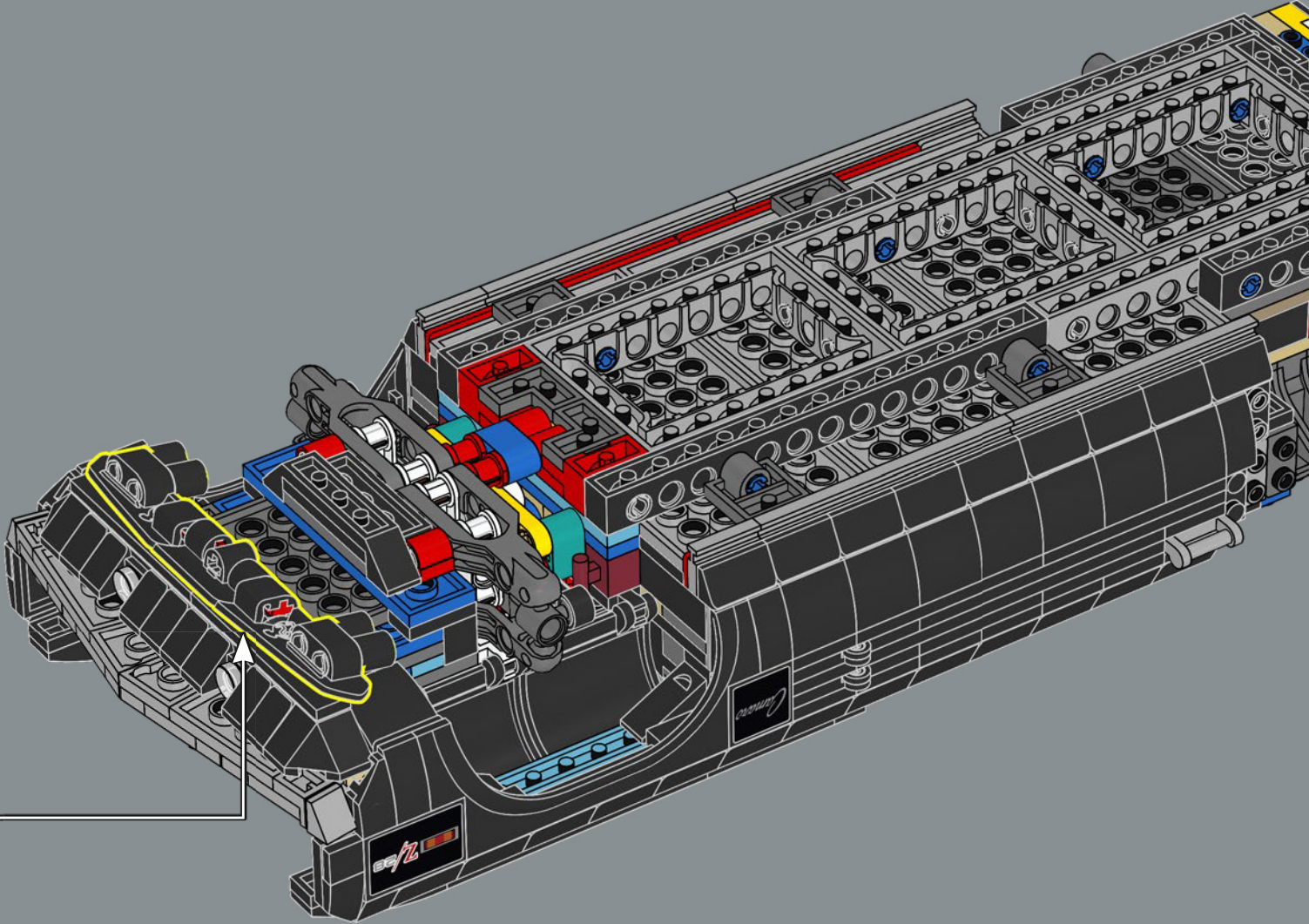
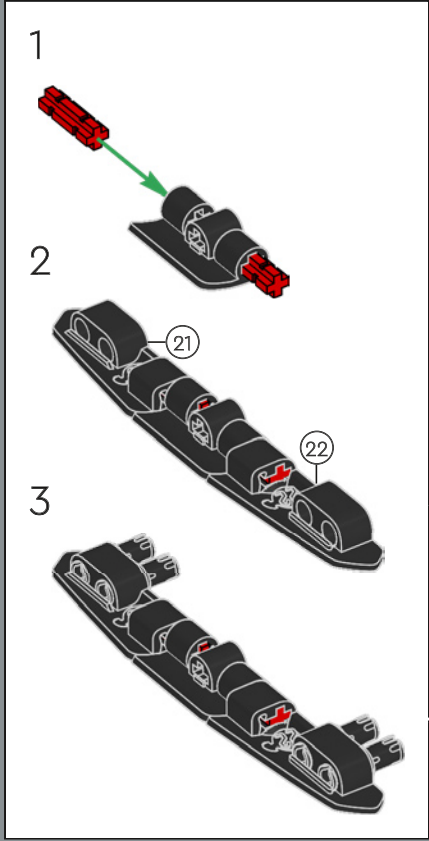



222

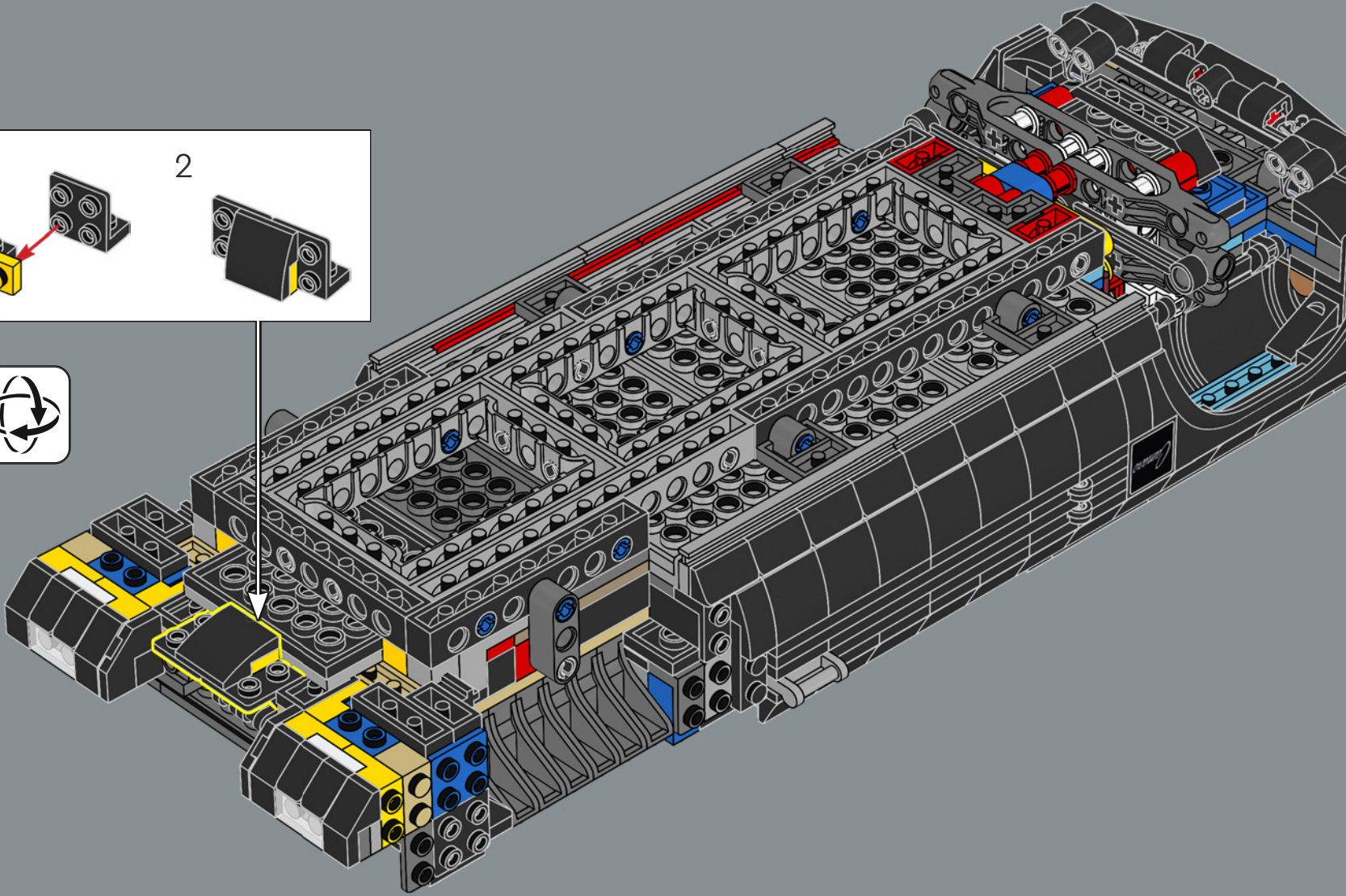
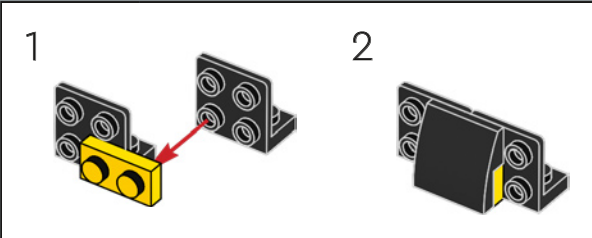

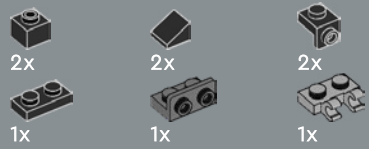

223

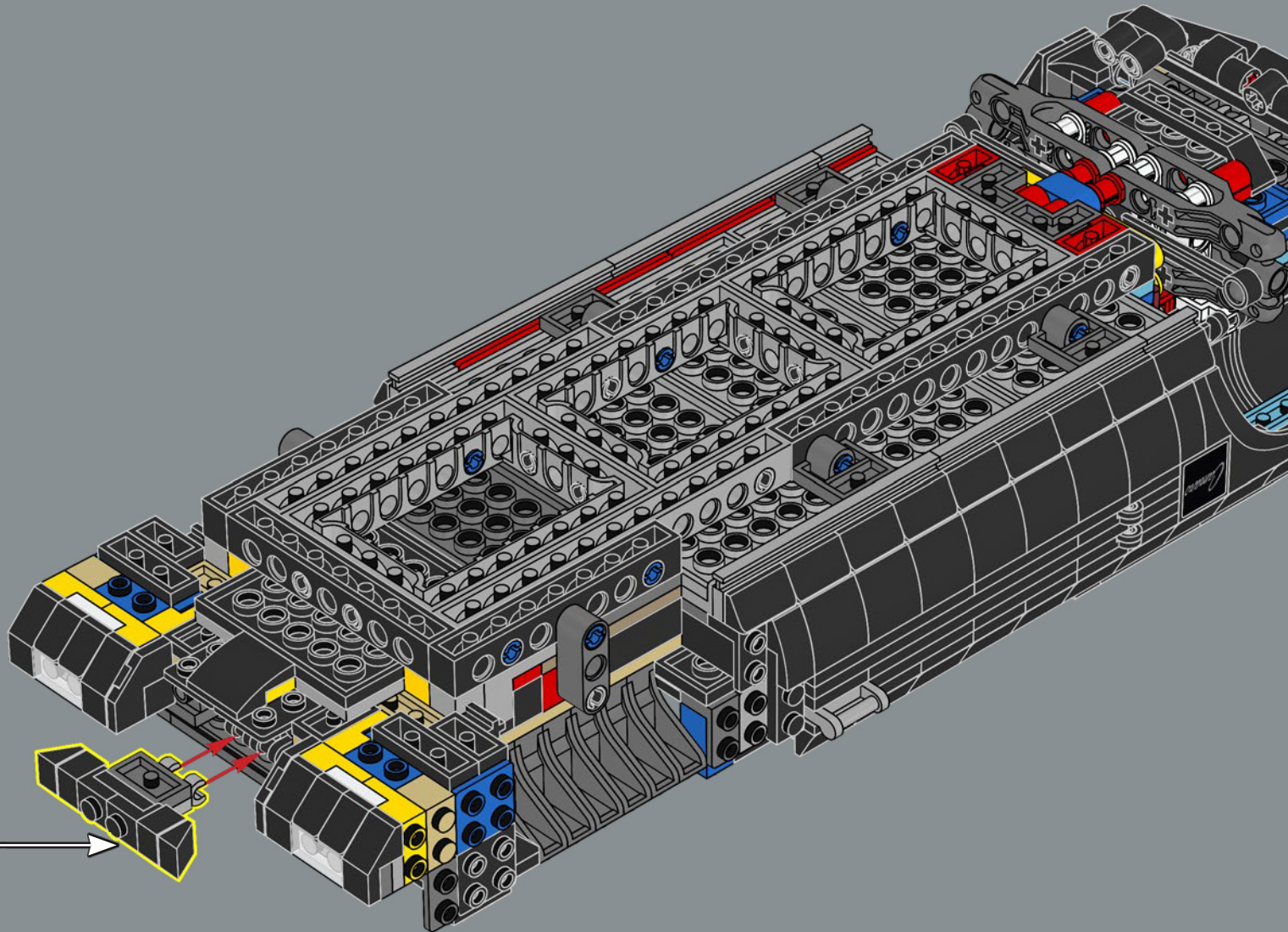
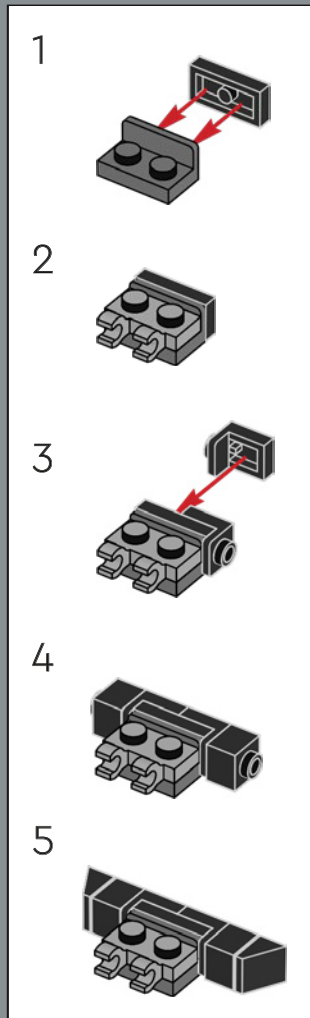

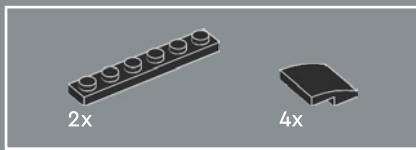

224

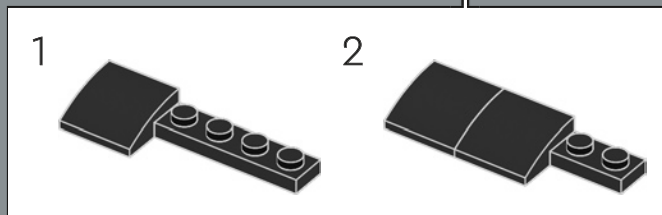
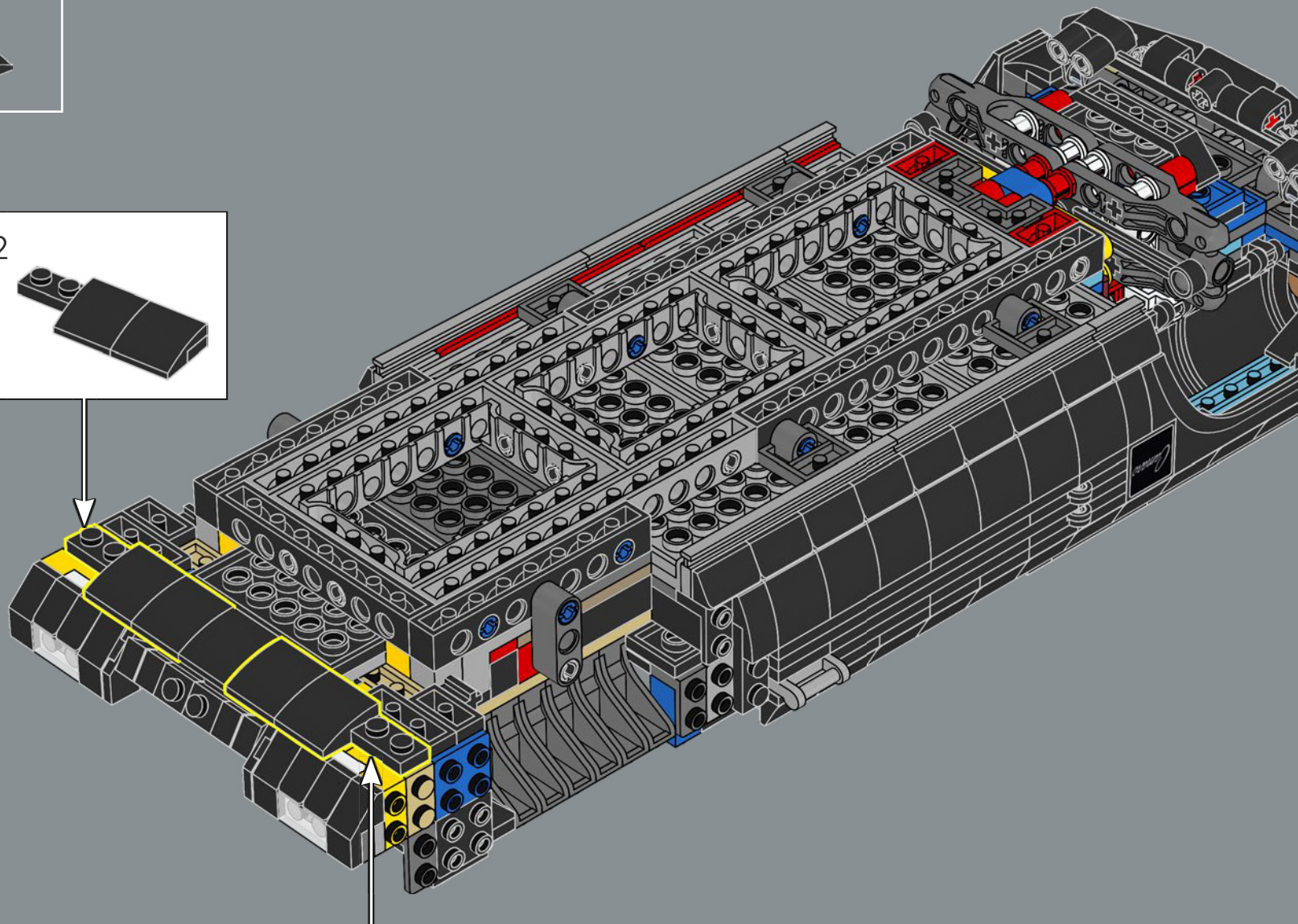
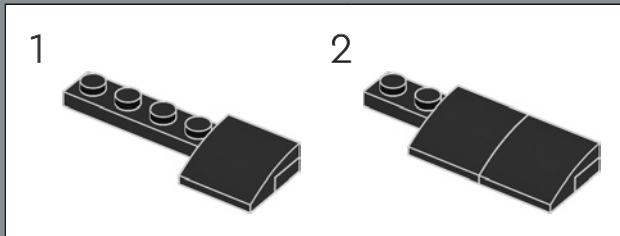



225

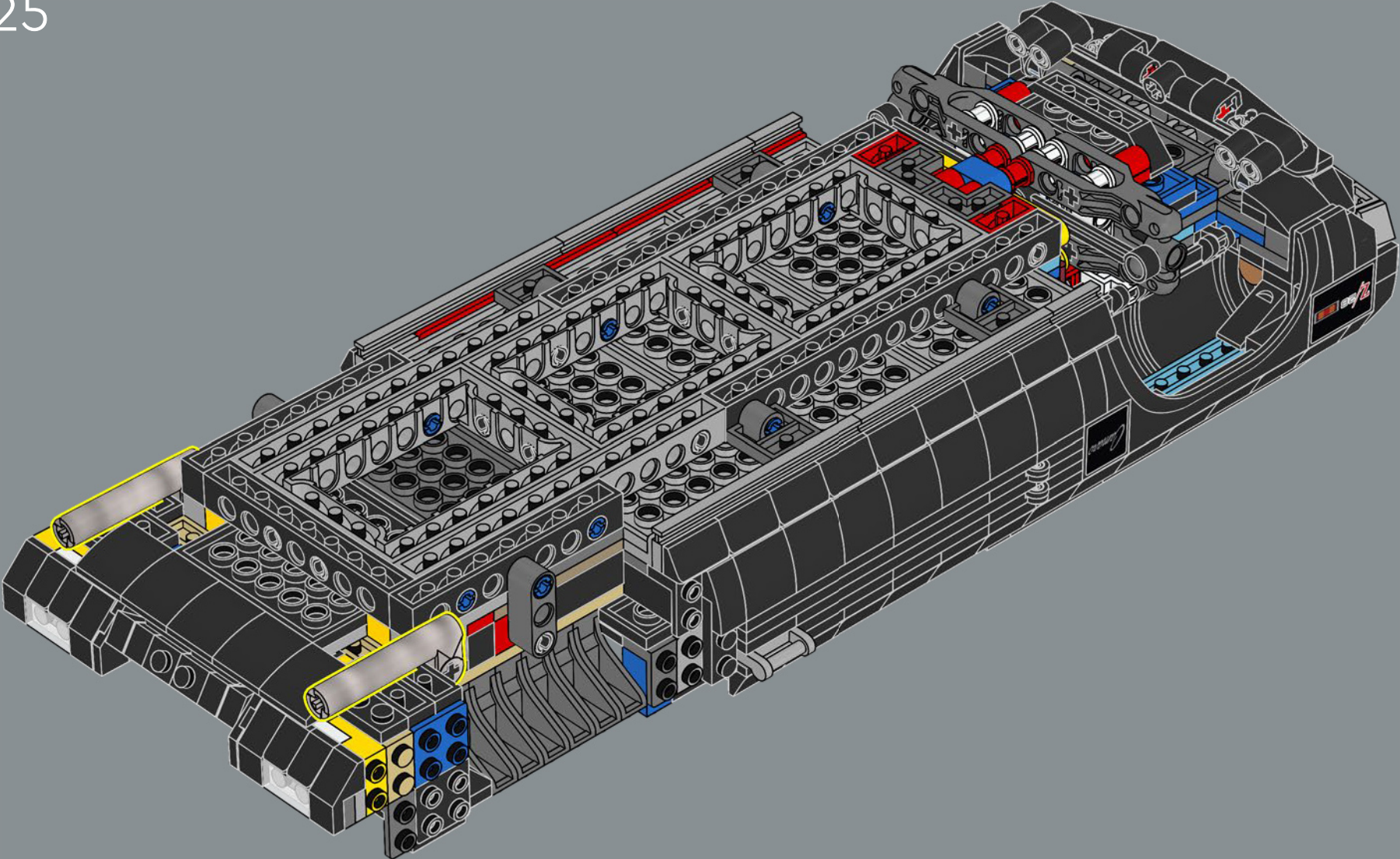

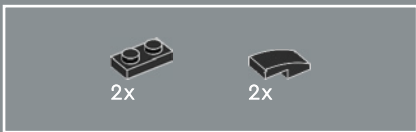

226

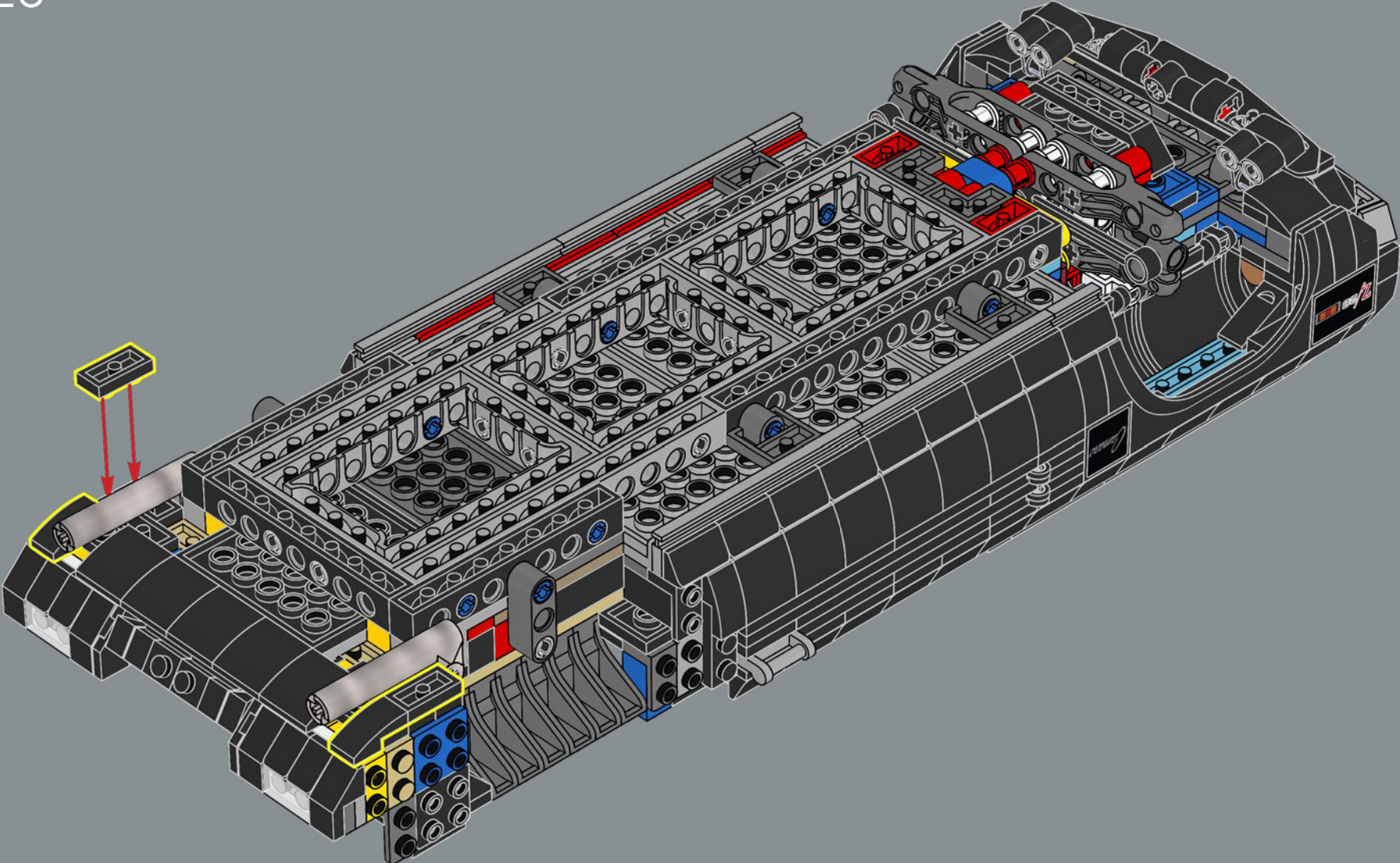

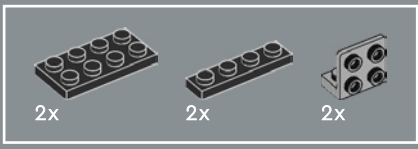

227

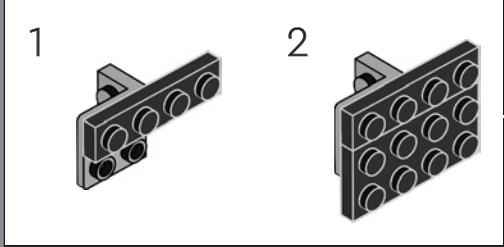
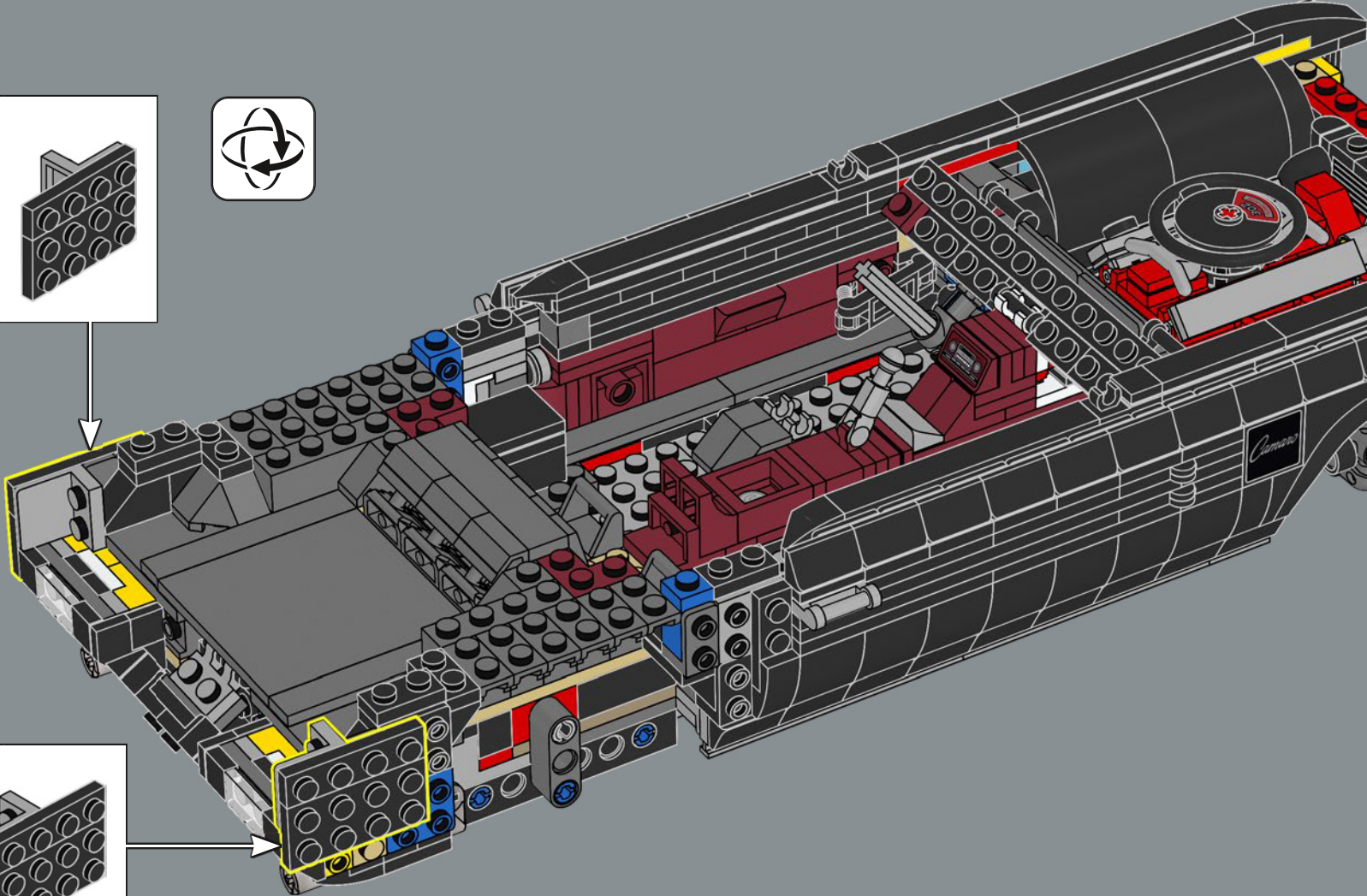
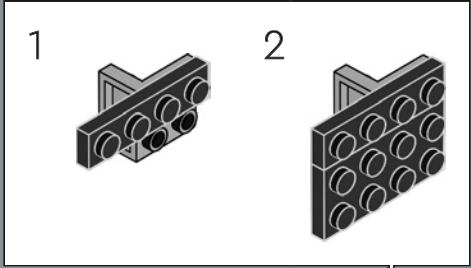

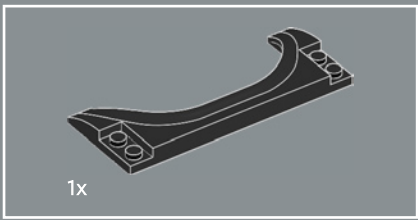

228

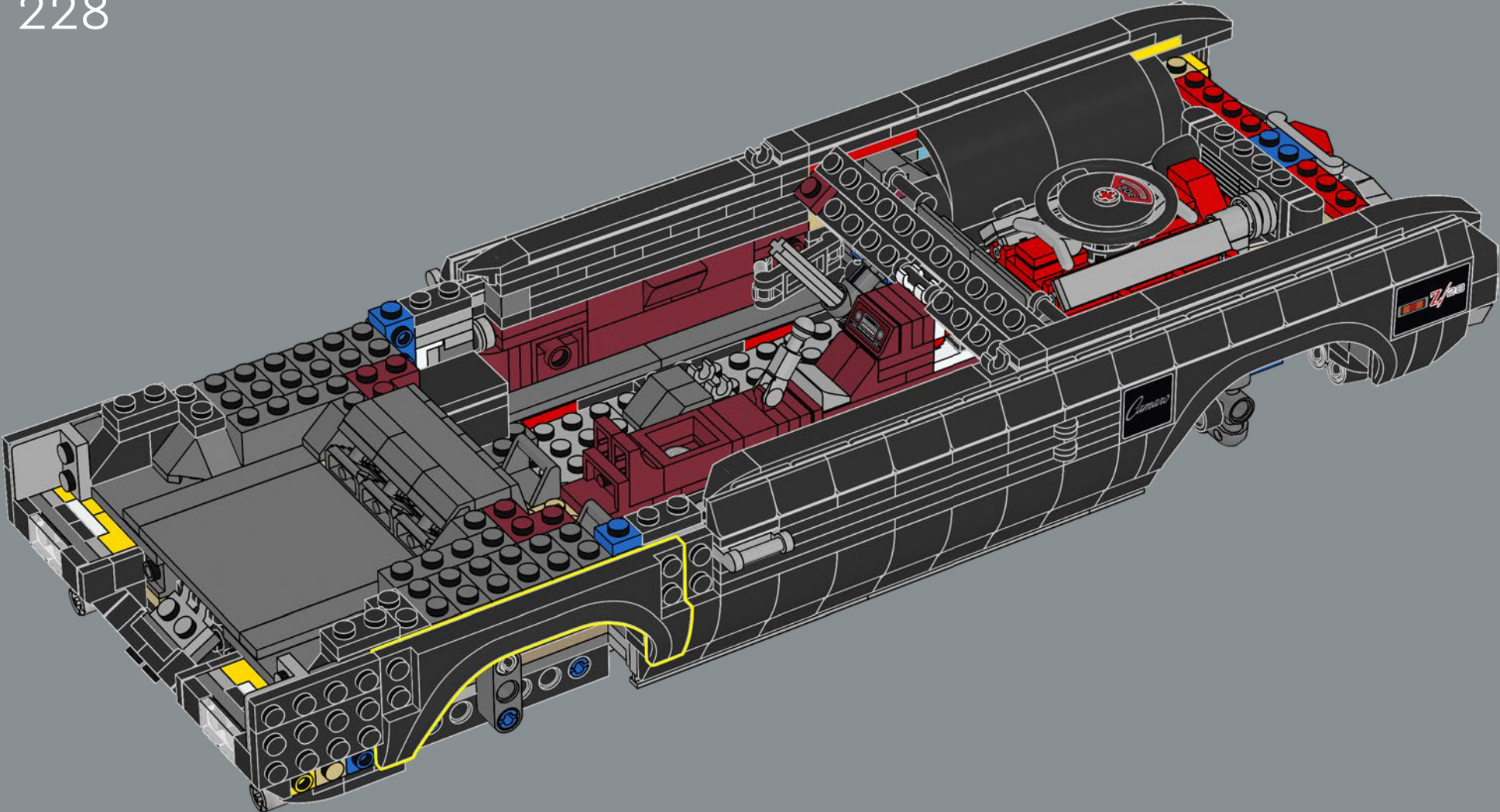

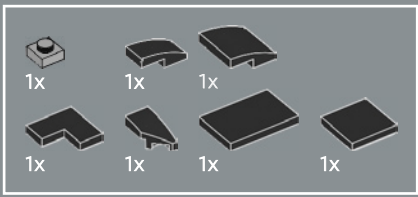

229

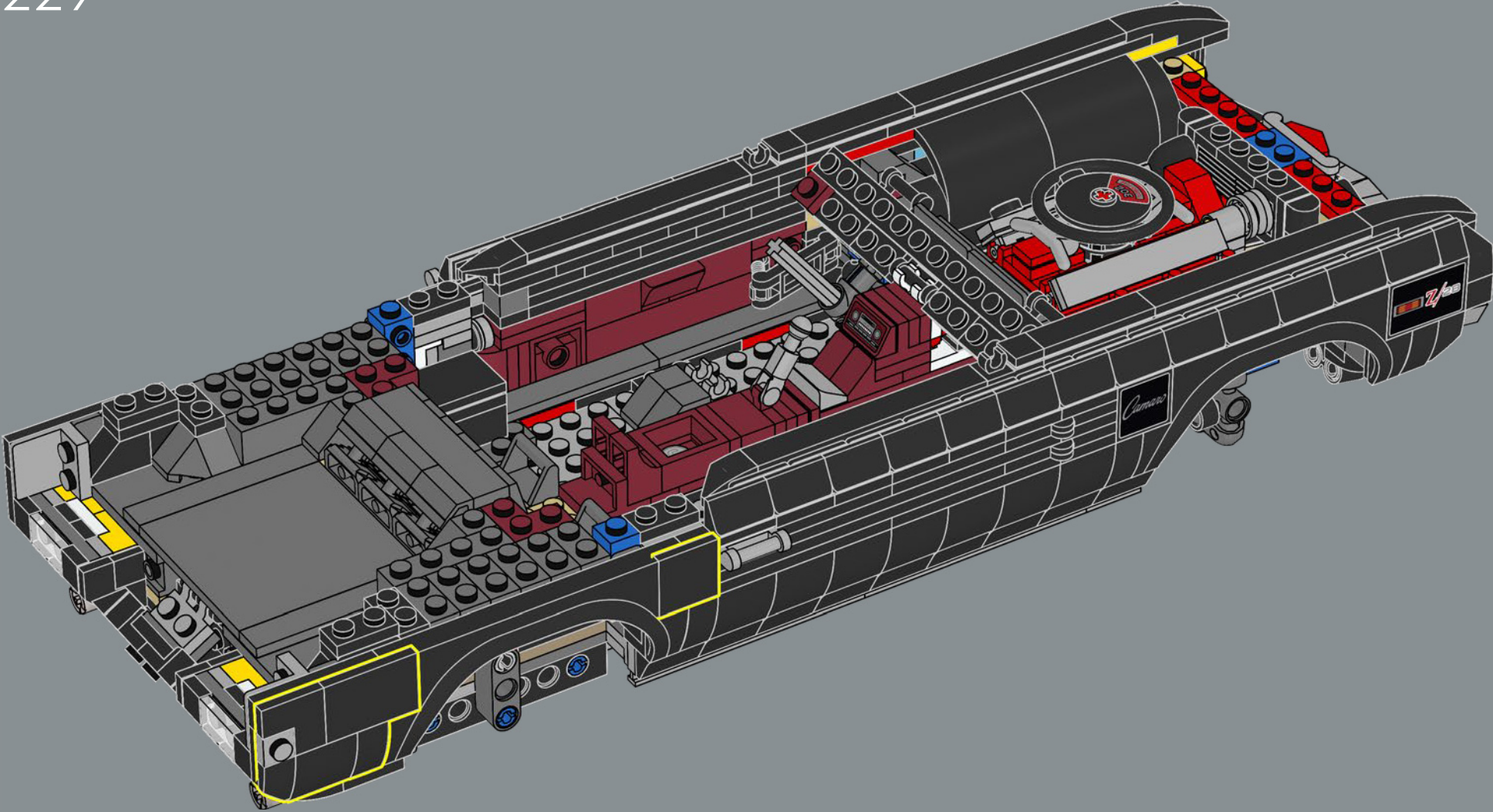

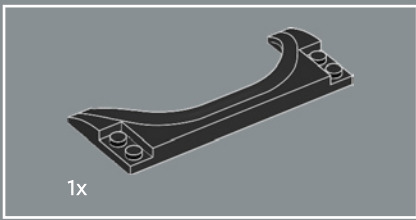

230

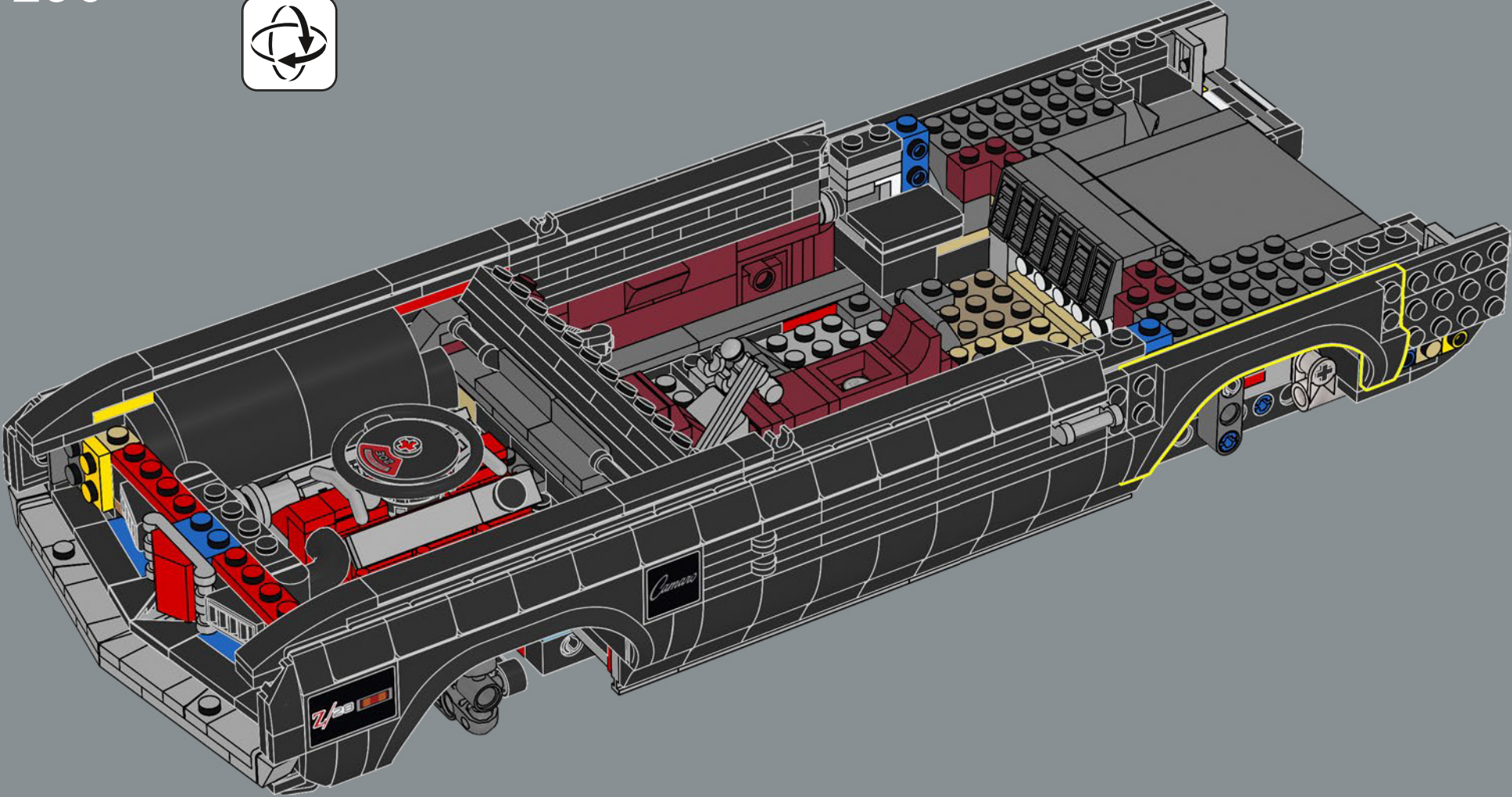

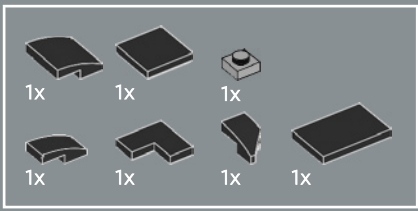

231

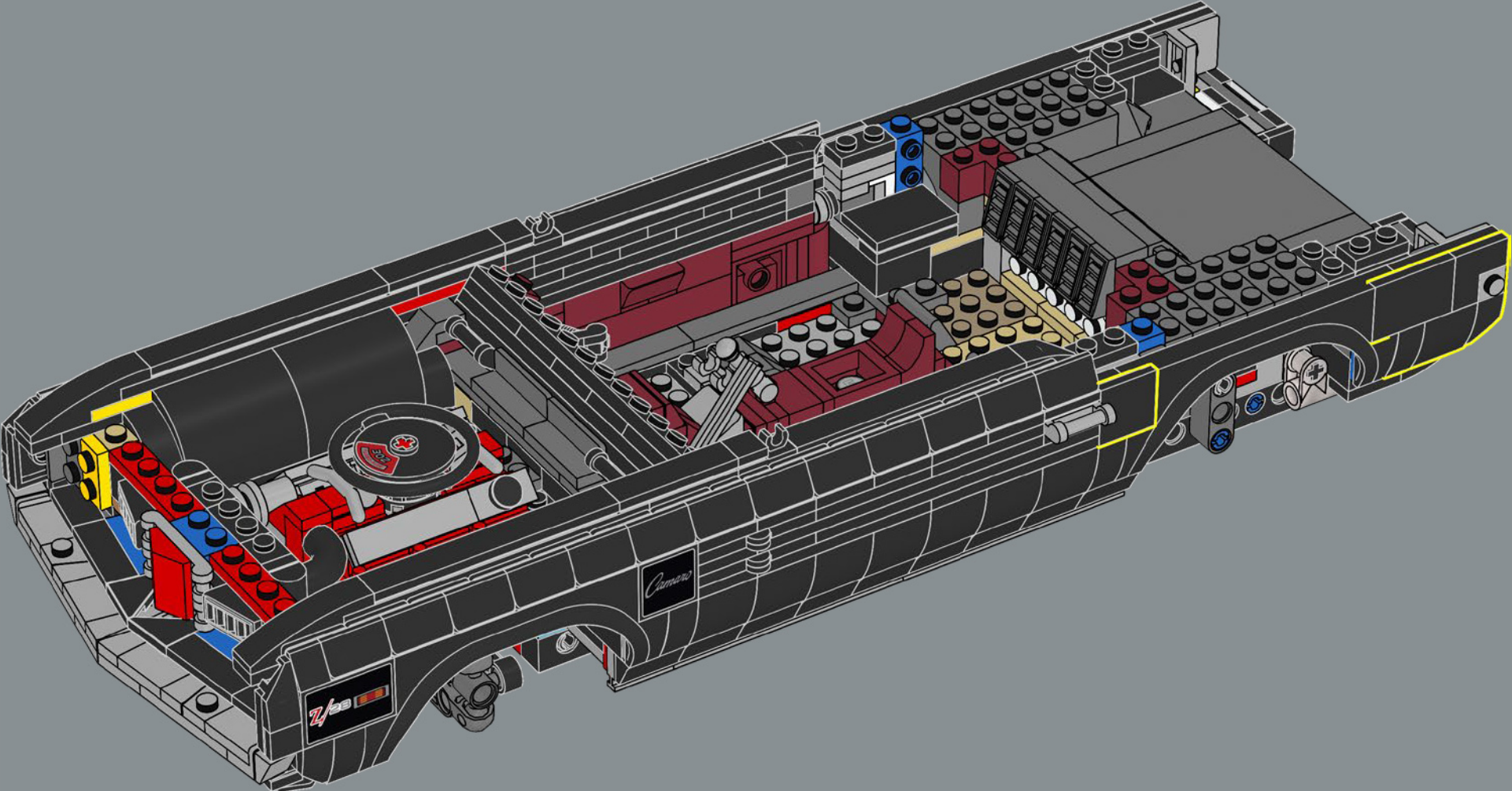

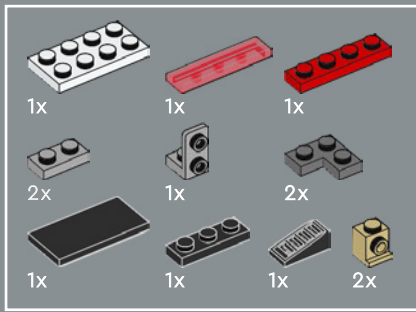

232

1



2



3

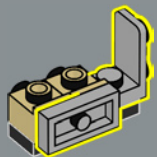

4

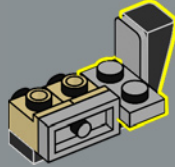

5

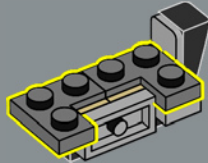

6

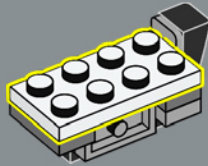

7

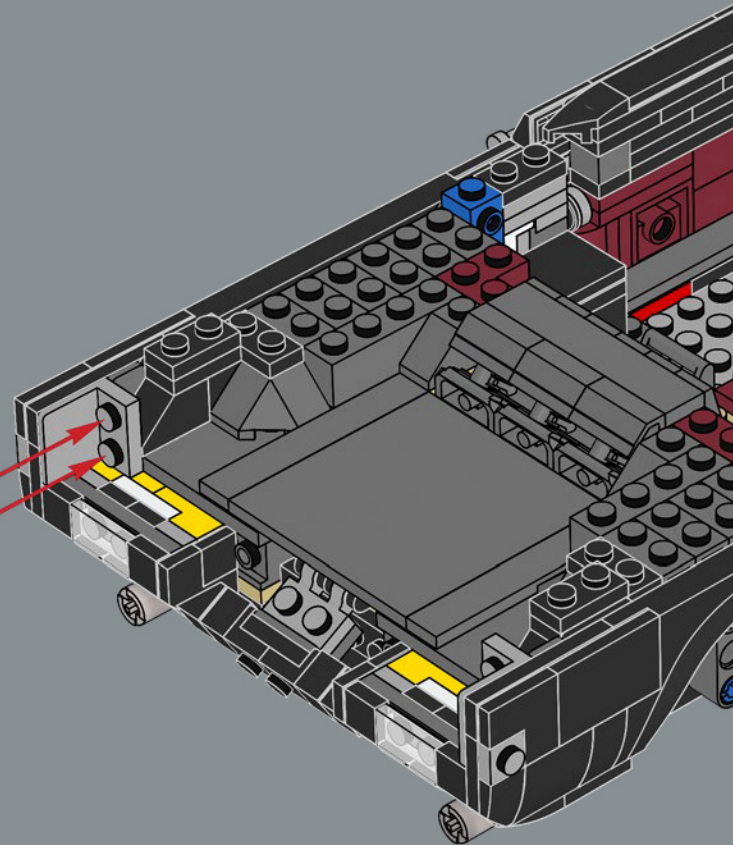
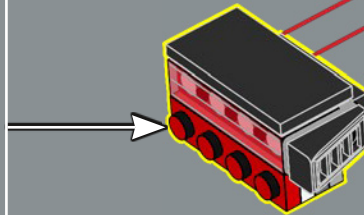
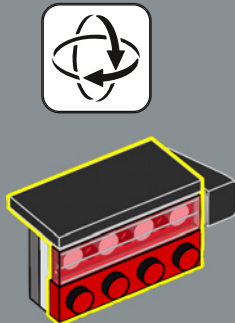

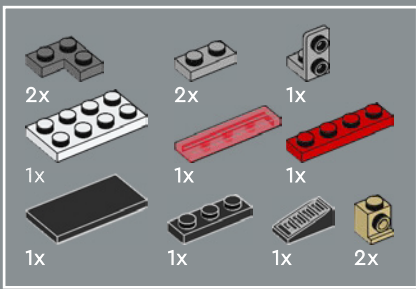

233

1



2



3

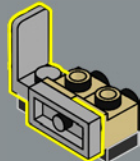

4

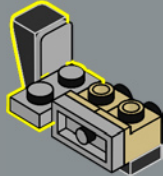

5

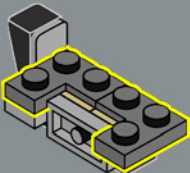

6

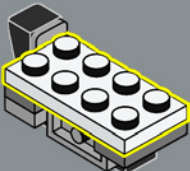

7

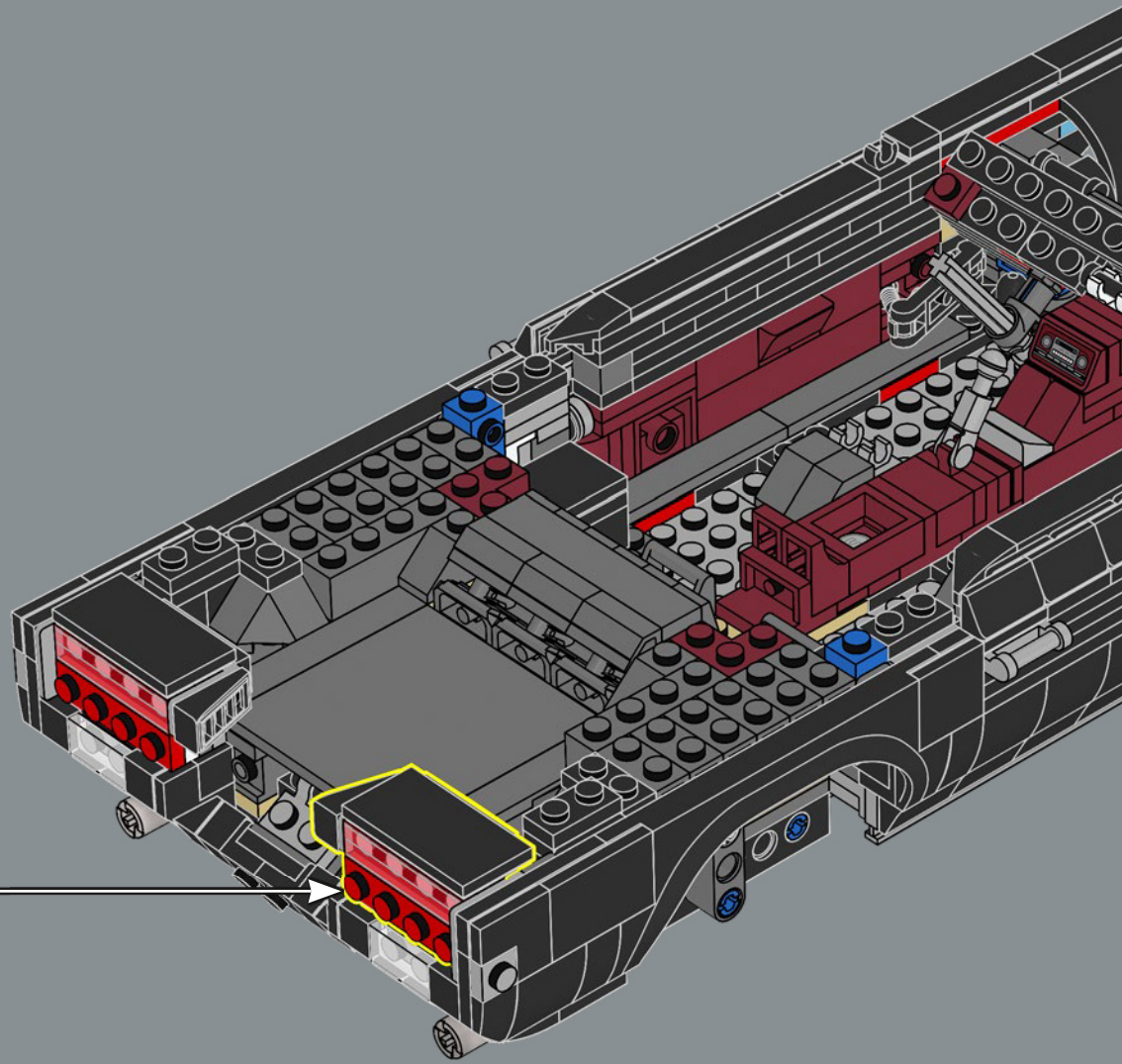
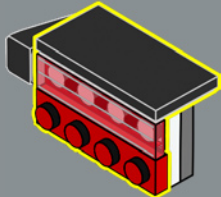

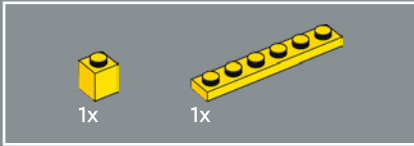
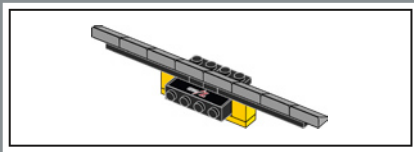

234

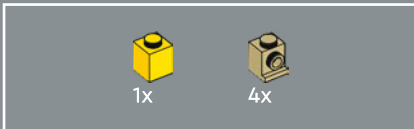
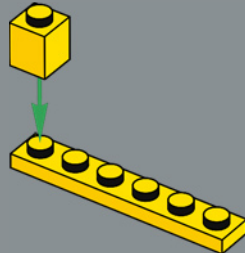

235

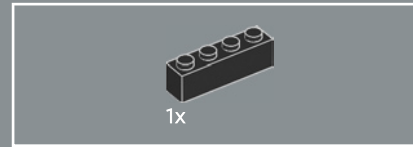
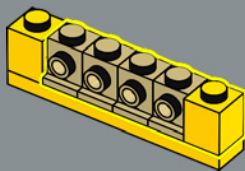

236

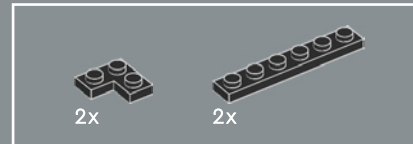
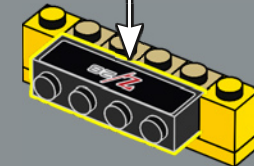
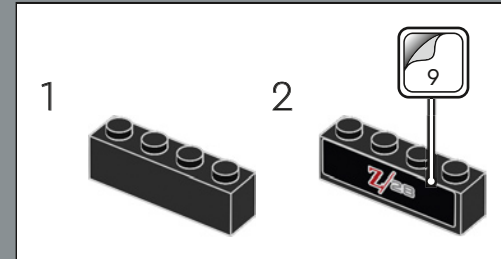

237

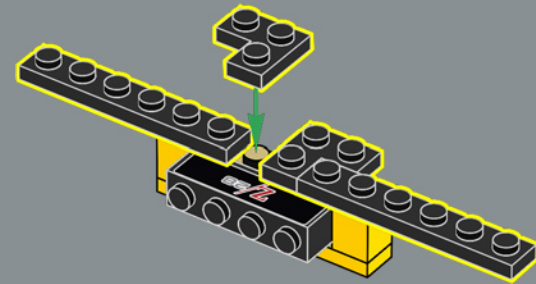



2x

238

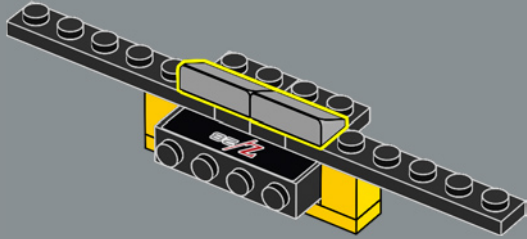

6x

239

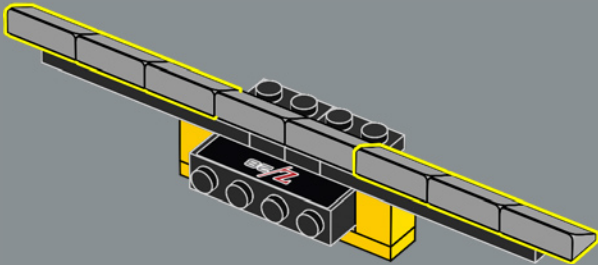

240

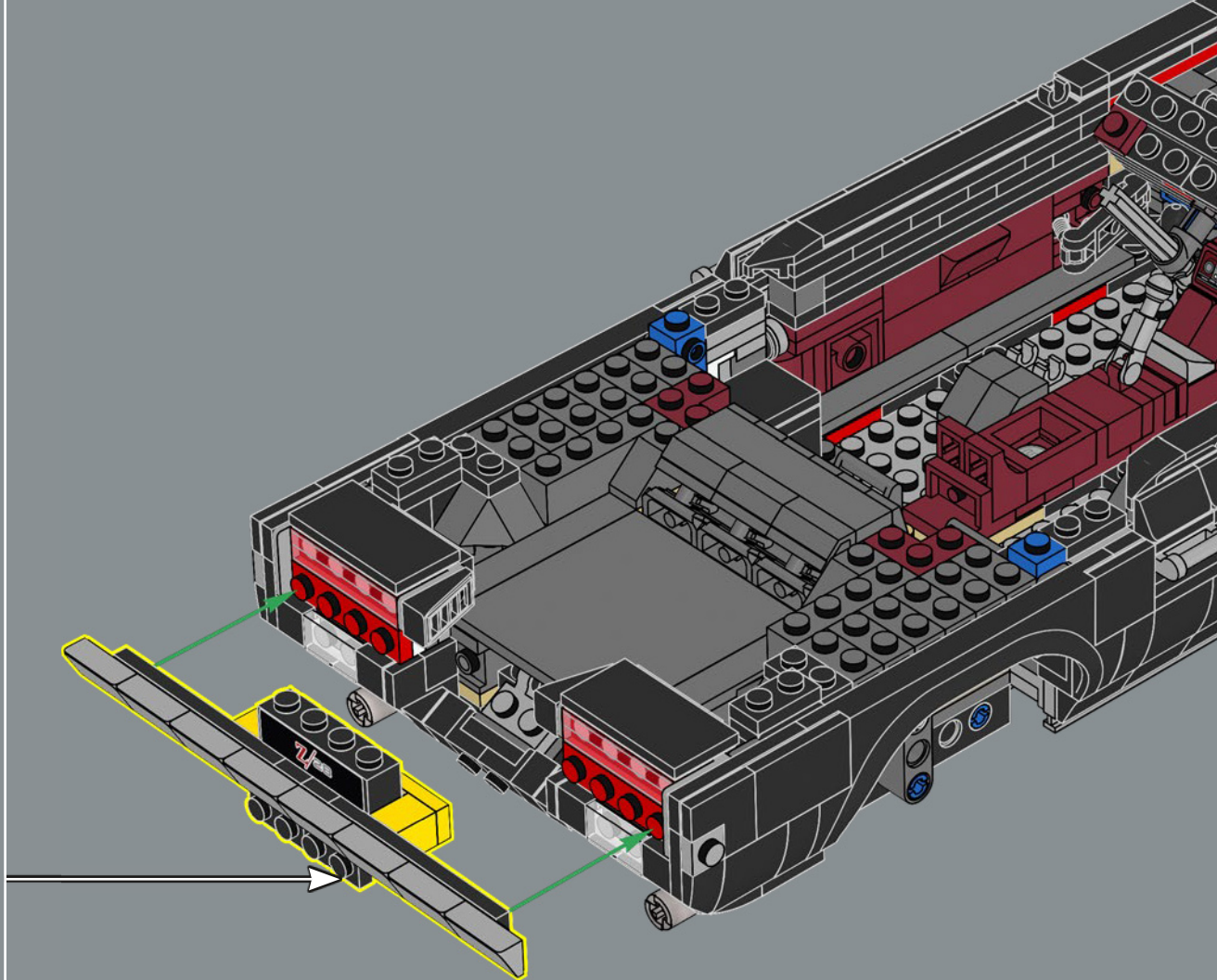

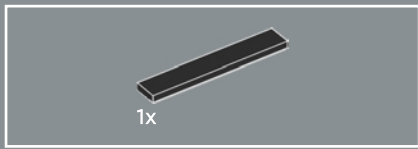

241

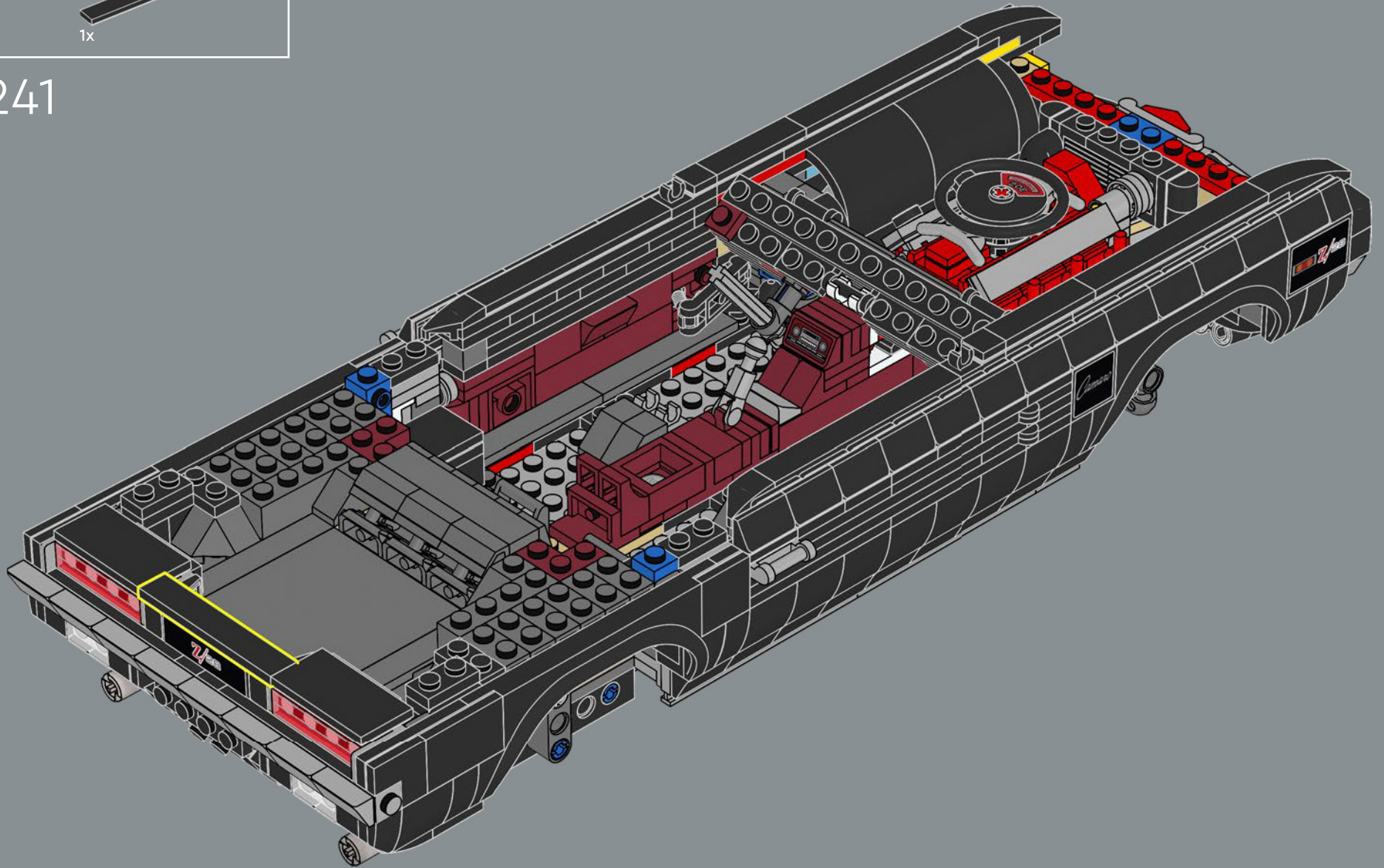

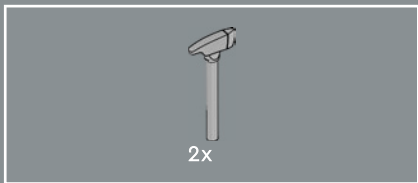

242

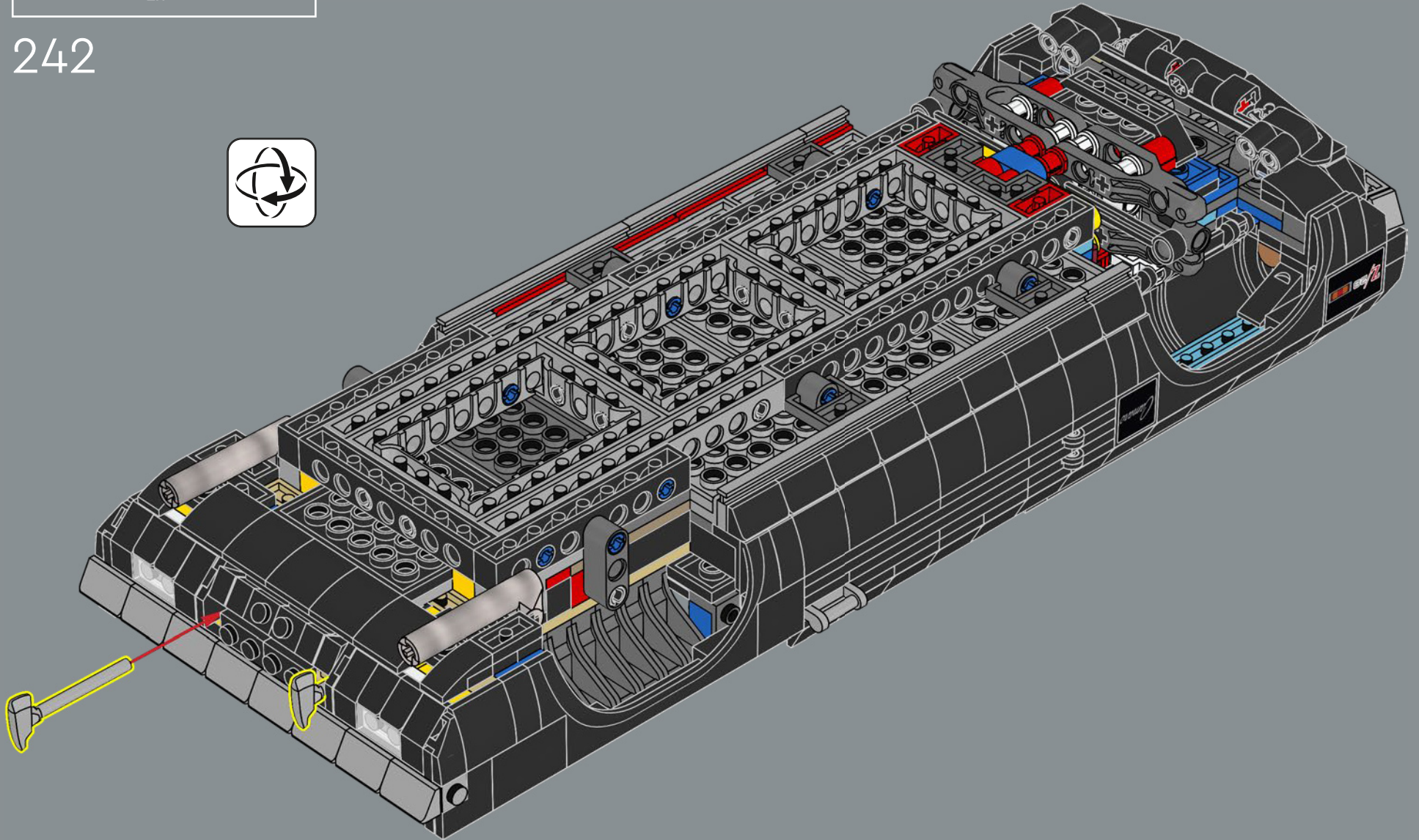

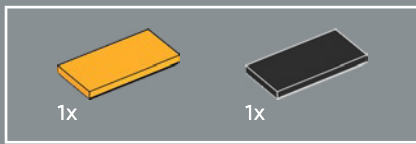

A diferencia de la mayoría de los coches Chevrolet, las 3 primeras generaciones del Camaro no se fabricaron en Detroit, sino en las plantas de Norwood (Ohio) y Van Nuys (California).

243

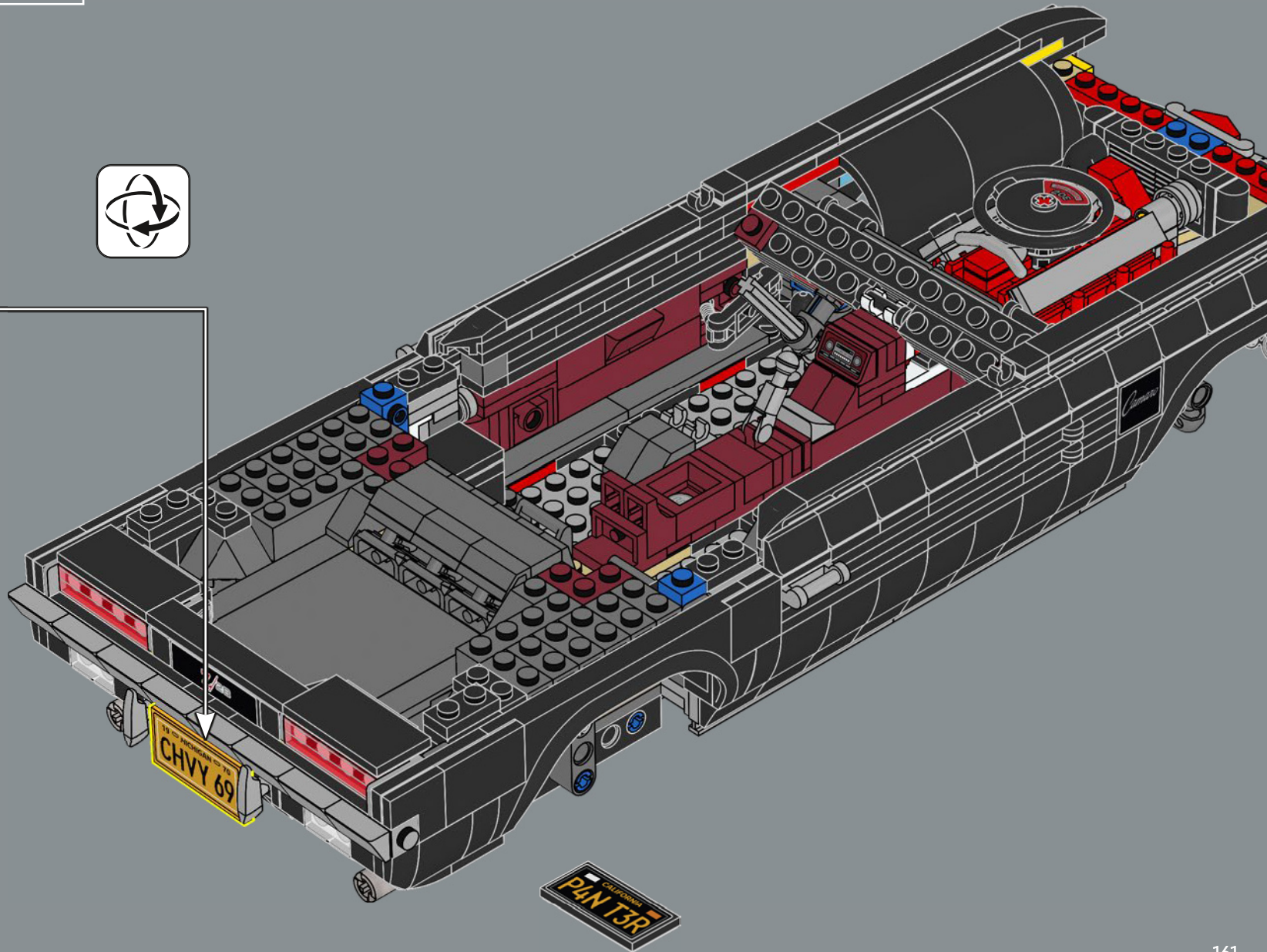
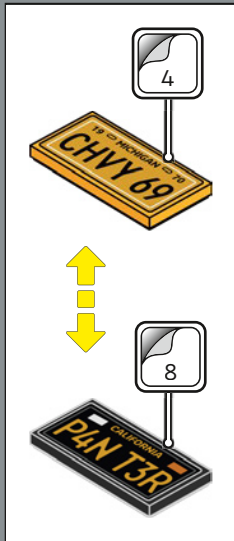

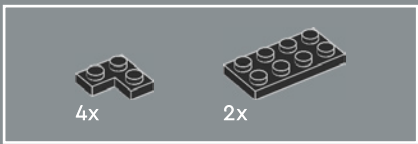

244

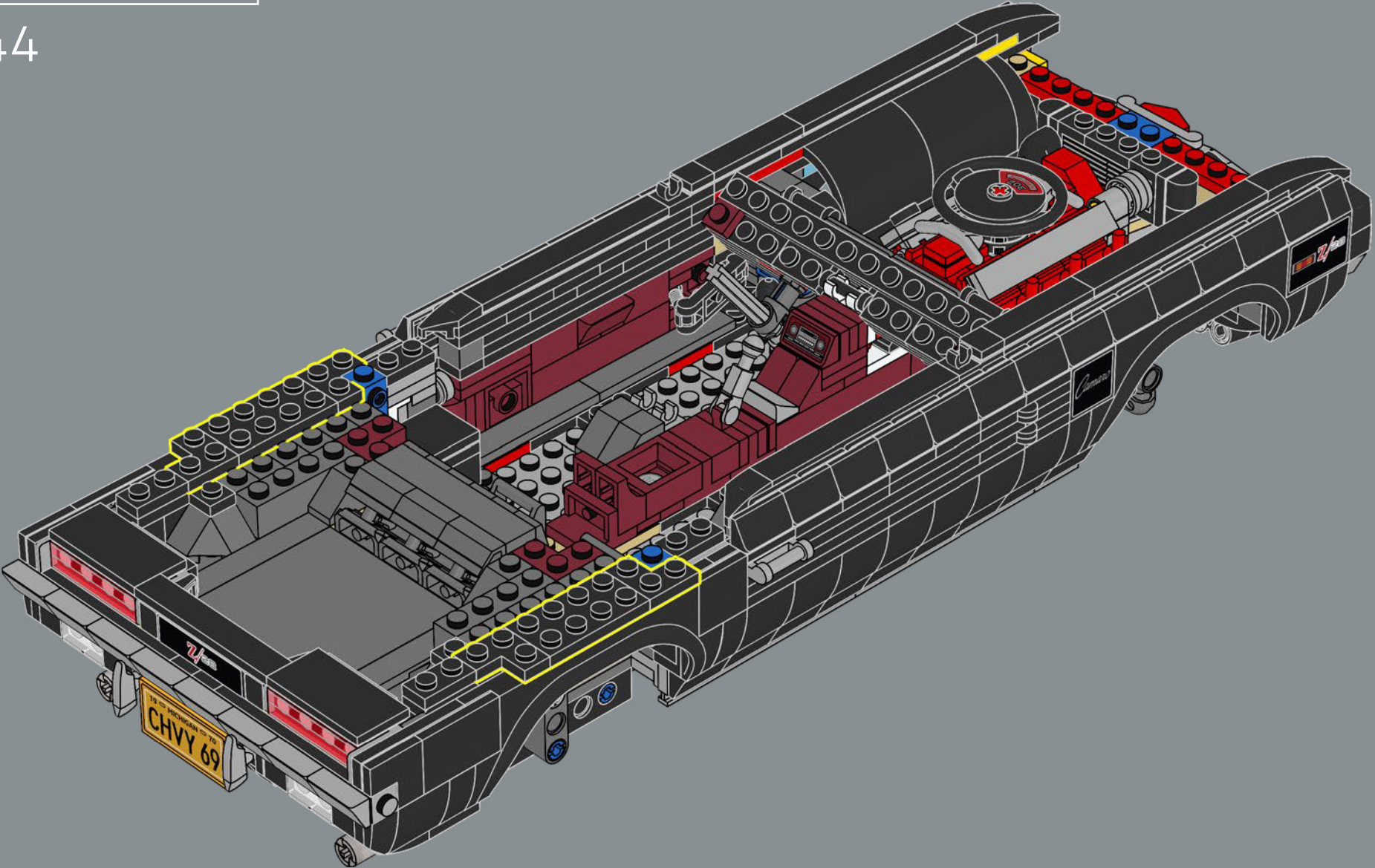

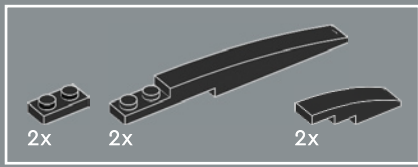

245

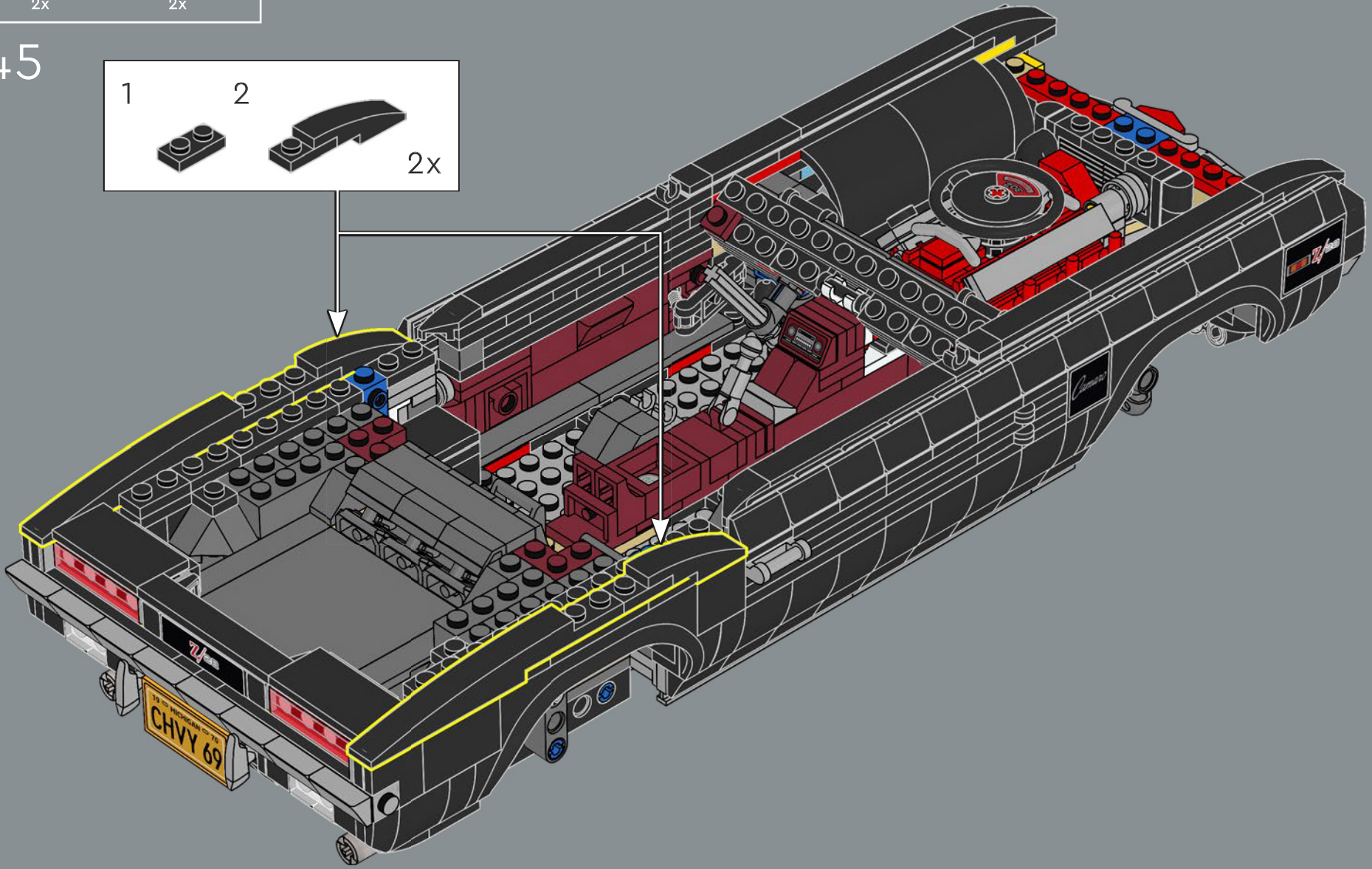
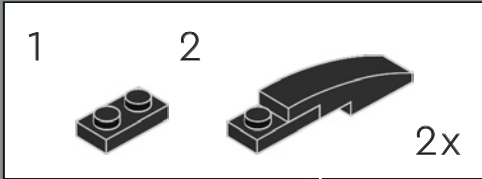

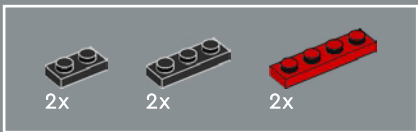

246

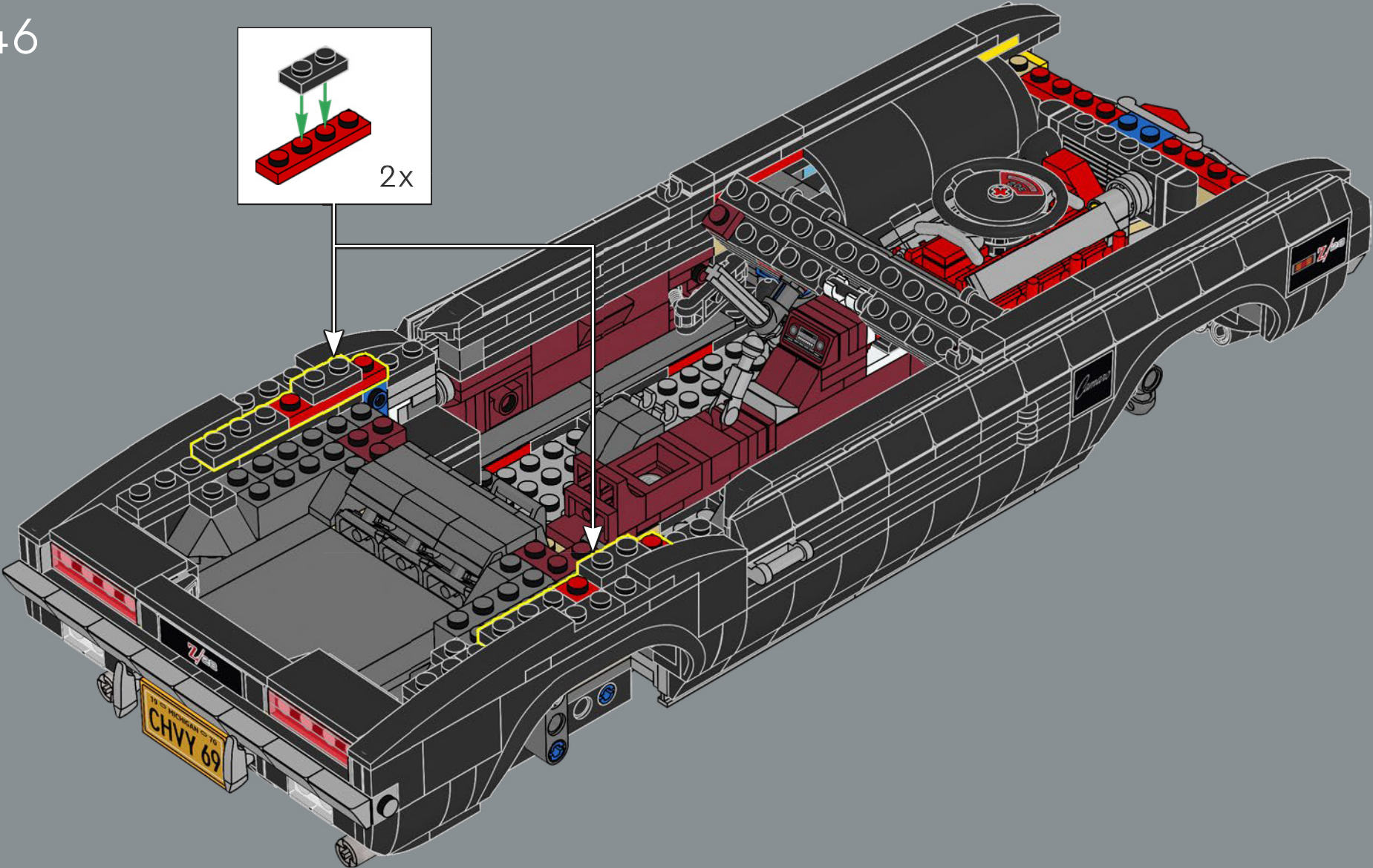
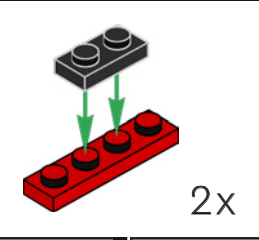

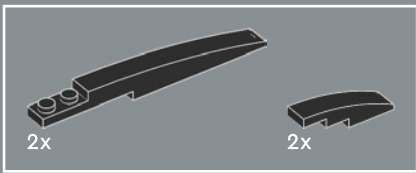

247

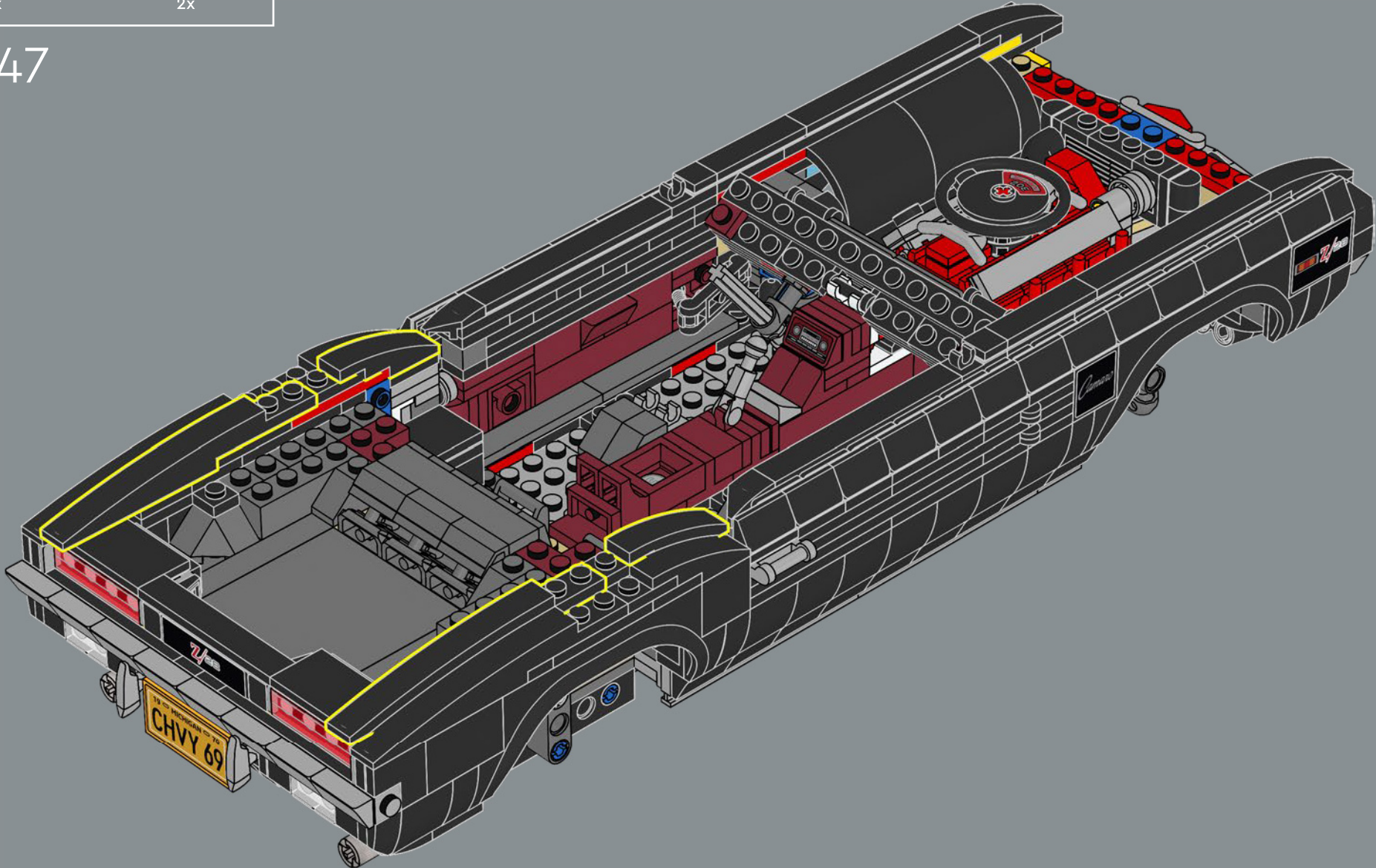

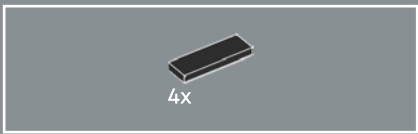

248

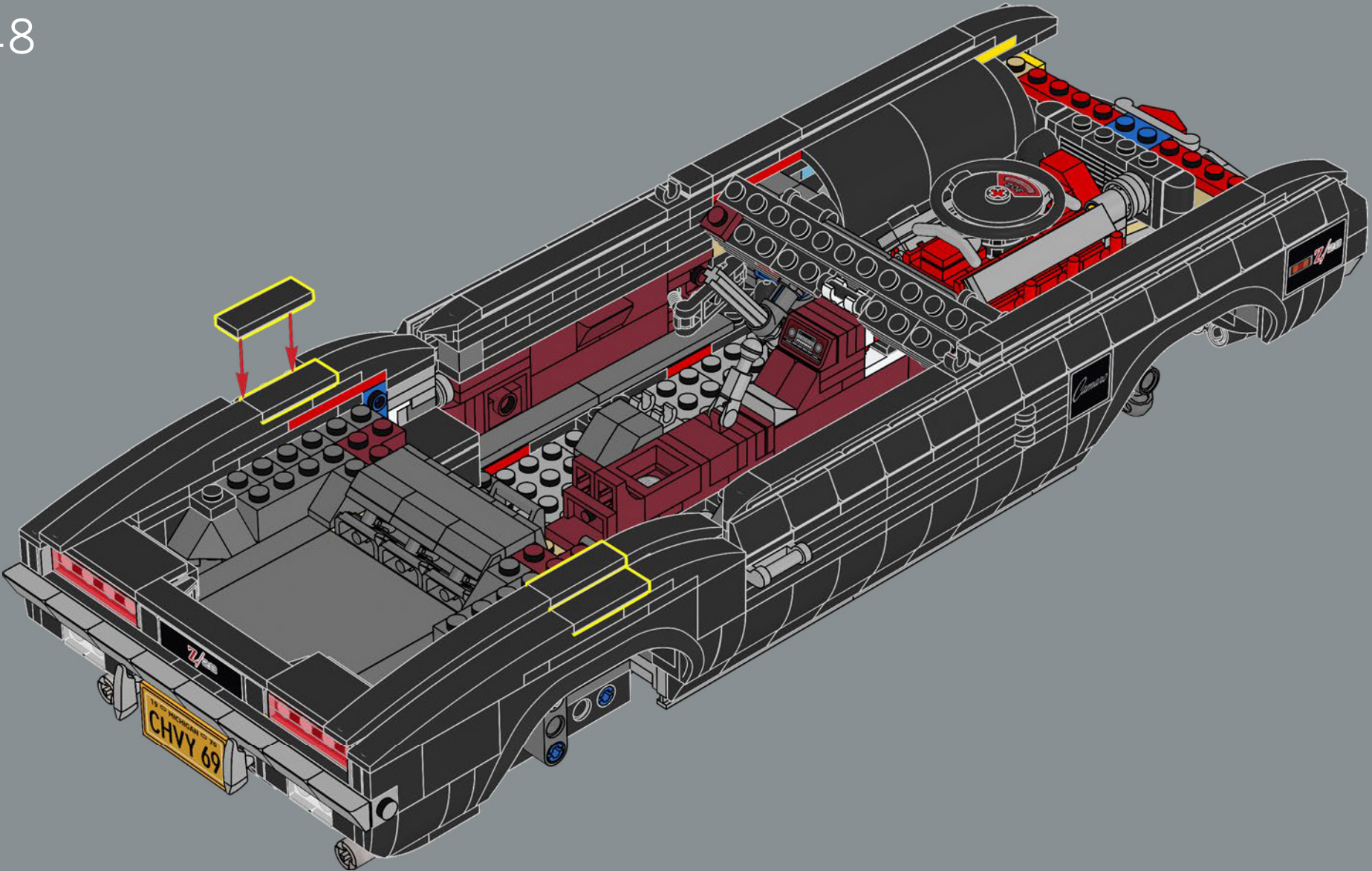

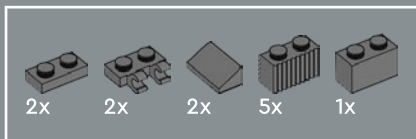

249

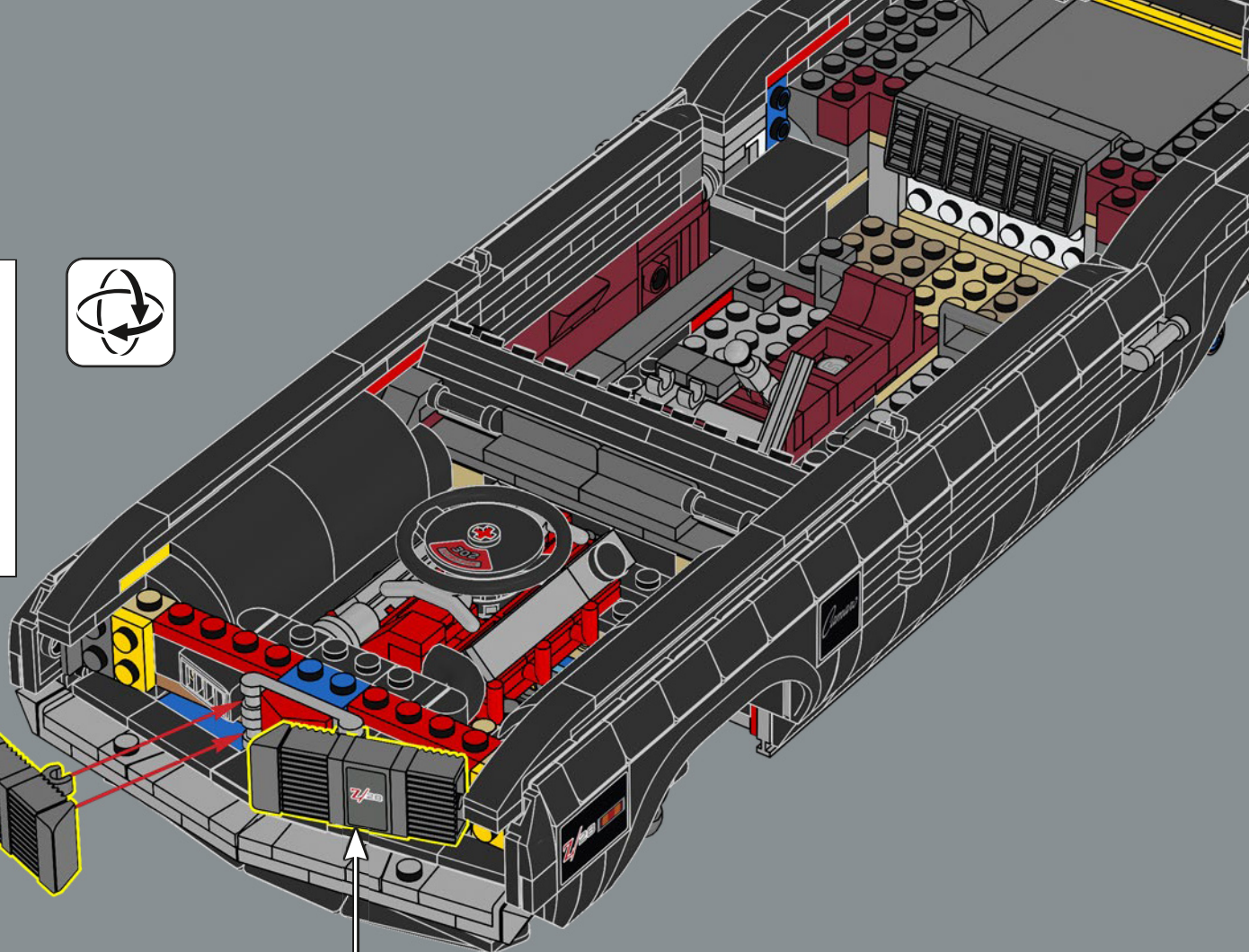
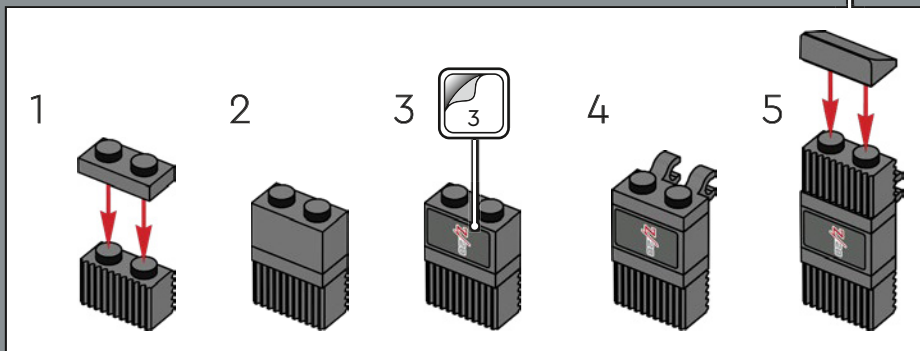
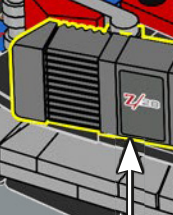
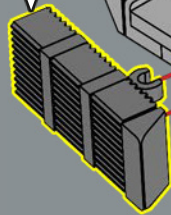
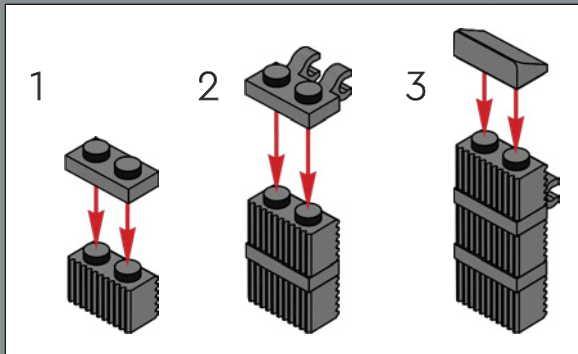

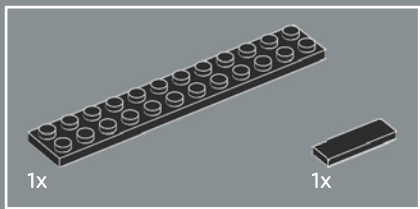

250

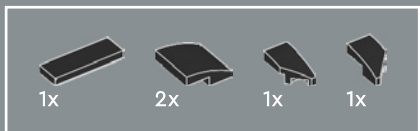
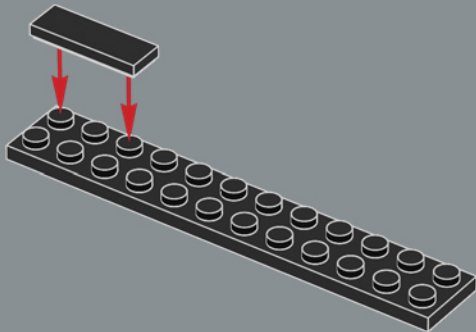

251

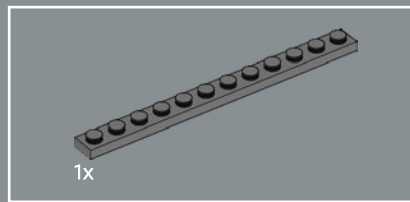
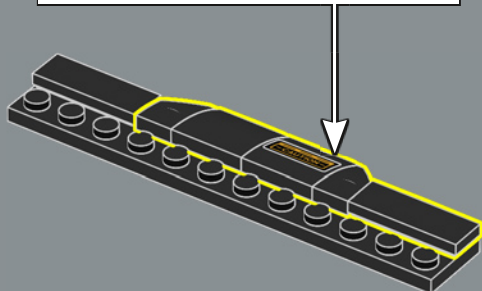
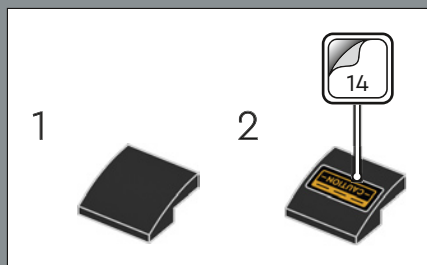

252

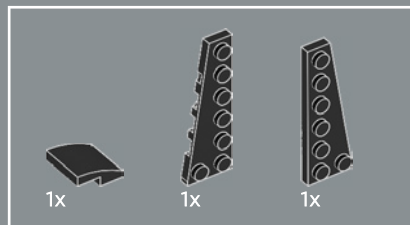
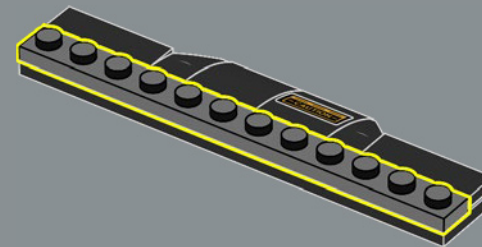

253

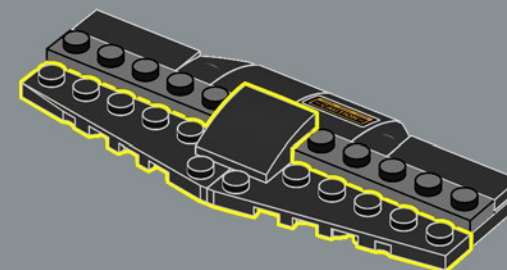



254

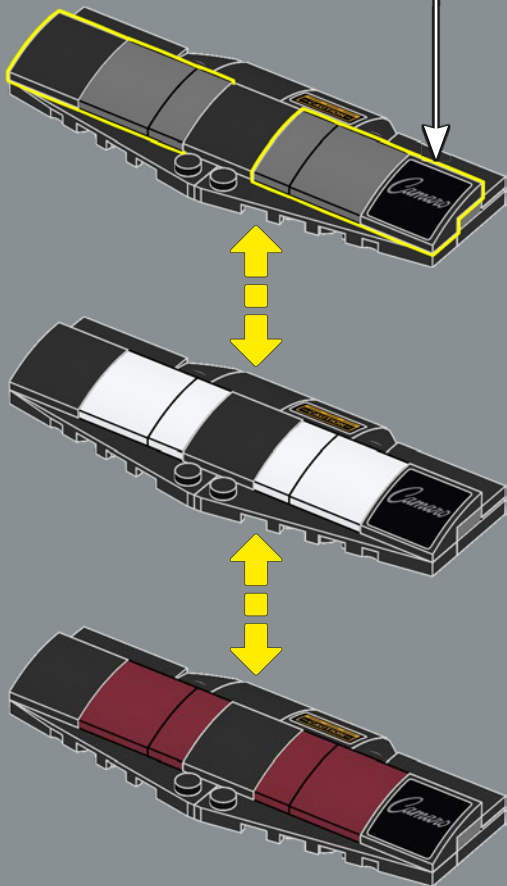
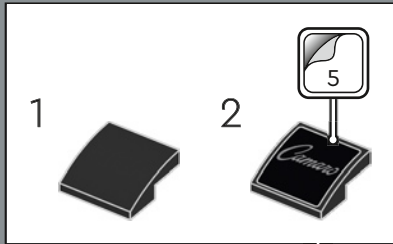

255

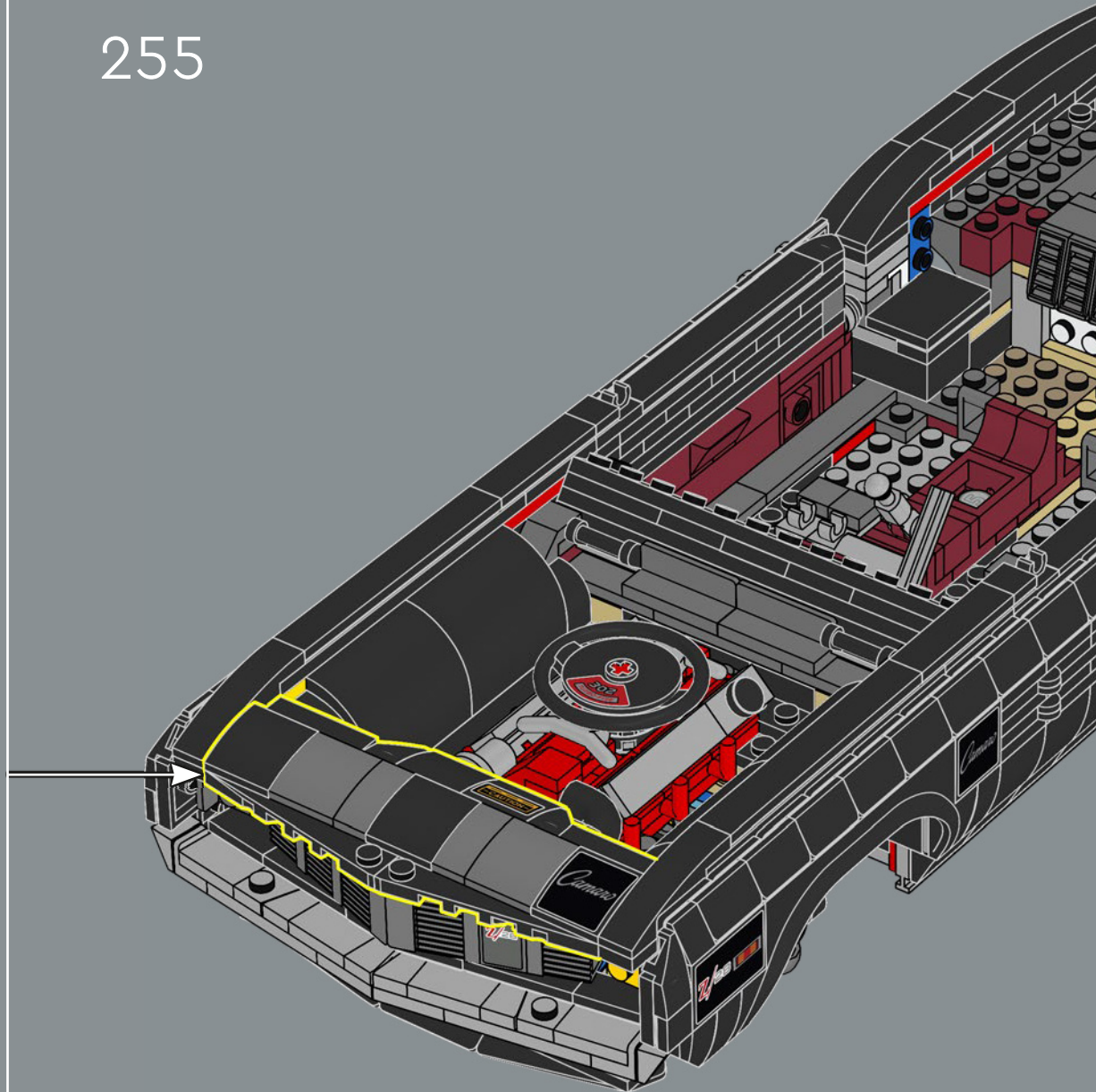

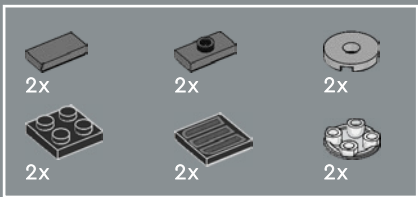

256

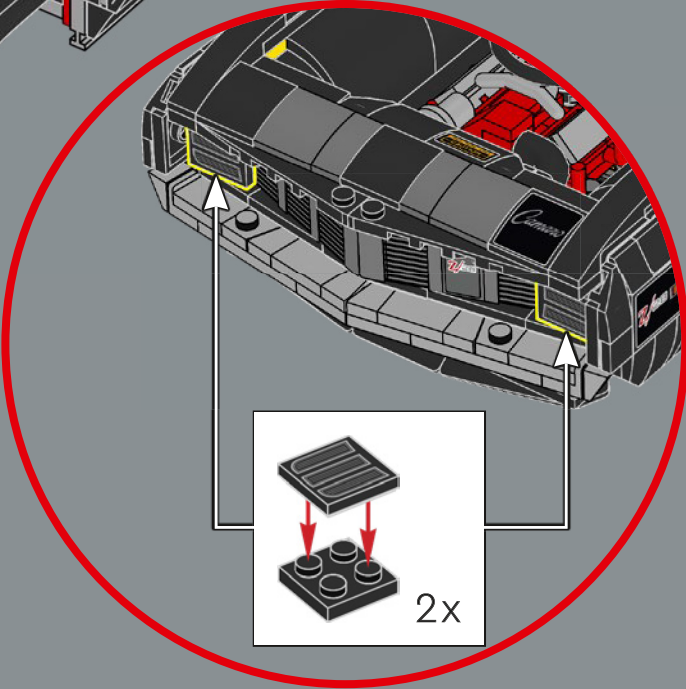
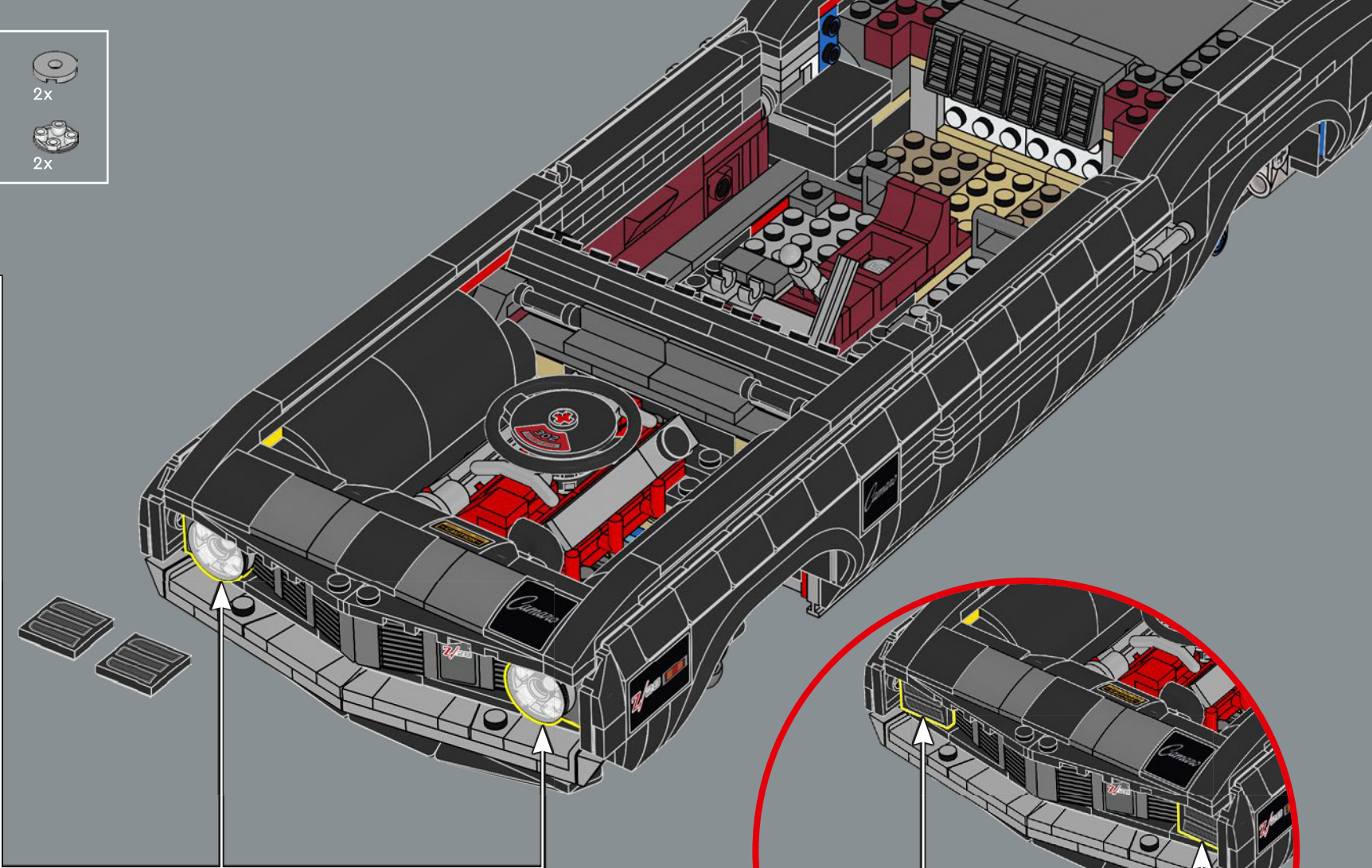
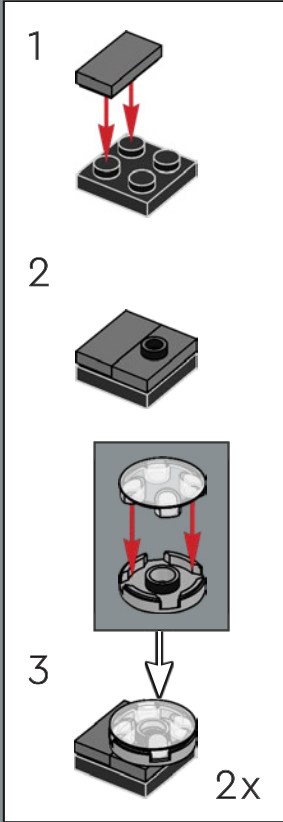

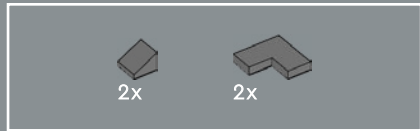

257

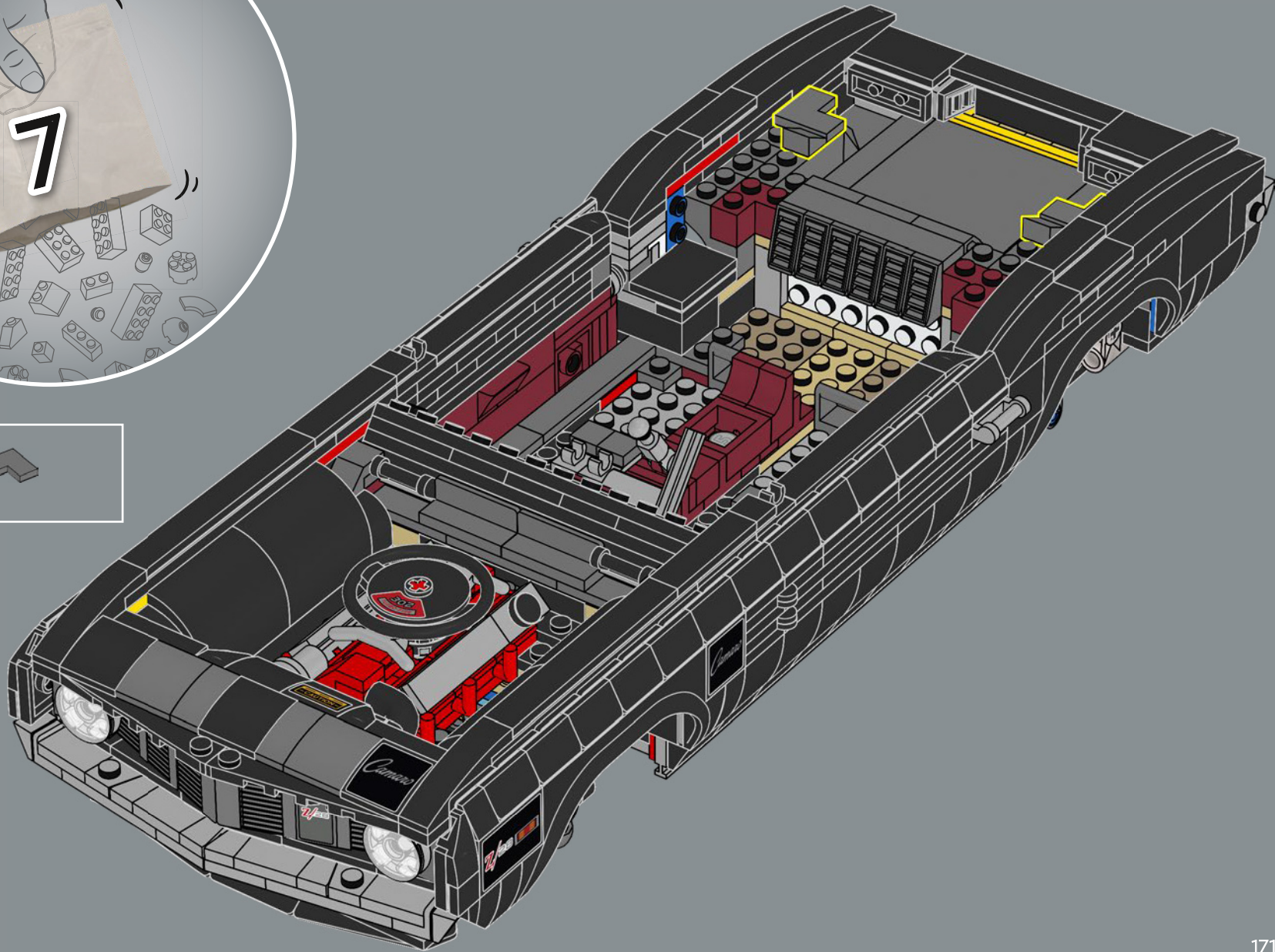

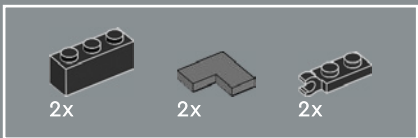

258

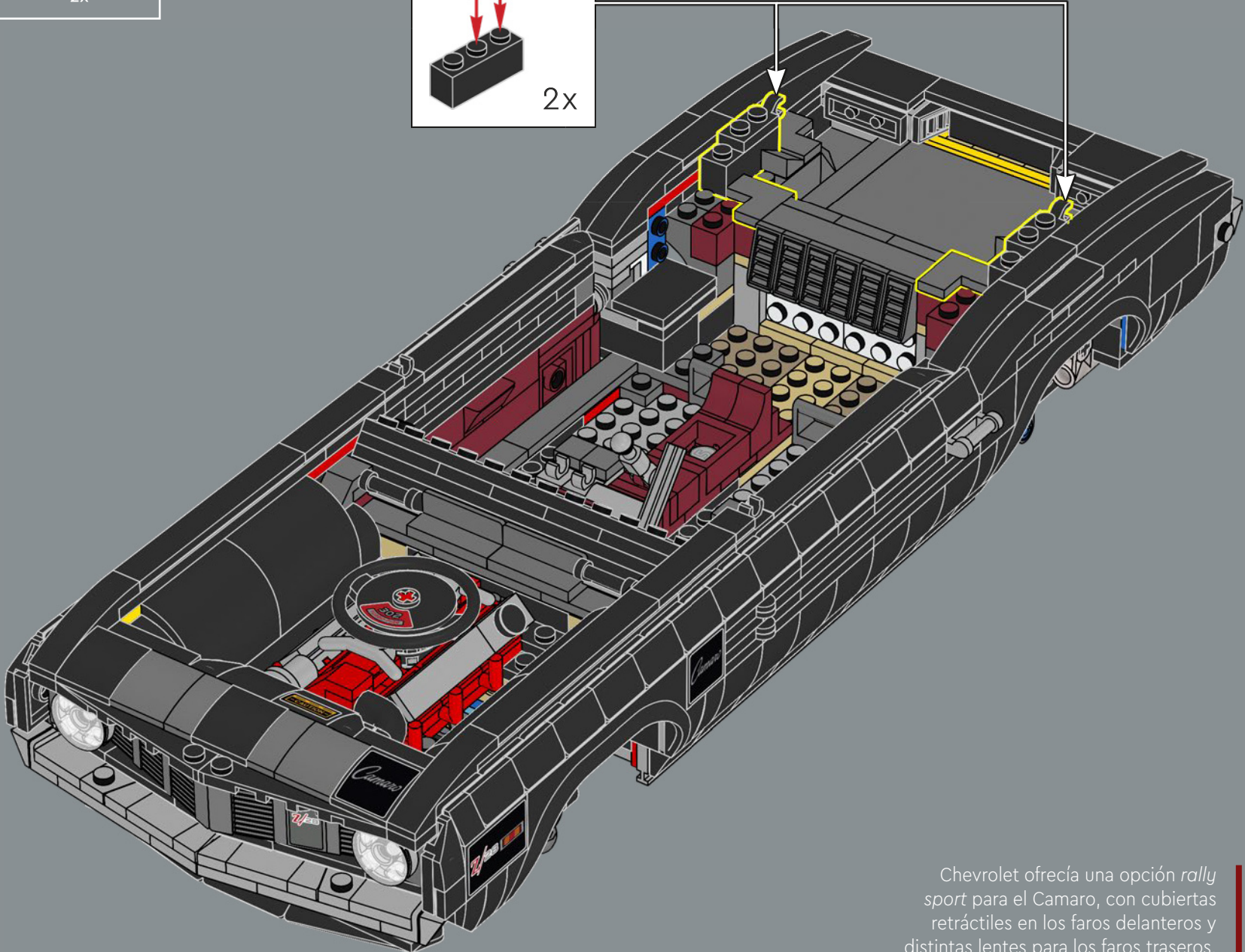
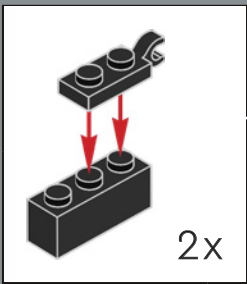

Chevrolet ofrecía una opción *rally sport* para el Camaro, con cubiertas retráctiles en los faros delanteros y distintas lentes para los faros traseros.

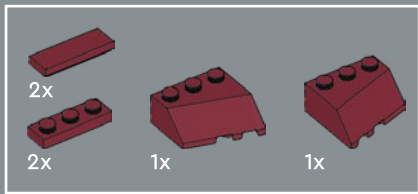

259

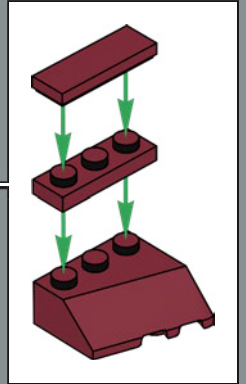
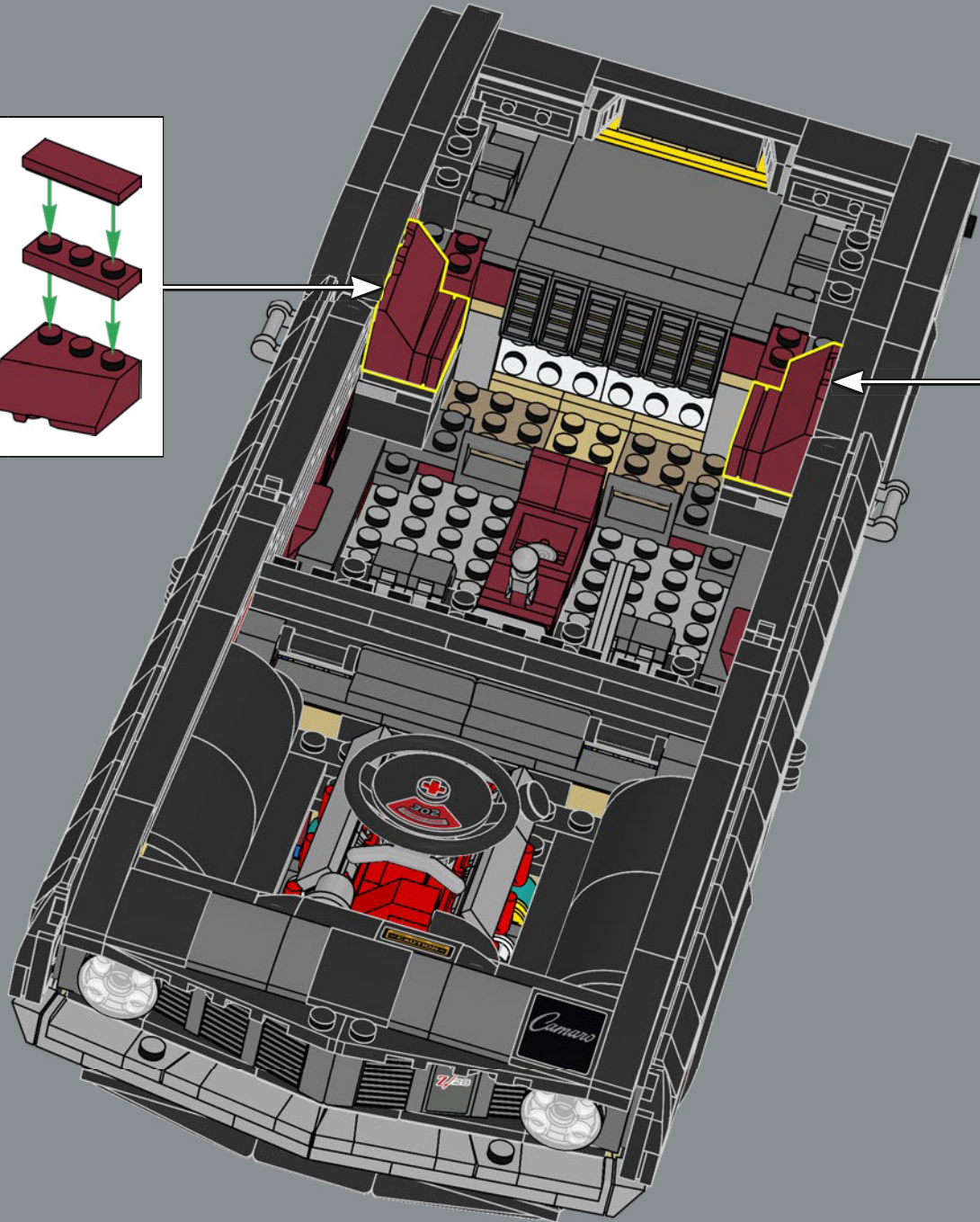
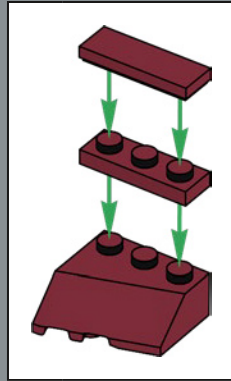

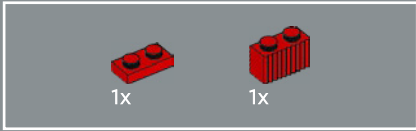

260

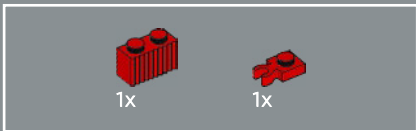
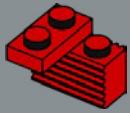

261

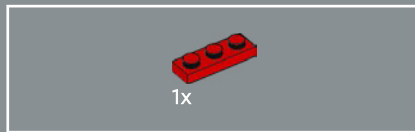
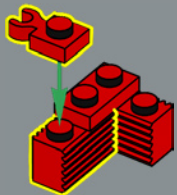

262

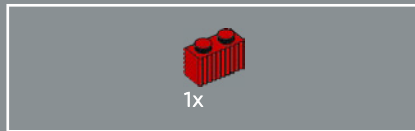
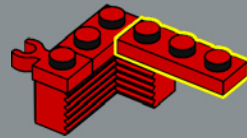

263

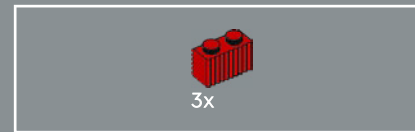
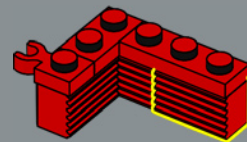

264

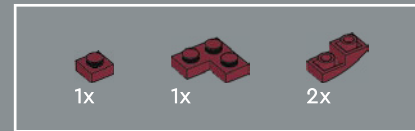
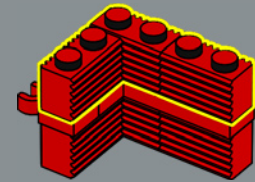

265

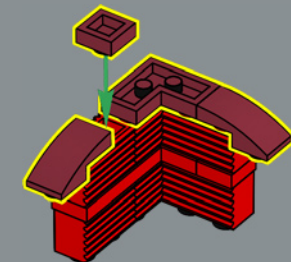

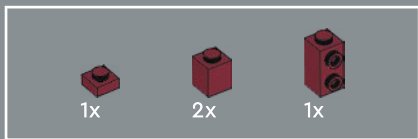

266

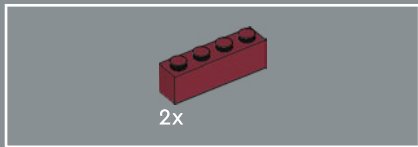
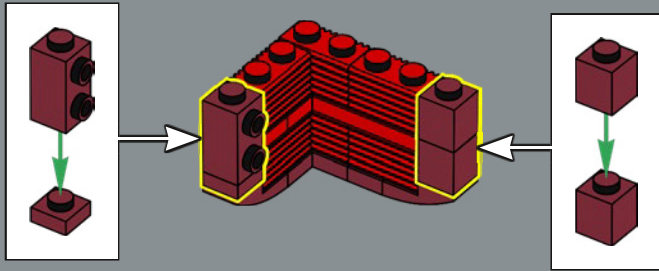

267

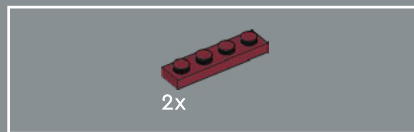
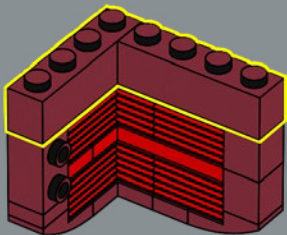

268

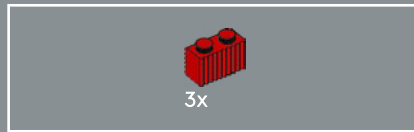
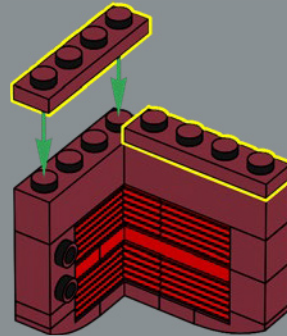

269

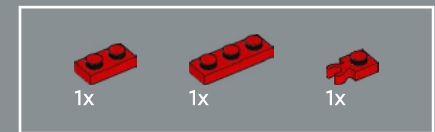
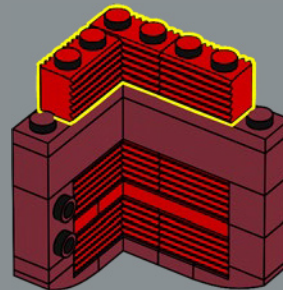

270

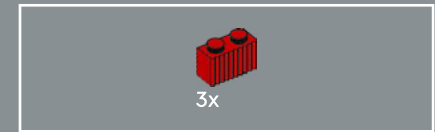
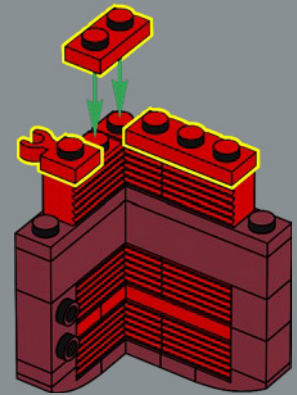

271

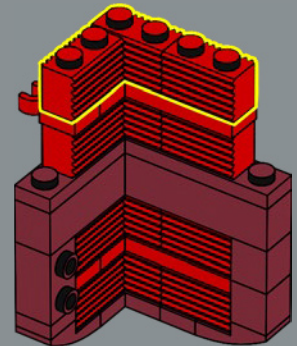



4x

272

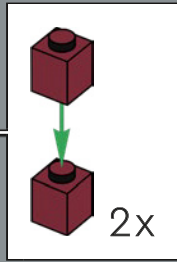
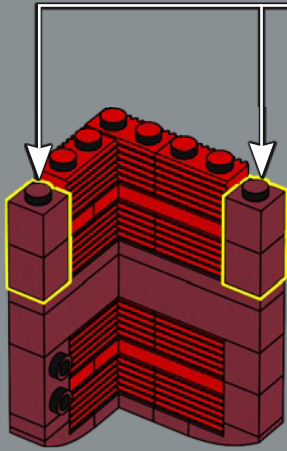

2x

1x

2x

1x

273

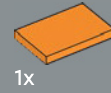
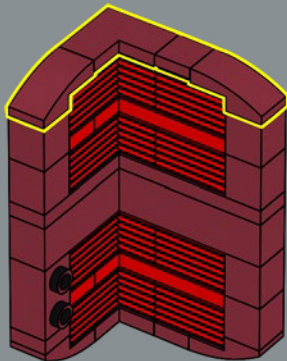

1x

274



15

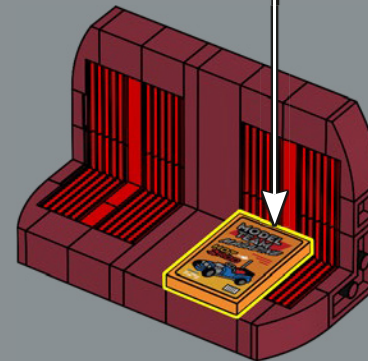

275

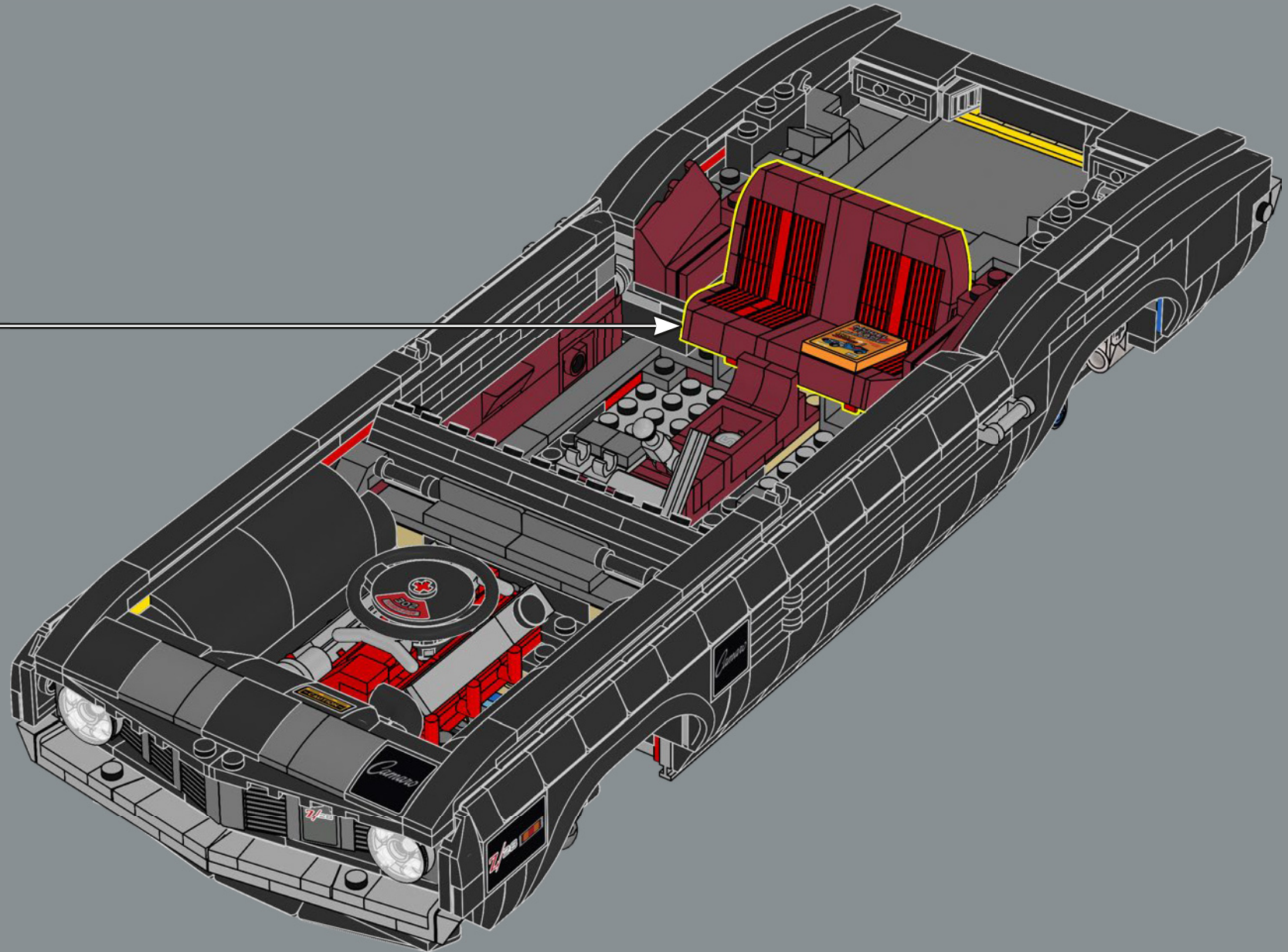

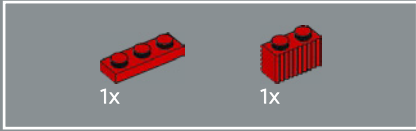

276

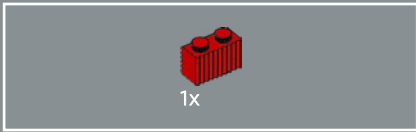
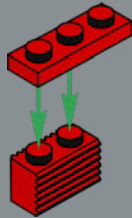

277

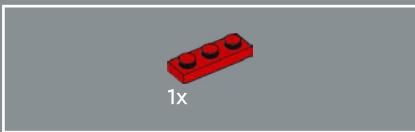
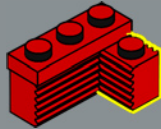

278

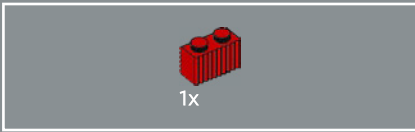
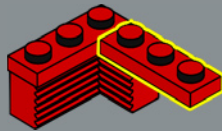

279

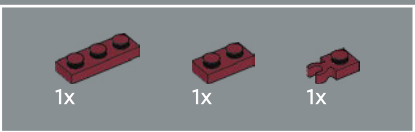
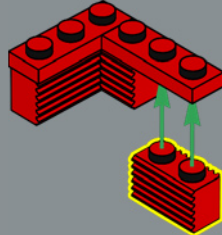

280

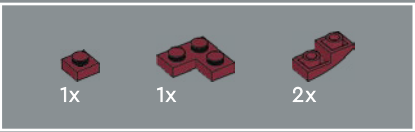
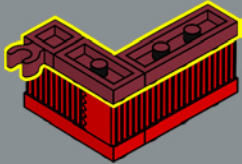

281

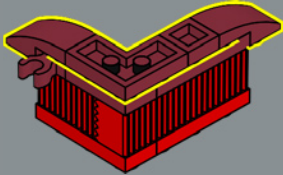



282

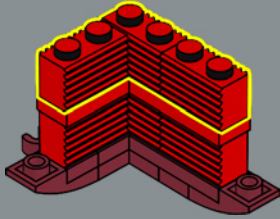

283

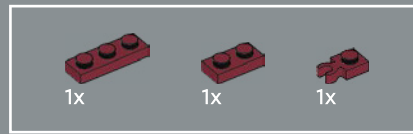
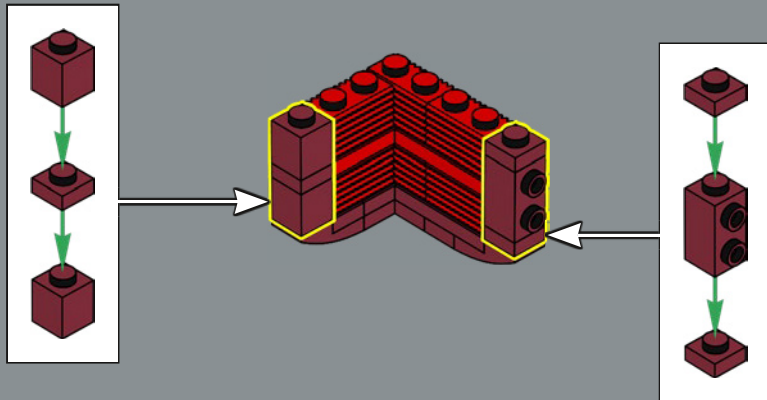

284

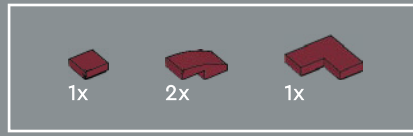
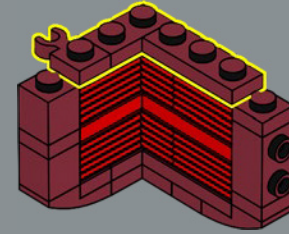

285

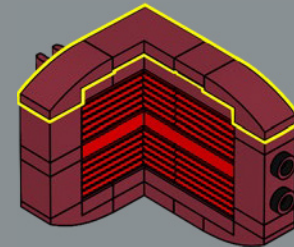



1x

286

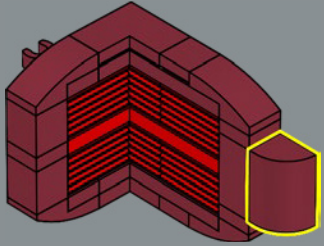

1x

287

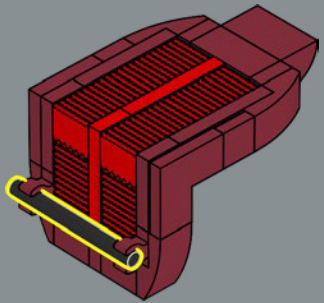

288

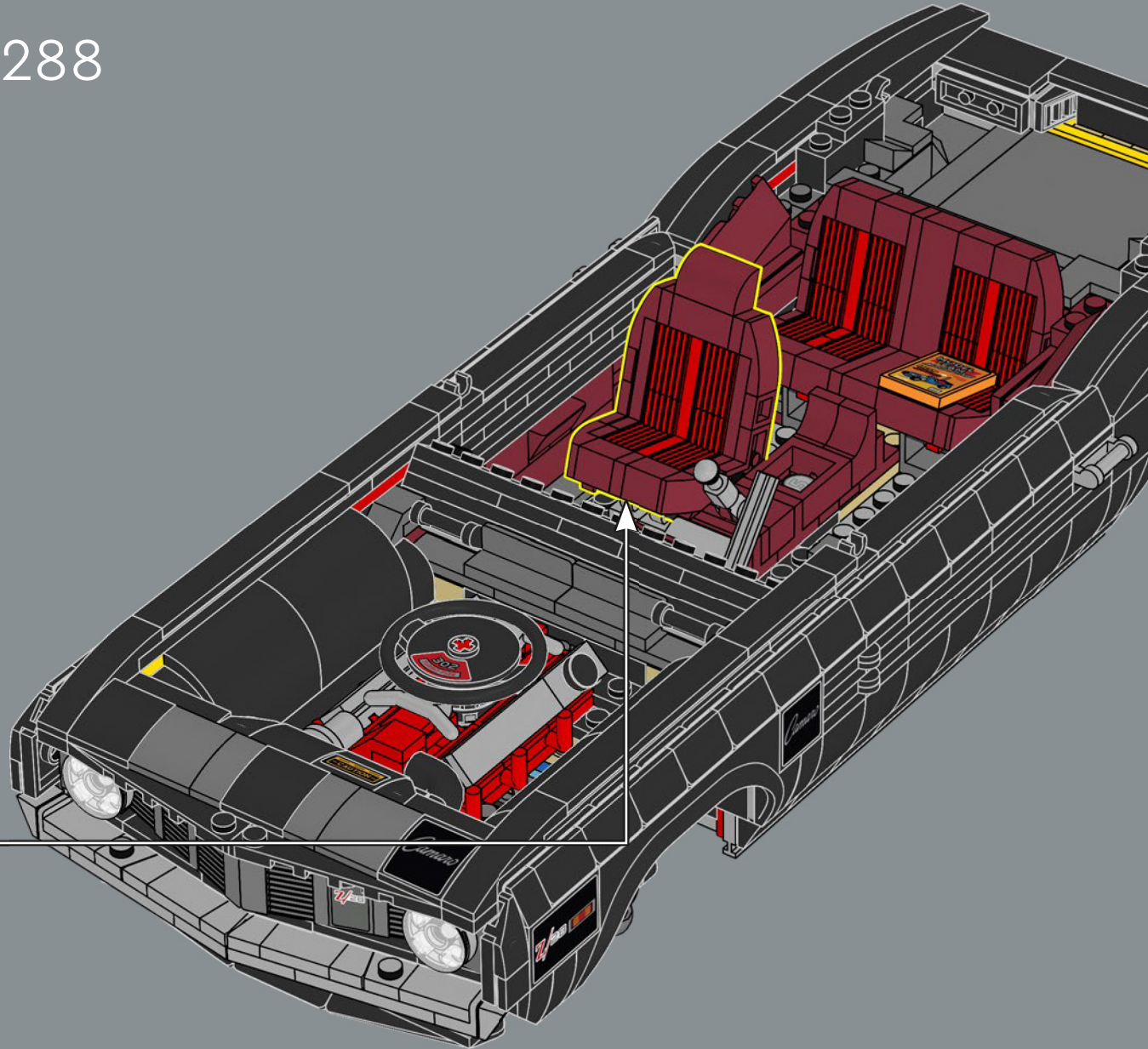

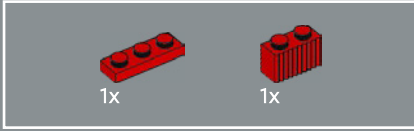
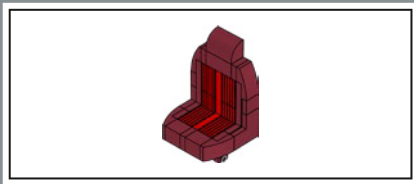

289

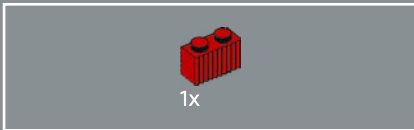
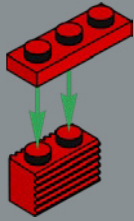

290

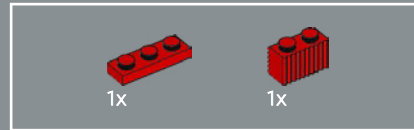
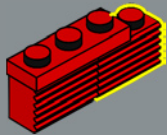

291

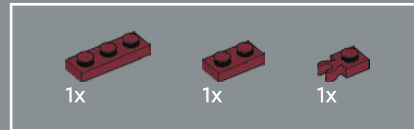
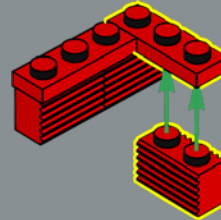

292

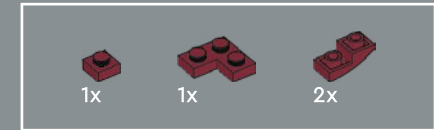
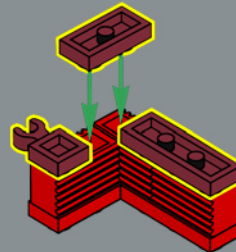

293

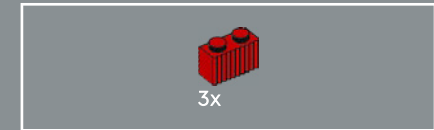
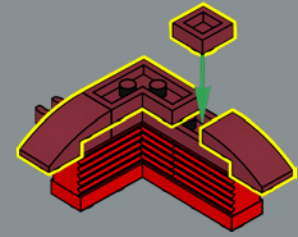

294

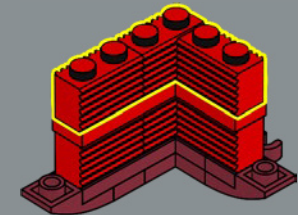



295

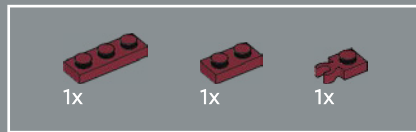
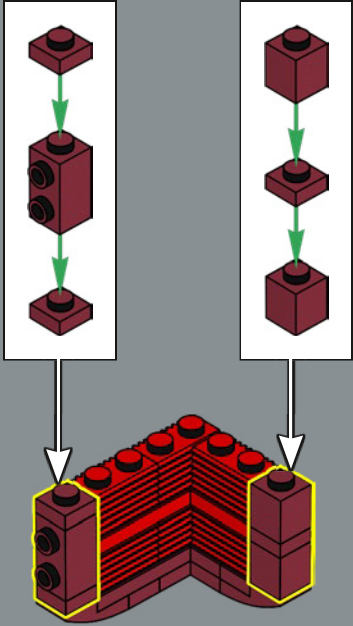

296

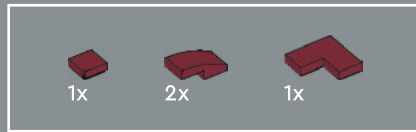
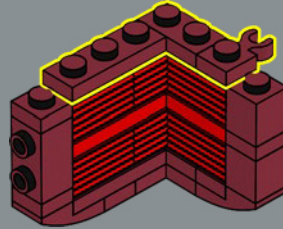

297

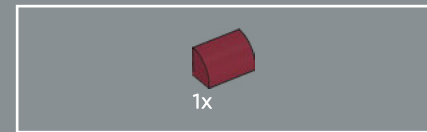
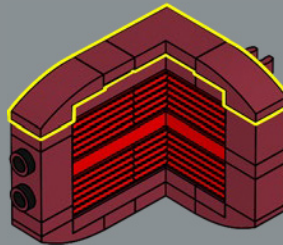

298

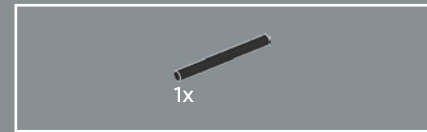
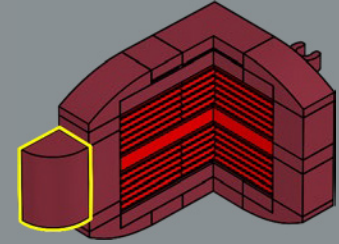

299

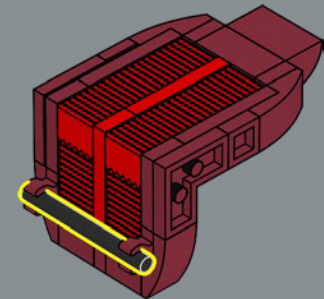

300

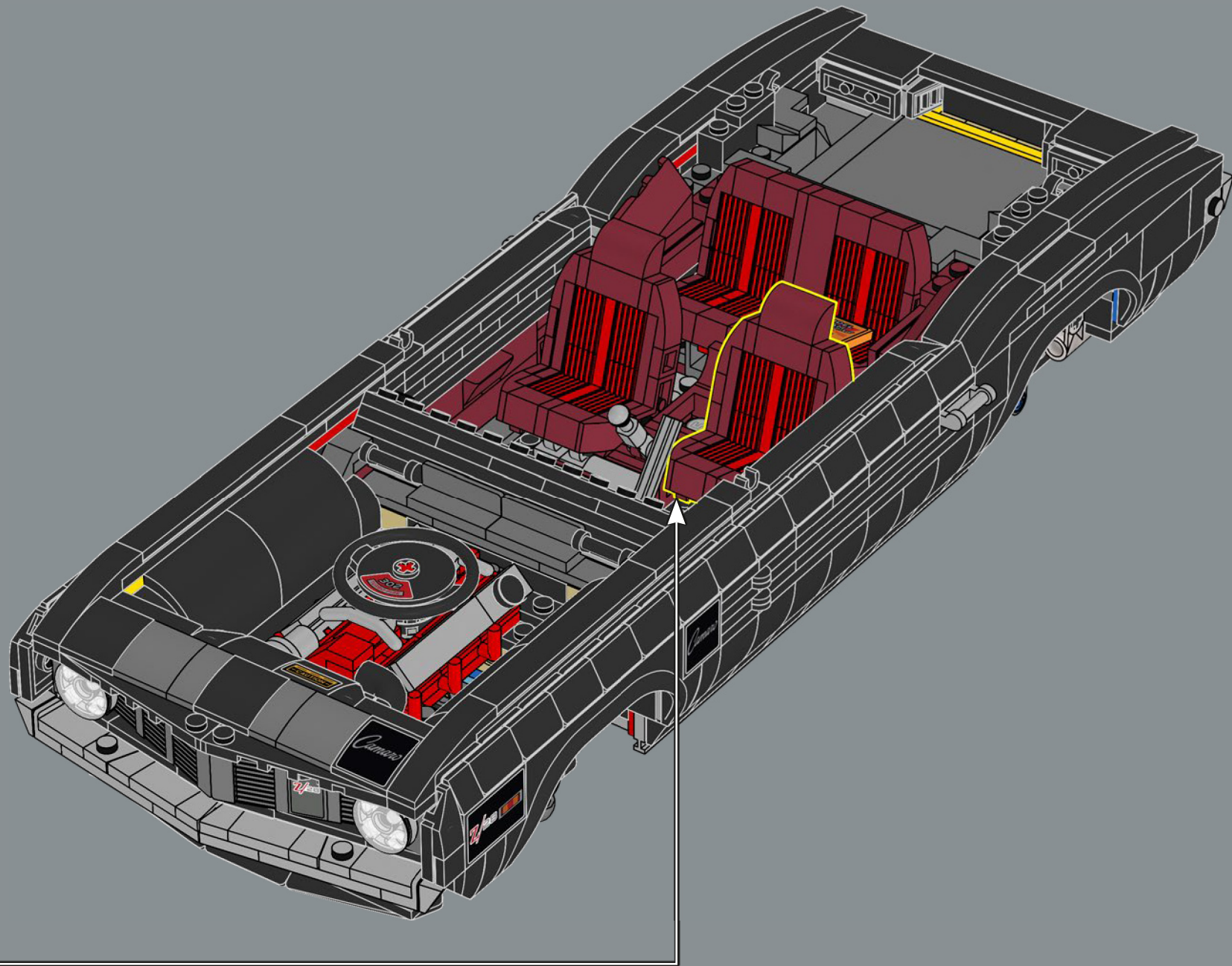

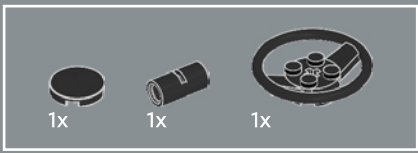

301

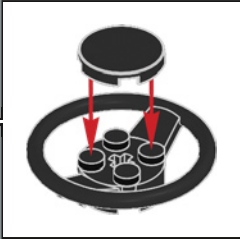
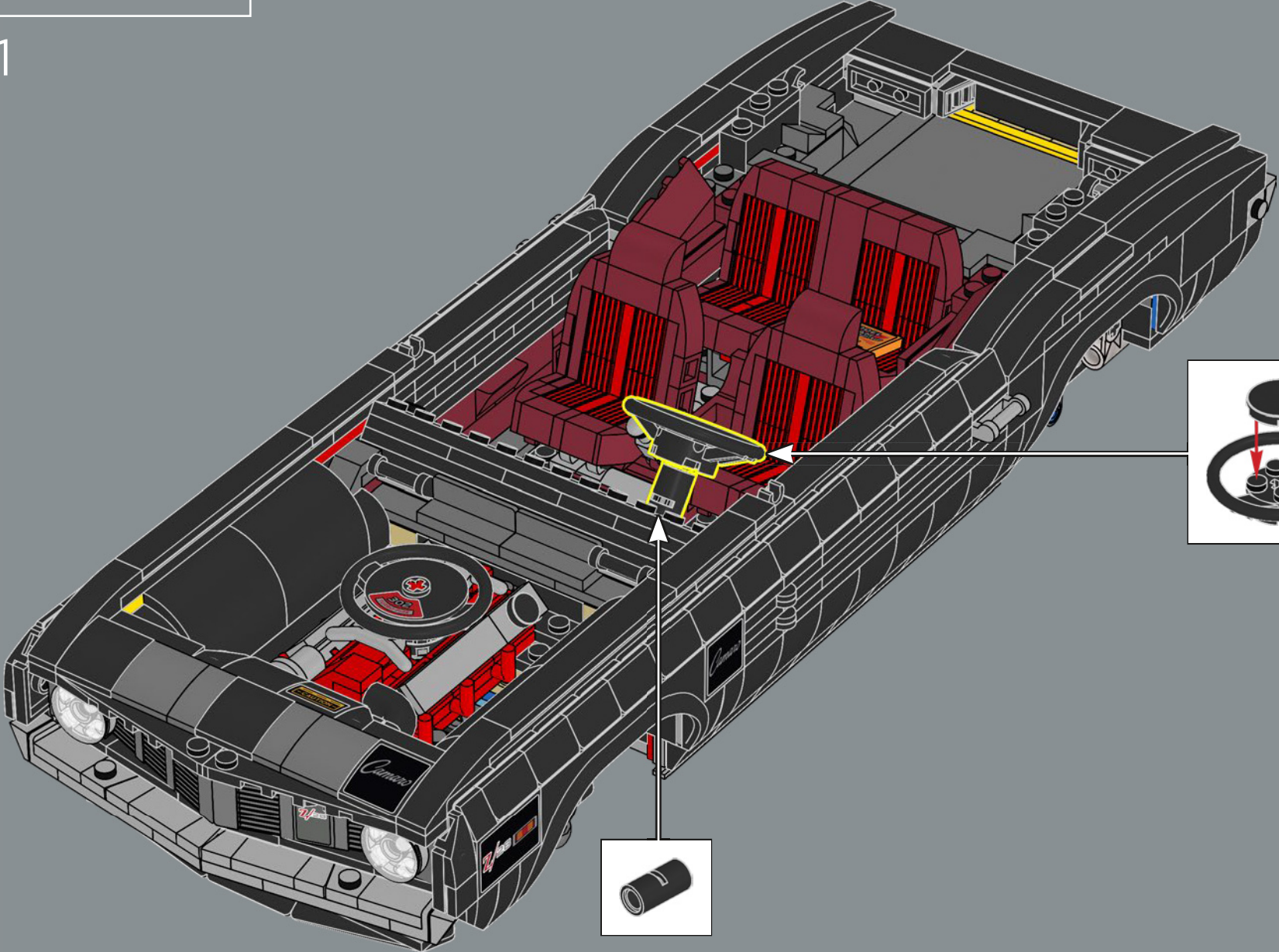

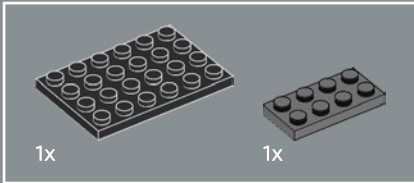
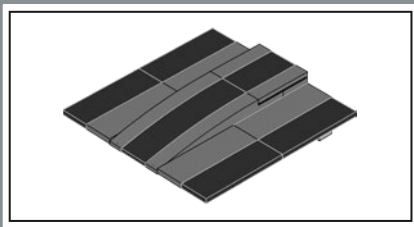

302

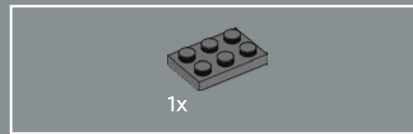
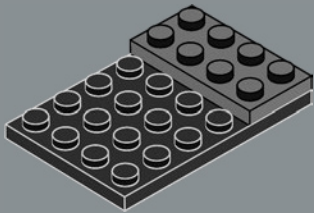

303

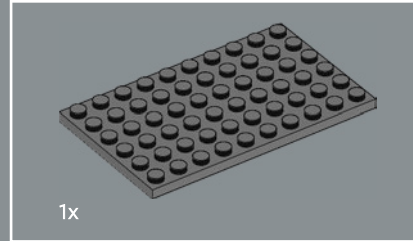
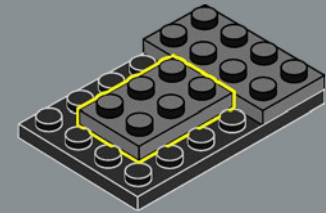

304

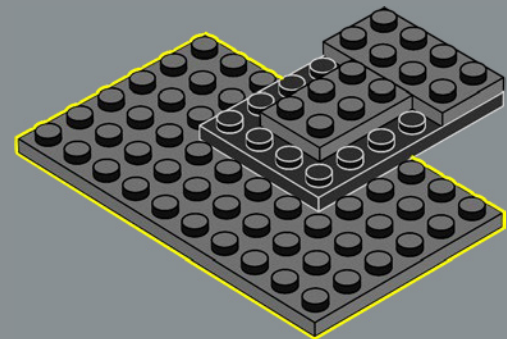

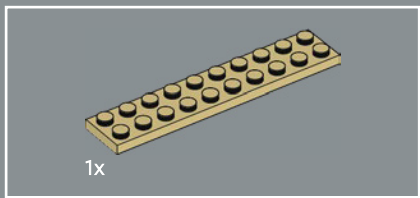

305

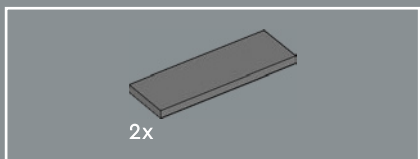
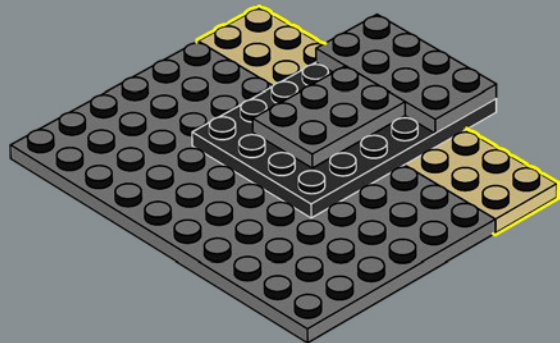

306

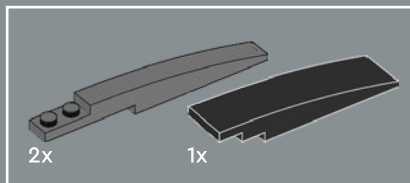
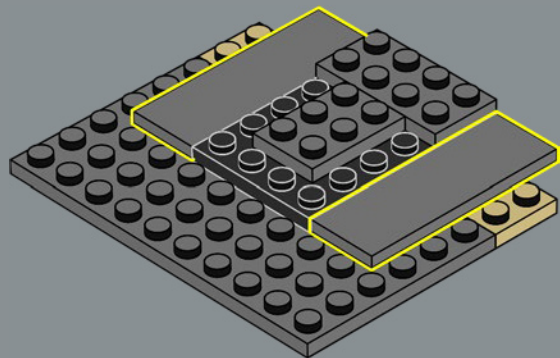

307

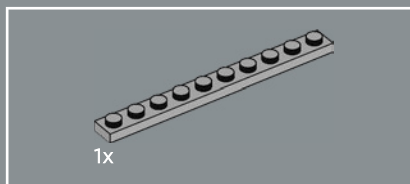
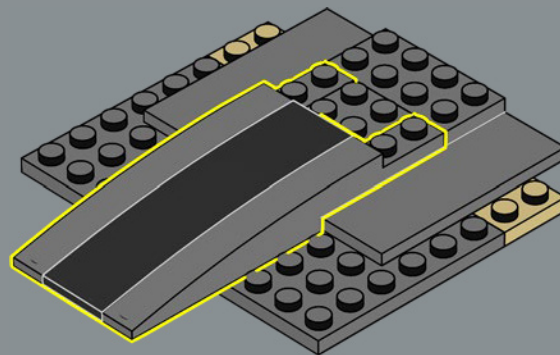

308

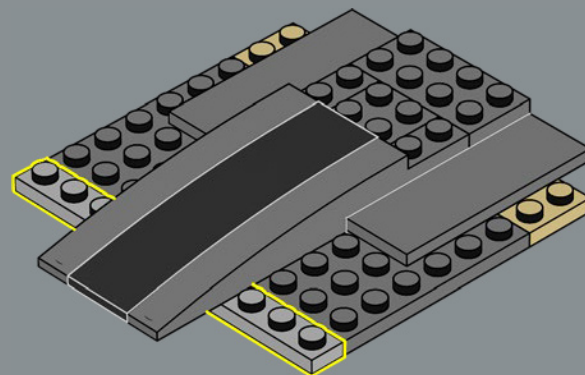

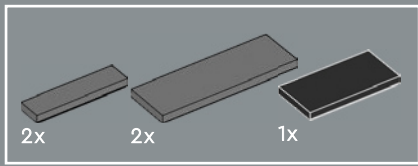

309

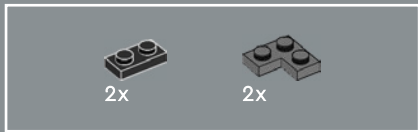
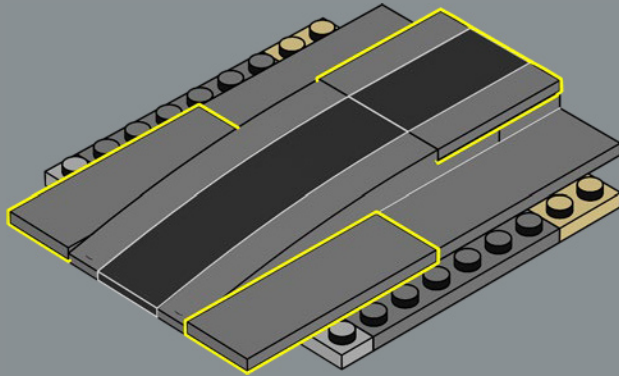

310

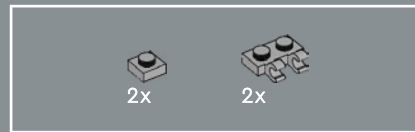
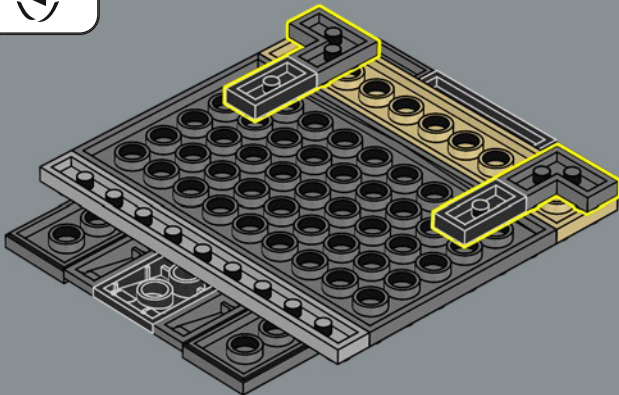

311

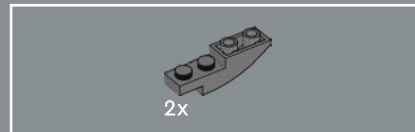
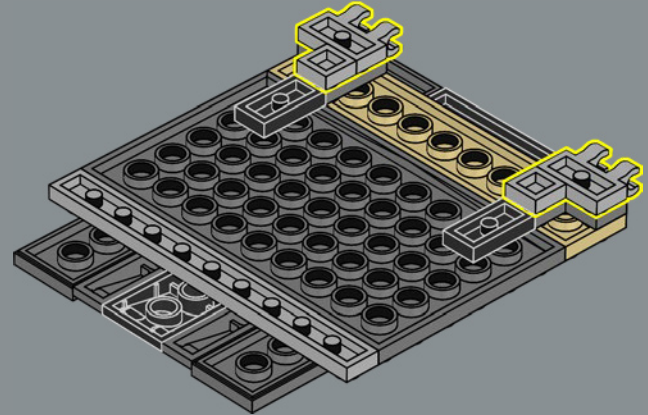

312

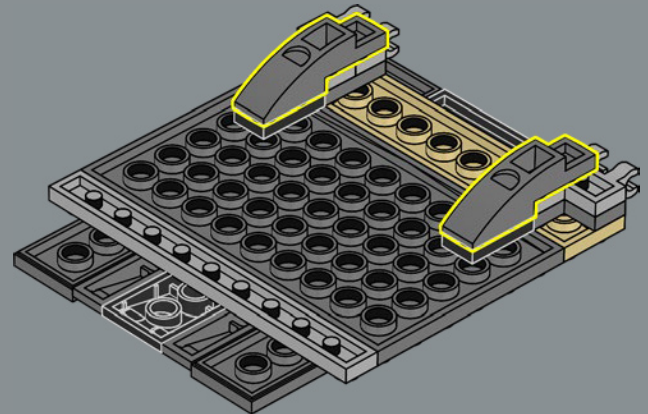

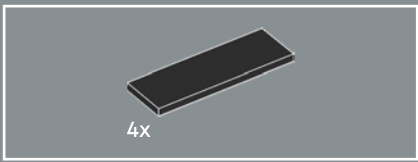

313

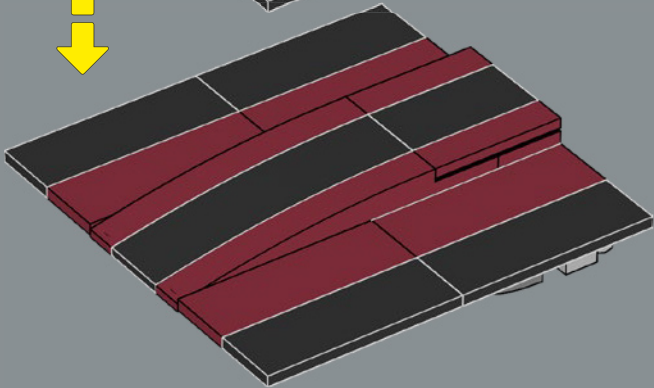
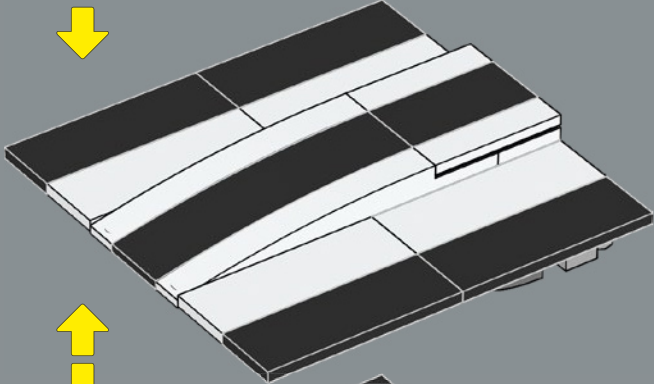
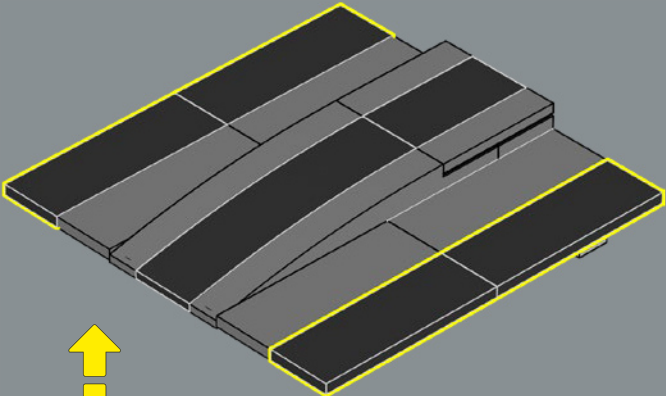

314

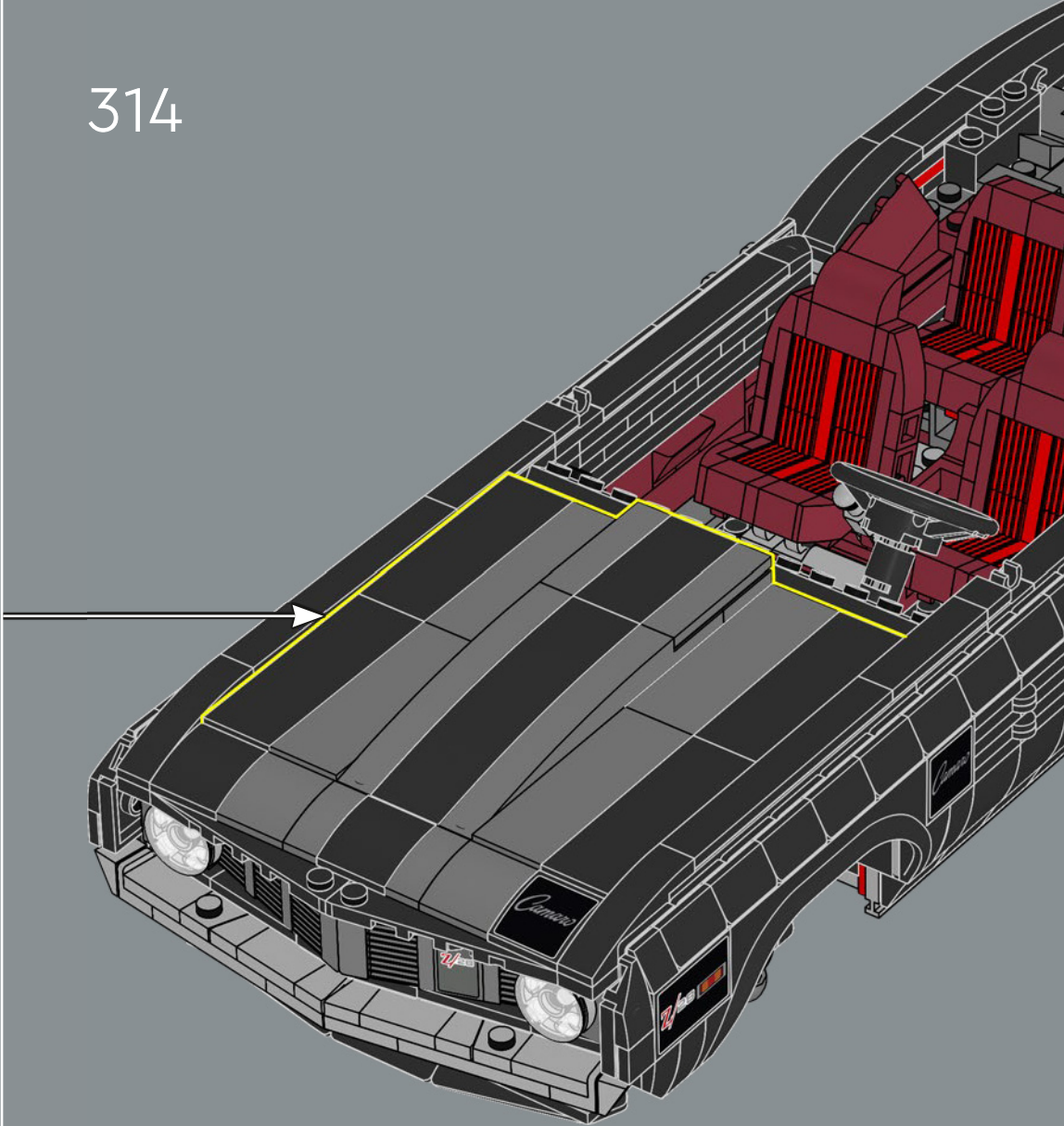

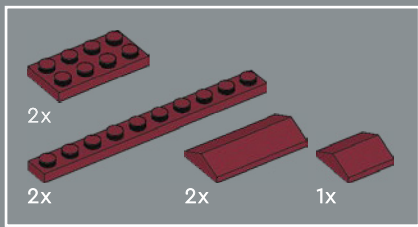

315

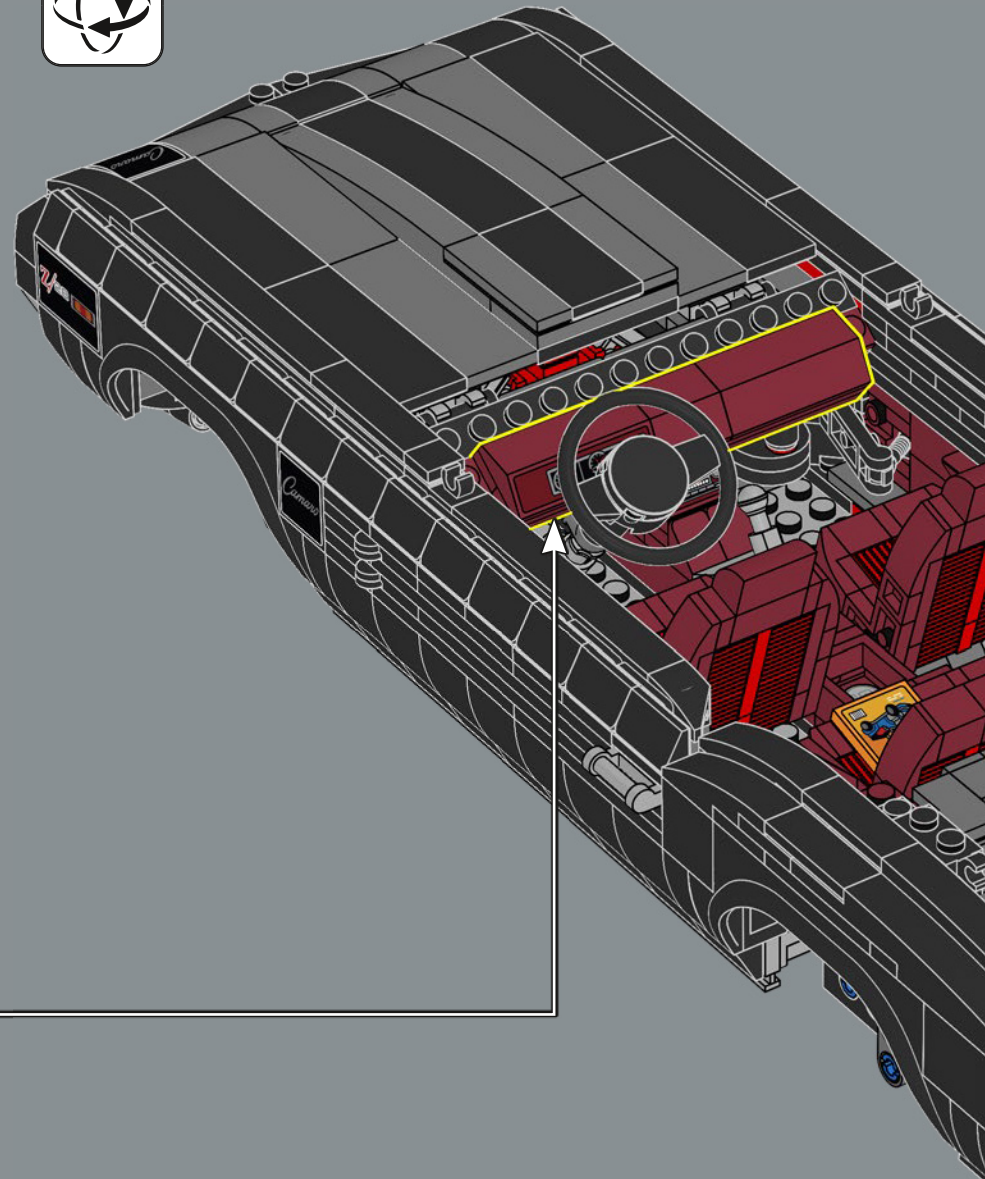
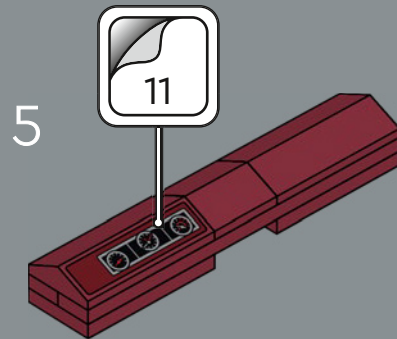
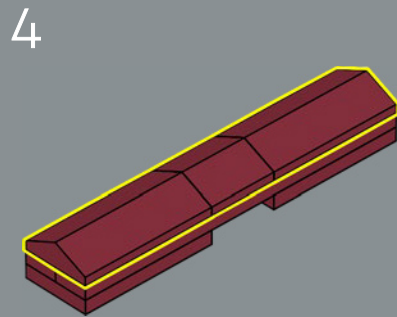
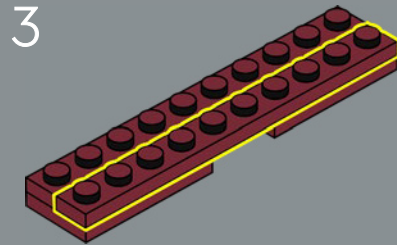
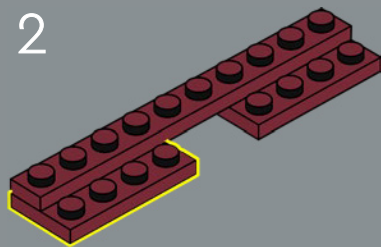
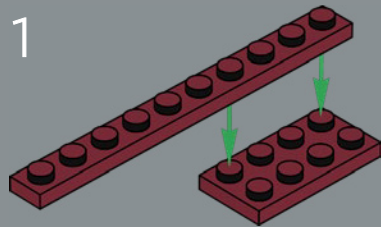

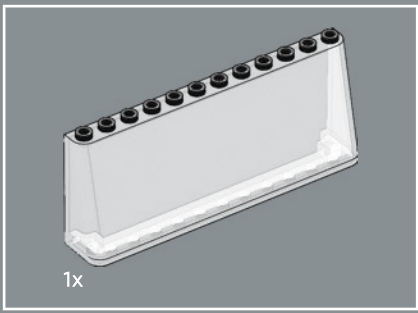

316

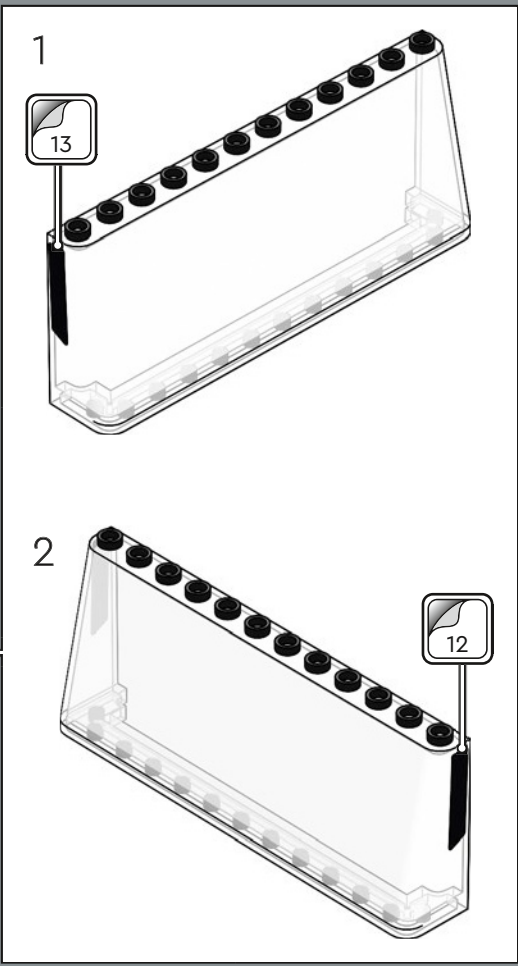
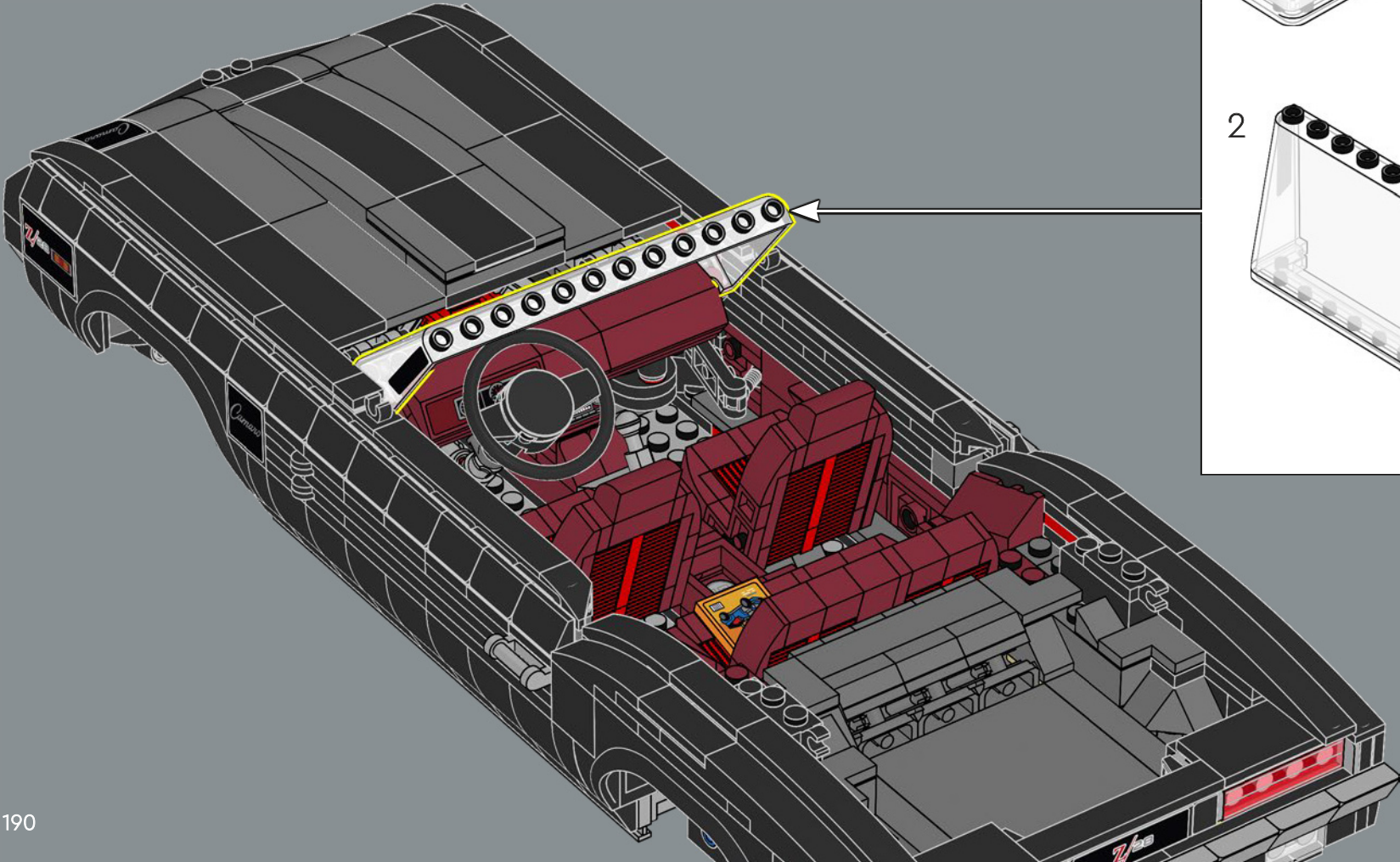

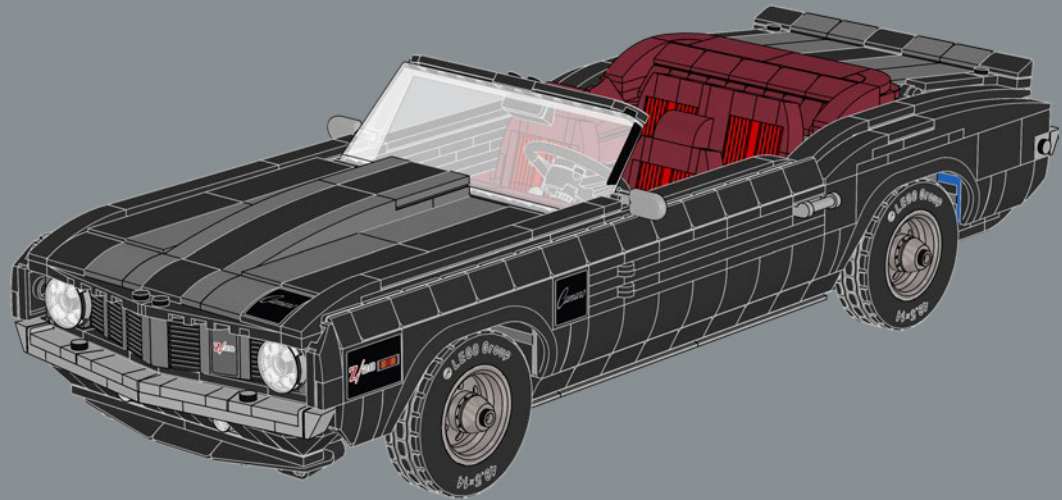
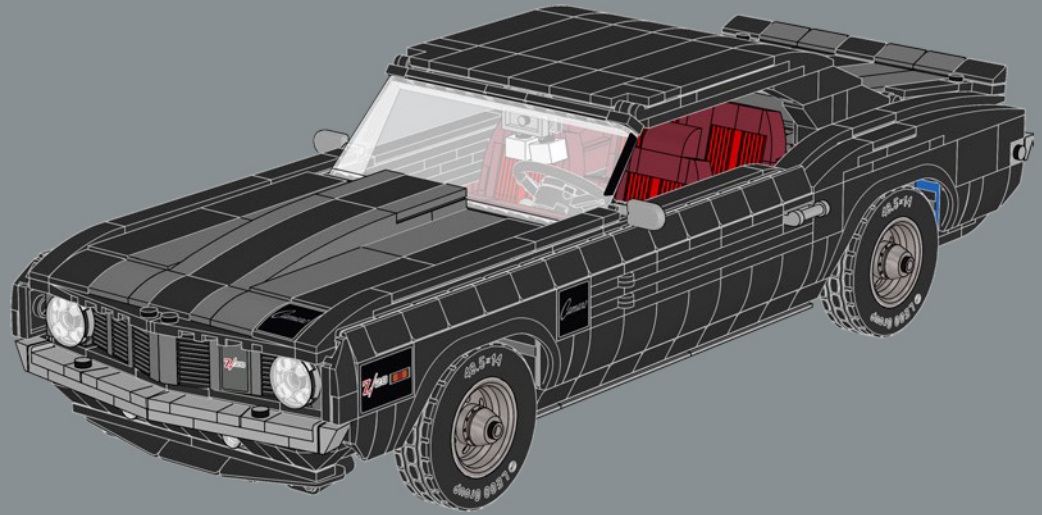

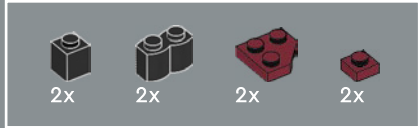
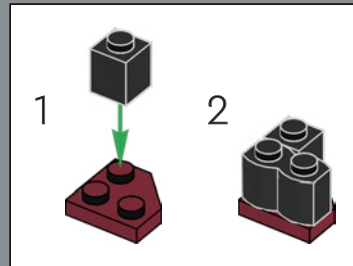

317

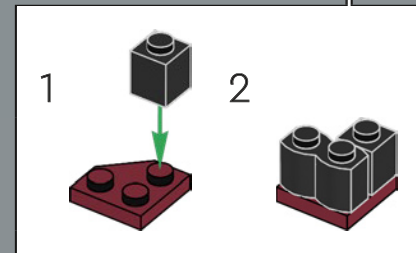
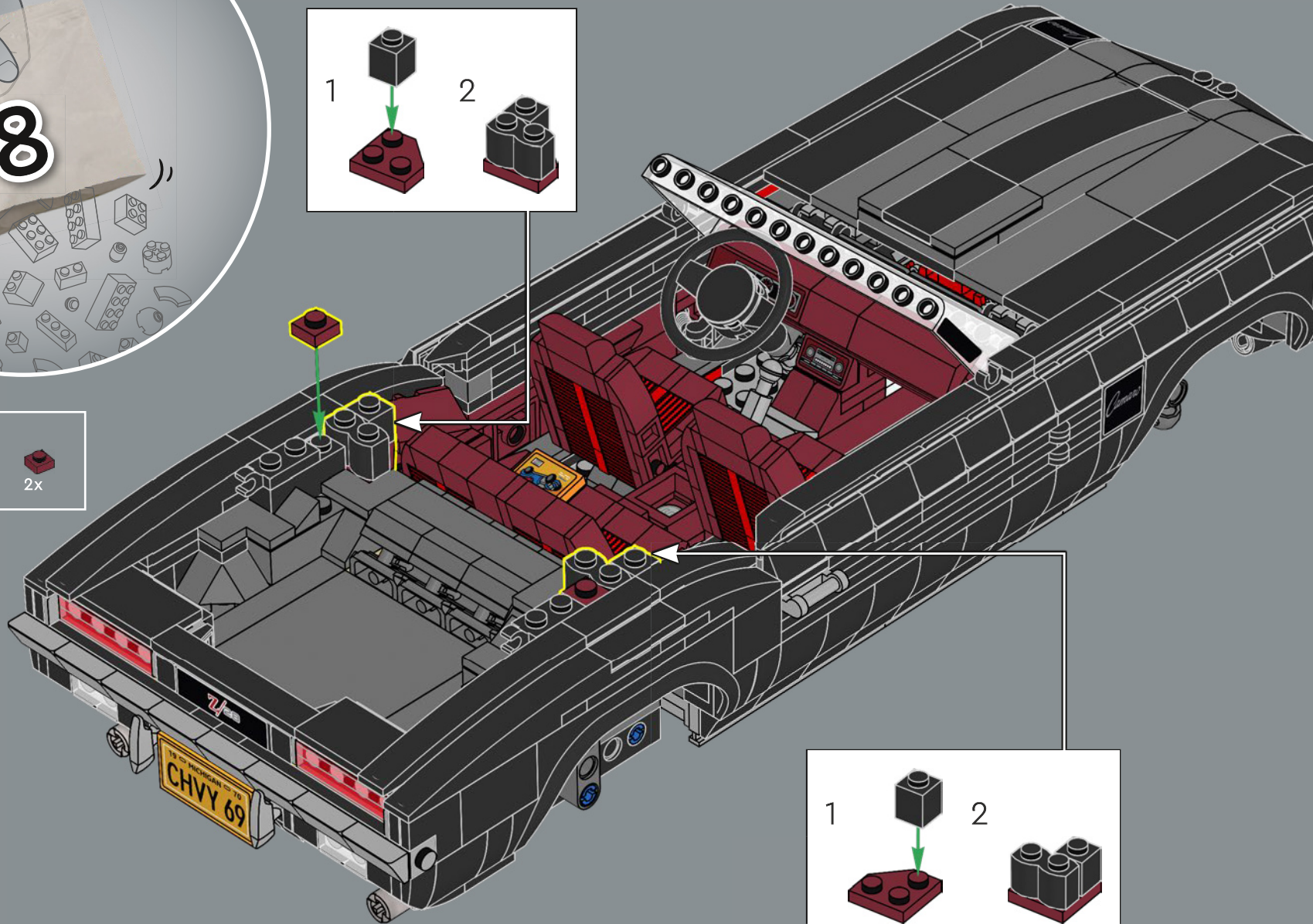

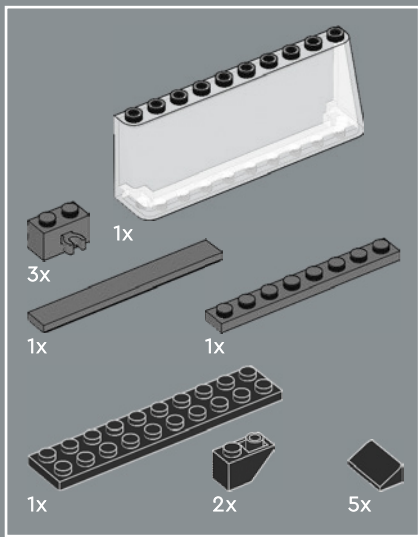

318

1

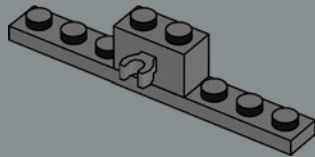

2

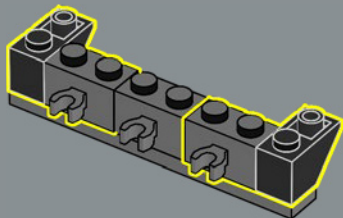

3

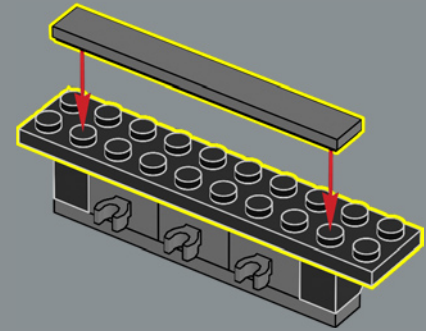

4

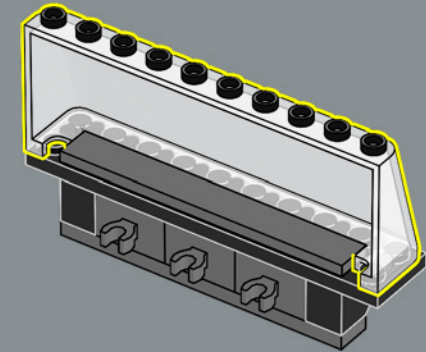

5

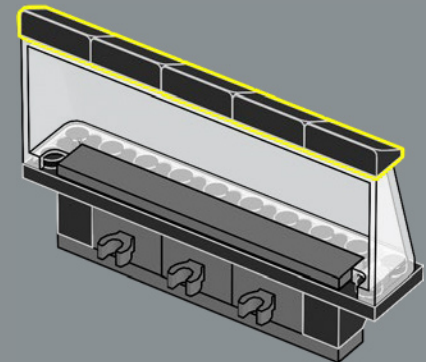

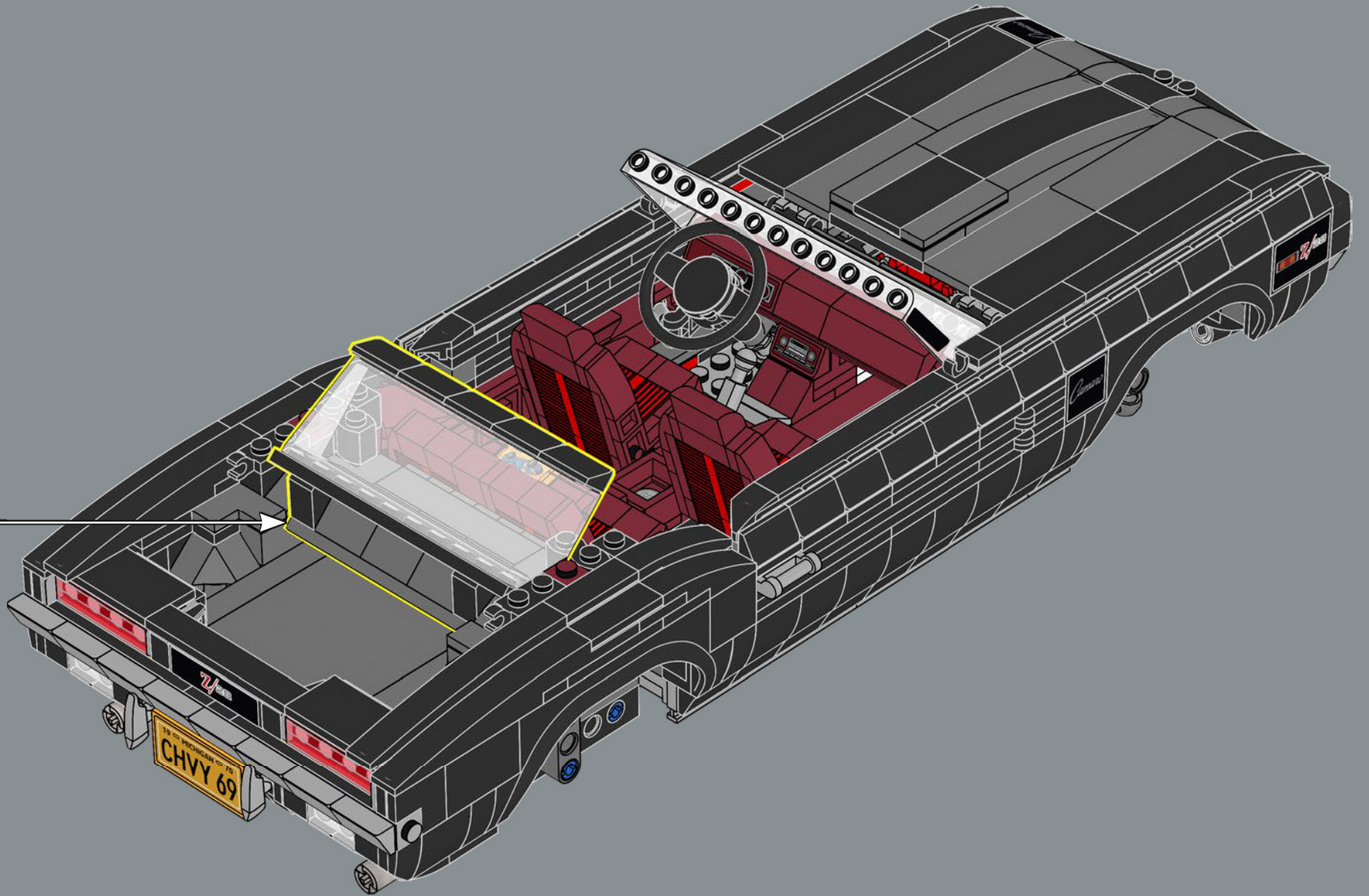

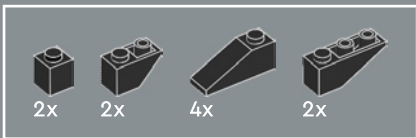

319

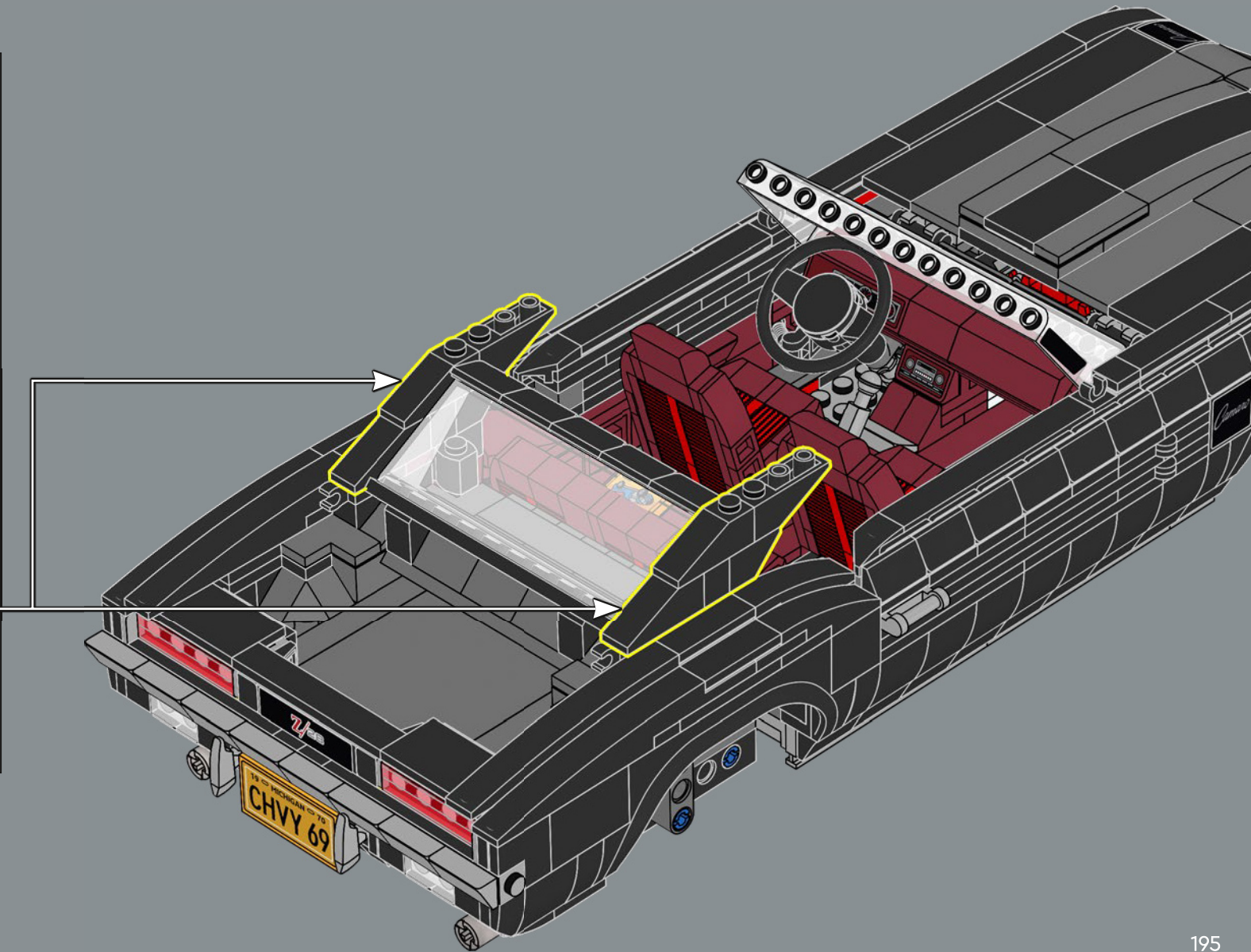
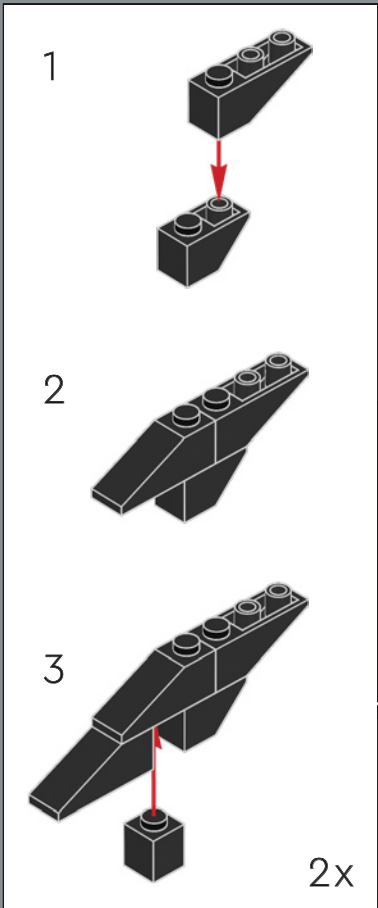

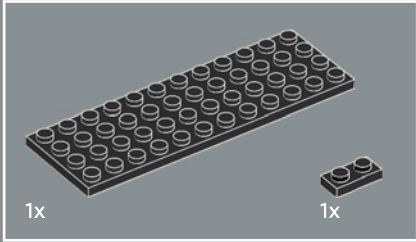
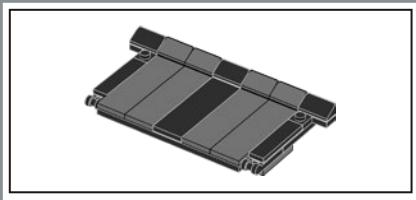

320

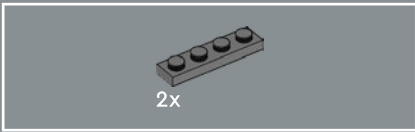
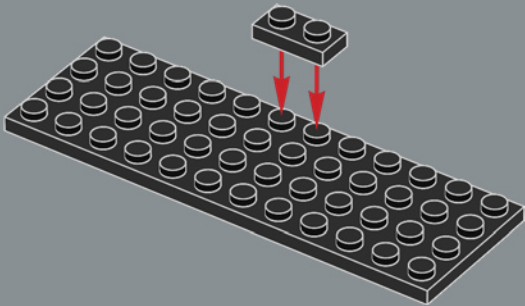

321

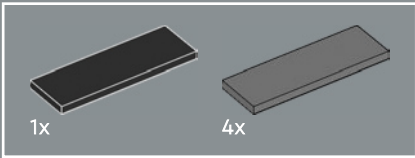
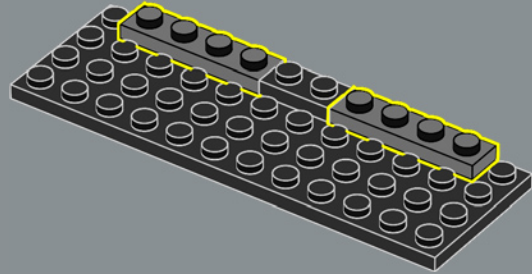

322

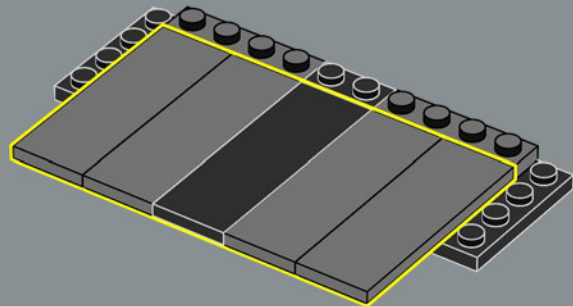

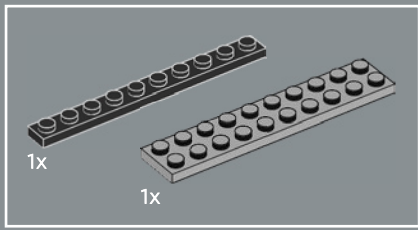

323

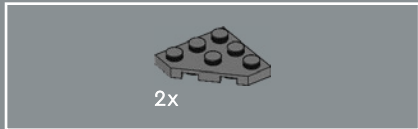
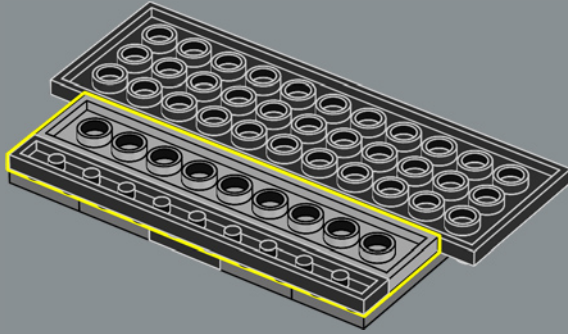

324

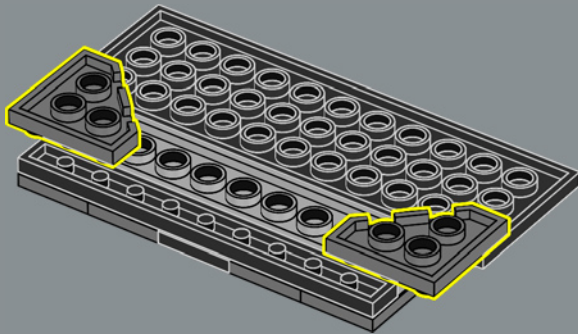

325

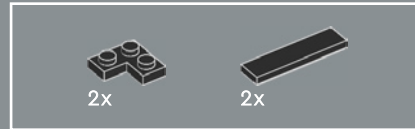
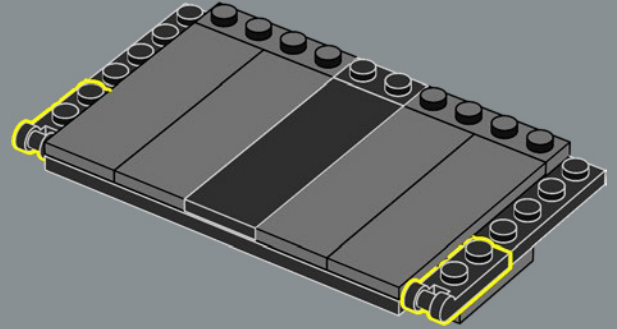

326

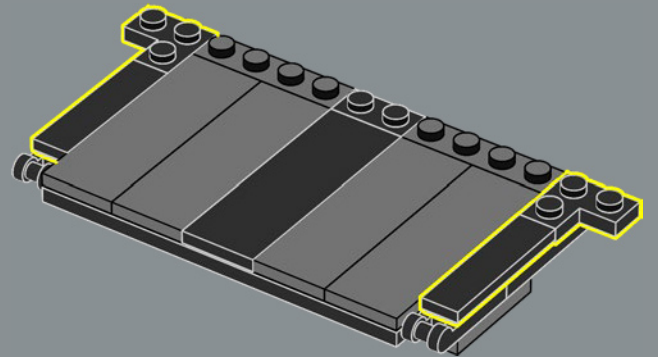

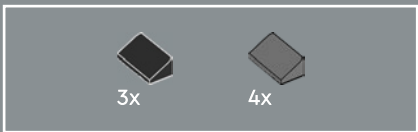

327

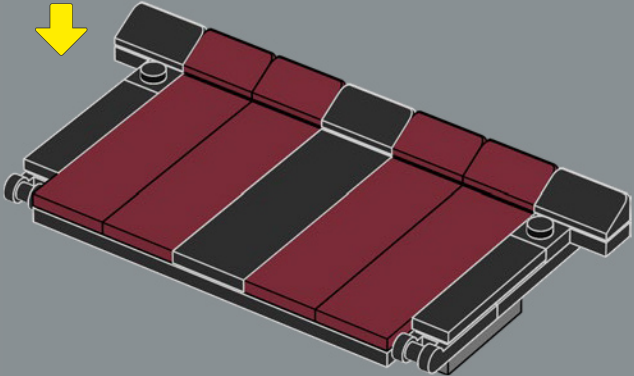
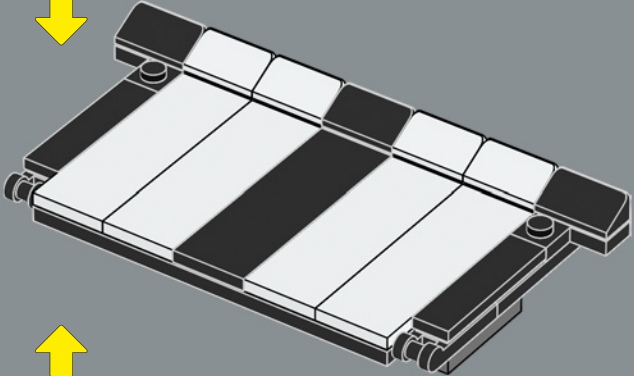
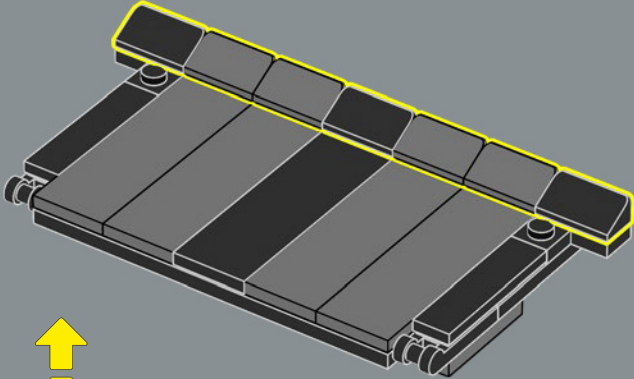

328

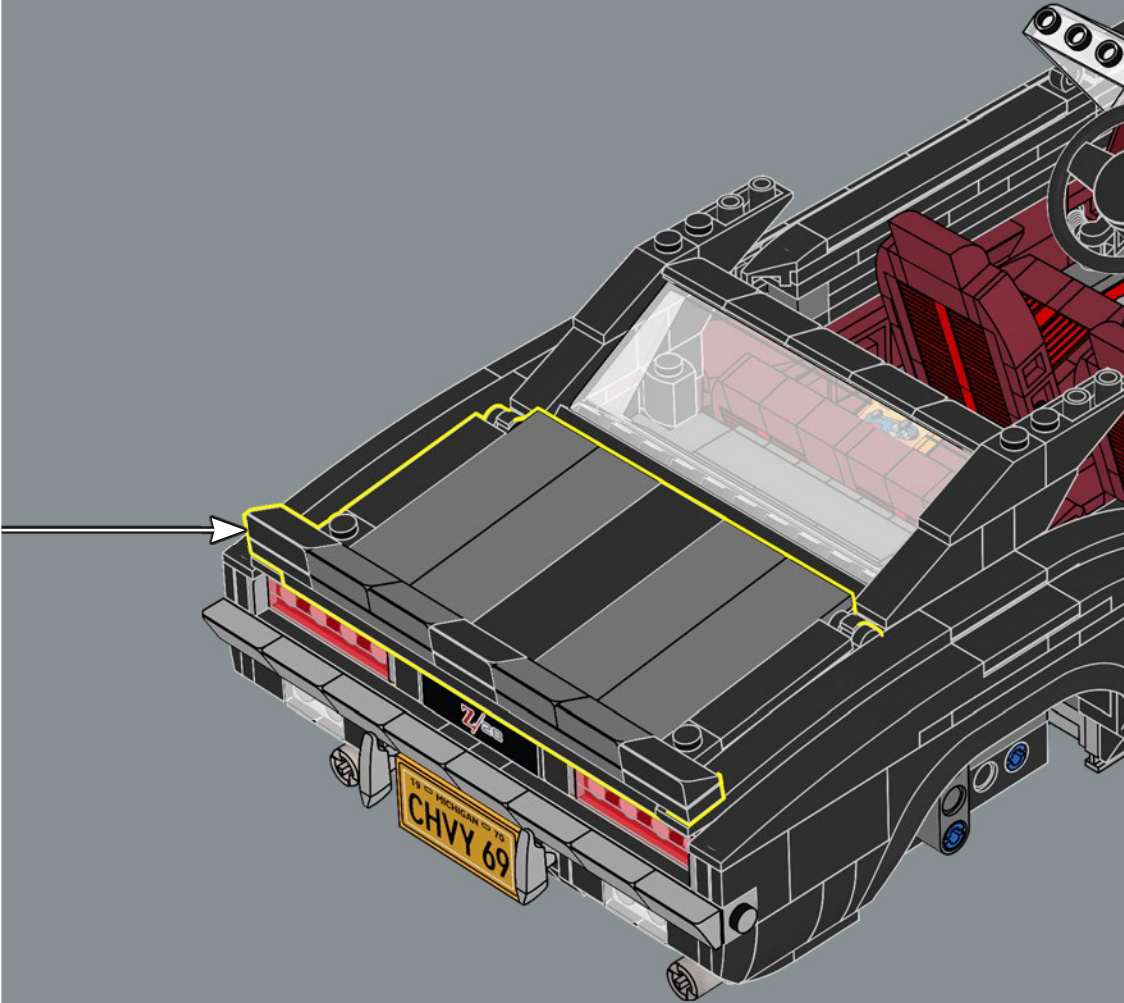

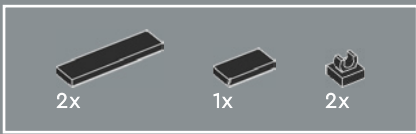

329

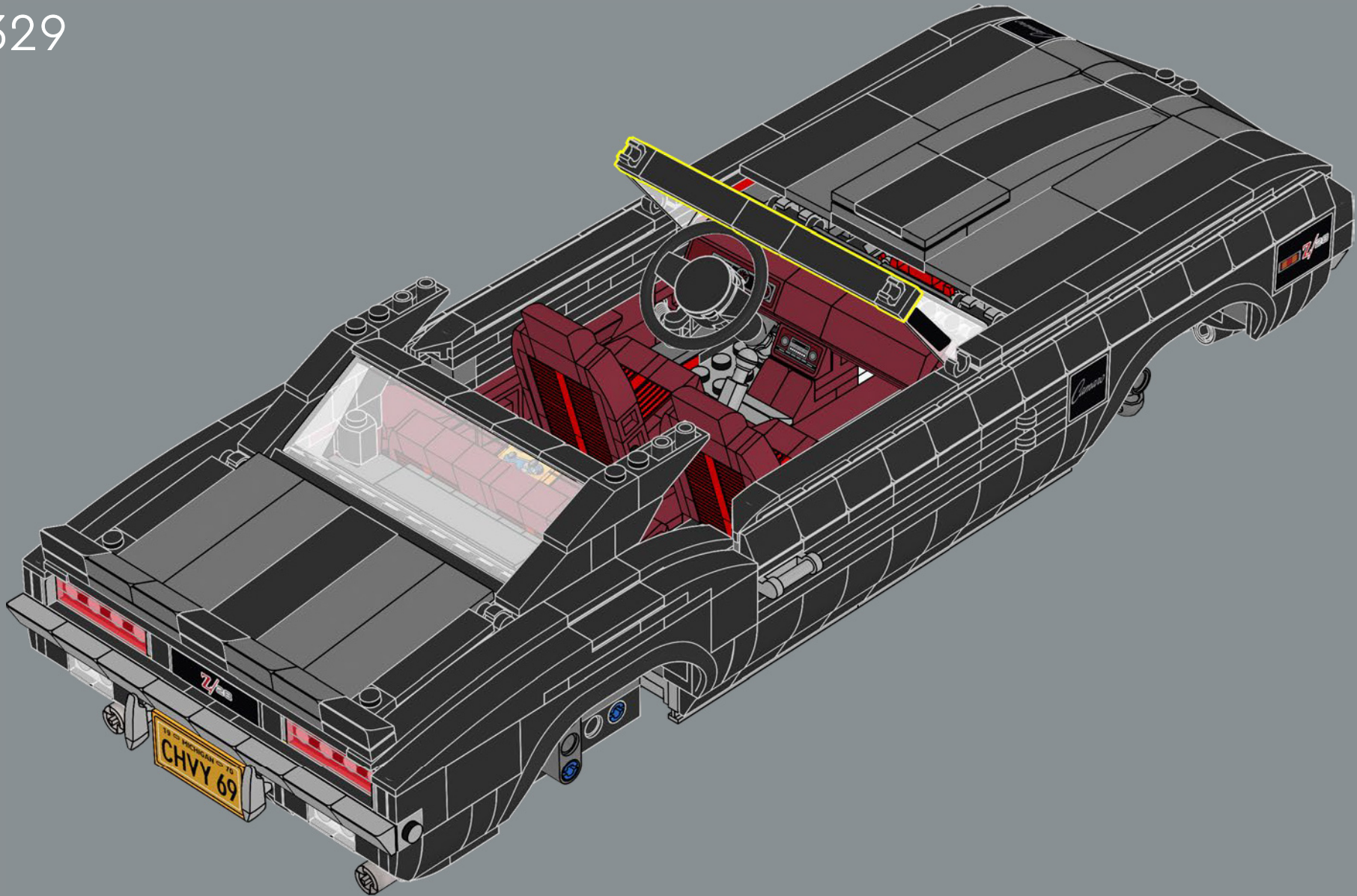

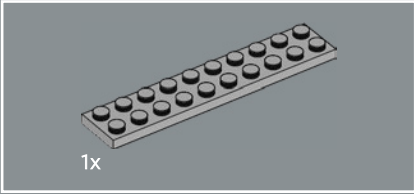
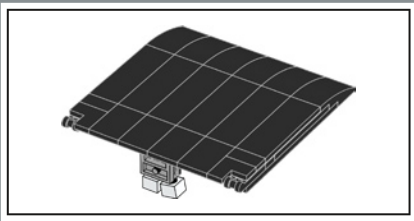

330

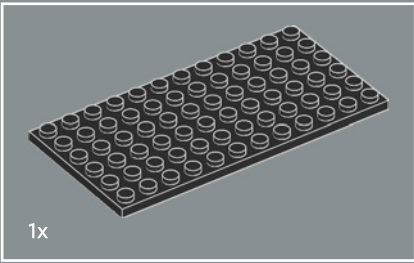
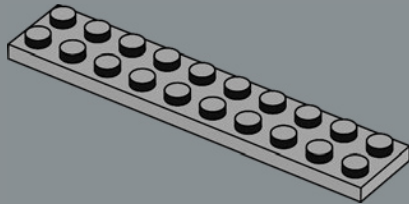

331

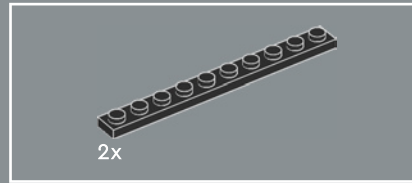
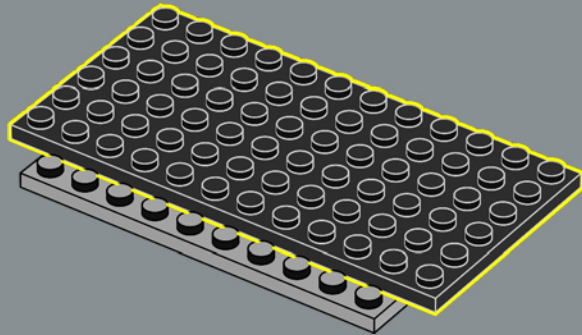

2x

332

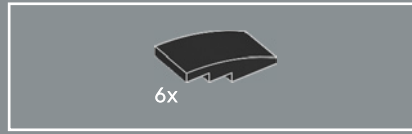
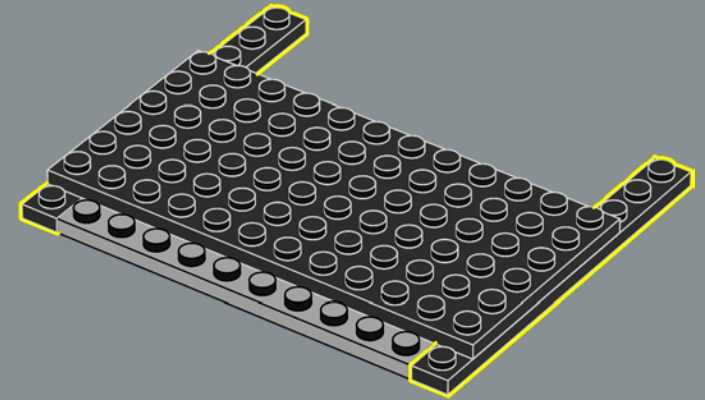

6x

333

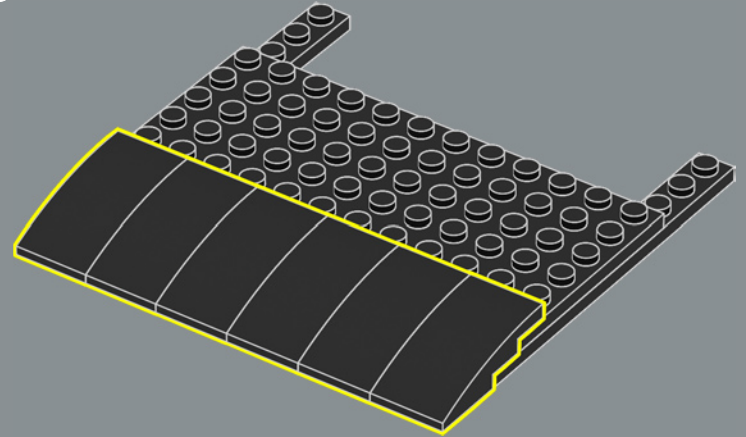

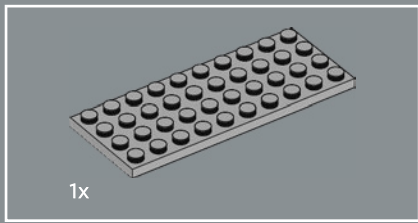

334

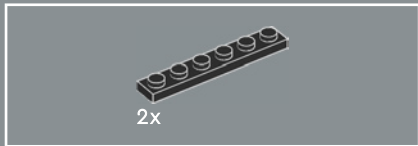
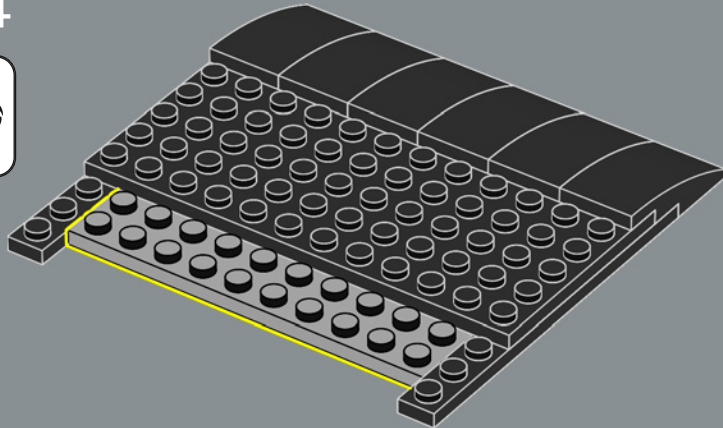

335

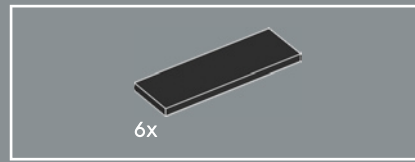
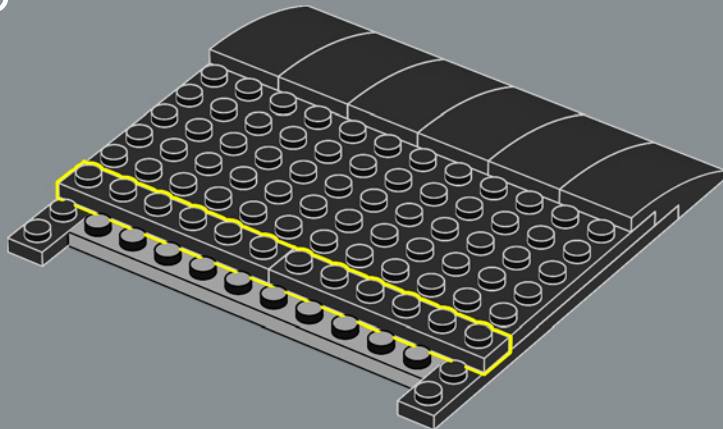

336

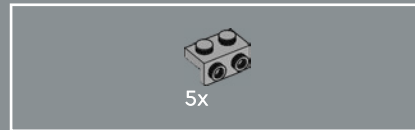
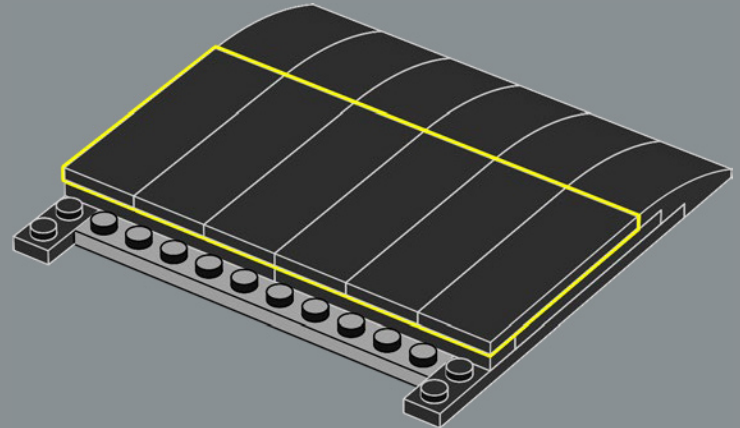

337

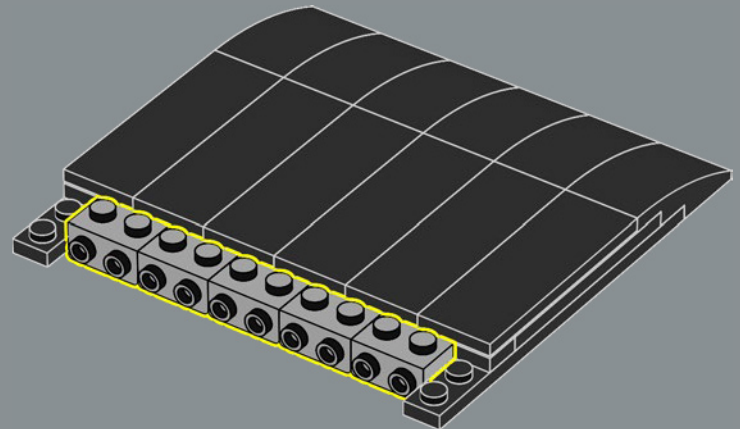

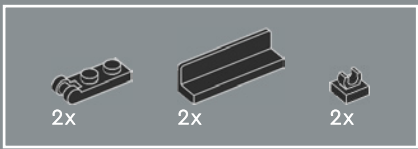

338

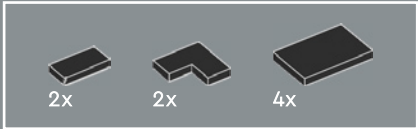
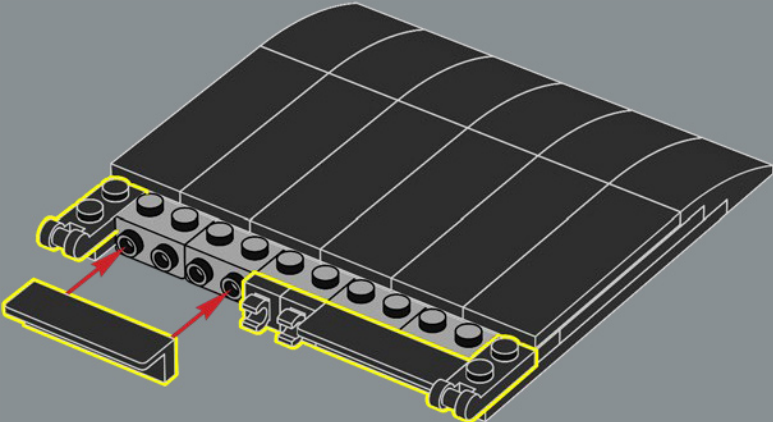

339

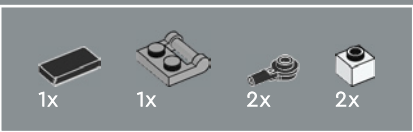
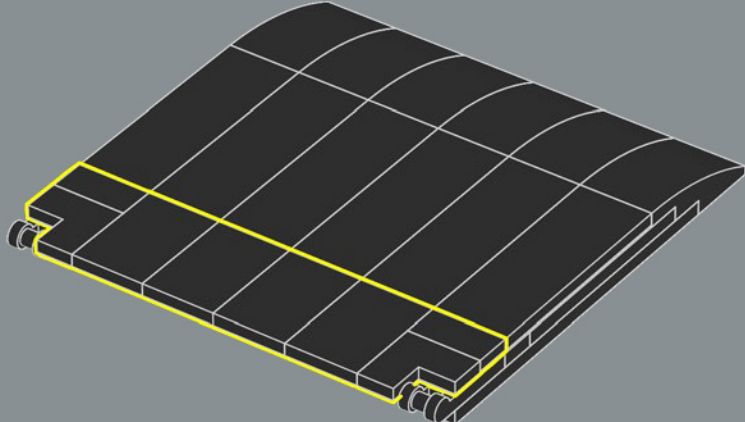

340

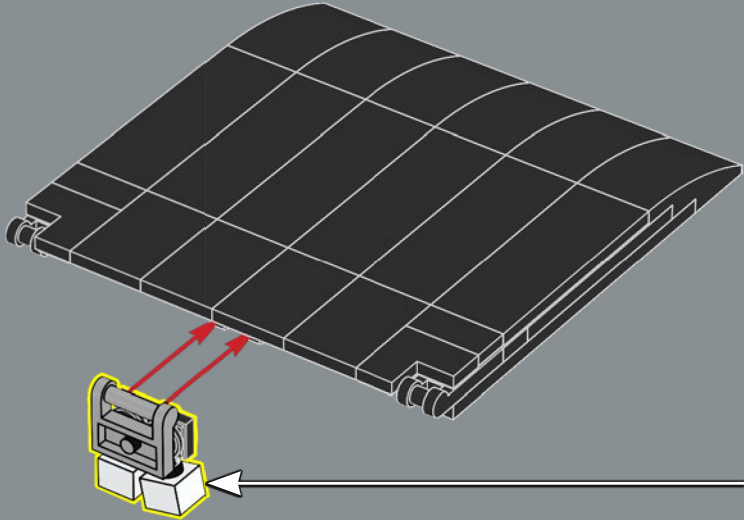
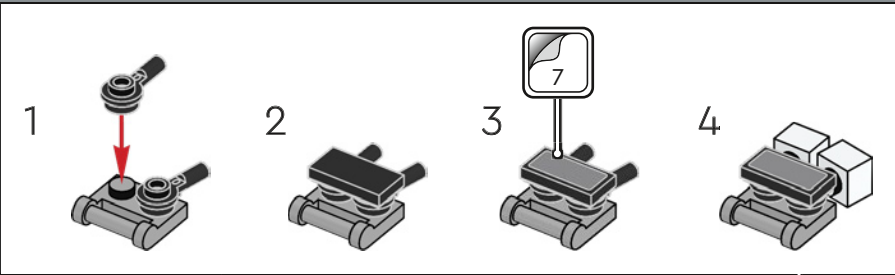

341

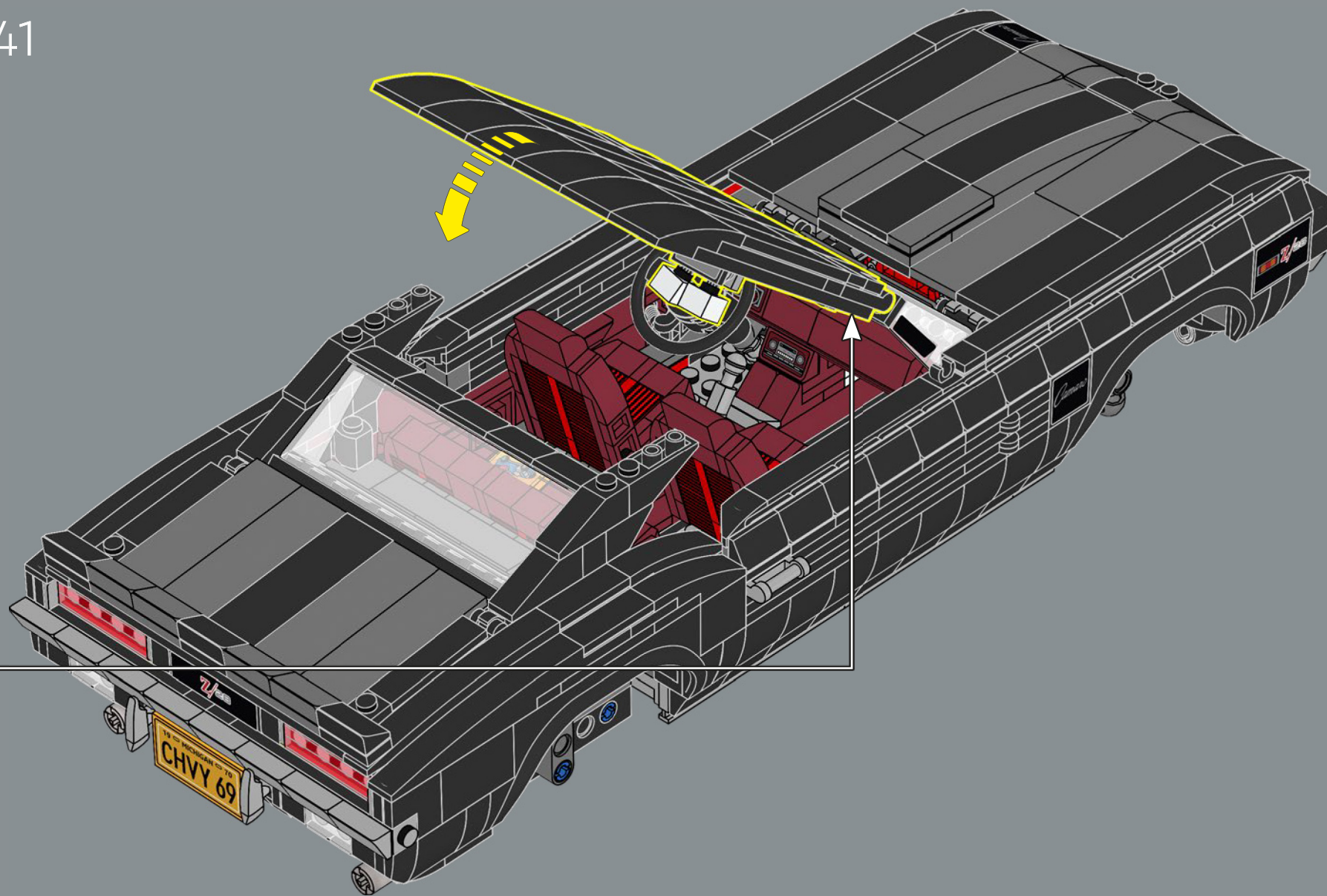

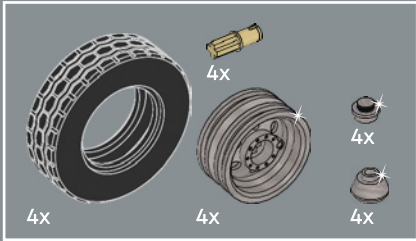
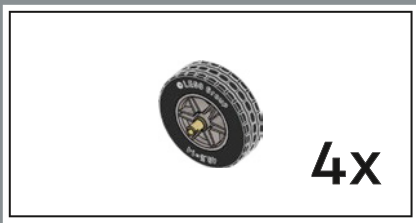

342

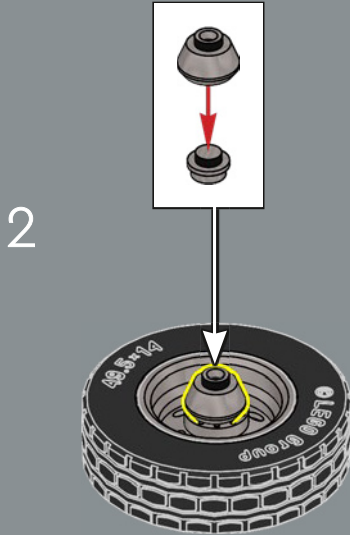
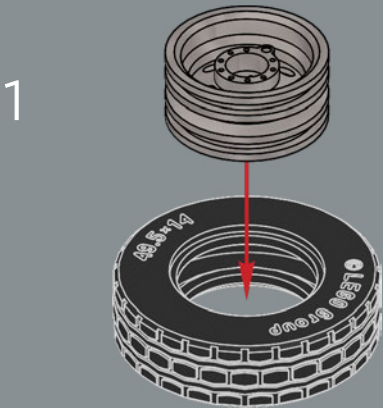

4x

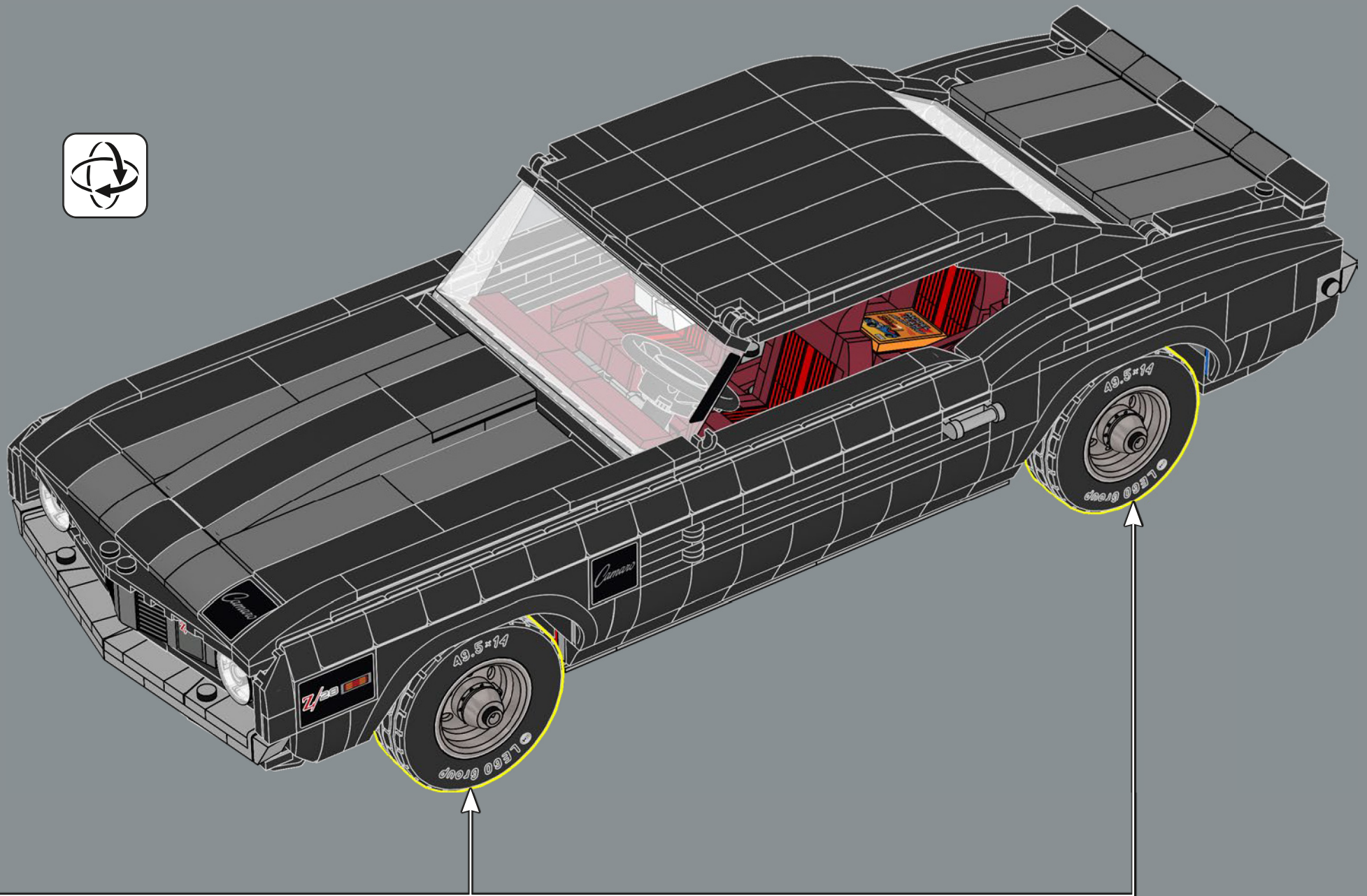



2x

343

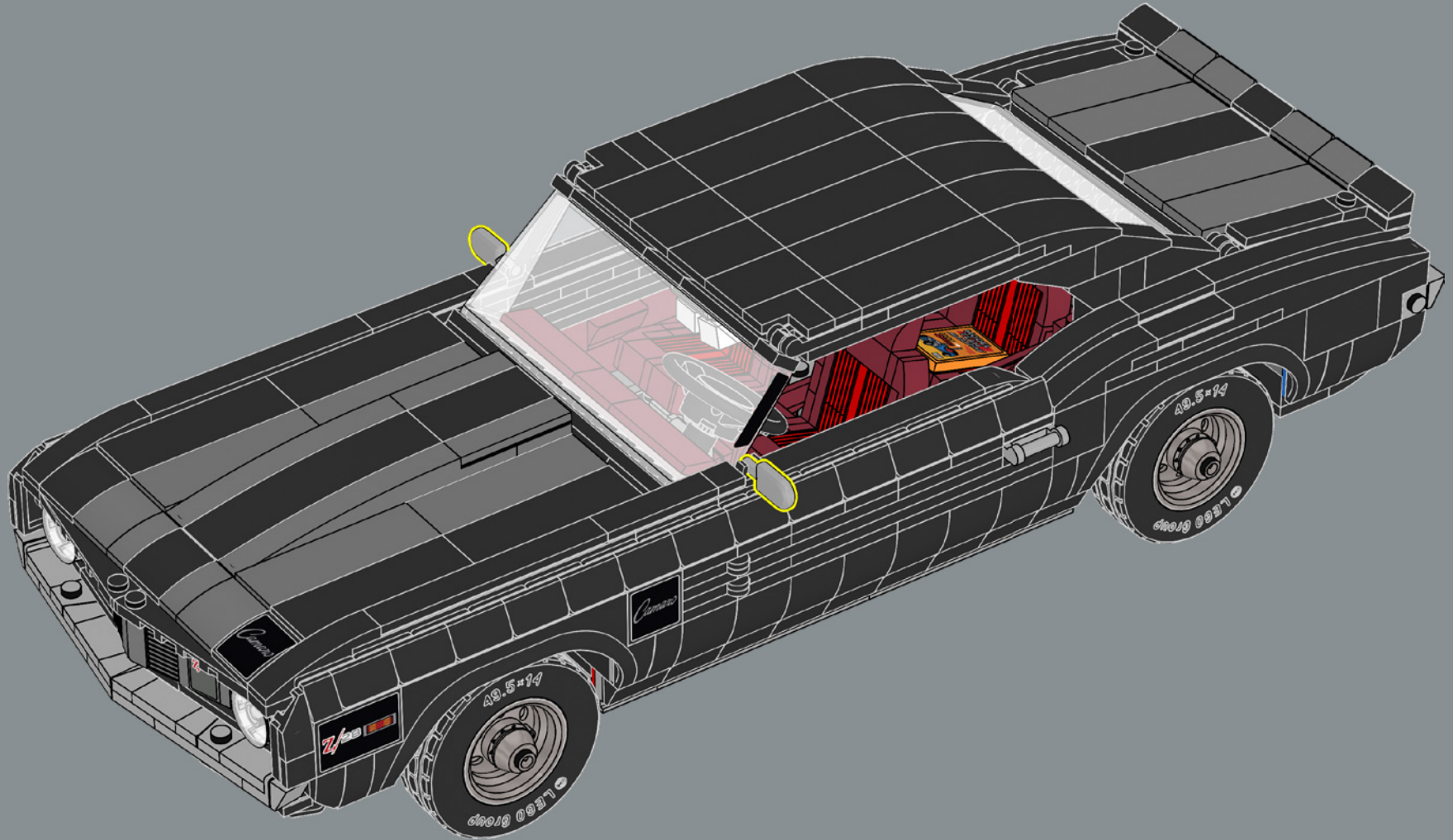

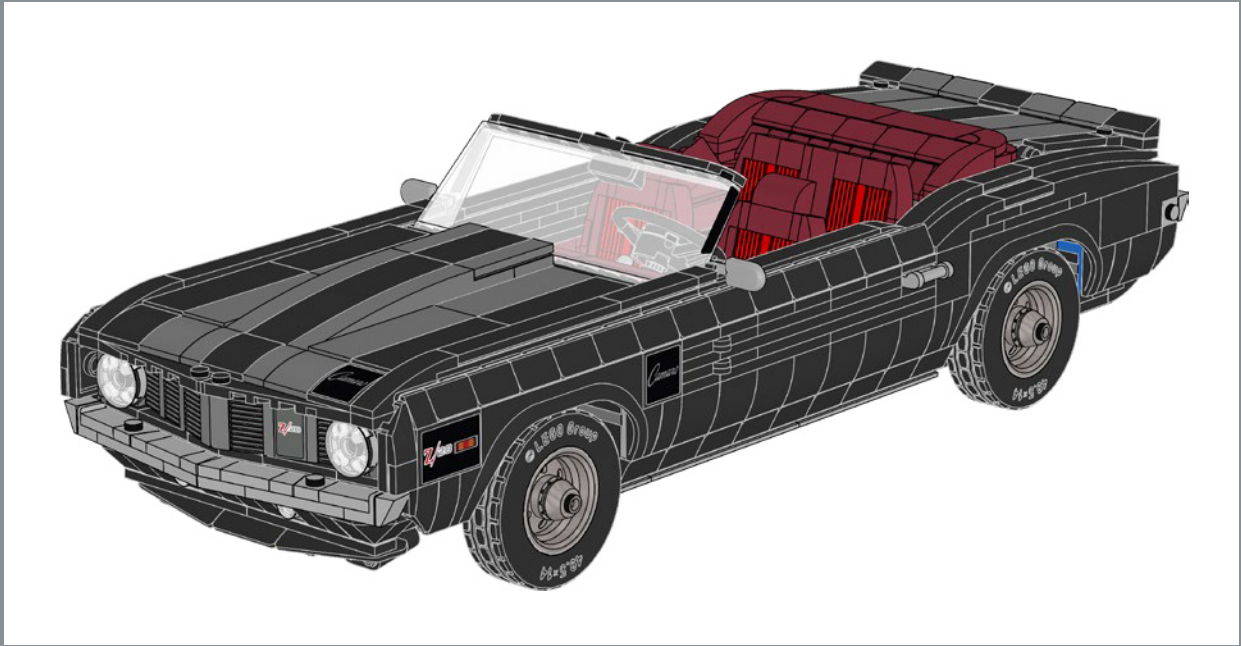

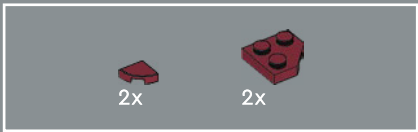

317

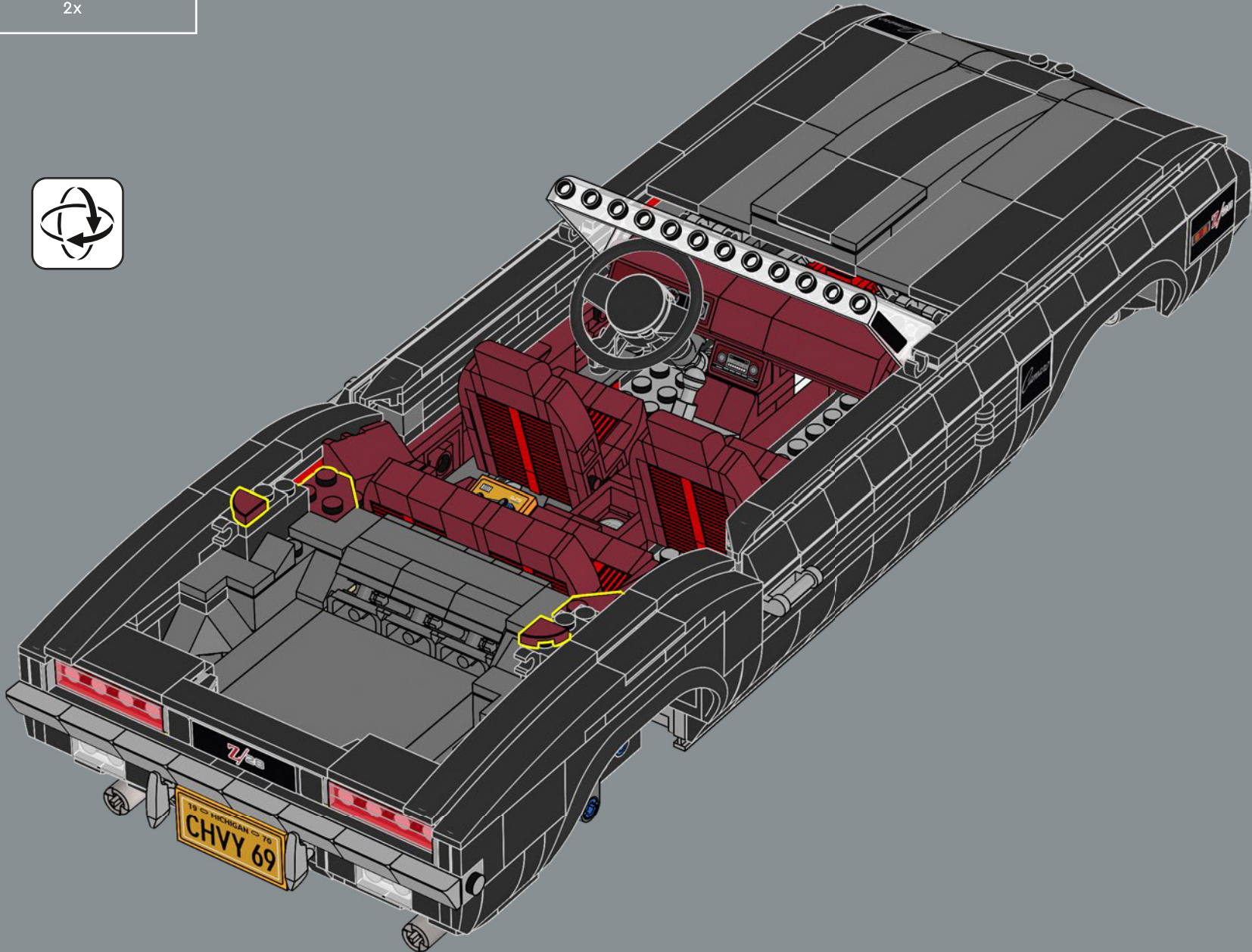

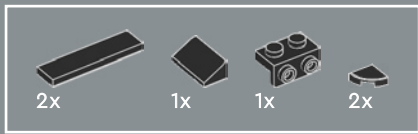

318

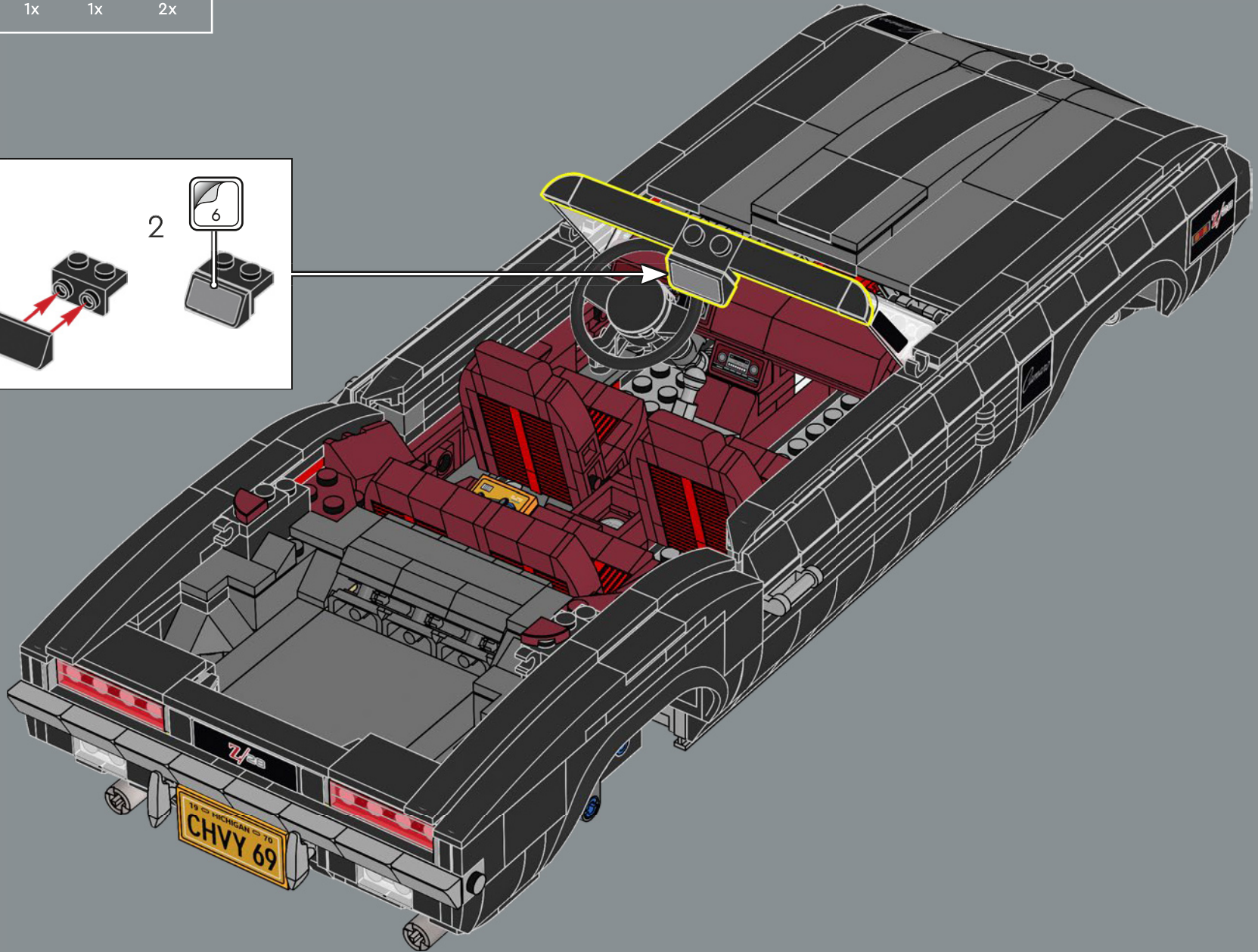
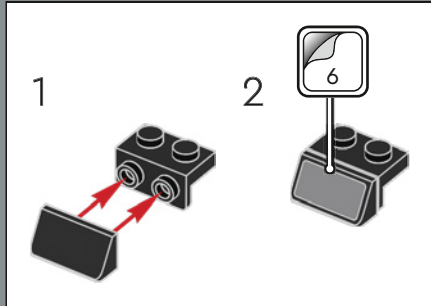

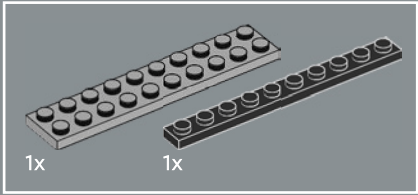

319

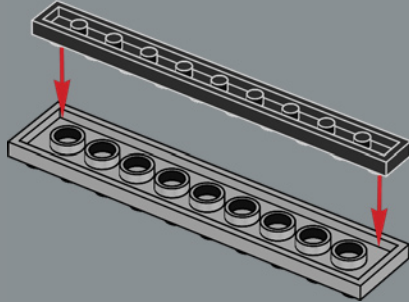

320

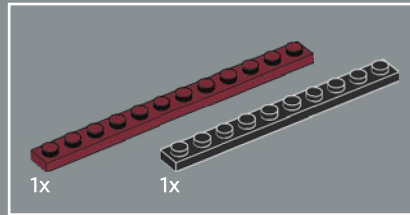
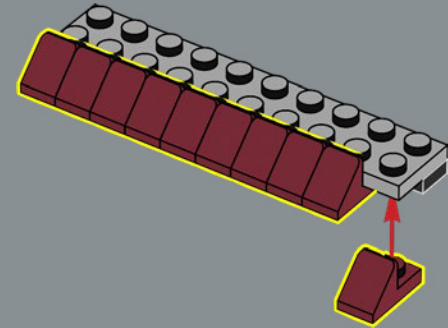

321

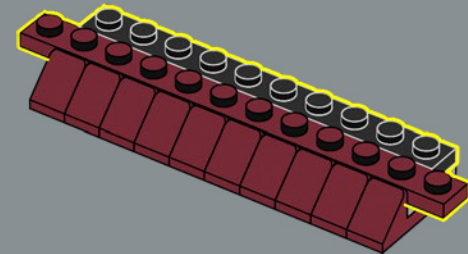

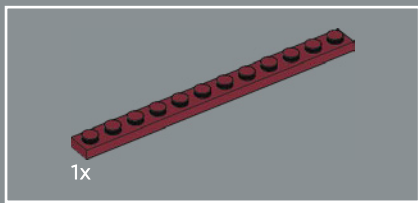

322

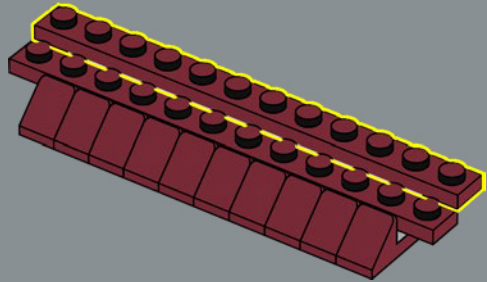

323

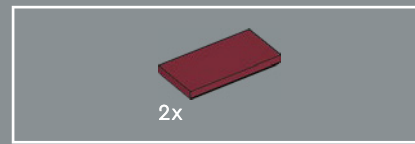
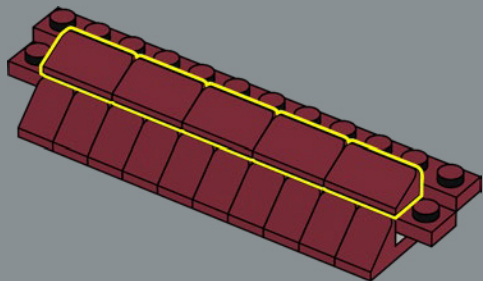

324

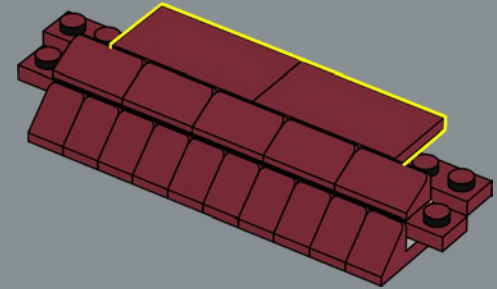

325

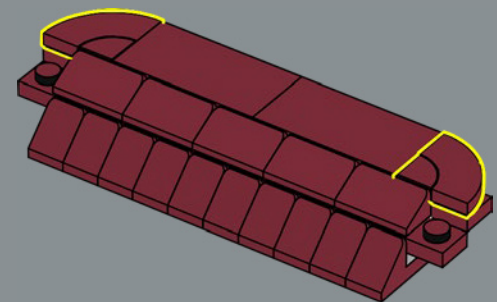

326

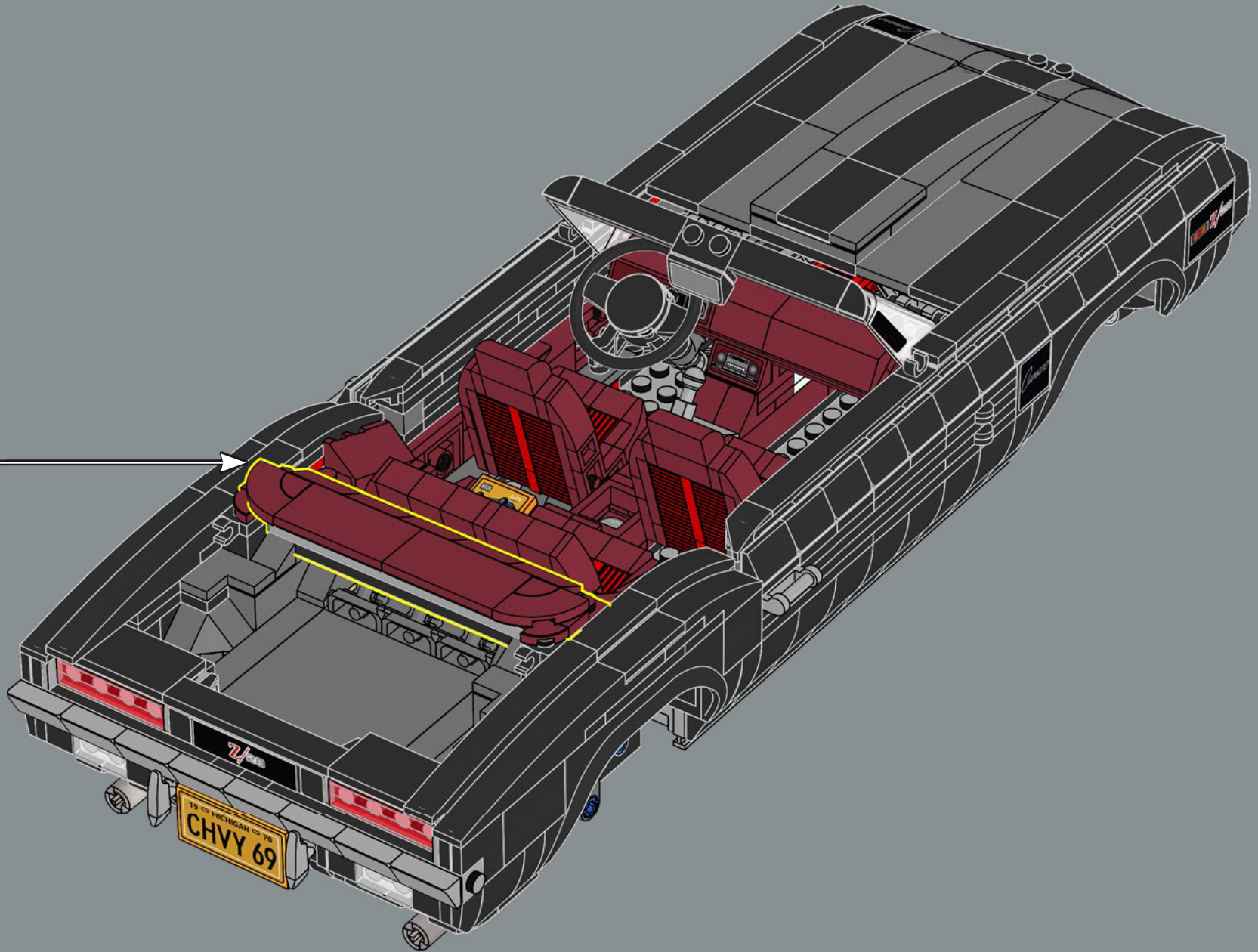

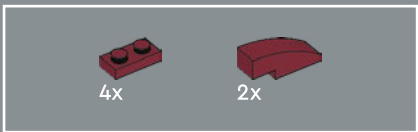

327

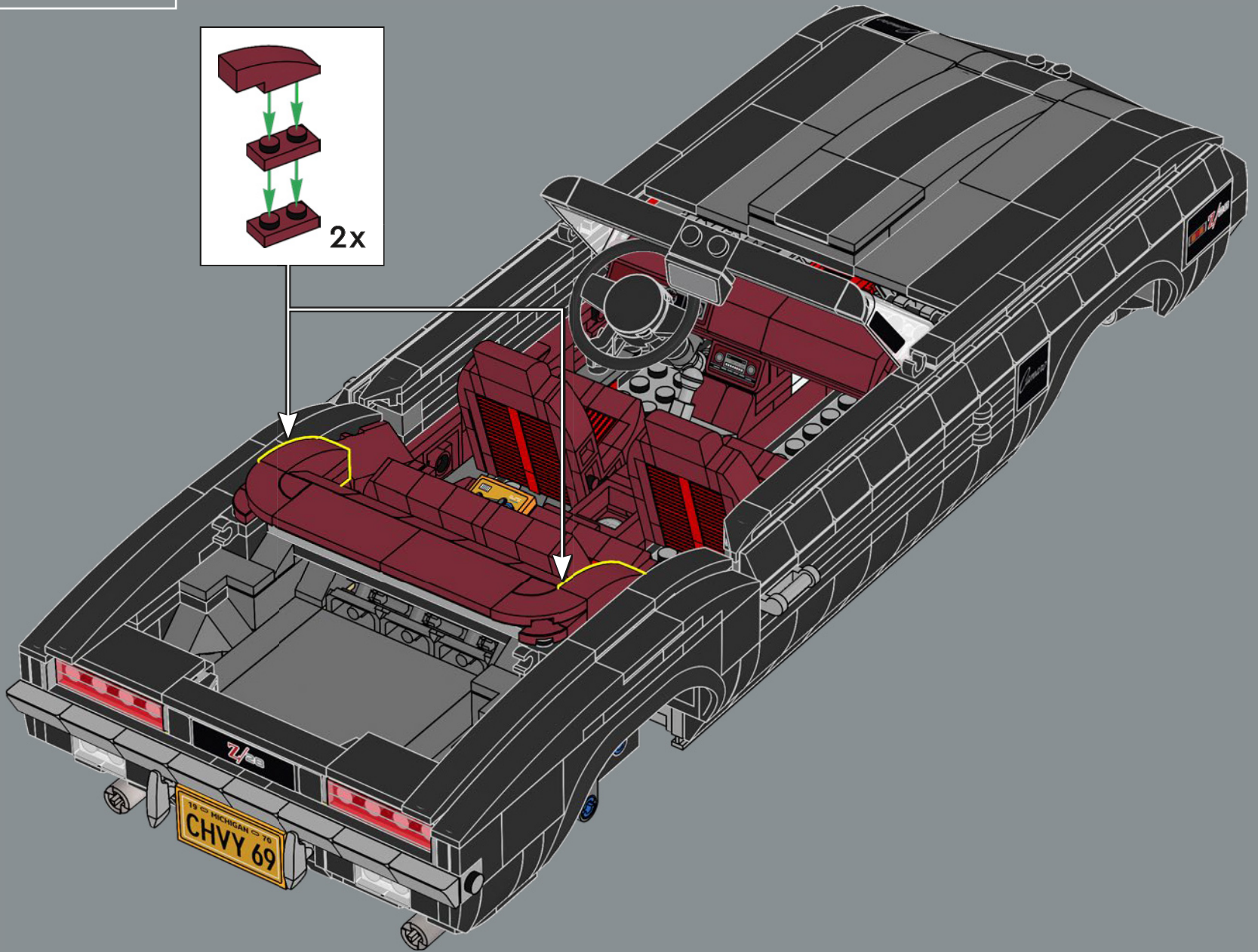
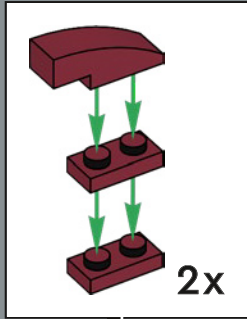

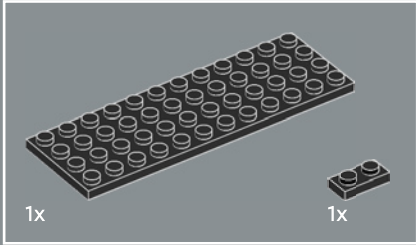
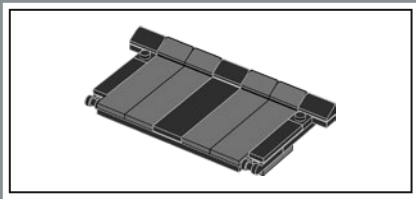

328

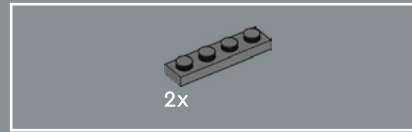
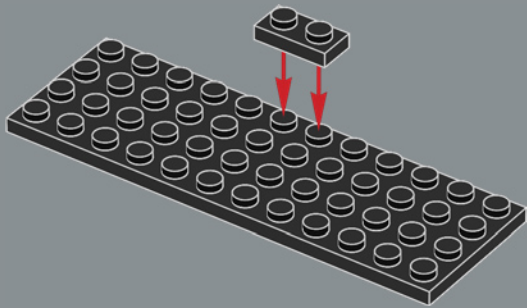

329

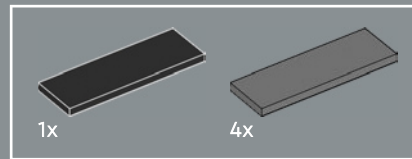
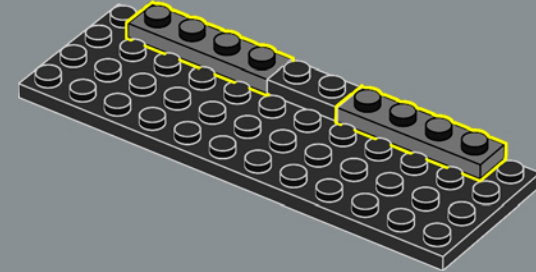

330

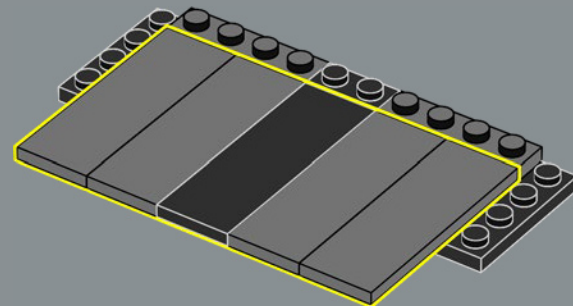

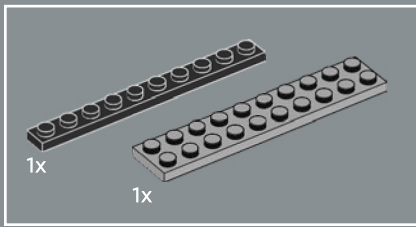

331

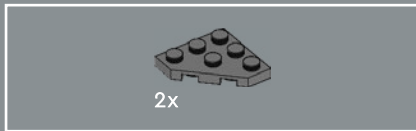
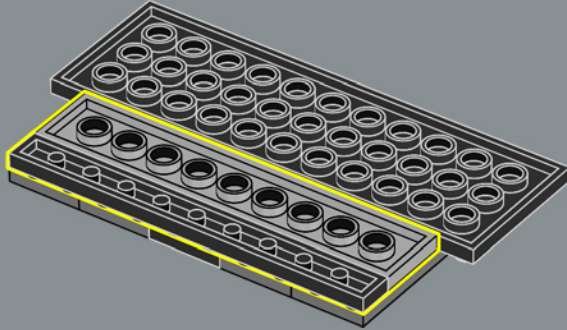

332

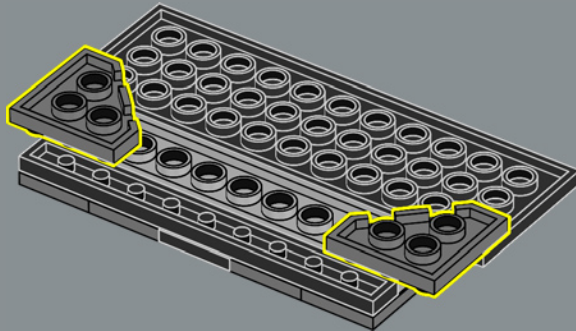

333

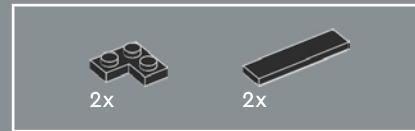
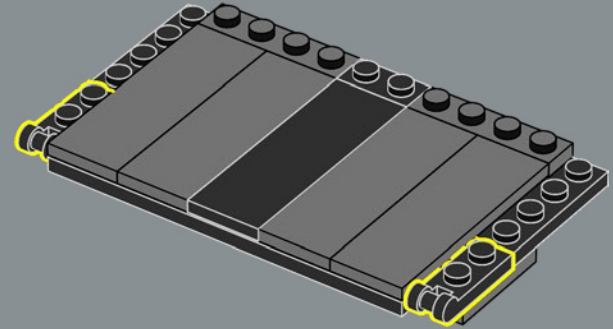

334

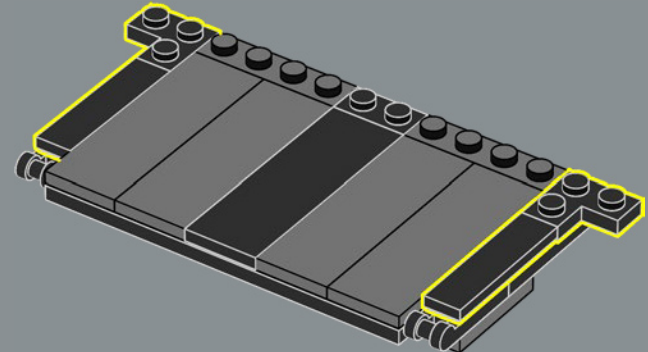

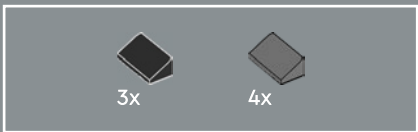

335

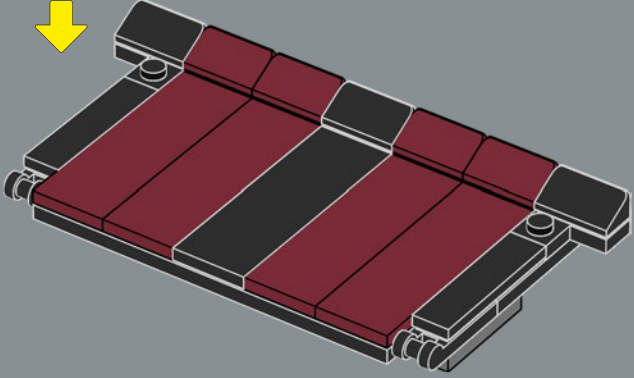
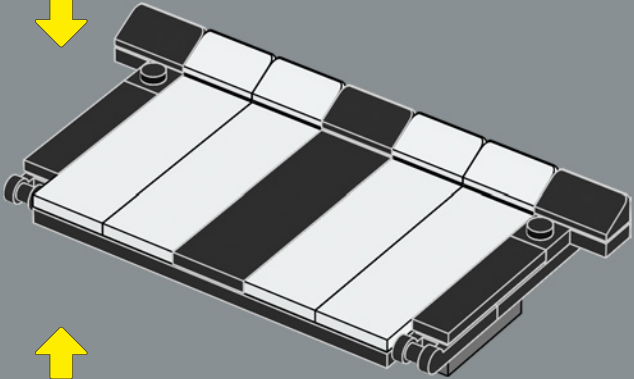
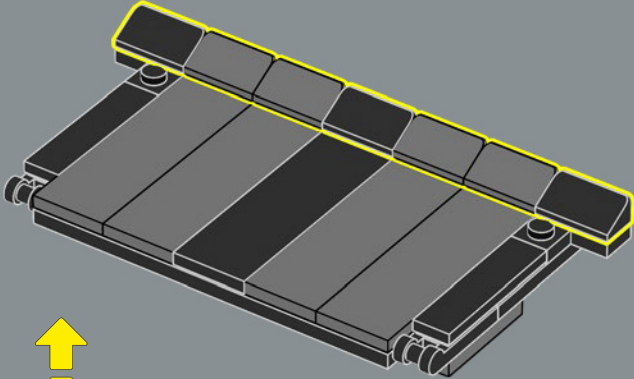

336

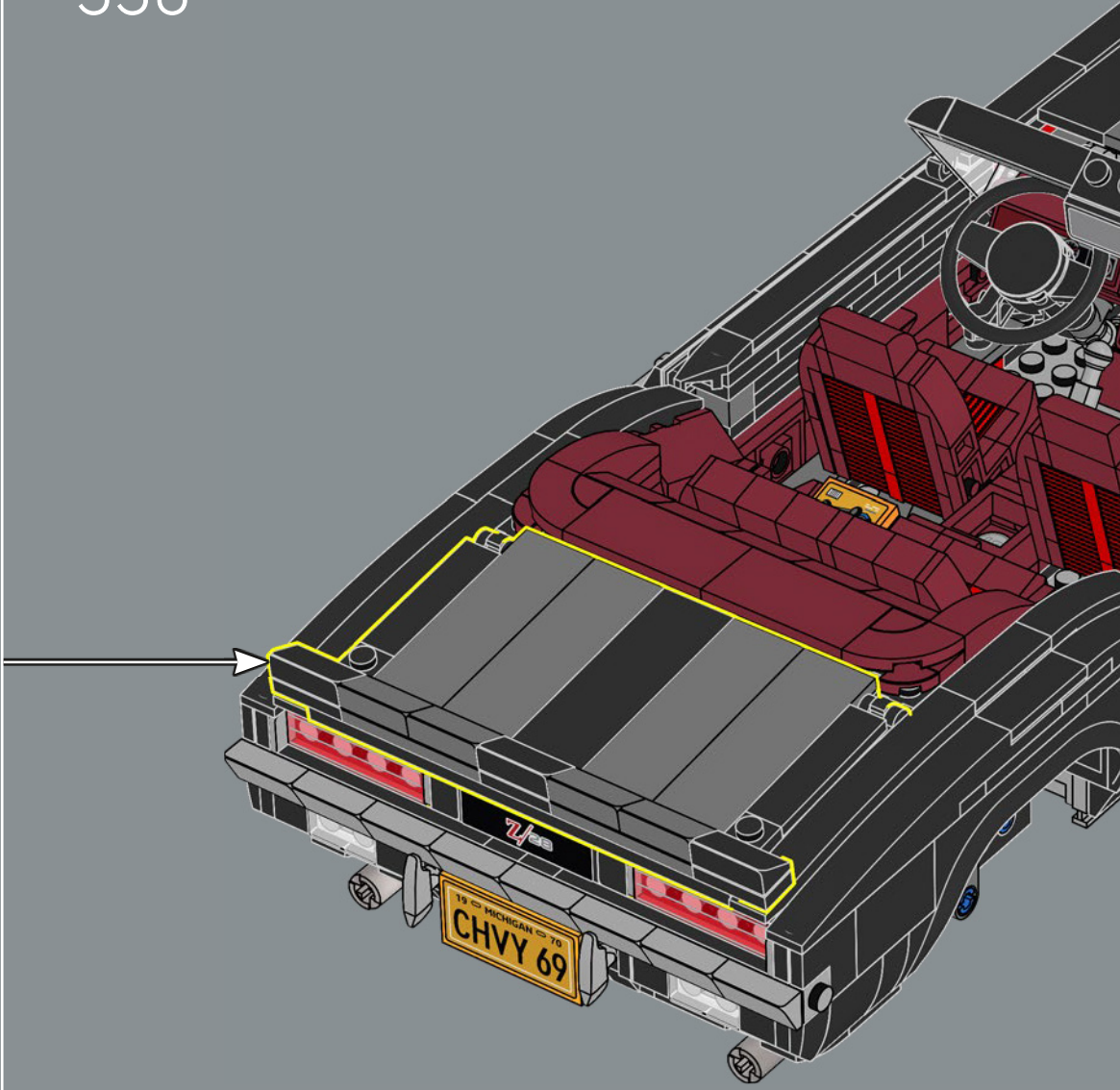

La réplica de edición limitada del Camaro Z11 que se usó como coche de seguridad en las 500 Millas de Indianápolis de 1969 sigue siendo una de las variantes más codiciadas del Camaro.

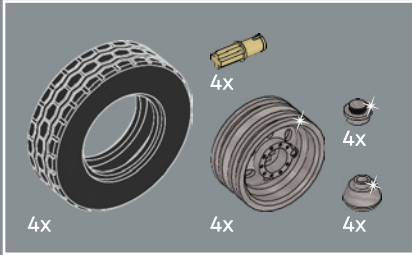
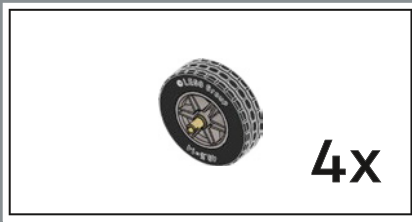

337

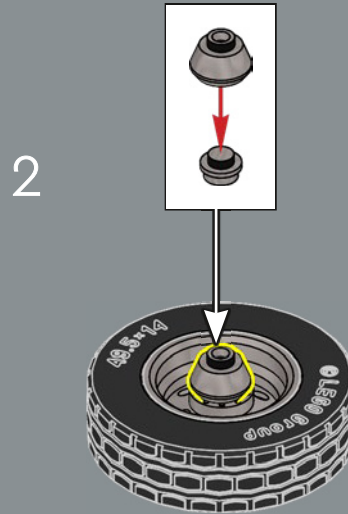
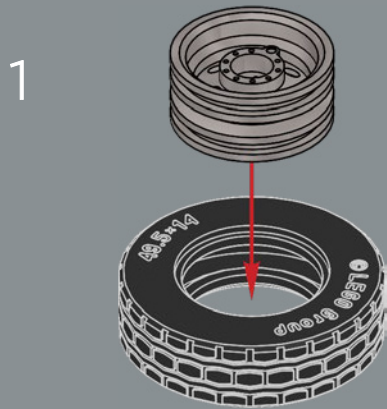

4x

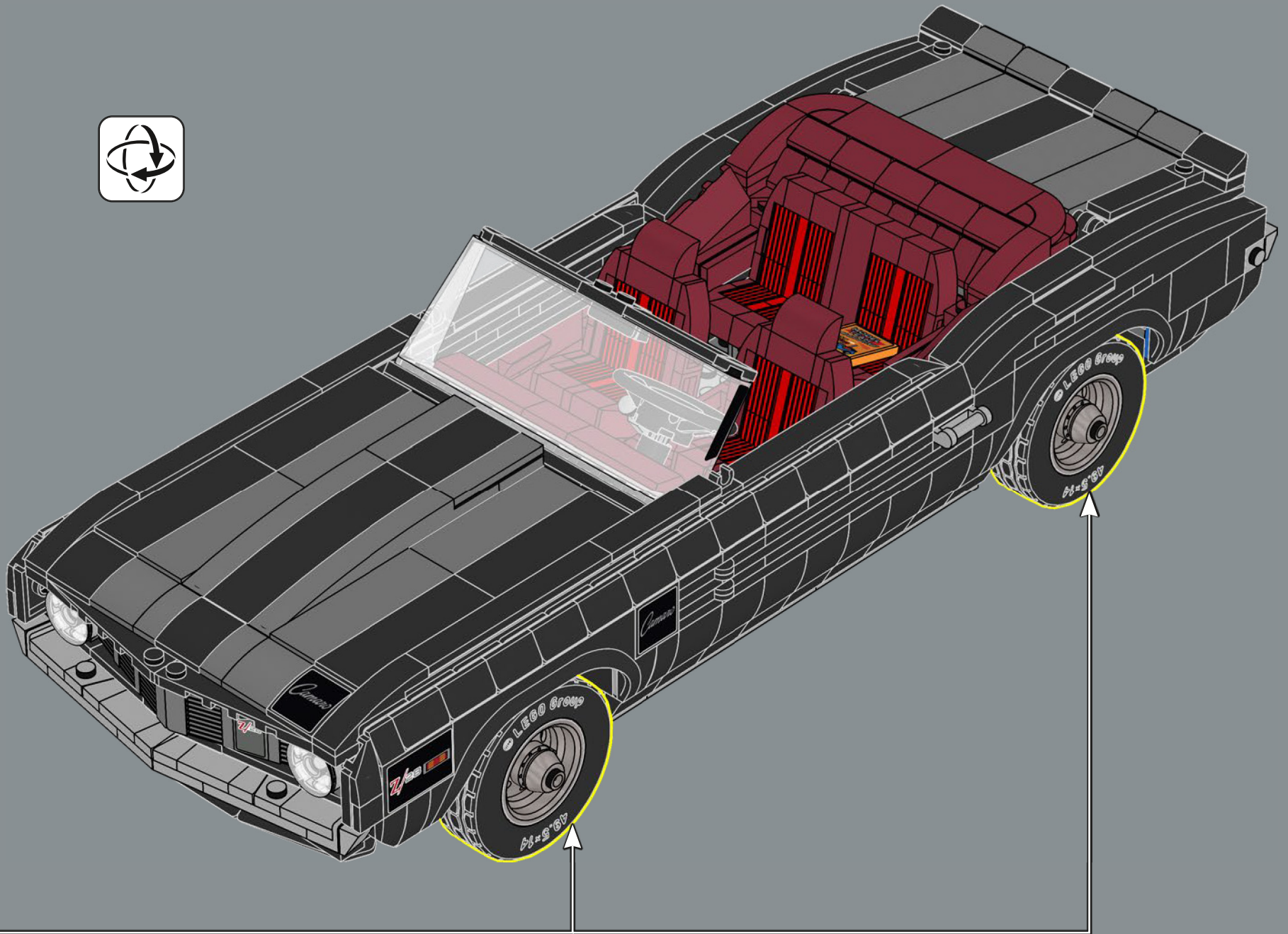



338

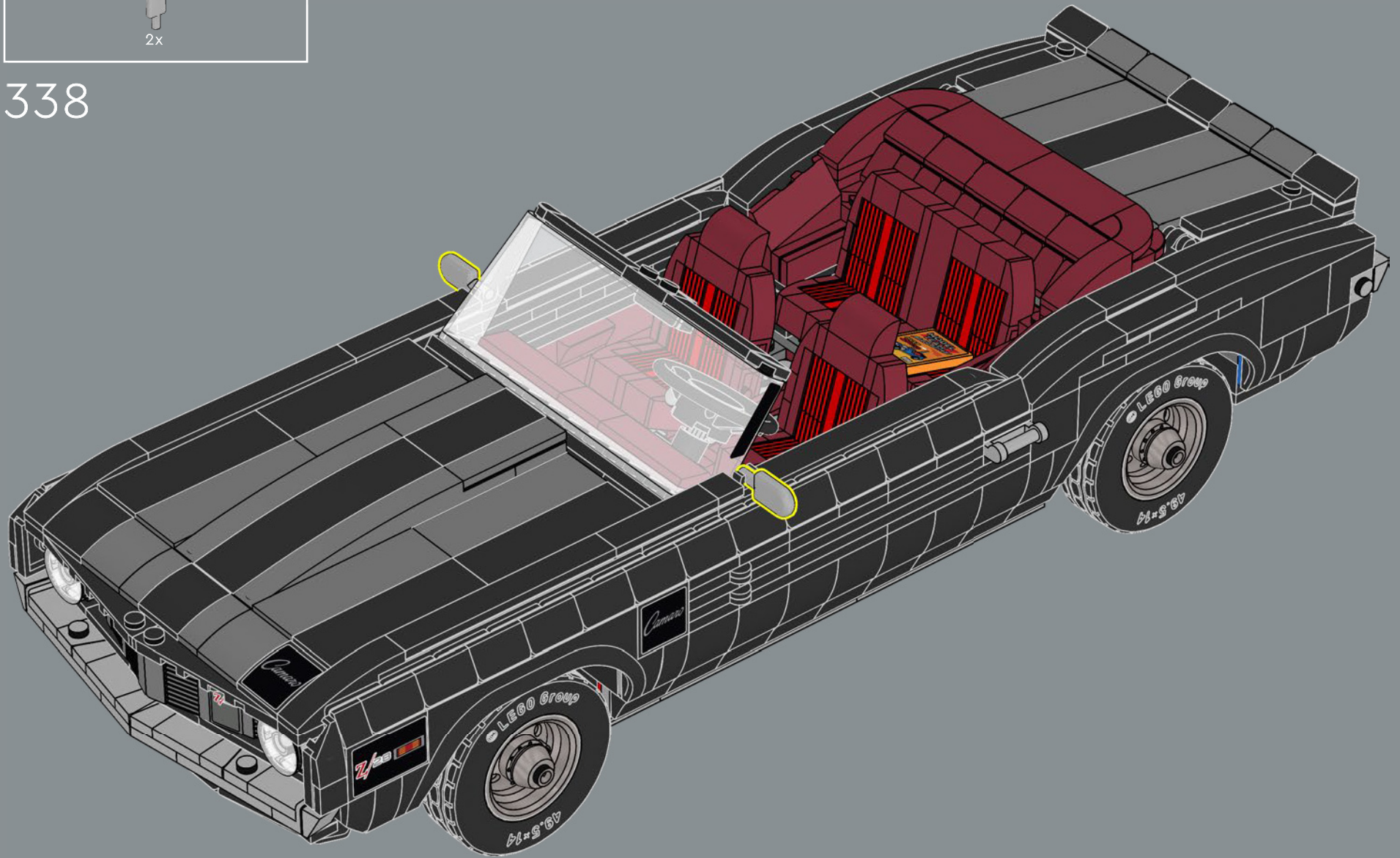

- 4x 4547489
- 2x 6034044
- 2x 6047220
- 4x 6276981
- 2x 6383985
- 4x 302201
- 2x 243101
- 2x 371001
- 2x 6104805
- 3x 302001
- 8x 6332042
- 2x 6035405
- 2x 6242241
- 3x 6347287
- 1x 6265740
- 2x 6146525
- 2x 614101
- 1x 6371416
- 1x 6289797
- 2x 4162465
- 8x 4118793
- 2x 6360037
- 8x 6024495
- 6x 4523145
- 8x 4121921
- 3x 4143409
- 3x 4249019
- 6x 6253003
- 2x 6013938
- 4x 4666579
- 2x 6416525
- 24x 6219677
- 2x 300321
- 2x 4558886
- 1x 654121
- 2x 370021
- 2x 6385920
- 1x 6275178
- 1x 330021
- 2x 307021
- 2x 302321
- 4x 6092565
- 2x 306921
- 6x 362321
- 2x 6378120
- 12x 371021
- 1x 303221
- 1x 303421
- 2x 6337002
- 2x 6347308
- 6x 6261351
- 5x 6168634
- 1x 6266205
- 8x 6168619
- 1x 6271820
- 3x 4142865
- 4x 6347789
- 1x 6130002
- 6x 393721
- 2x 300223
- 6x 6290531
- 1x 4212411
- 1x 6171063
- 2x 6057802
- 2x 306923
- 4x 6252060
- 2x 6196596
- 3x 303423
- 3x 6117968
- 4x 4206482
- 10x 6299413
- 2x 393723
- 2x 300524
- 2x 235724
- 2x 654124
- 14x 302324
- 2x 6195183
- 2x 6271167
- 1x 6170294
- 1x 6331822
- 2x 366624
- 6x 6248833
- 10x 300526
- 2x 4644456
- 4x 300426
- 6x 362226
- 2x 300226
- 5x 301026
- 2x 4584274
- 3x 370226
- 4x 4504382
- 53x 4548180
- 2x 4121966
- 4x 6267487
- 6x 366526
- 12x 6069000
- 1x 303926
- 2x 6176768
- 4x 428626
- 6x 428726
- 1x 6064228
- 5x 6181720
- 4x 6273589
- 2x 4107558
- 4x 302426
- 2x 6388352
- 6x 307026
- 44x 302326
- 8x 306926
- 2x 6214807
- 14x 6192346
- 4x 306826
- 2x 6312724
- 10x 302226
- 6x 242026
- 4x 6133722
- 4x 6195271
- 1x 403226
- 5x 6181713
- 2x 6184784
- 10x 6047276
- 26x 6053077
- 2x 6211476
- 2x 4618880
- 2x 6280394
- 1x 6319983
- 1x 6316923
- 1x 6331026
- 6x 6037746
- 6x 4647286
- 1x 6296083
- 4x 6037664
- 6x 243126
- 6x 371026
- 7x 302026
- 4x 4560182
- 2x 6350415
- 3x 663626
- 12x 366626
- 11x 6318582
- 6x 416226
- 1x 303226
- 1x 395826
- 14x 447726

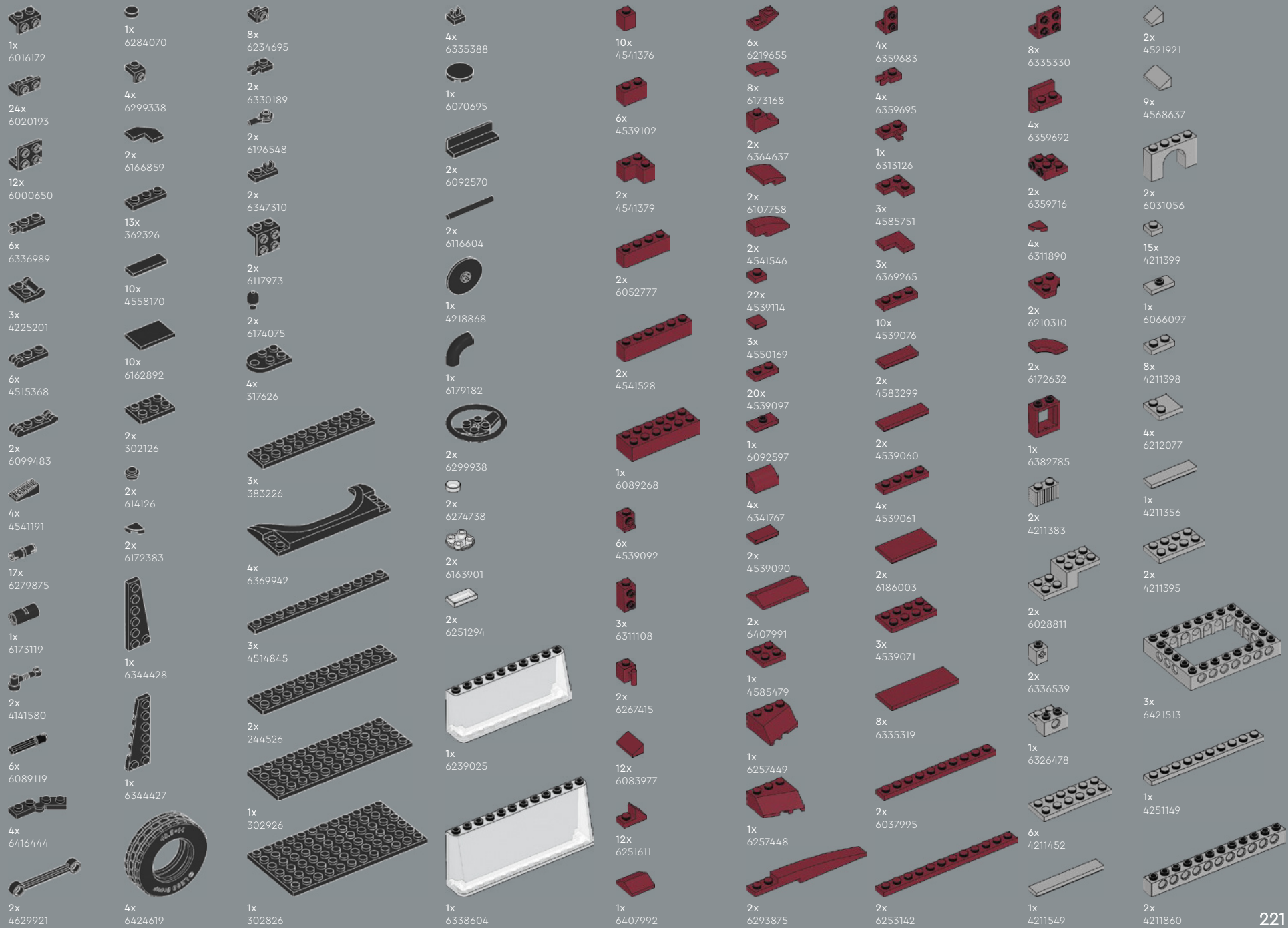

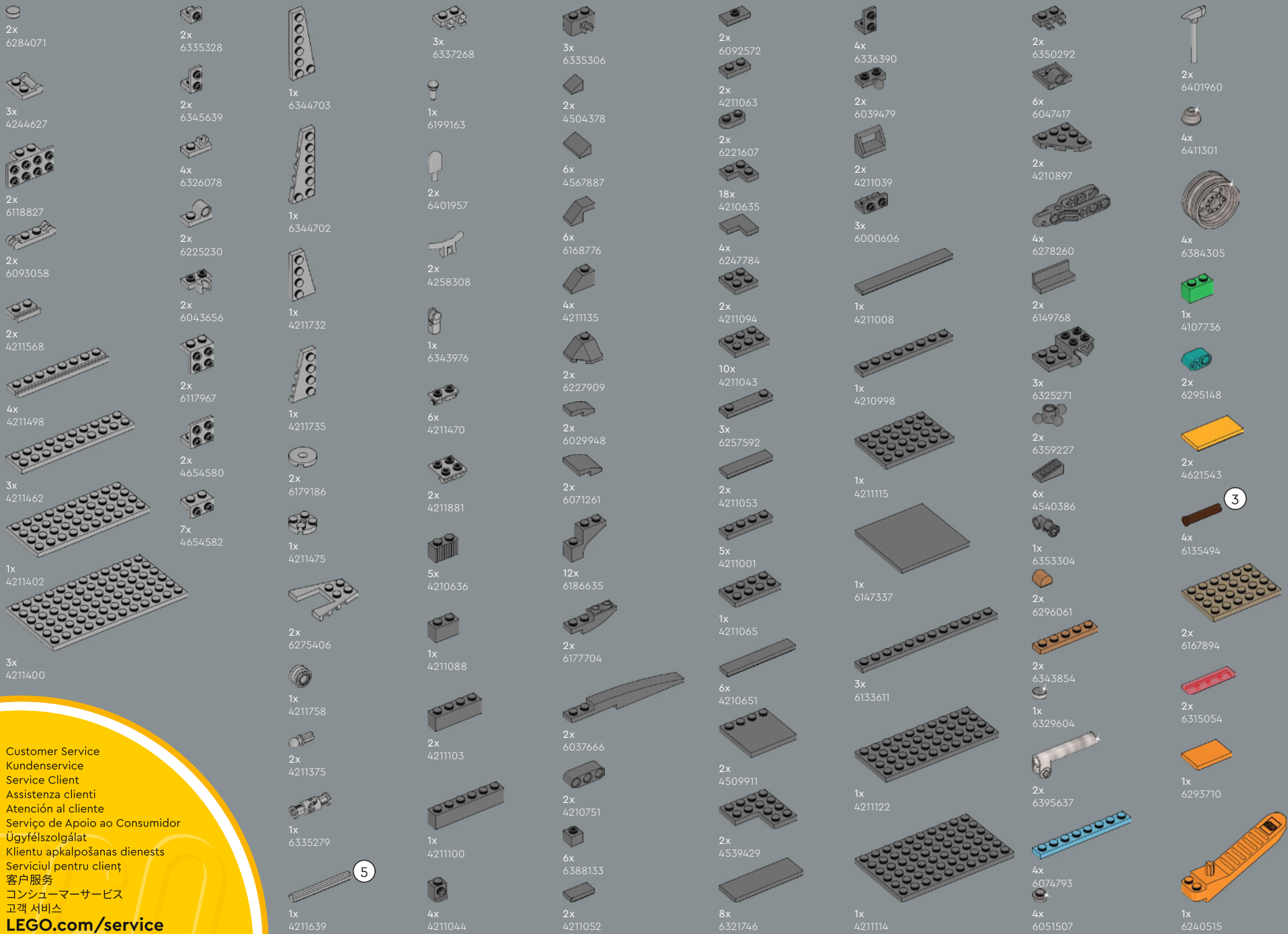

Customer Service
 Kundenservice
 Service Client
 Assistenza clienti
 Atención al cliente
 Serviço de Apoio ao Consumidor
 Ügyfélszolgálat
 Klientu apkalpošanas dienests
 Serviciul pentru clienț
 客户服务
 コンシューマーサービス
 고객 서비스
LEGO.com/service



FEEDBACK AND WIN



FEEDBACK AND WIN

Your feedback will help shape the future development of this product series.

Please visit:

FEEDBACK UND GEWINNEN

Dein Feedback trägt zur Weiterentwicklung dieser Produktreihe bei.

Geh auf:

COMMENTEZ ET GAGNEZ

Vos commentaires nous aideront à concevoir les futurs produits de cette gamme.

Rendez-vous sur :

COMENTA Y GANA

Tu opinión nos ayudará a dar forma al desarrollo de esta serie de productos en el futuro.

Visita:

反馈有奖

您的反馈将有助于我们在今后改进本系列产品。

请访问：

[LEGO.com/productfeedback](https://www.lego.com/productfeedback)

By completing, you will automatically enter a drawing to win a LEGO® set.

Terms & Conditions apply.

Durch Ausfüllen nimmst du automatisch an der Verlosung eines LEGO® Preises teil.

Es gelten die Teilnahmebedingungen.

En envoyant vos commentaires, vous serez automatiquement inscrit(e) à un tirage au sort qui vous permettra de remporter un prix LEGO®.

Offre soumise à conditions.

Al contestar, participarás automáticamente en el sorteo y podrás ganar un set LEGO®.

Sujeto a Términos y Condiciones.

完成我们的反馈调查，即可自动进入抽奖环节，赢取乐高®套装。

适用《条款和条件》。



LEGO and the LEGO logo are trademarks of the LEGO Group. ©2022 The LEGO Group.

General Motors trademarks used under license to the LEGO Group.