

---

# TITANIC

BUCH 1

→ Eine Postkarte der White Star Line mit der Titanic als Motiv.

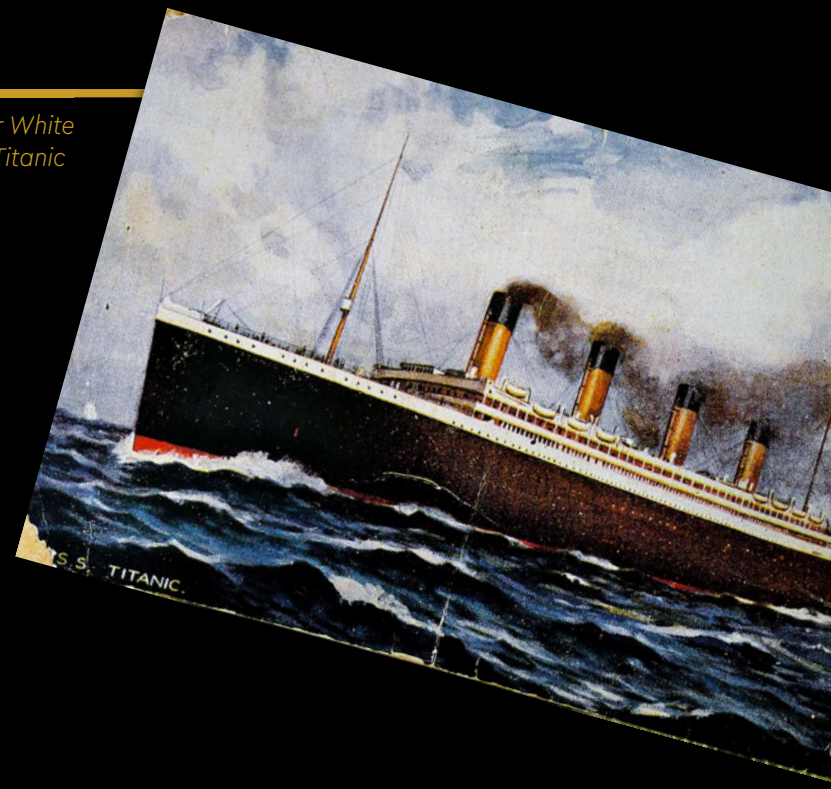

---

# DIE KÖNIGIN DER OZEANE

Als die RMS Titanic am 10. April 1912 aus Southampton (England) zur Jungfernfahrt nach New York City auslief, war sie nicht nur das größte Schiff jener Zeit, sondern auch das luxuriöseste. Sie war der zweite von drei Dampfern der Olympic-Klasse, die von der White Star Line in Dienst gestellt wurden, um die Vormachtstellung der Reederei auf der lukrativen Transatlantikroute zu festigen. Die Werft „Harland and Wolff“ in Belfast bekam freie Hand bei den Ausgaben, um mit der Titanic völlig neue Maßstäbe in puncto Luxus und Komfort zu setzen.



↑ Die RMS Titanic beim Auslaufen  
aus Southampton am 10. April 1912.

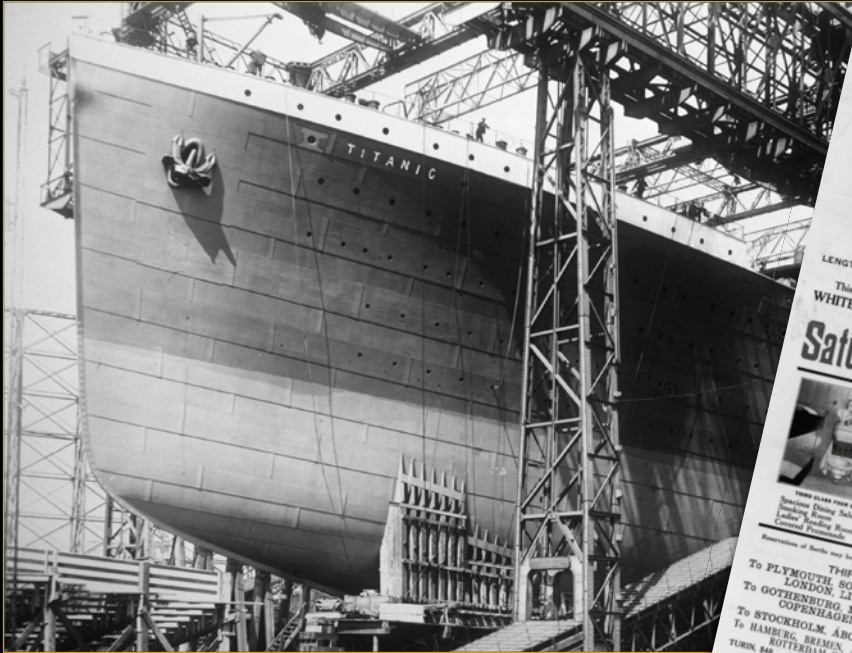

↑ Der in Bau befindliche Bug der Titanic in der Werft „Harland and Wolff“ in Belfast (Irland).

**WHITE STAR LINE**  
 ROYAL & UNITED STATES MAIL STEAMERS  
 FIRST SAILING OF THE LATEST ADDITION TO THE WHITE STAR FLEET  
 The Queen of the Ocean  
**TITANIC**

LENGTH 852 FT. OVER 45,000 TONS TRIPLE-SCREWS BEAM 92 FT.  
 This, the Largest, Largest and Finest Steamer Afloat, will sail from  
**WHITE STAR LINE, PIER 59 (North River), NEW YORK**  
**Saturday, April 20th** At 12 Noon

**THIRD CLASS COOK BERTH ROOM**  
 Spacious, Double Bunked  
 Linen, Bedding, Food  
 General Provision, etc.

**THIRD CLASS DINING SALON**  
 All passengers berthed in closed rooms containing 2, 3, or 4 berths, a large room-ber equipped with washstands, etc.

Reservations of Berths may be made direct with the Office at through one of our accredited Agents

**THIRD CLASS RATES ARE:**

To PLYMOUTH SOUTHAMPTON LONDON LIVERPOOL and GLASGOW.	\$36.25
To GOTHENBURG MALMÖ CHRISTIANIA, COPENHAGEN, ESBJERG, Etc.	41.50
To STOCKHOLM, ÅBO, HANGÖ, HELSINGFORS, HAMBURG, BREMEN, ANTWERP, AMSTERDAM, ROTTERDAM, HAVRE, CHERBOURG, NAPLES, BRINDISI, GENOA, etc.	44.50
TO NOT DELAY. (Passage and Freight through the White Star Line Agents in direct from) TURIN, BARI, PISA, etc.	45.00

WHITE STAR LINE, 9 Broadway, New York  
**TICKETS FOR SALE HERE**

← 1912: Eine Kleinanzeige zur Jungfernfahrt der Titanic, der die Abfahrtszeit des Luxuspassagierschiffs zu entnehmen ist. Auch die Ticketpreise und Beschreibungen der Kojen sind angegeben.



→ Zwei Passagierschiffe der White Star Line, die RMS Titanic und die RMS Olympic, bei ihrem letzten gemeinsamen „Auftritt“ am 3. Februar 1912.

---

# DIE DREI SCHIFFSSCHRAUBEN – DAS MARKENZEICHEN DER OLYMPIC-KLASSE

Die Titanic besaß drei Schiffsschrauben. Jede davon wurde von einer eigenen leistungsstarken Maschine angetrieben. Die beiden äußeren Dampfmaschinen waren 19 Meter lang und 720 Tonnen schwer. Zusammen brachten sie es auf eine Leistung von 30.000 PS. Die mittlere Niederdruckturbine leistete zusätzliche 16.000 PS. In den 29 Kesseln der Dampfmaschinen wurden jeden Tag 484,5 Tonnen Wasser und 600 Tonnen Kohle verbraucht. Alle drei Maschinen waren durch lange Wellen direkt mit den Schiffsschrauben verbunden. Die beiden äußeren Schiffsschrauben hatten einen Durchmesser von 7,2 Metern, der kleinere mittlere Propeller besaß dagegen einen Durchmesser von 5,2 Metern. Dank dieser beträchtlichen Maschinenleistung konnte die Titanic eine Höchstgeschwindigkeit von 23 Knoten (mehr als 42 km/h!) erreichen.

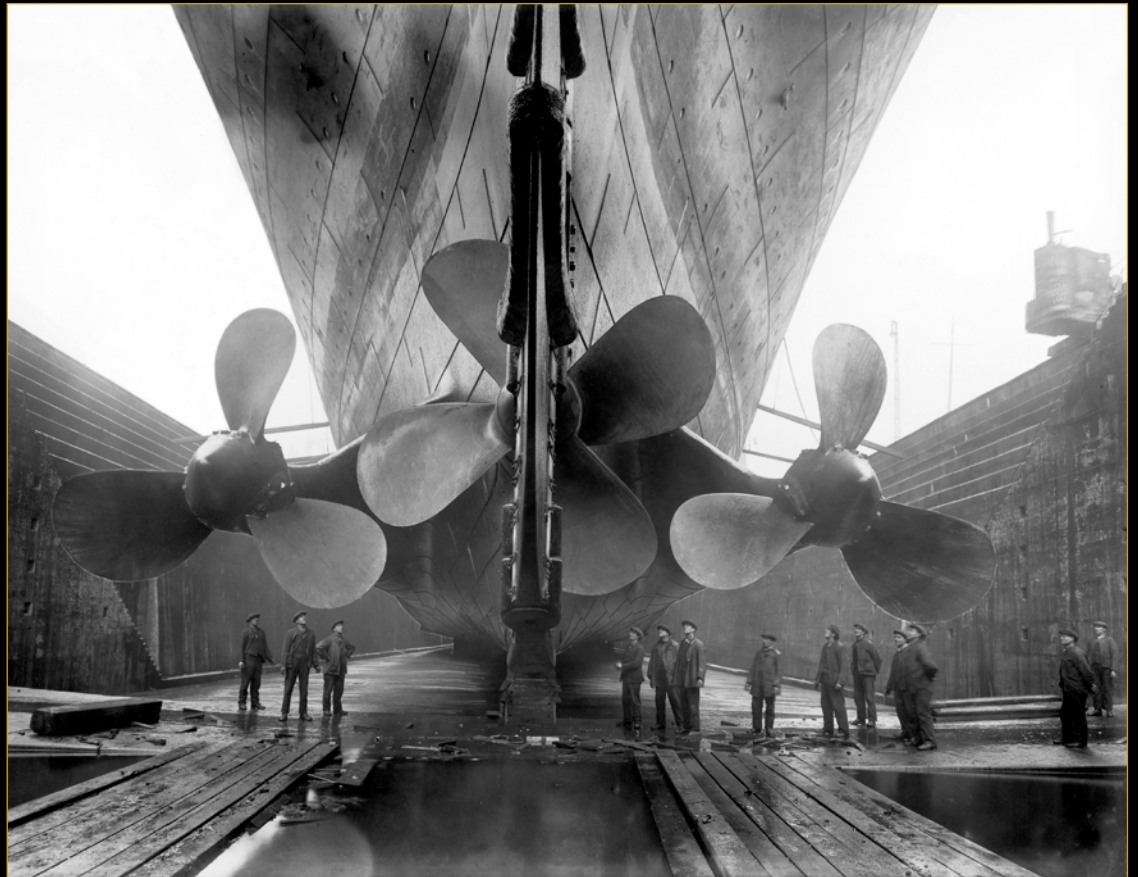

↑ Die riesigen Propeller der RMS Titanic, als der Ozeanriese im Trockendock lag.



[LEGO.com/brickseparator](https://LEGO.com/brickseparator)

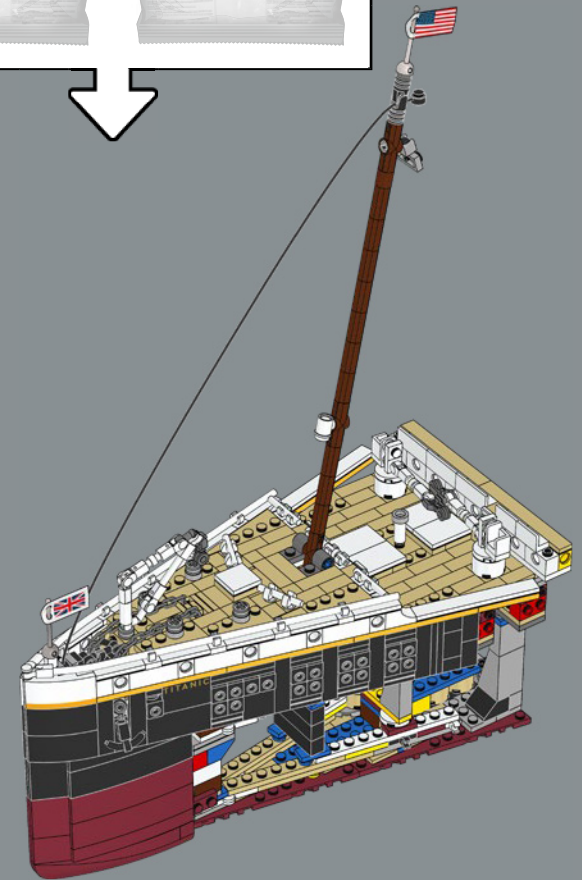
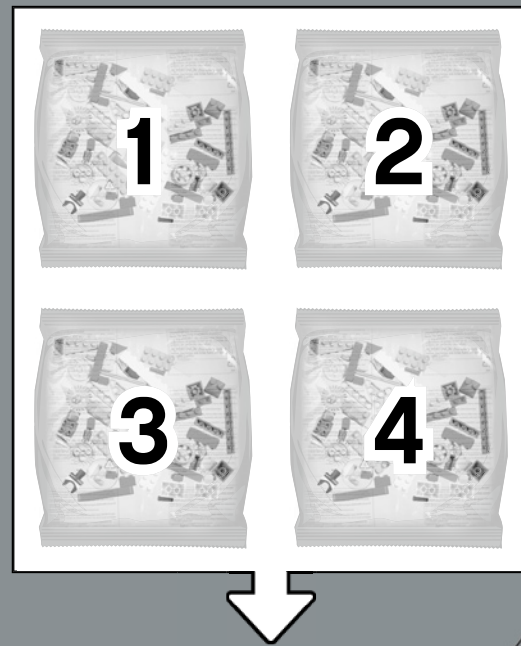

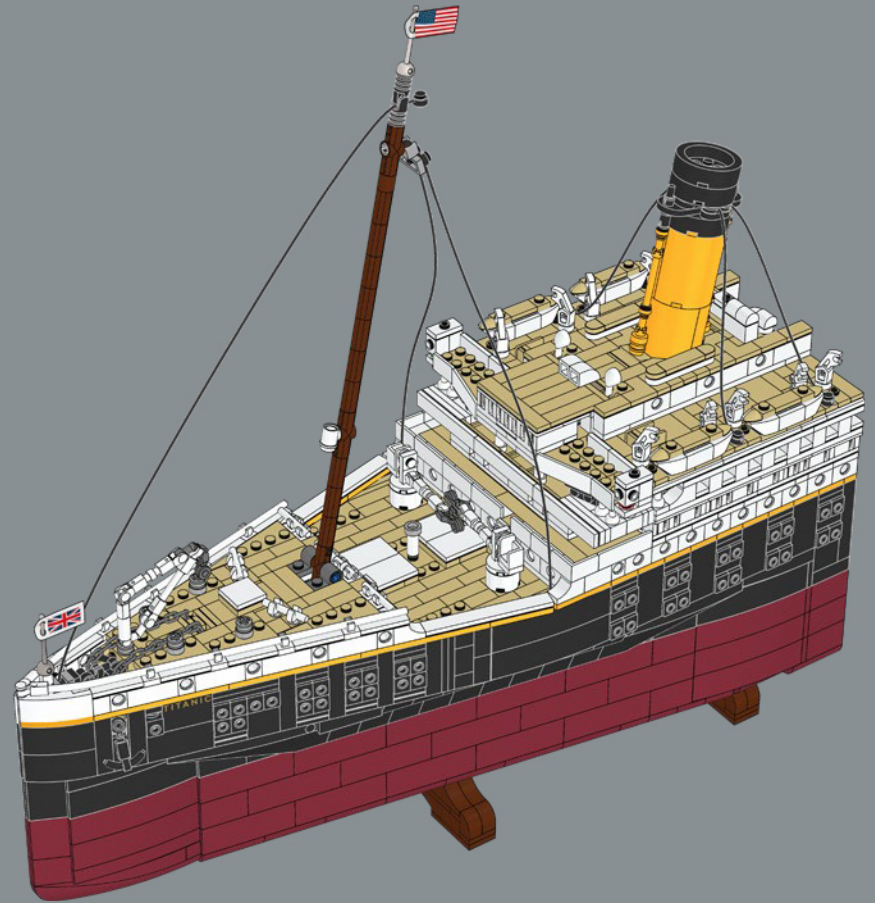
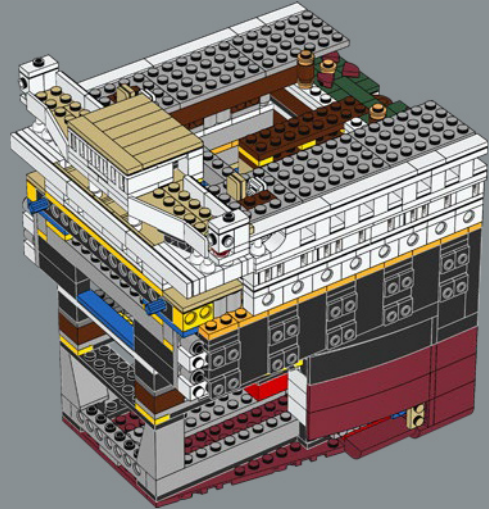
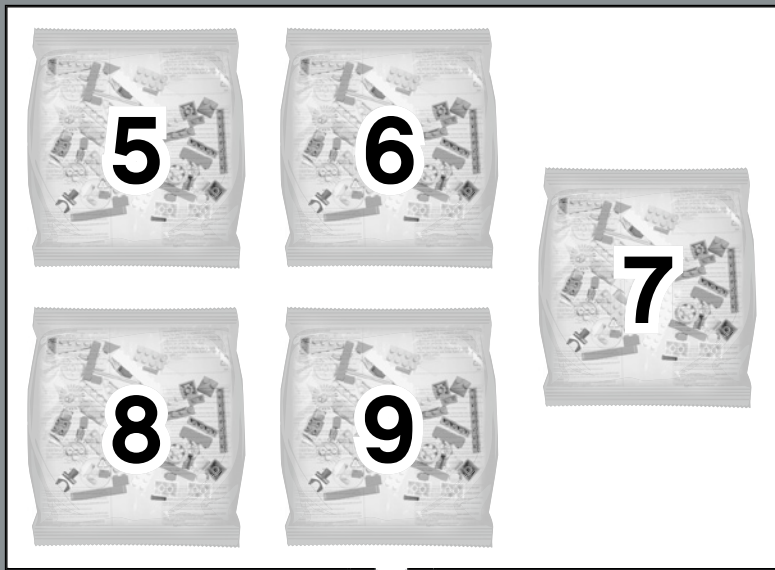

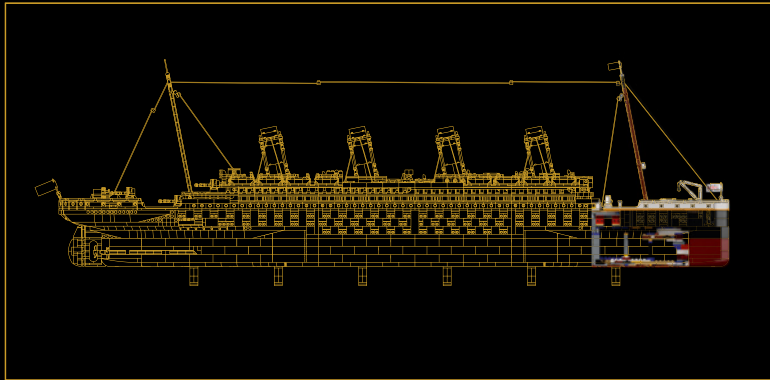

#### ABSCHNITT 1:

# BUG UND WELLDECK

In diesem Abschnitt baust du den Bug des Schiffs. Das schließt auch die Anker, den Schiffsnamen, das Welldeck, die Frachtluken und die Frachtkräne, den Ankerkran mit dem 3. Anker und den vorderen Mast ein. Im Inneren des Schiffes werden die Konstruktionen gebaut, die den spitz zulaufenden vorderen Rumpf tragen. Diese lassen sich mit den Stützkonstruktionen der späteren Bauabschnitte verbinden, um den Bug des Modells zu vollenden.

↓ Wir benutzen den dreifach gebogenen 2x10x2 Stein, um die Vorderseite des Kiels zu formen.





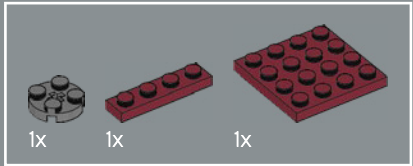
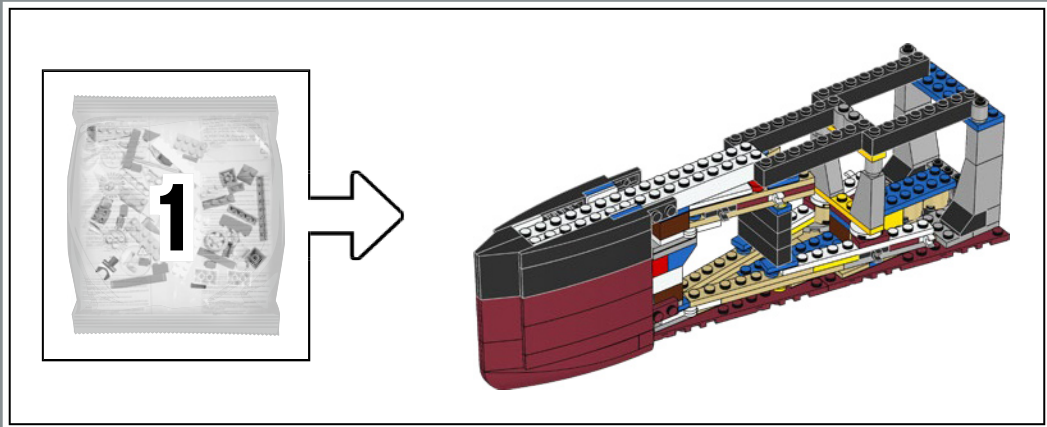

2

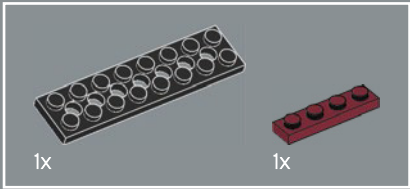

1

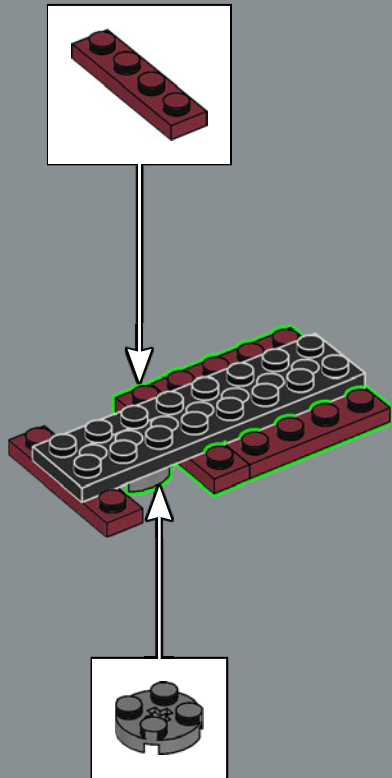
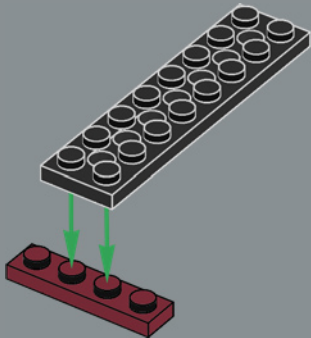

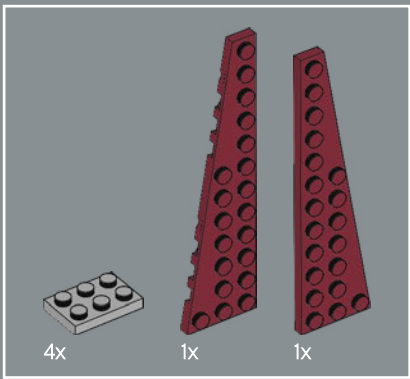

3

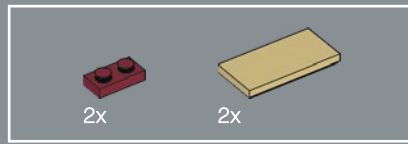
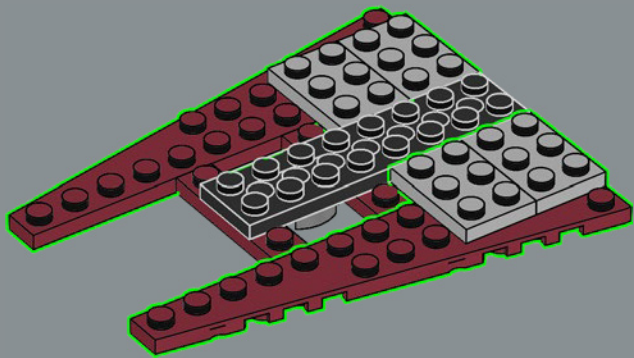

4

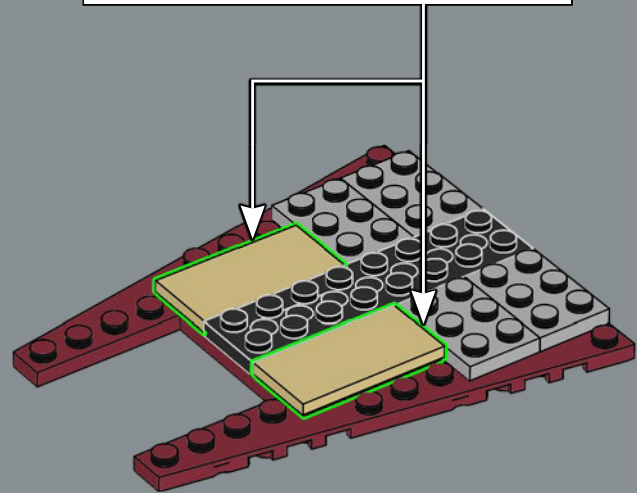
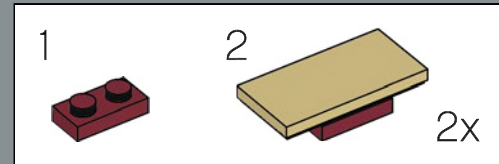

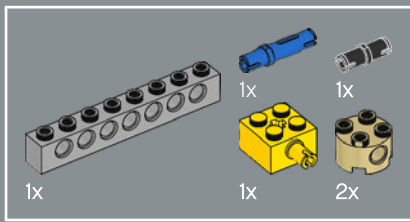

5

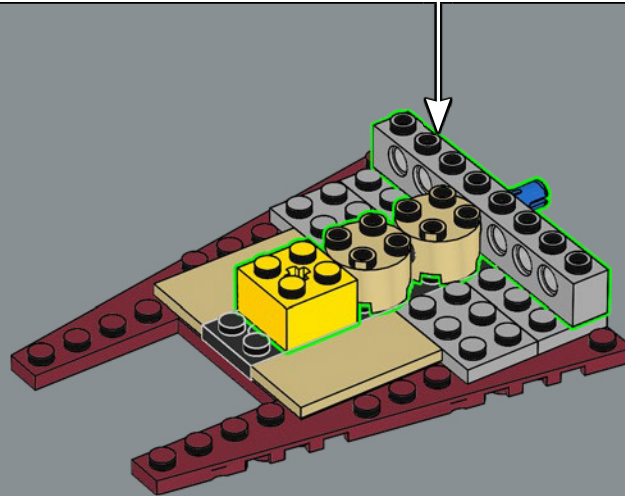
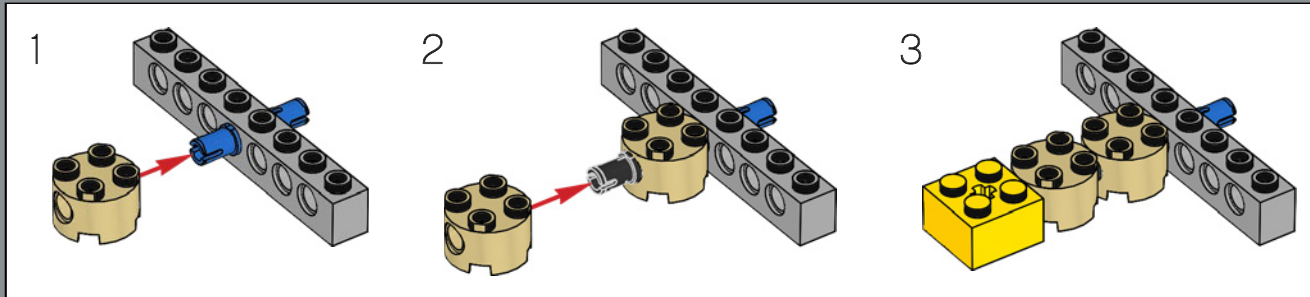

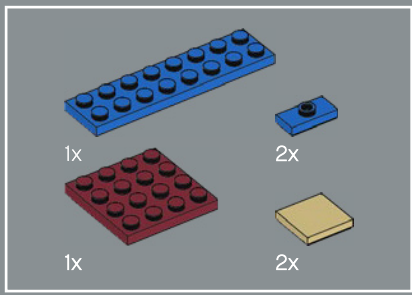

6

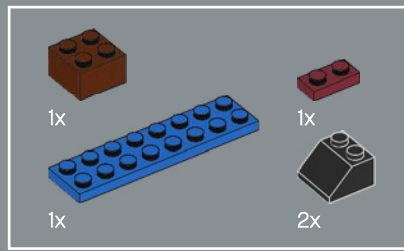
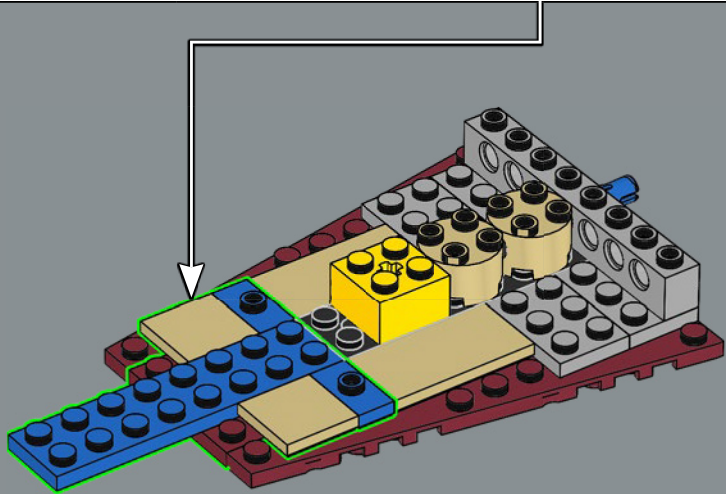
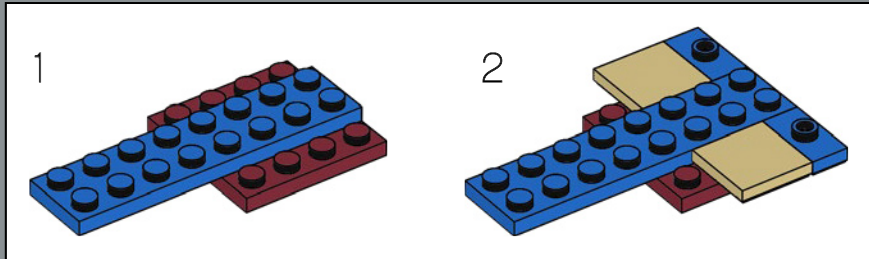

7

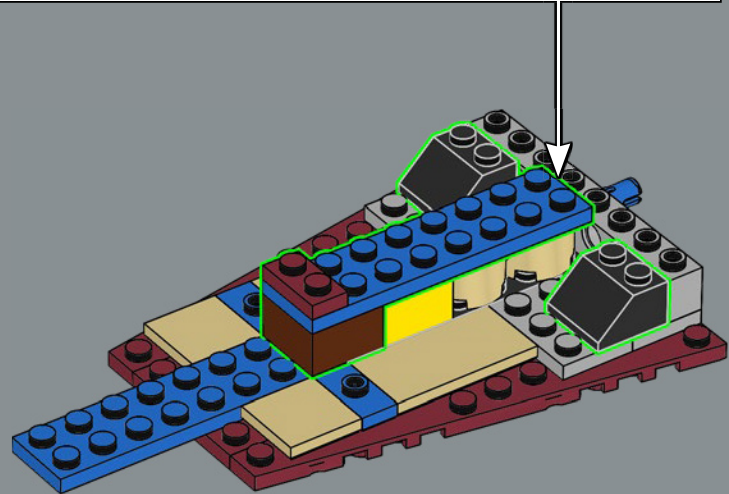
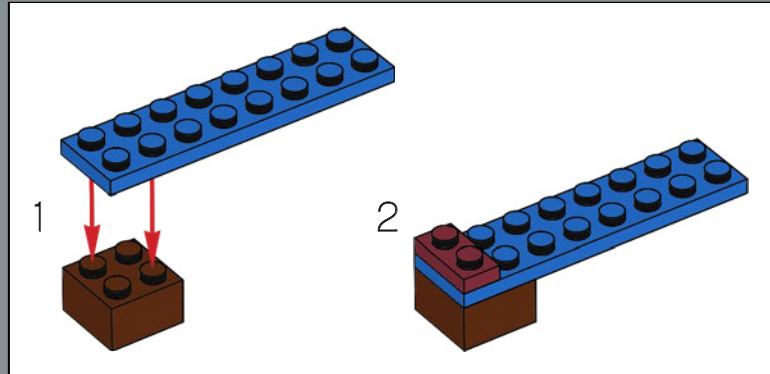

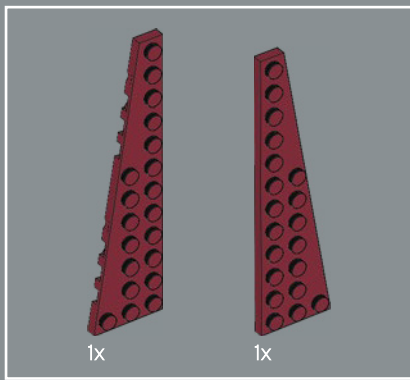

8

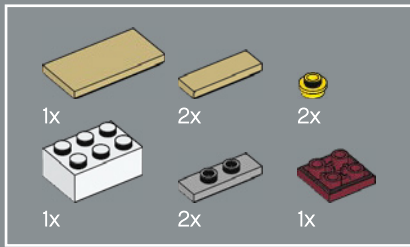
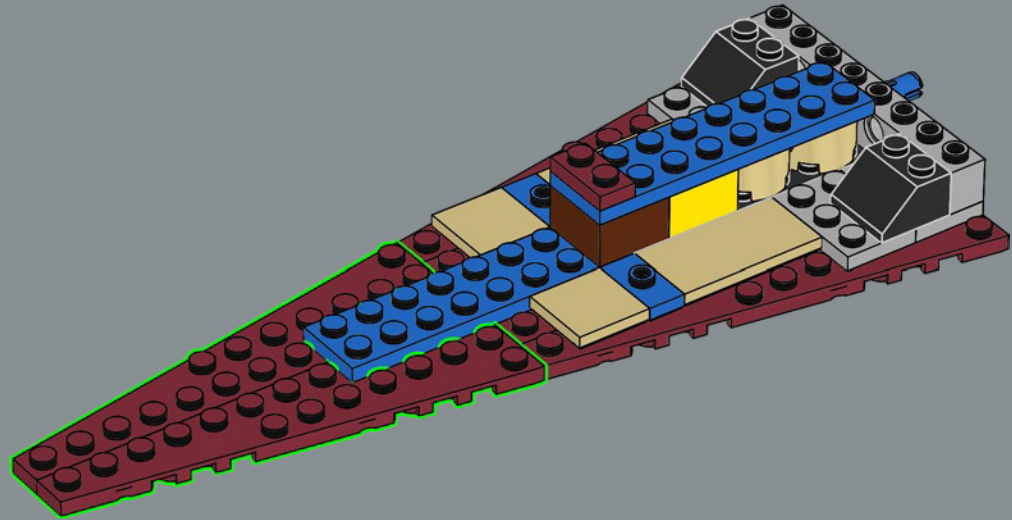

9

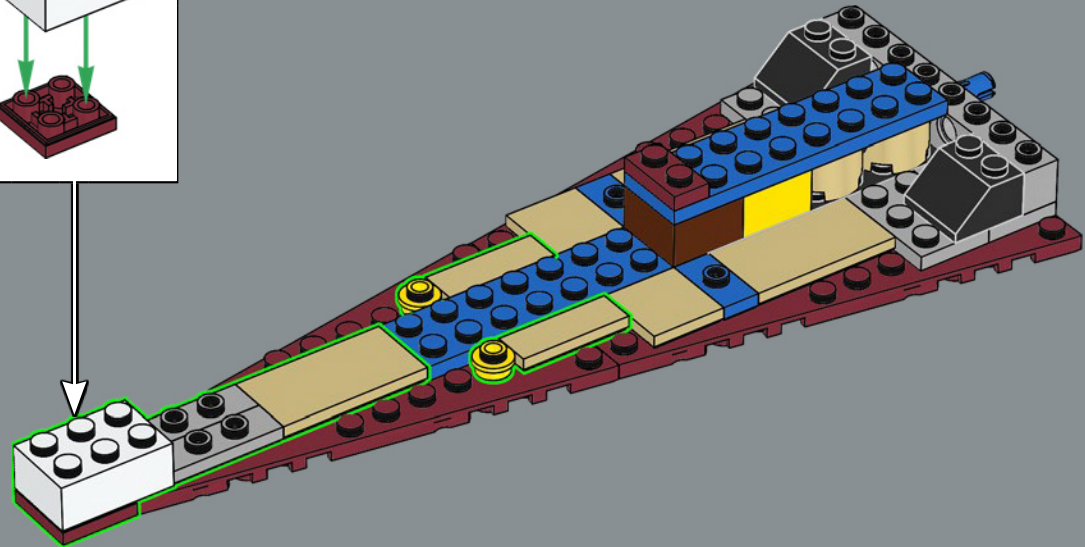
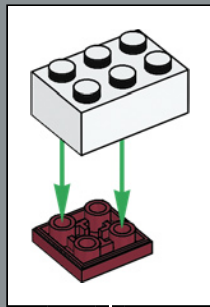



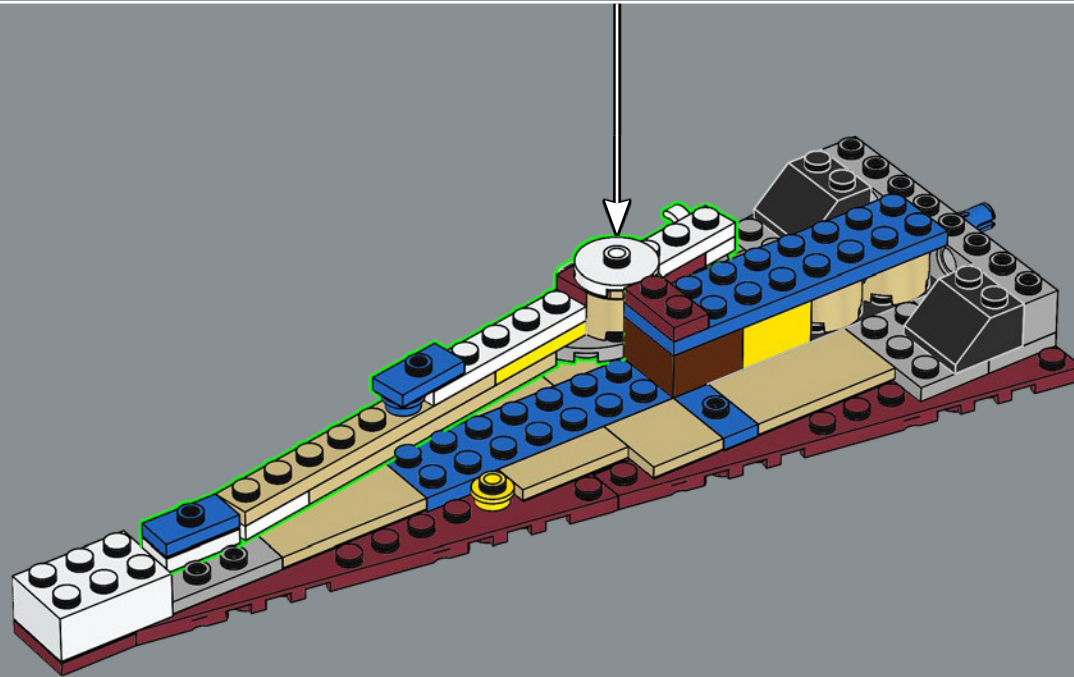
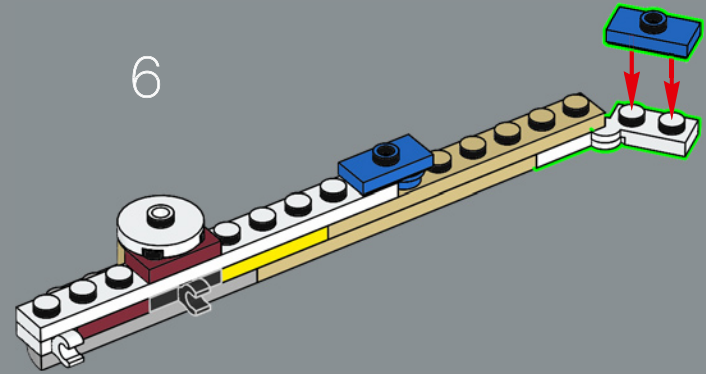
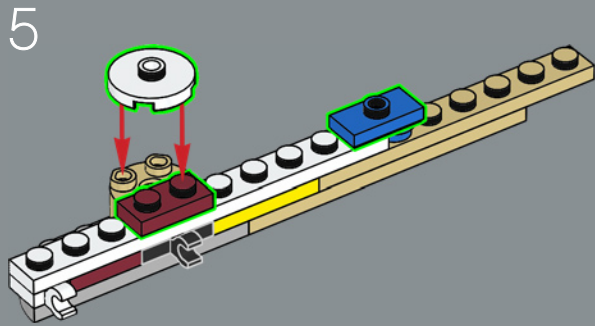





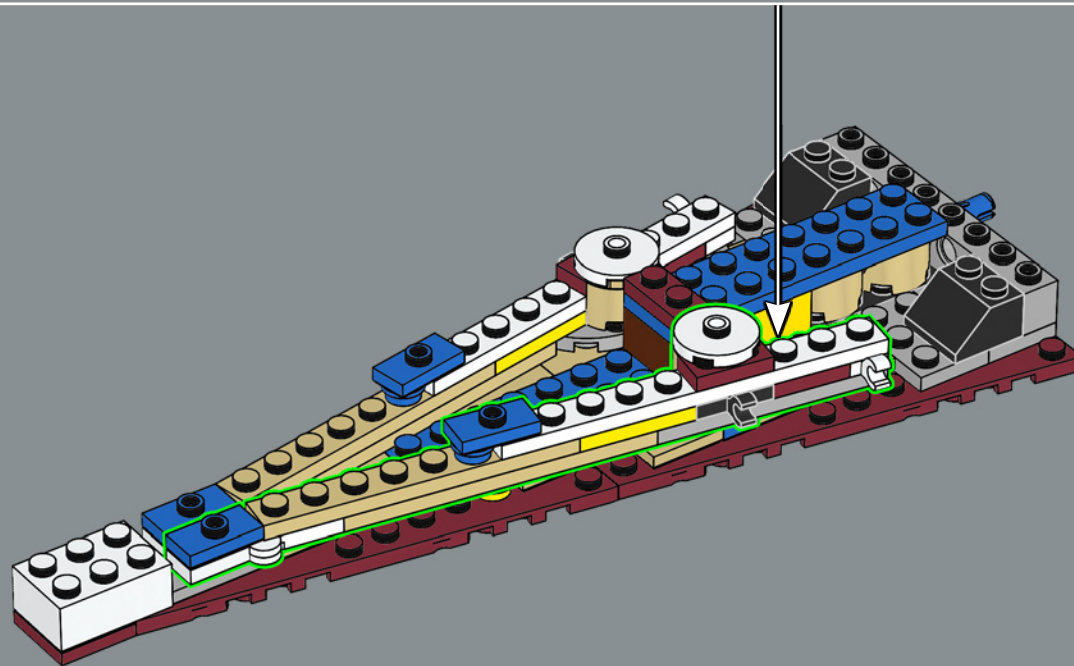
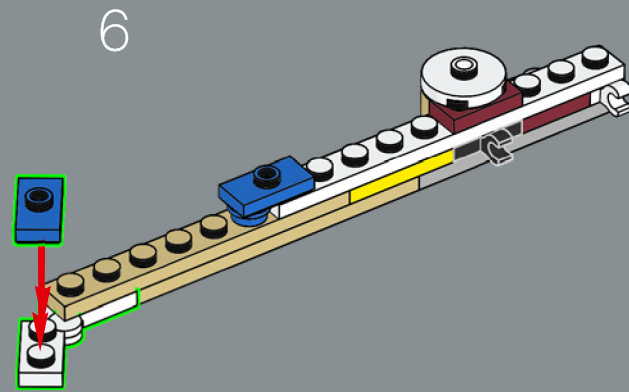
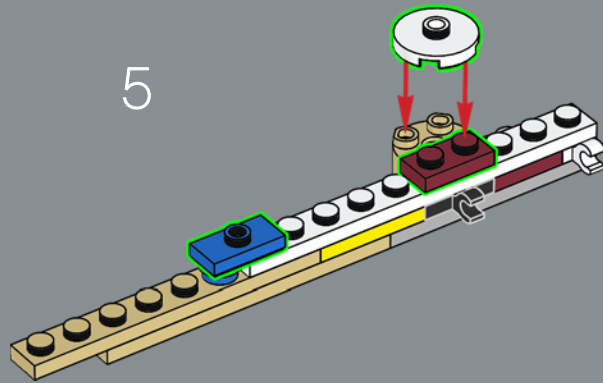

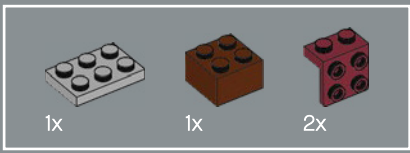

12

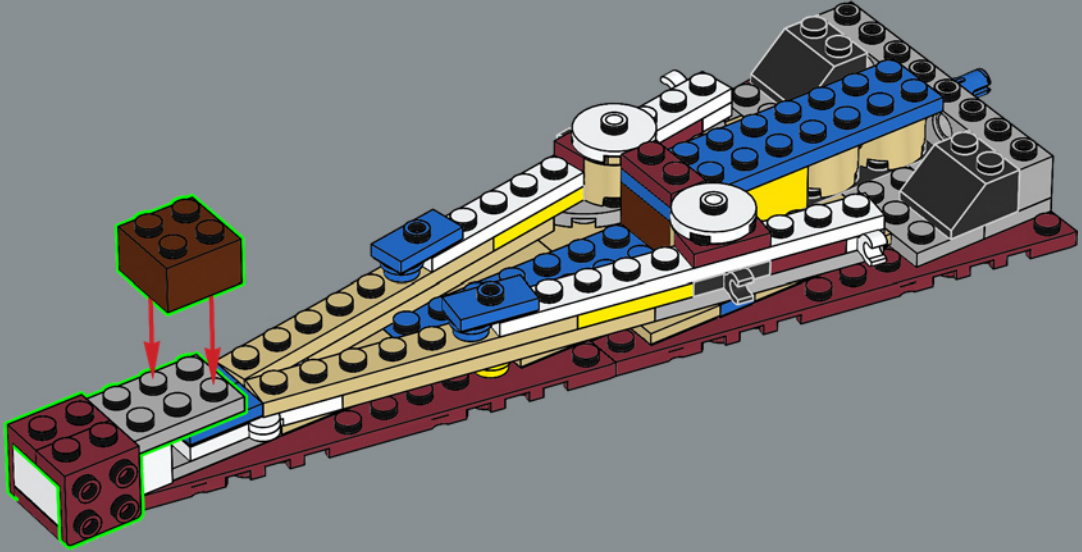

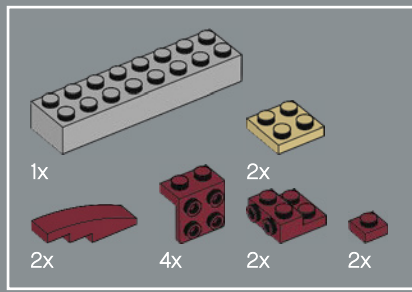

13

1

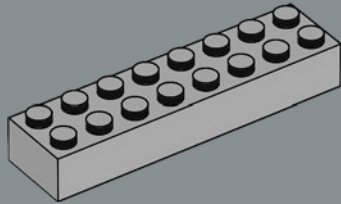

2

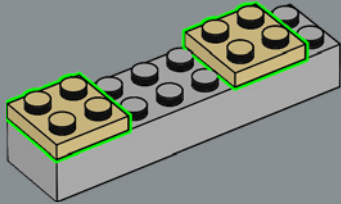

3

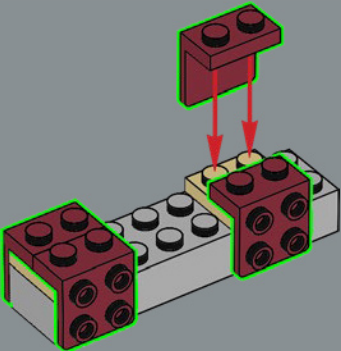

4

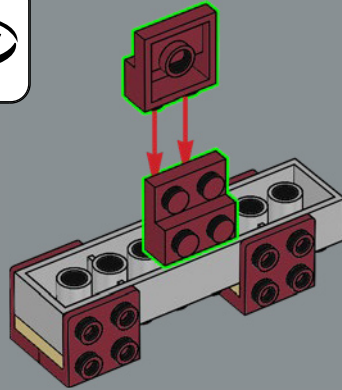

5

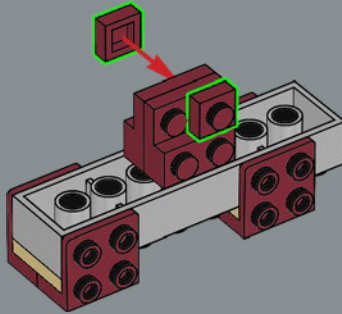

6

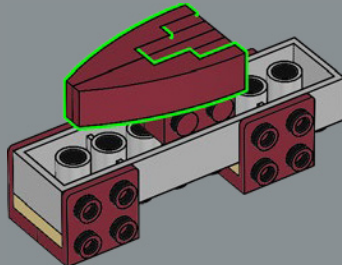

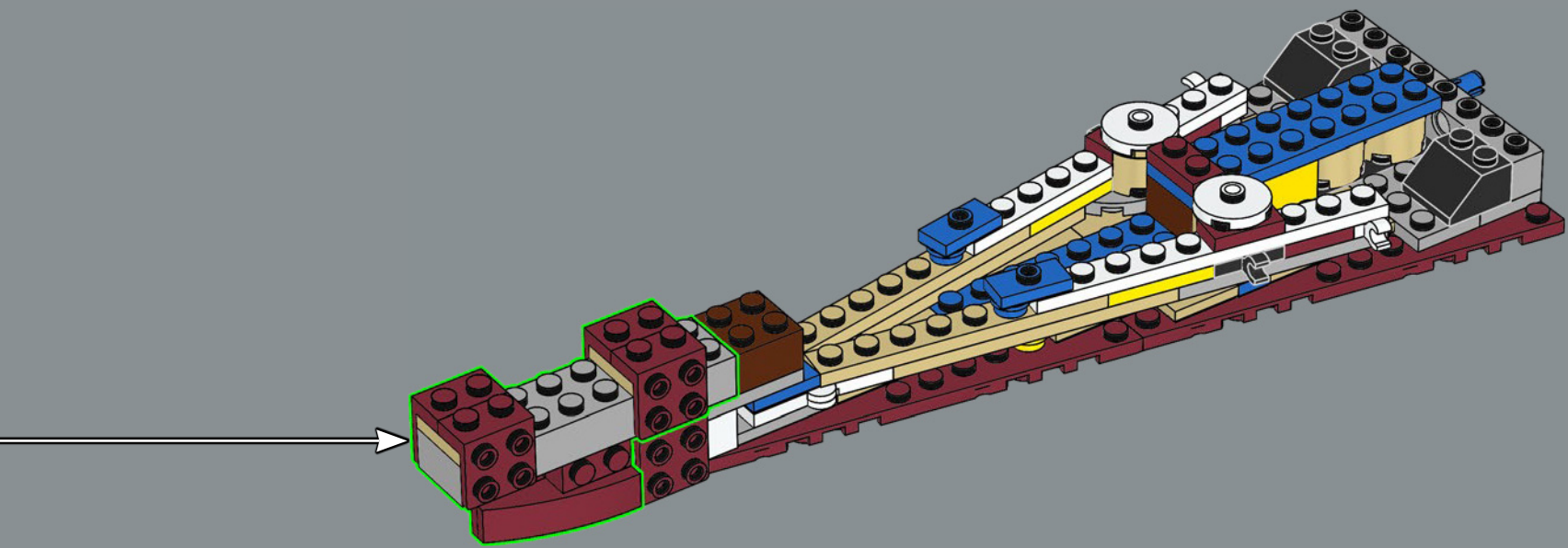

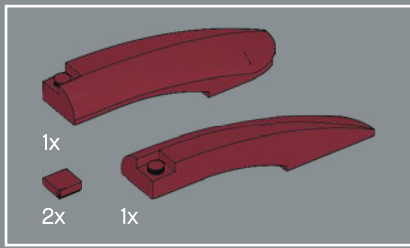

14

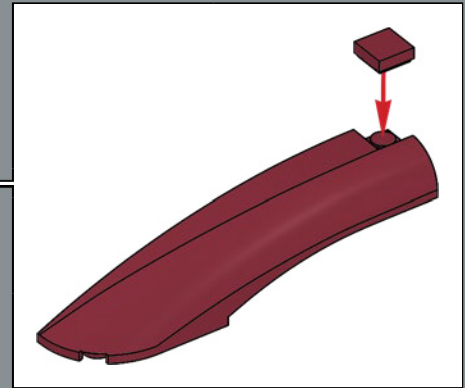
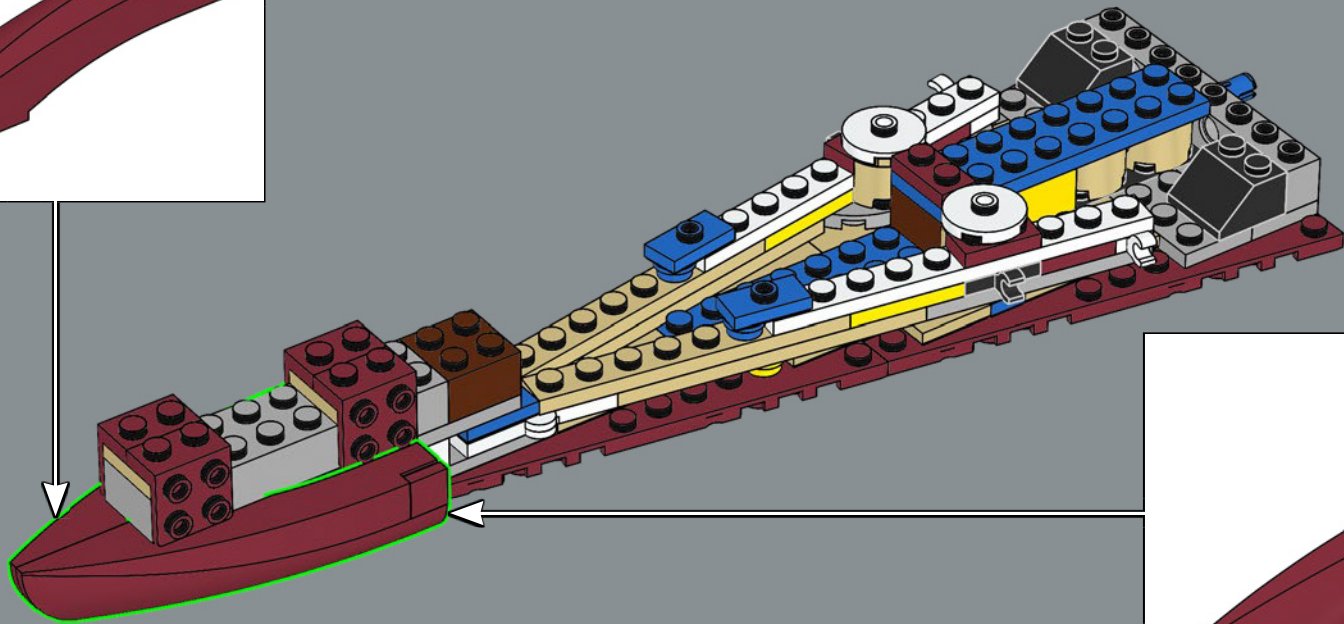
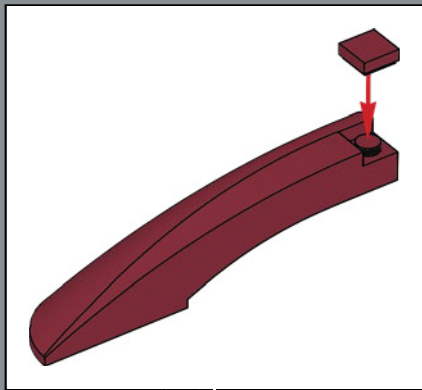

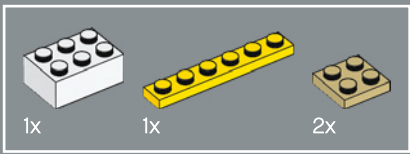

15

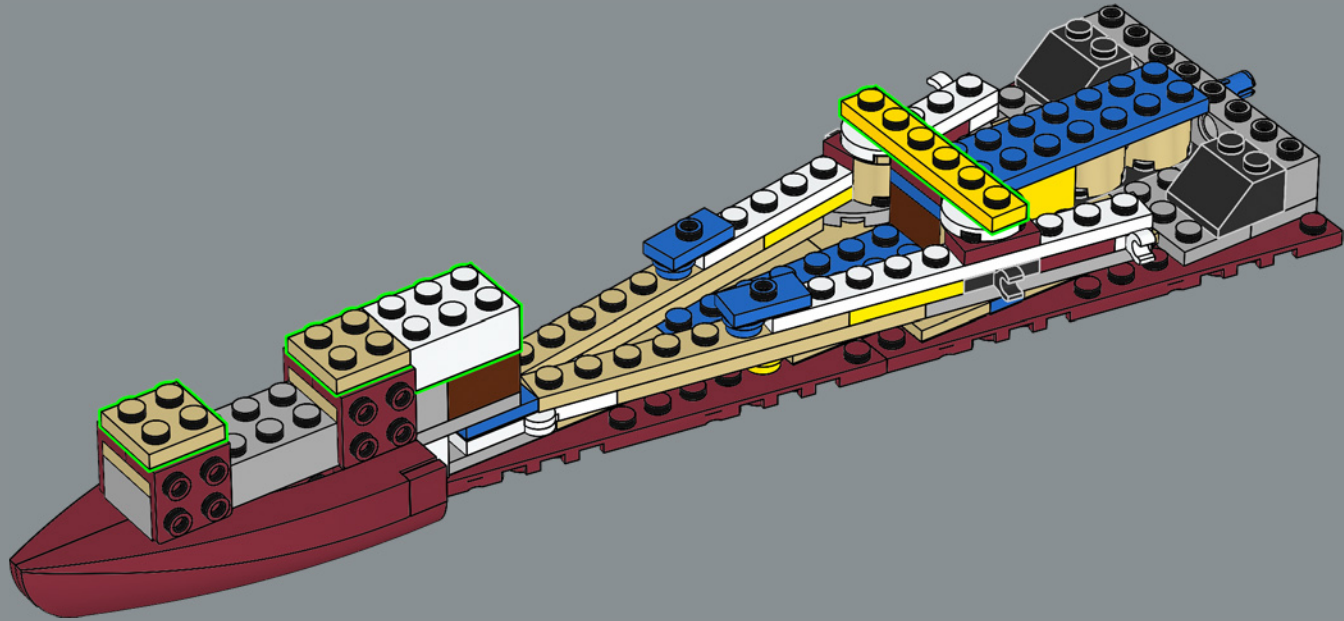

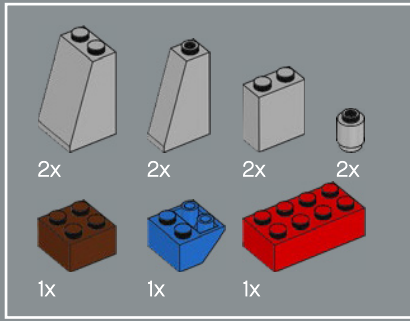

16

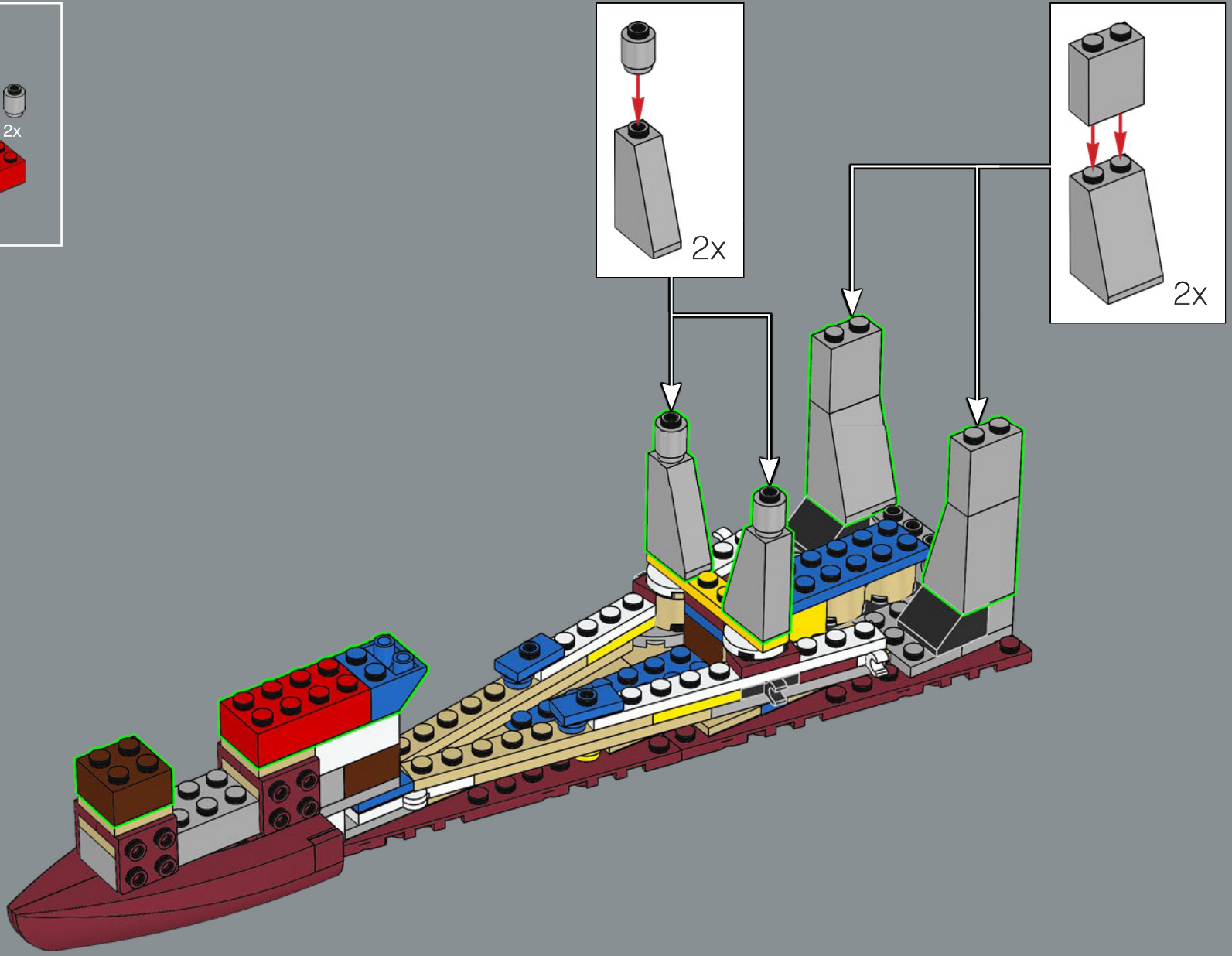

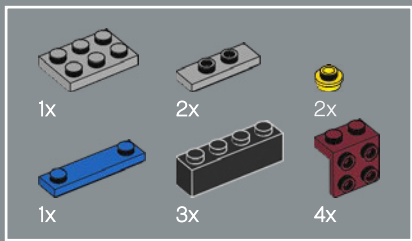

17

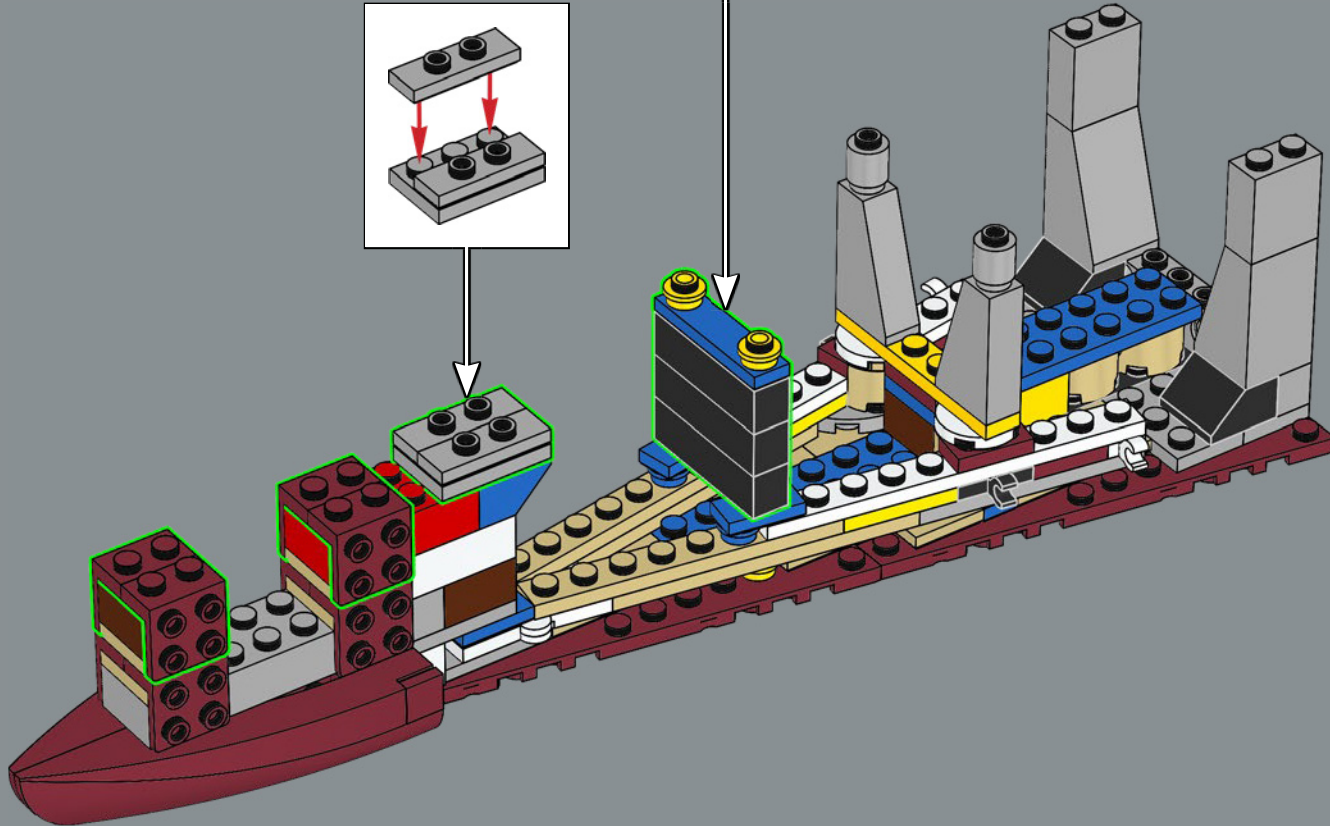
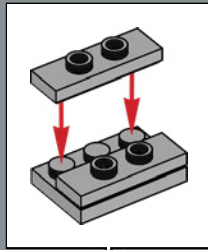
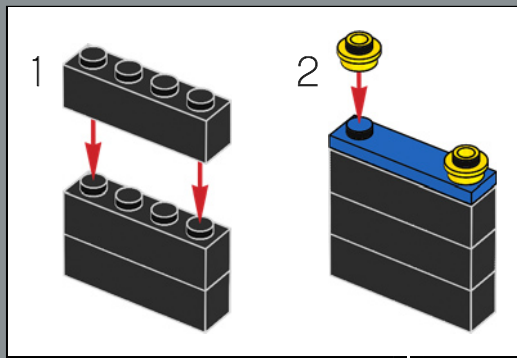



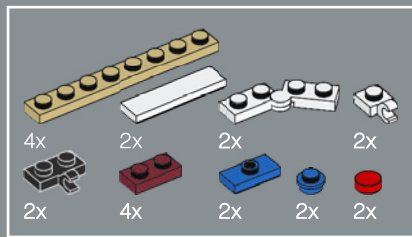

18

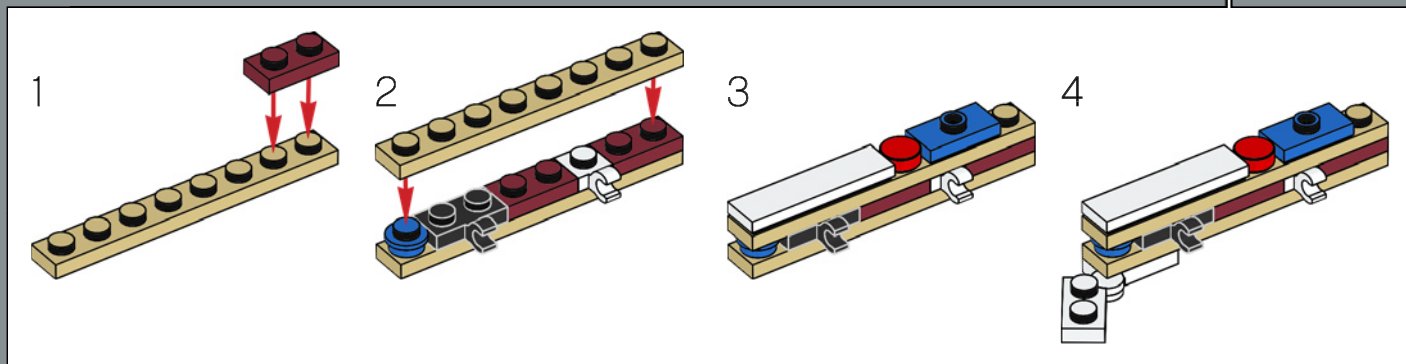
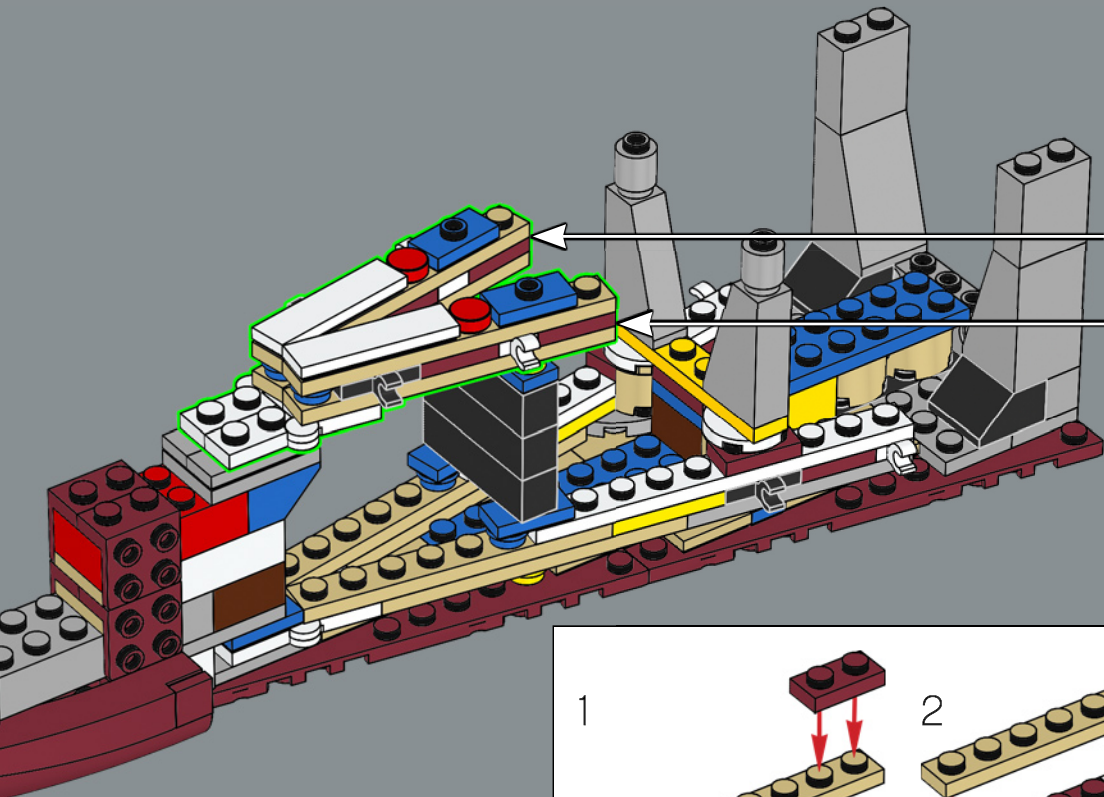
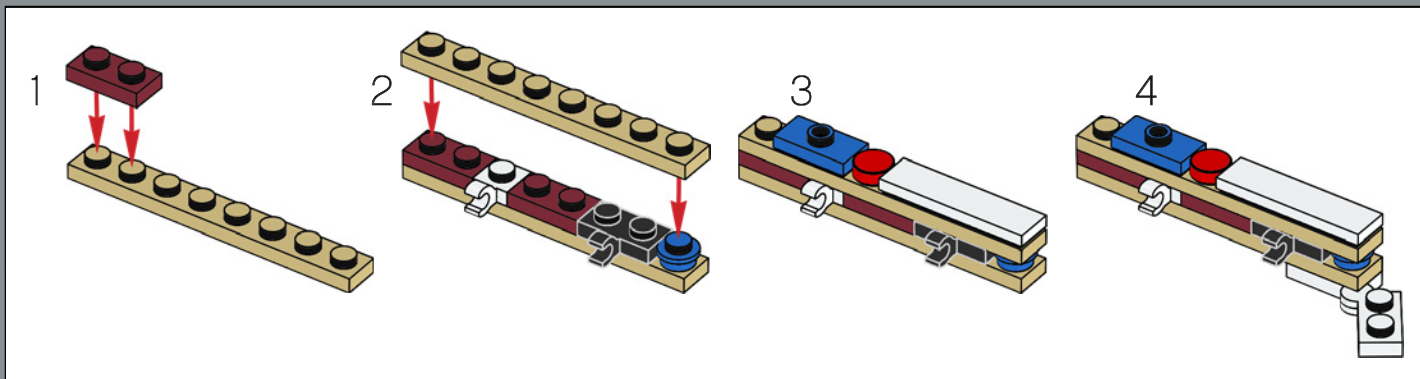

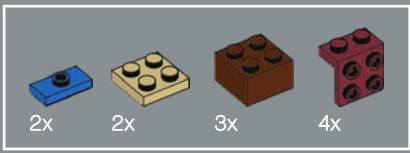

19

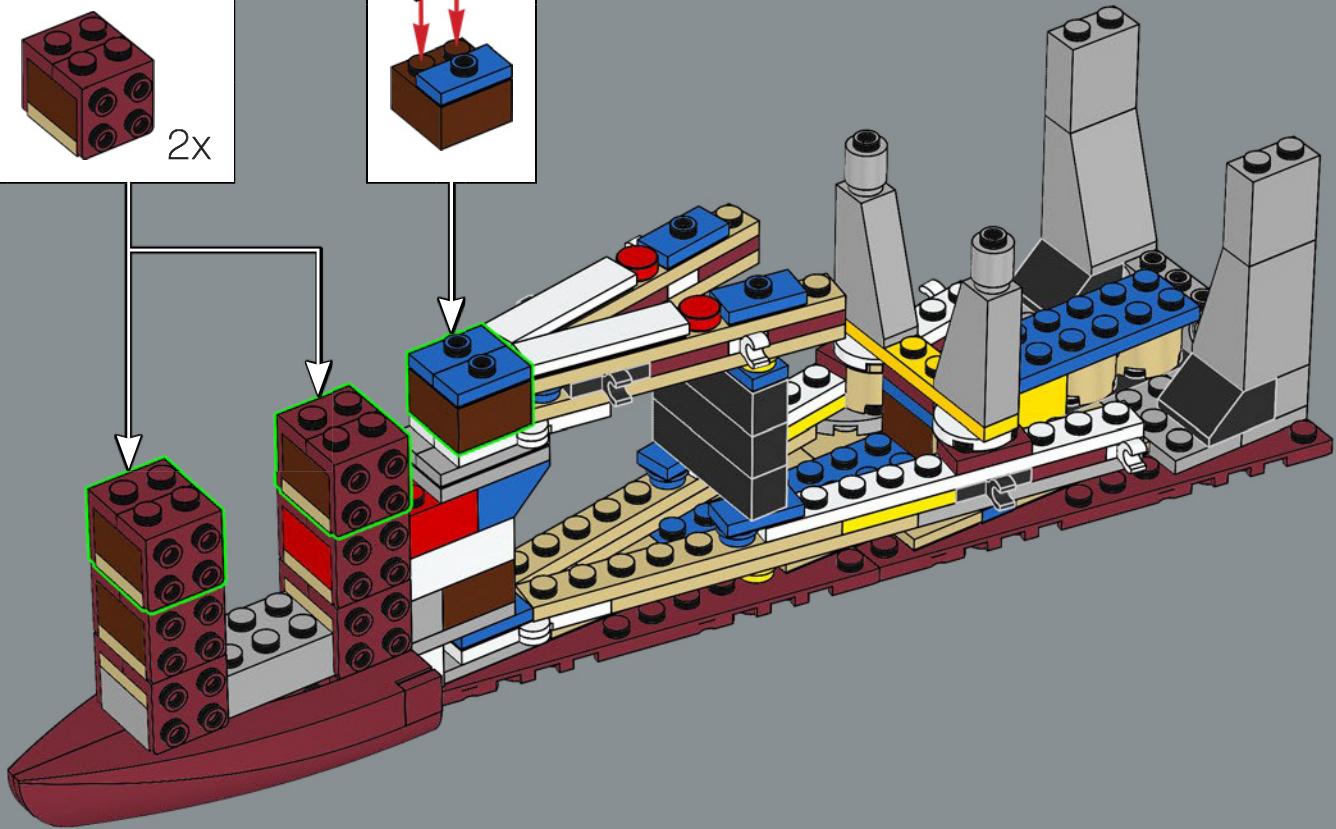
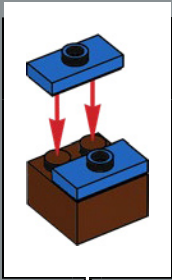
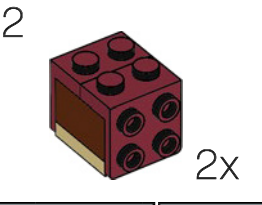
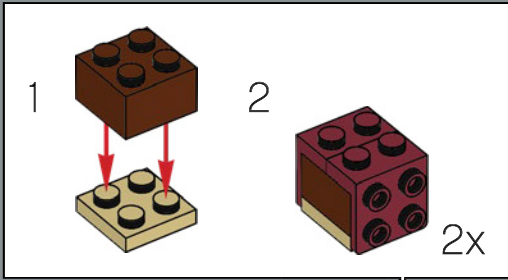

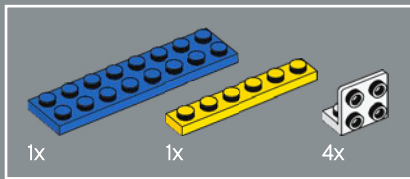

20

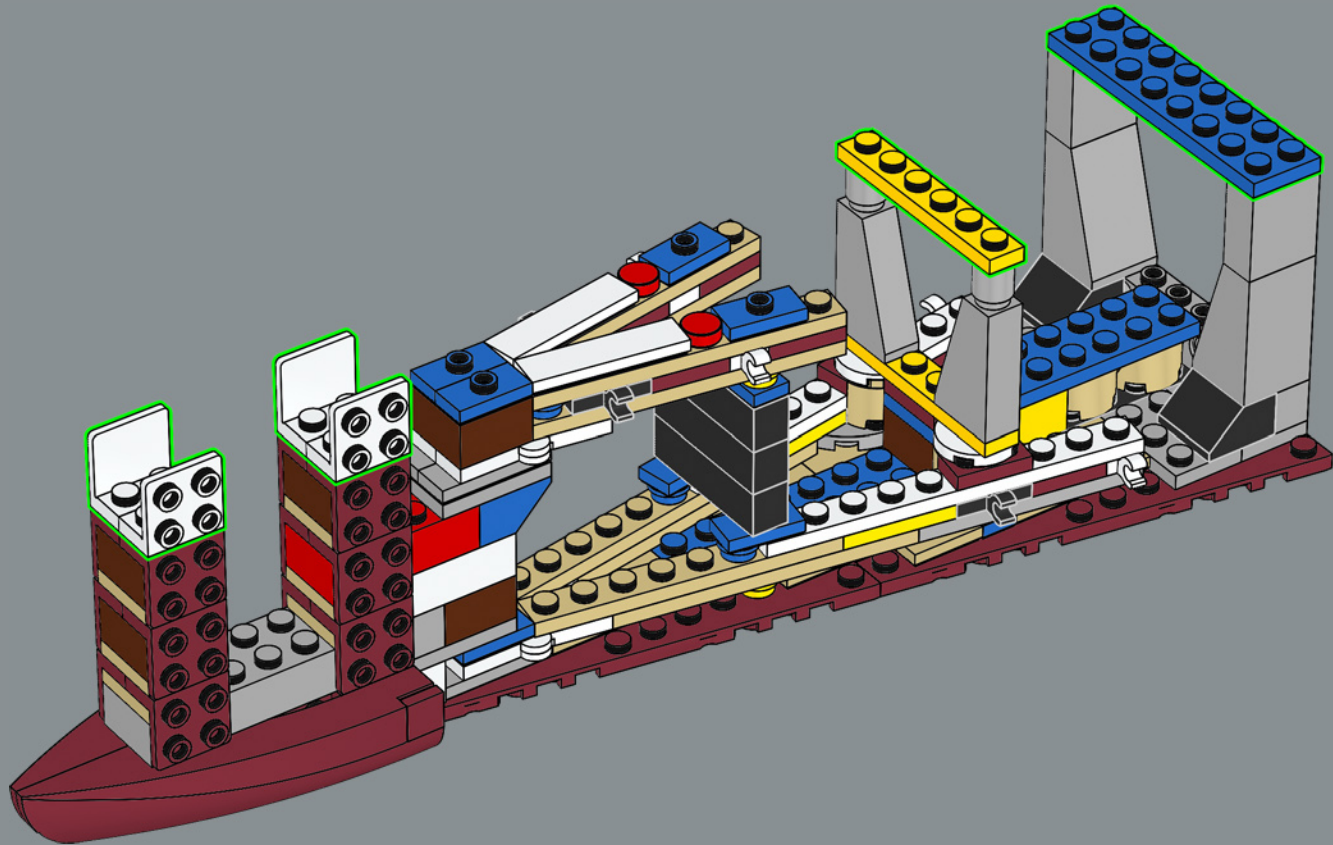

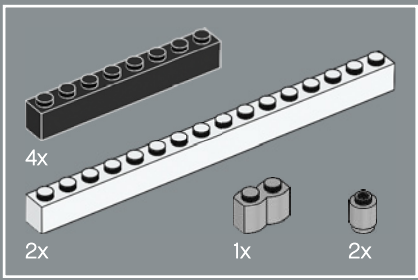

21

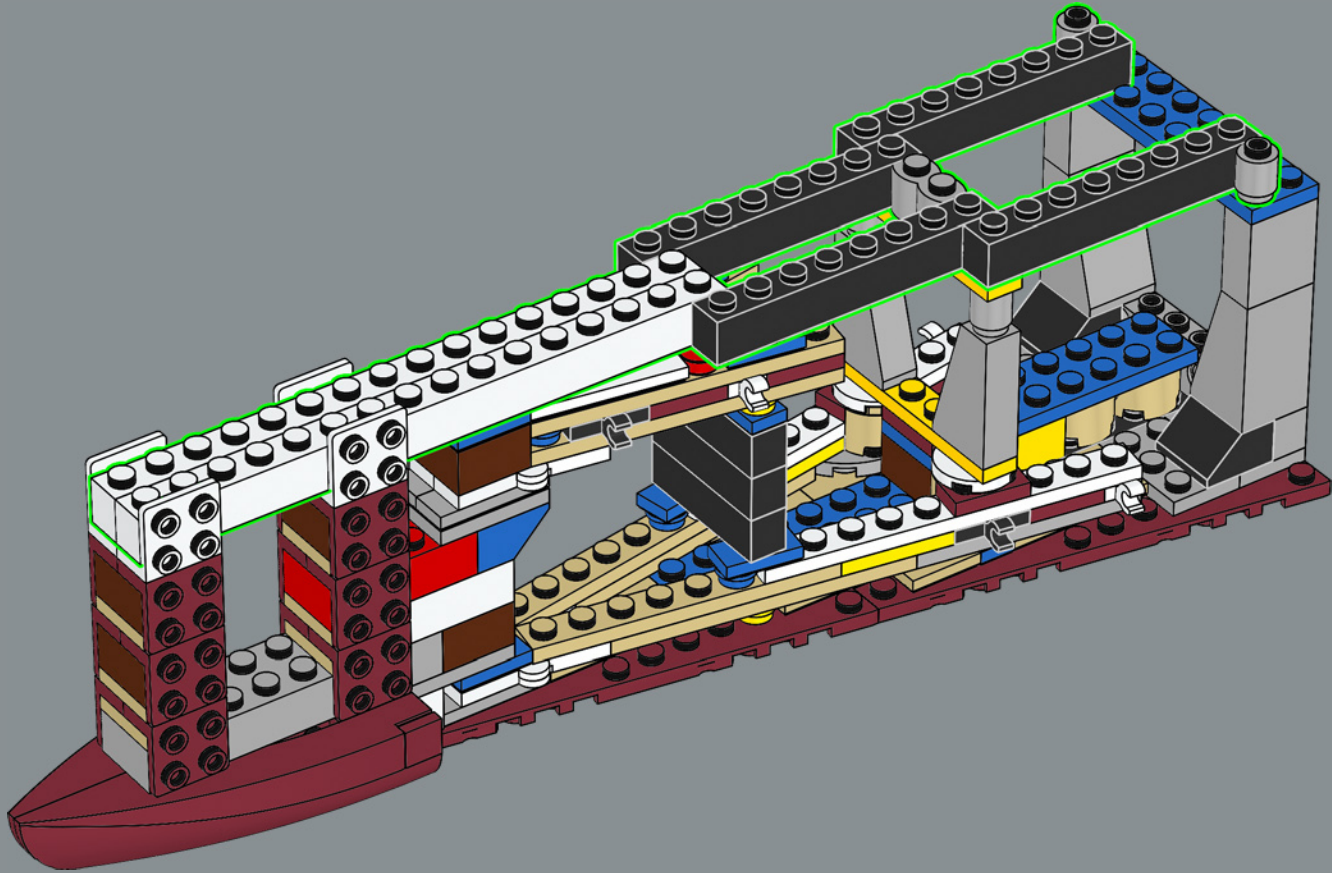

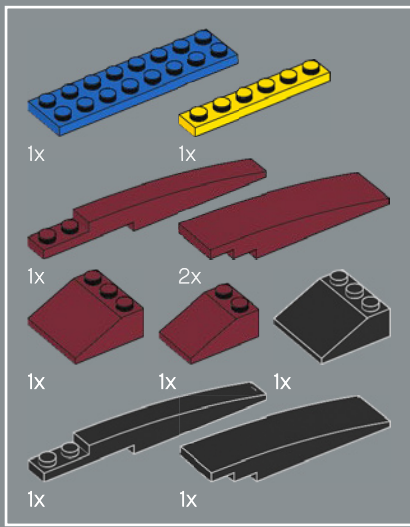

22

1

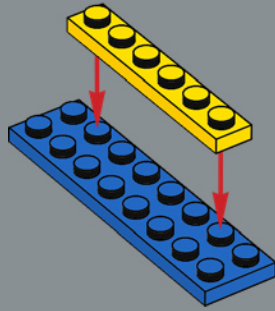

2

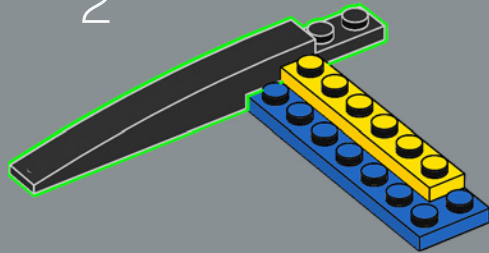

3

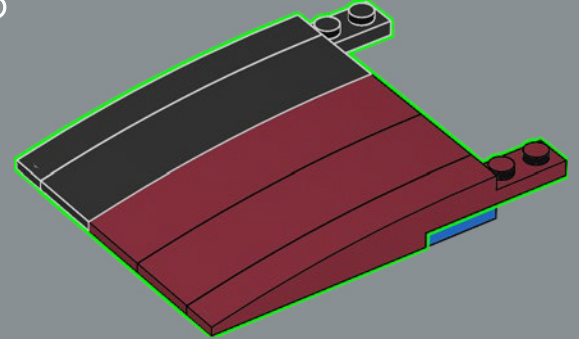

4

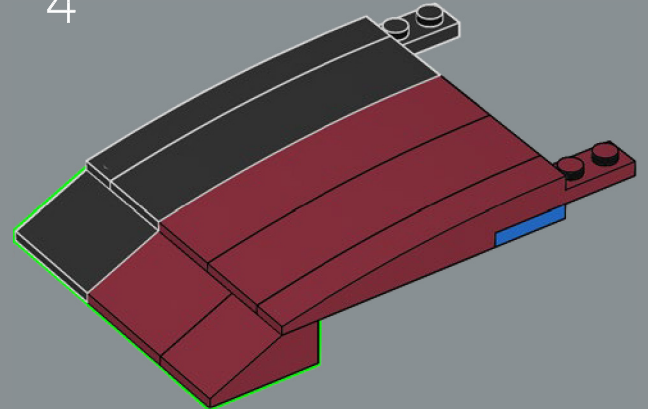

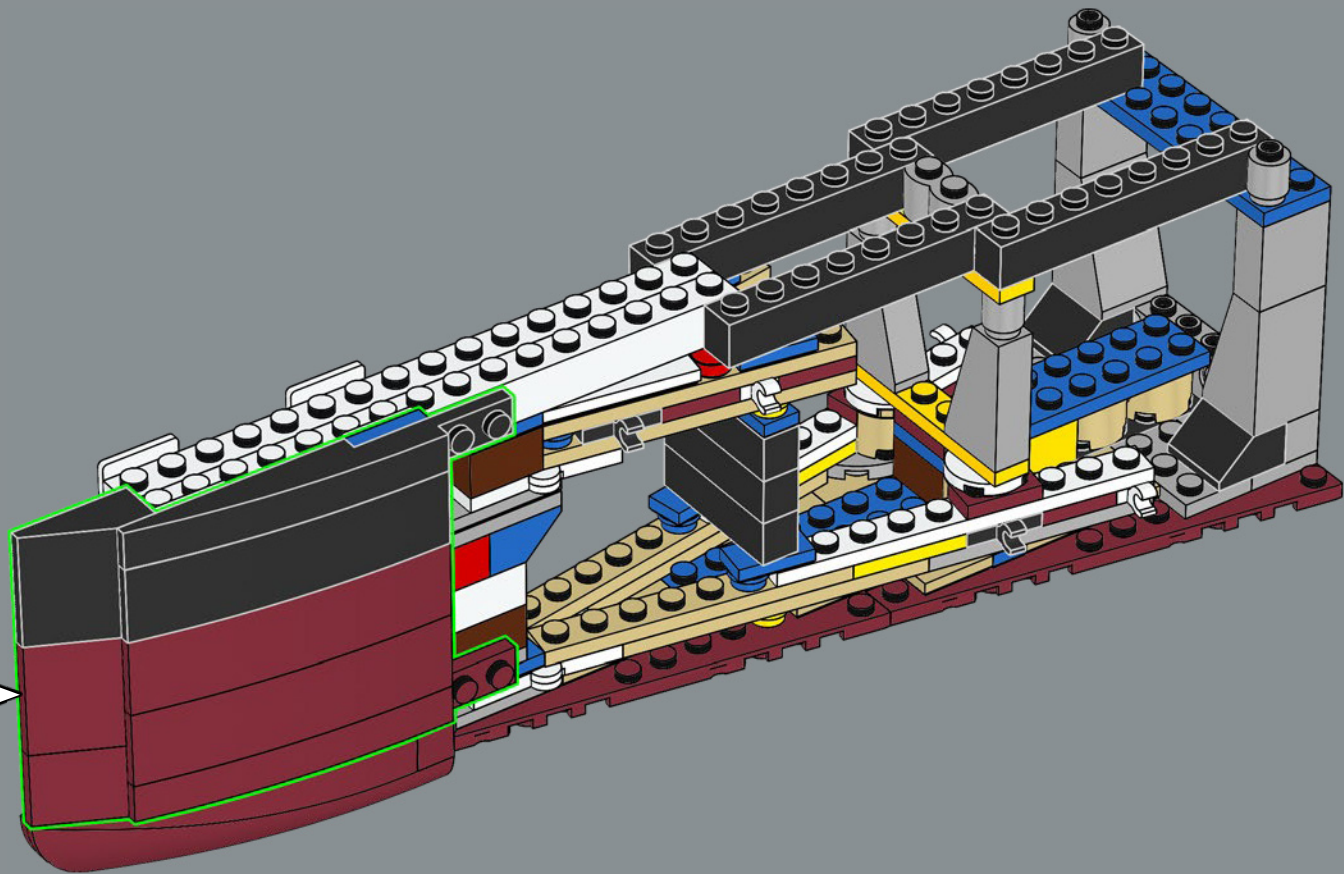

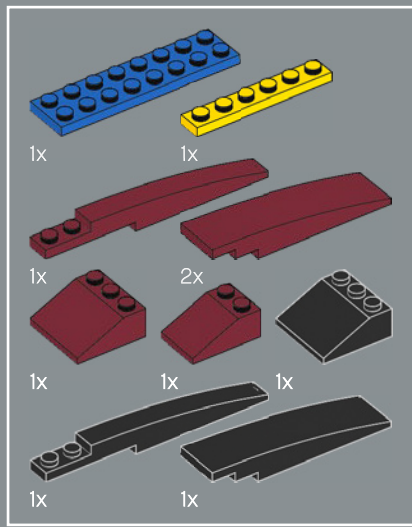

23

1

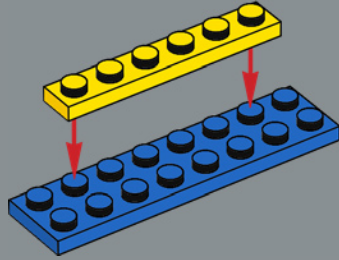

2

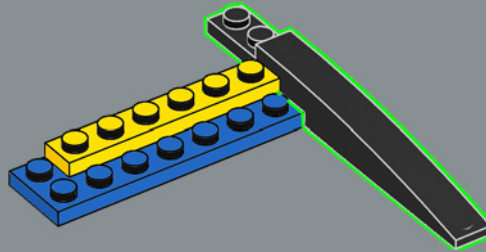

3

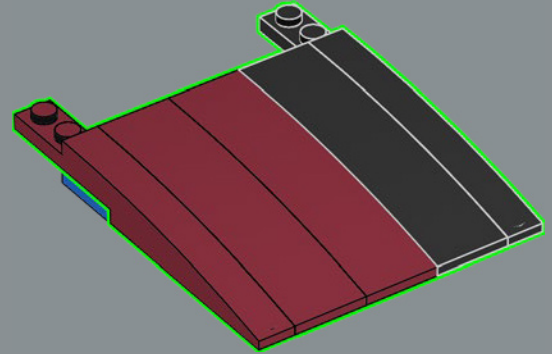

4

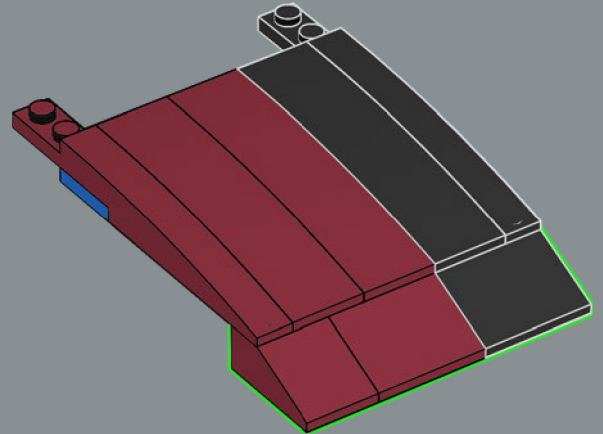

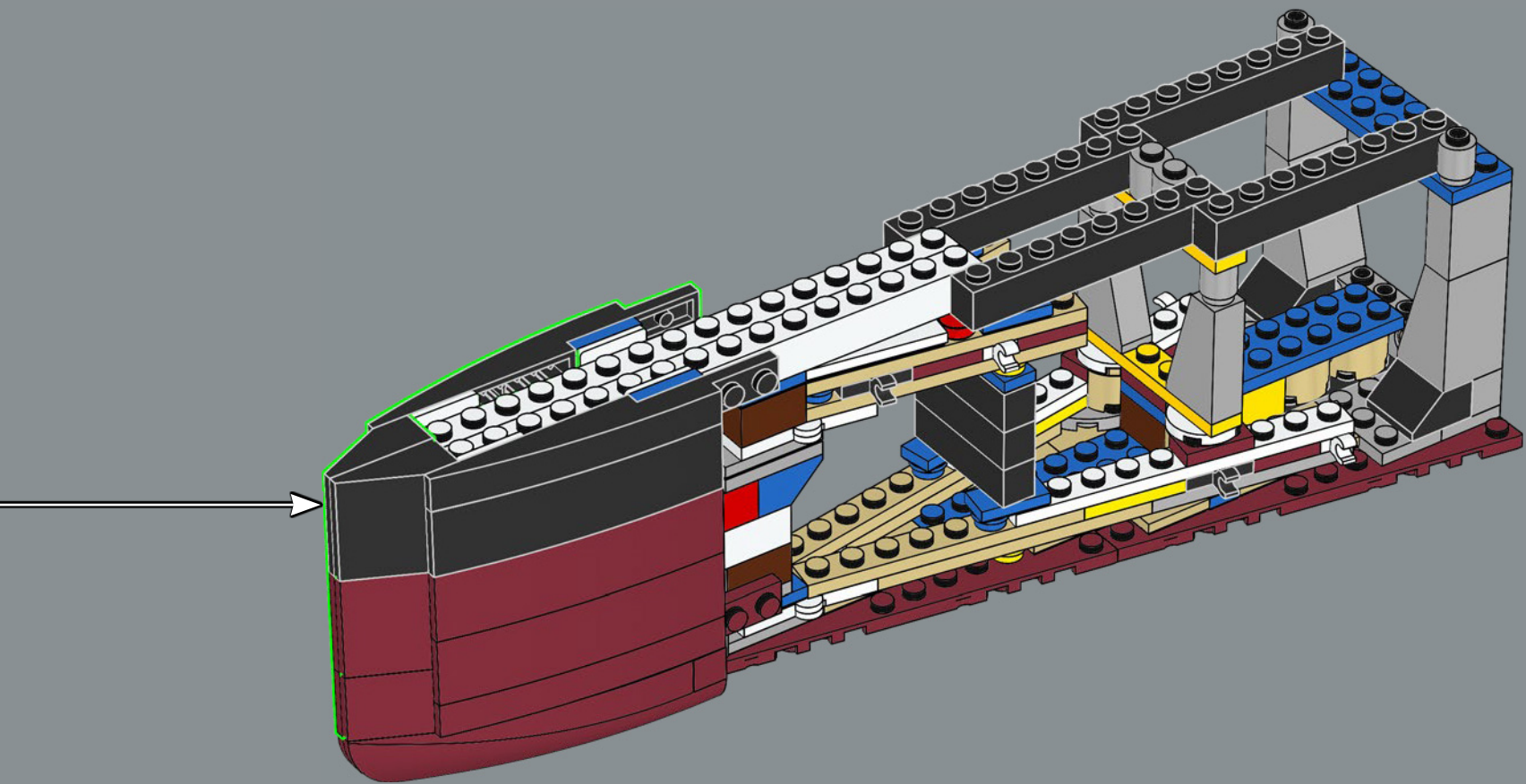



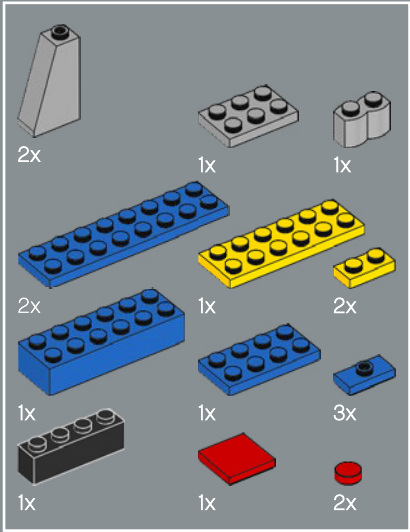
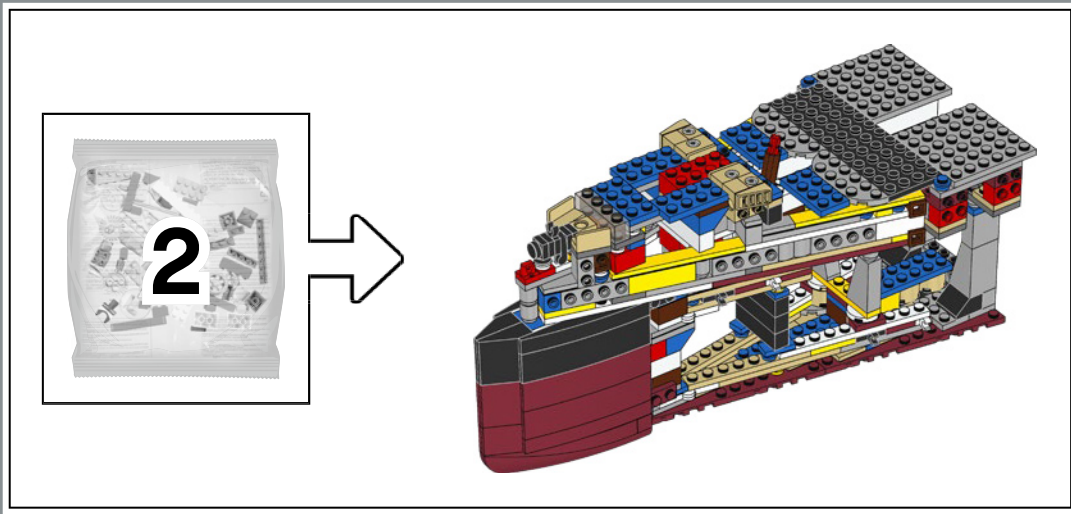

24

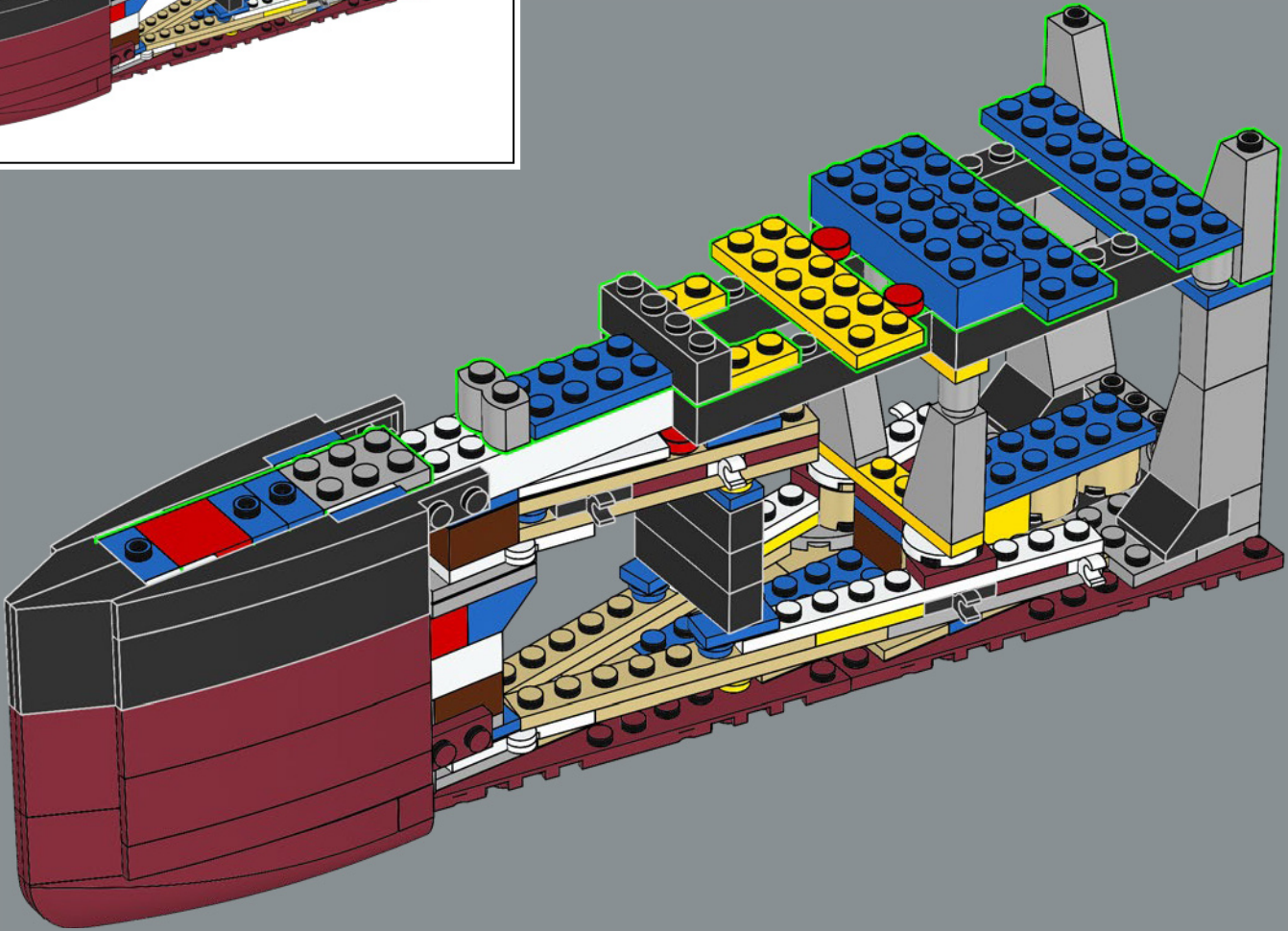

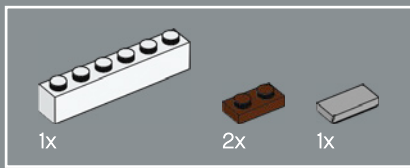

25

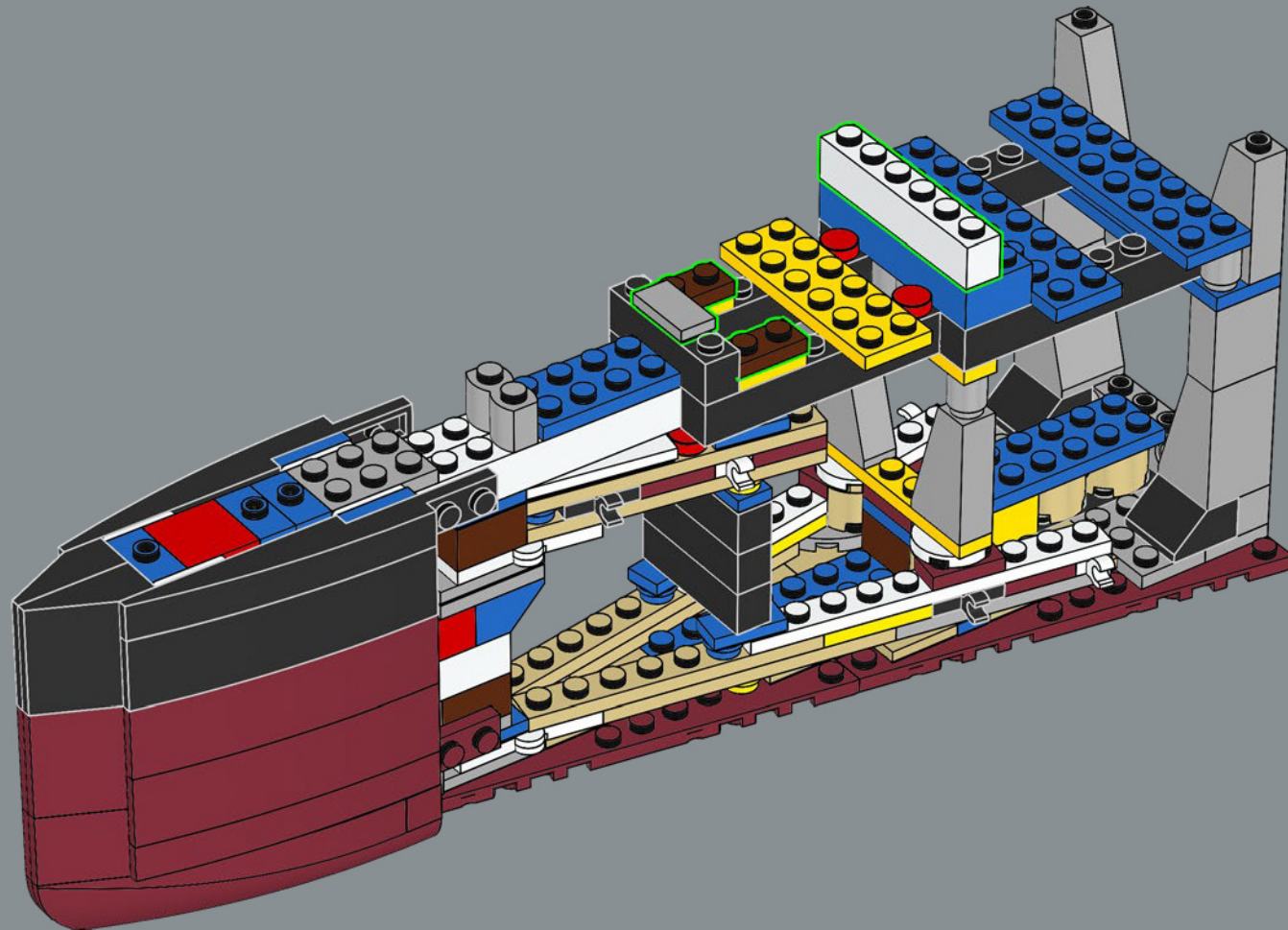

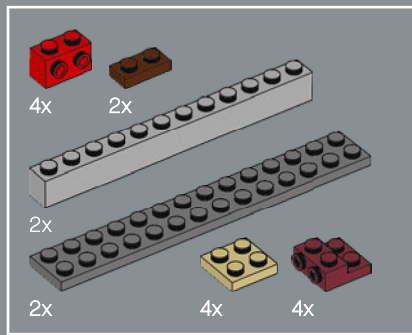

26

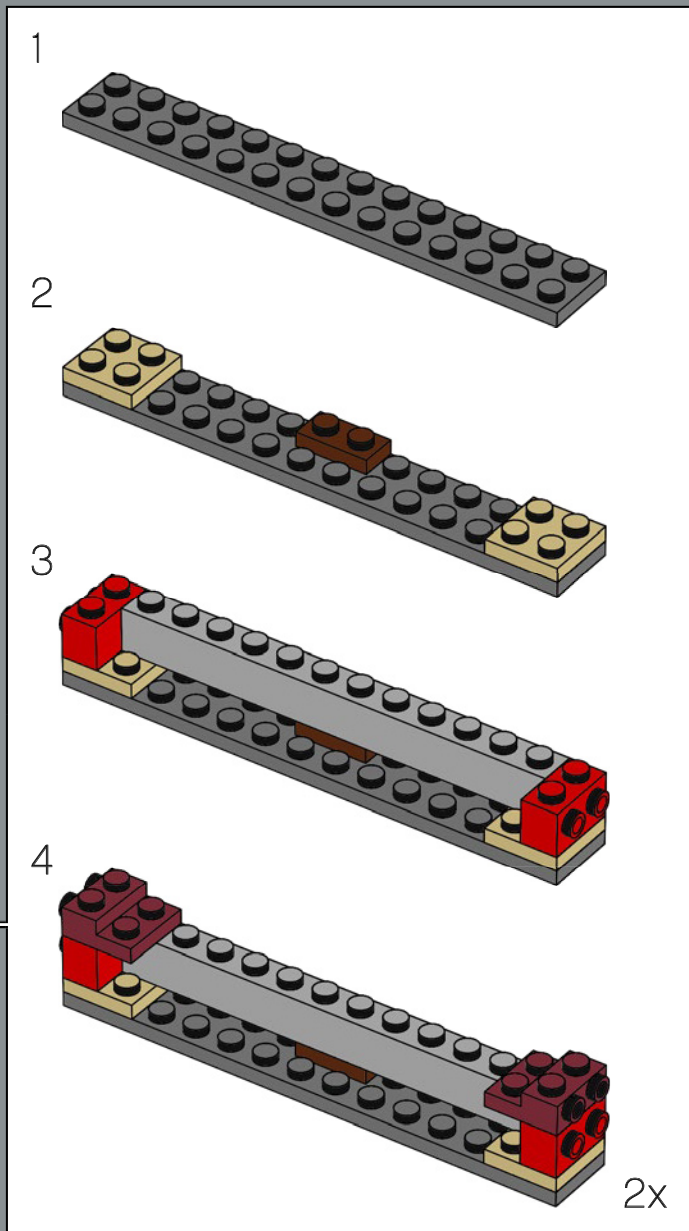
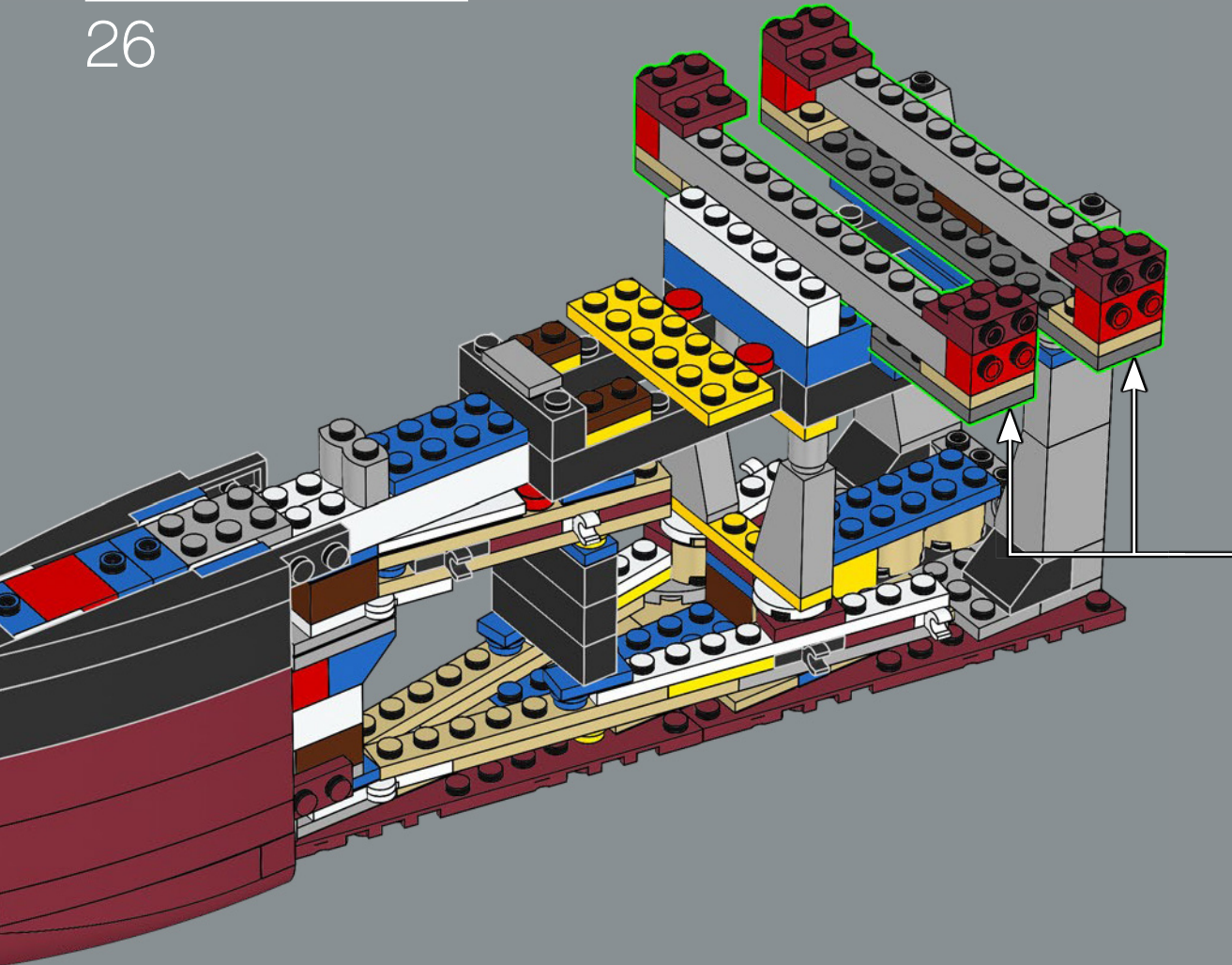

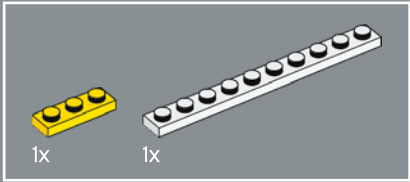
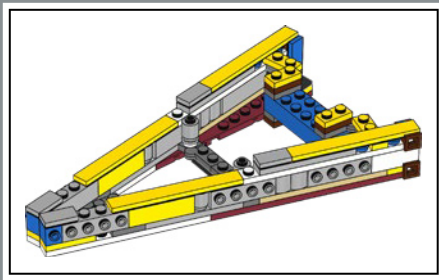

27

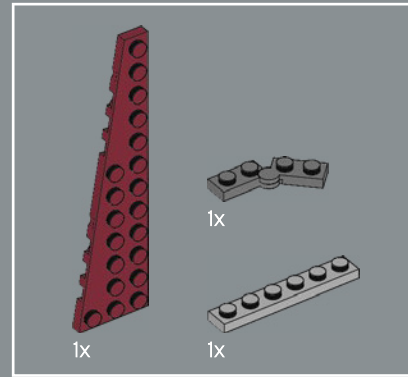
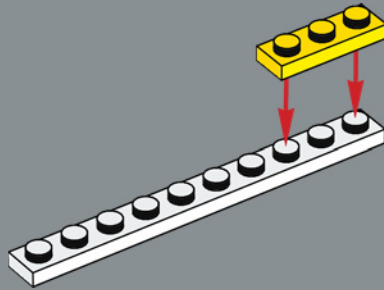

28

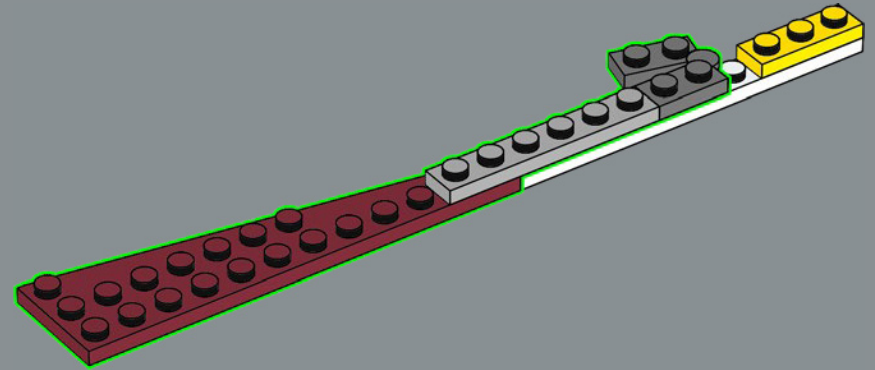

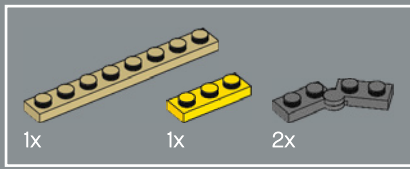

29

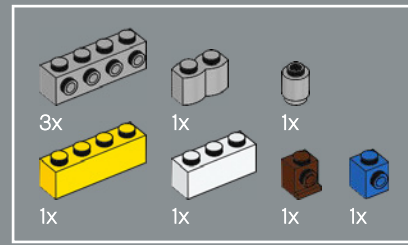
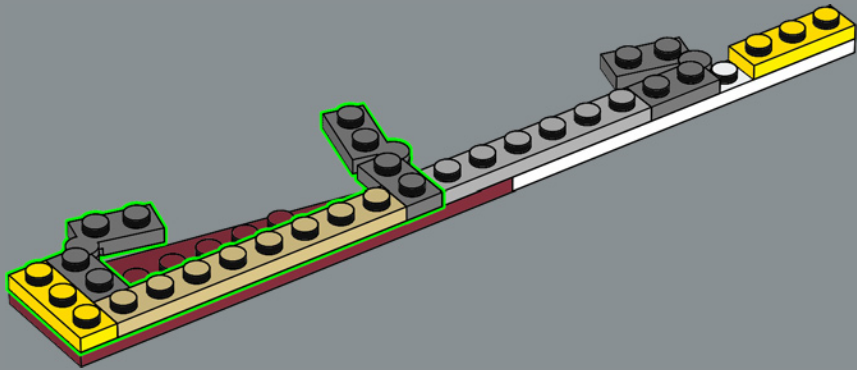

30

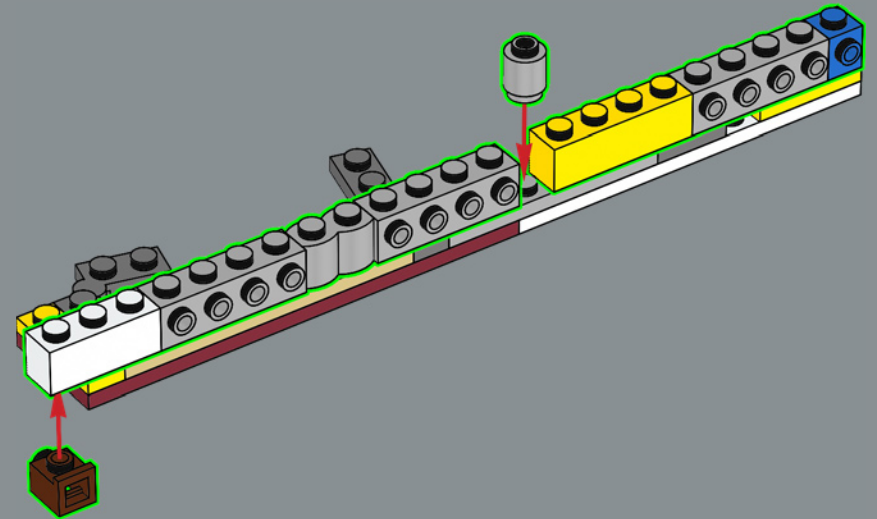



31

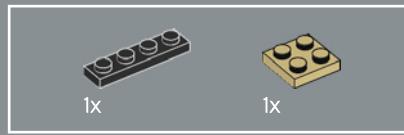
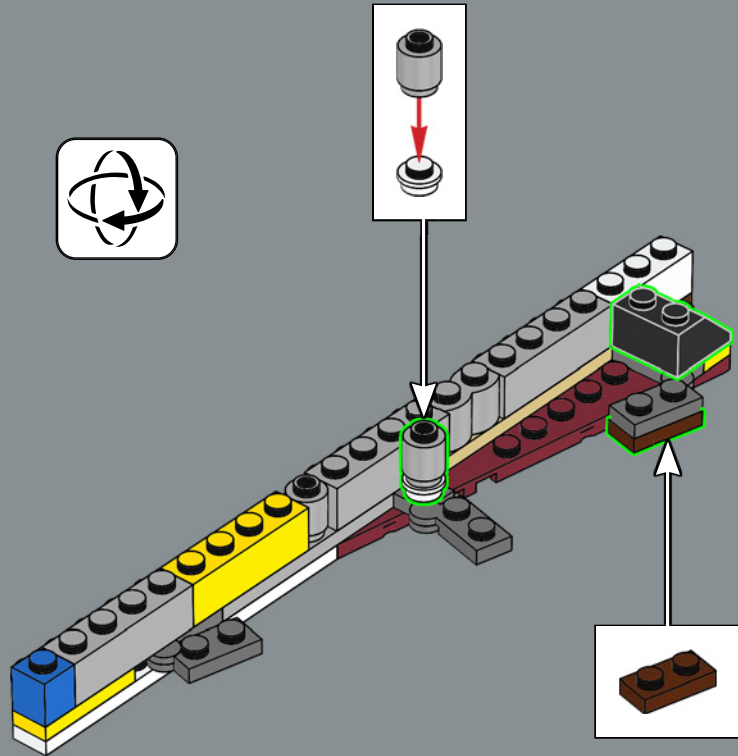

32

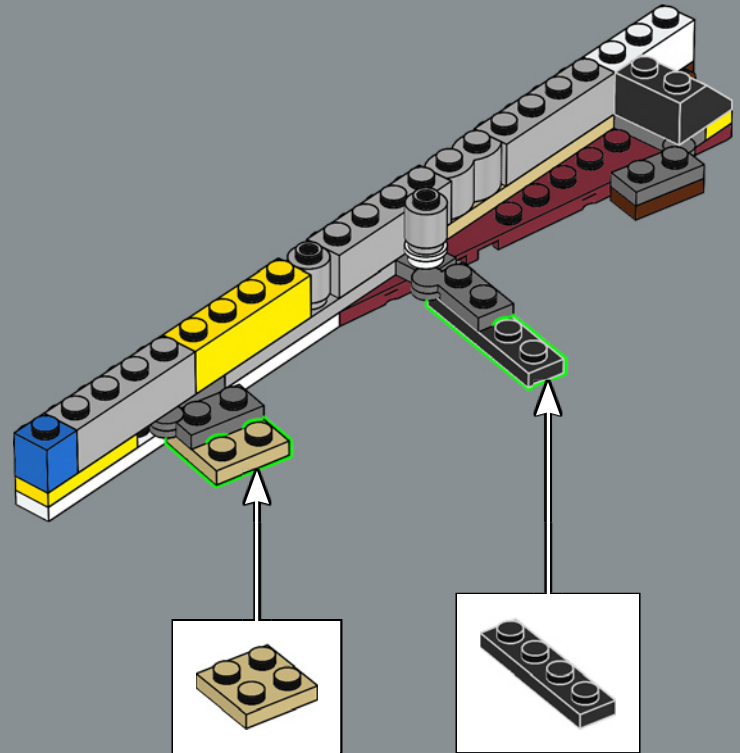

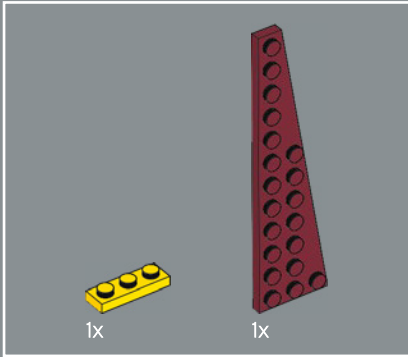
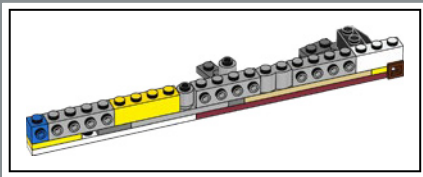

33

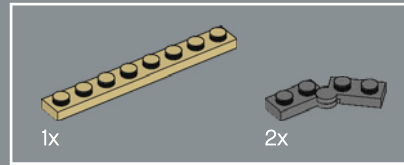
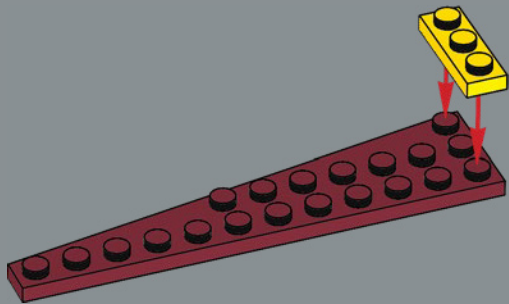

34

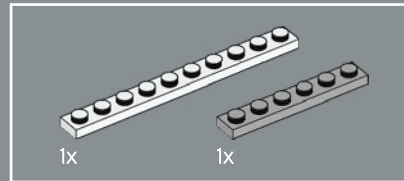
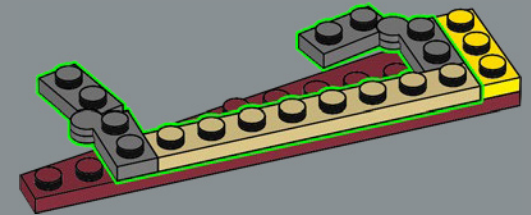

35

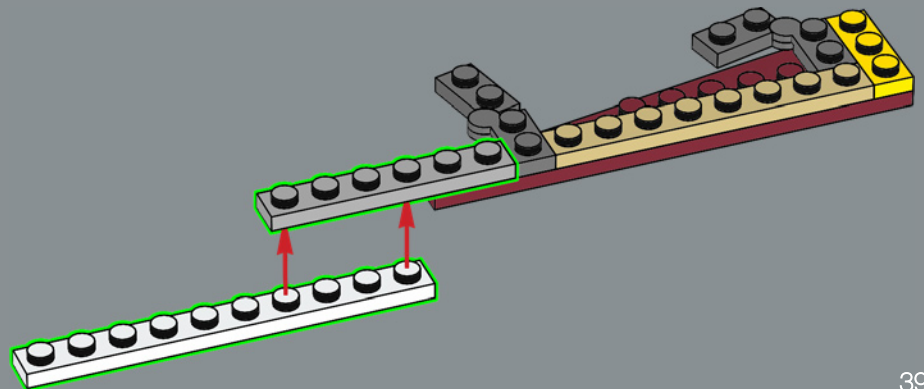

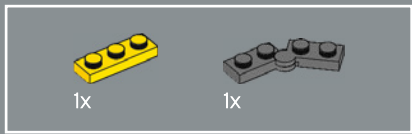

36

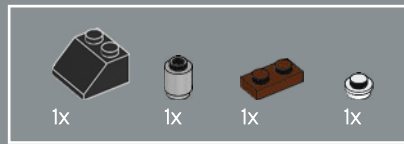
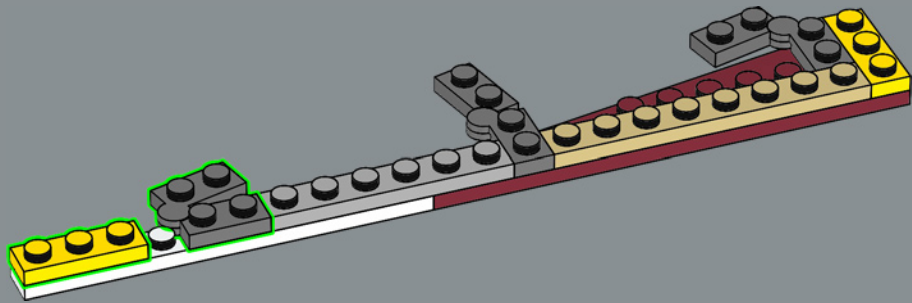

37

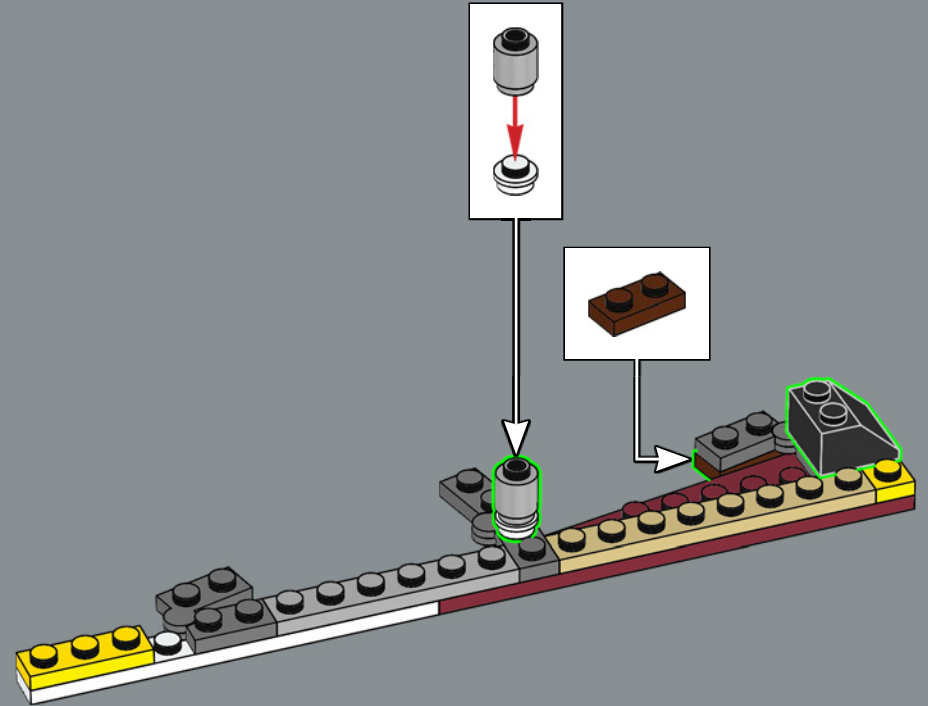



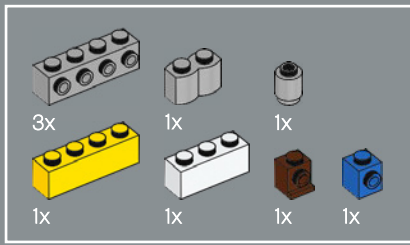

38

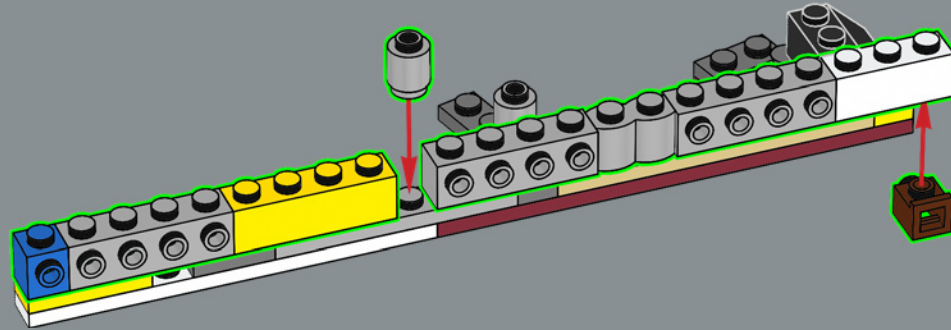

39

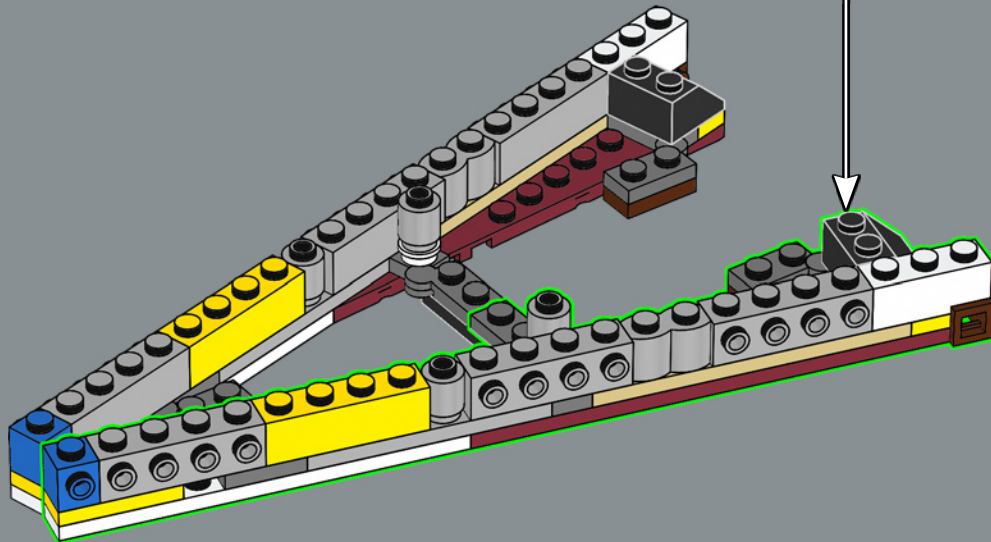

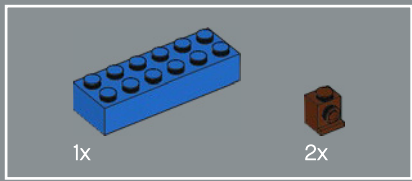

40

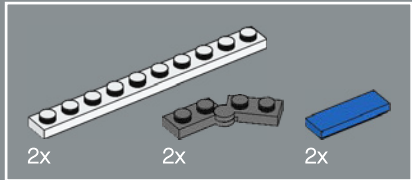
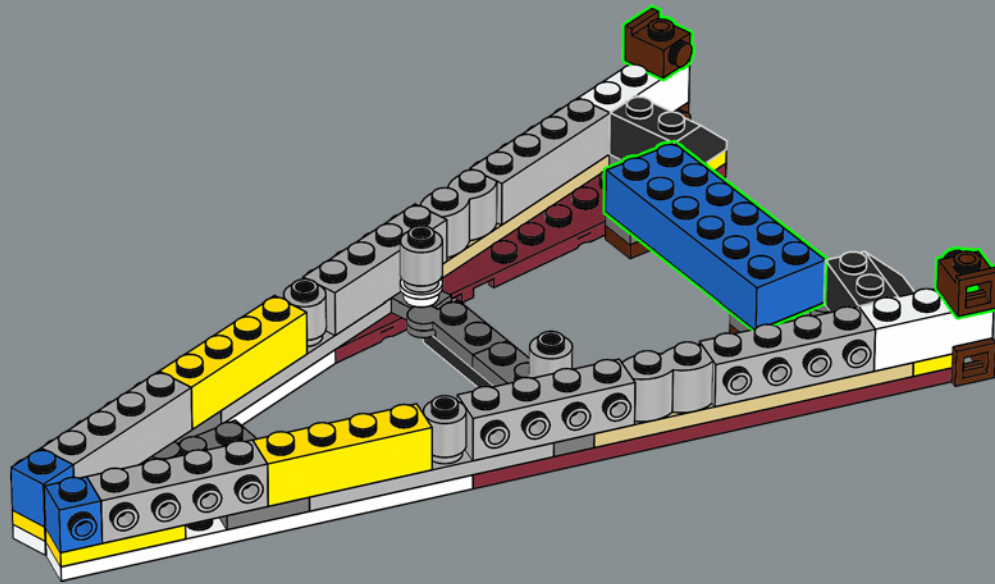

41

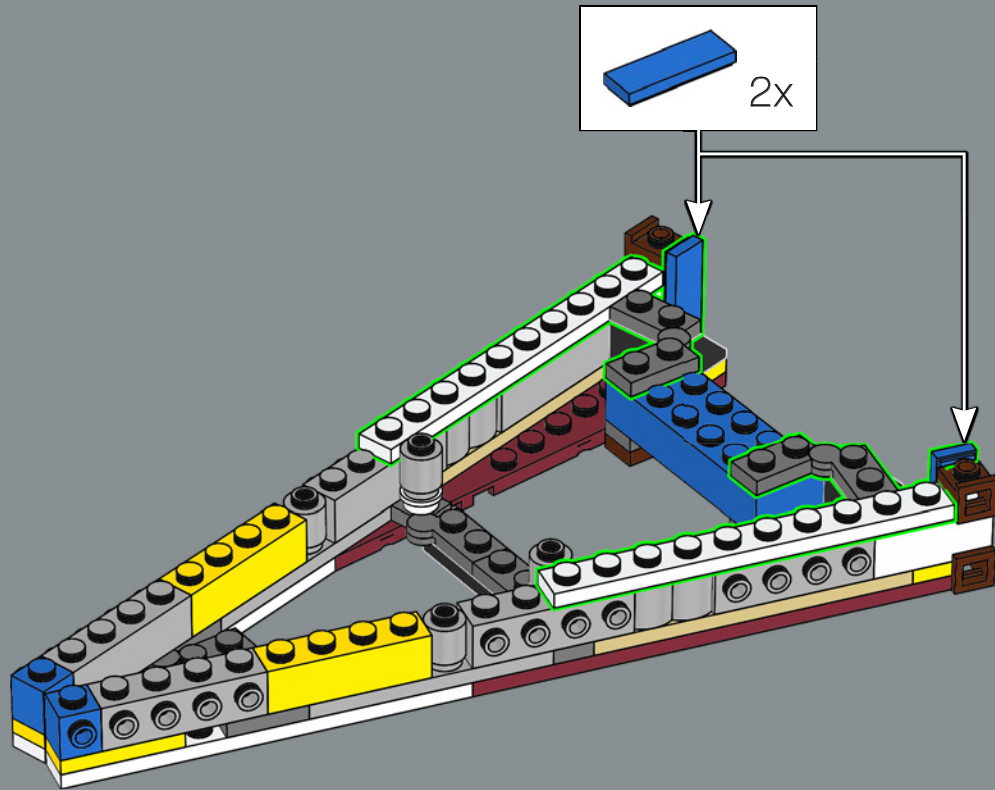

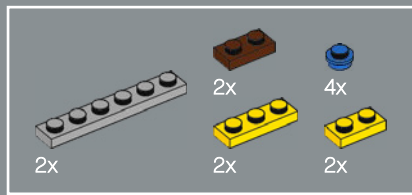

42

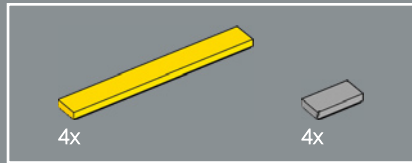
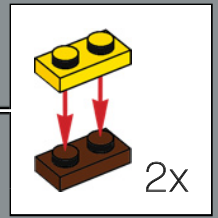
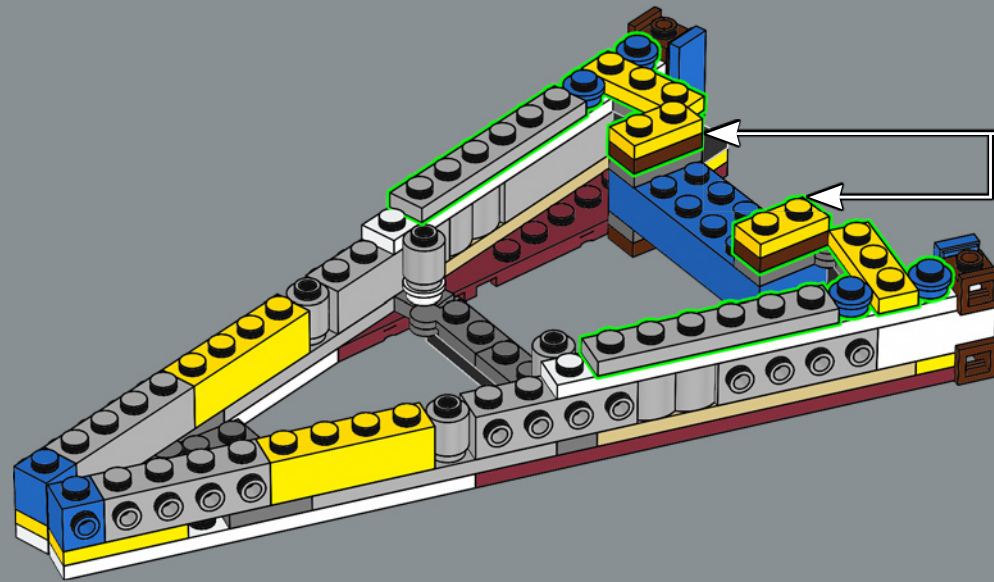

43

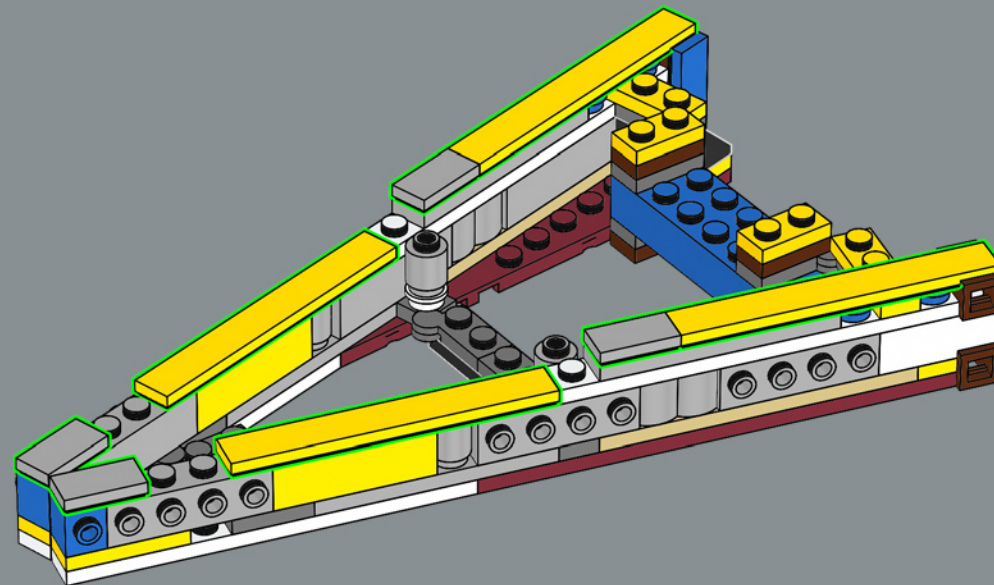

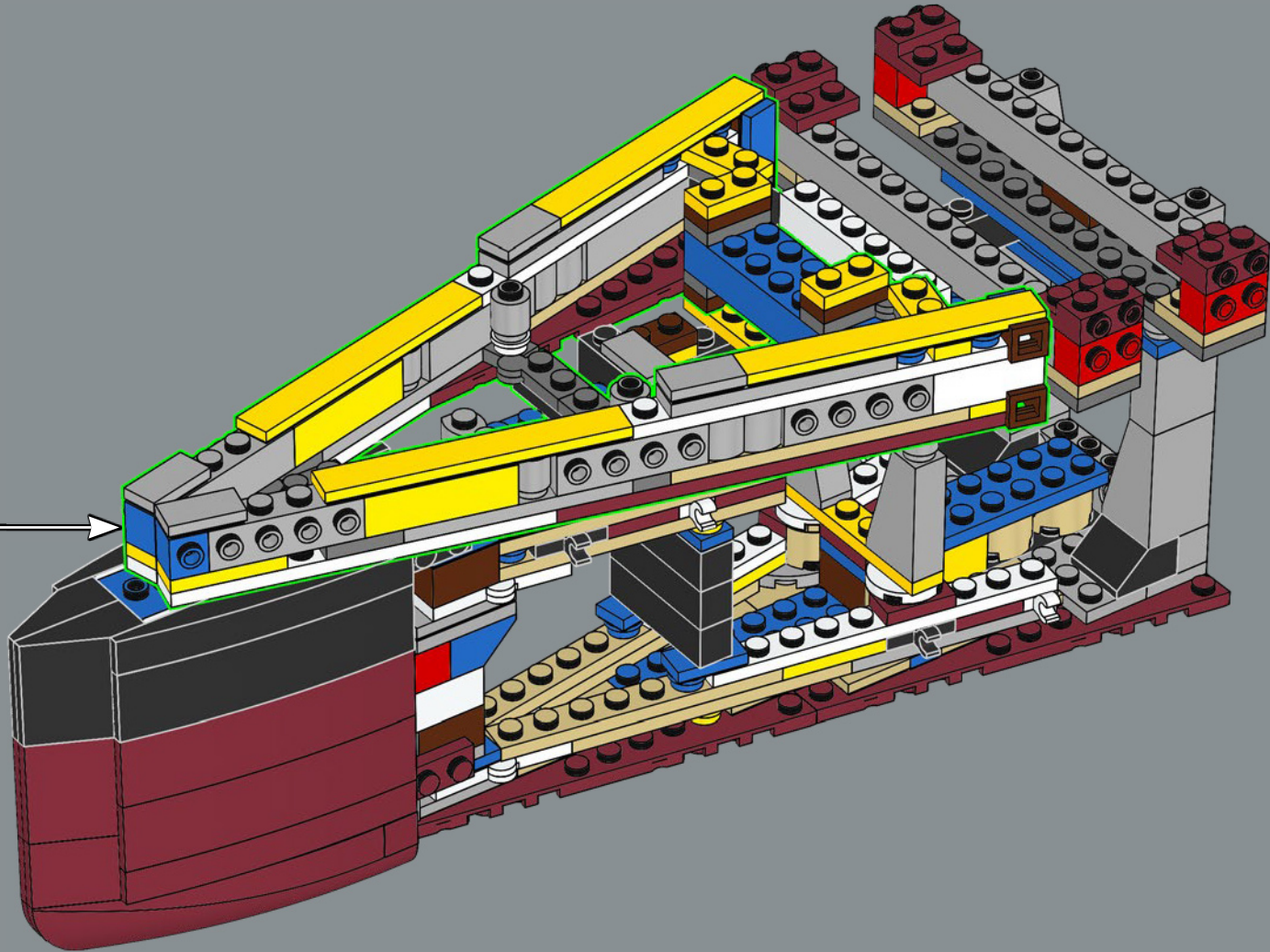

Die *Olympic* und die *Titanic* wurden parallel gebaut. Die Bauzeit beider Schiffe betrug 26 Monate.



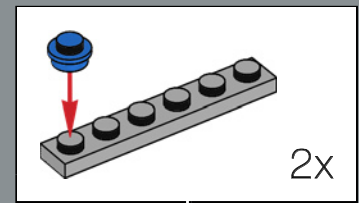
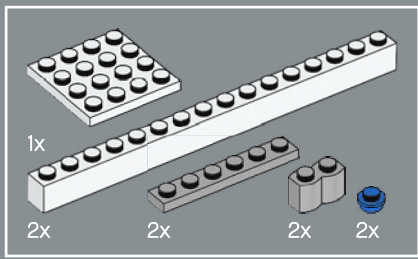

46

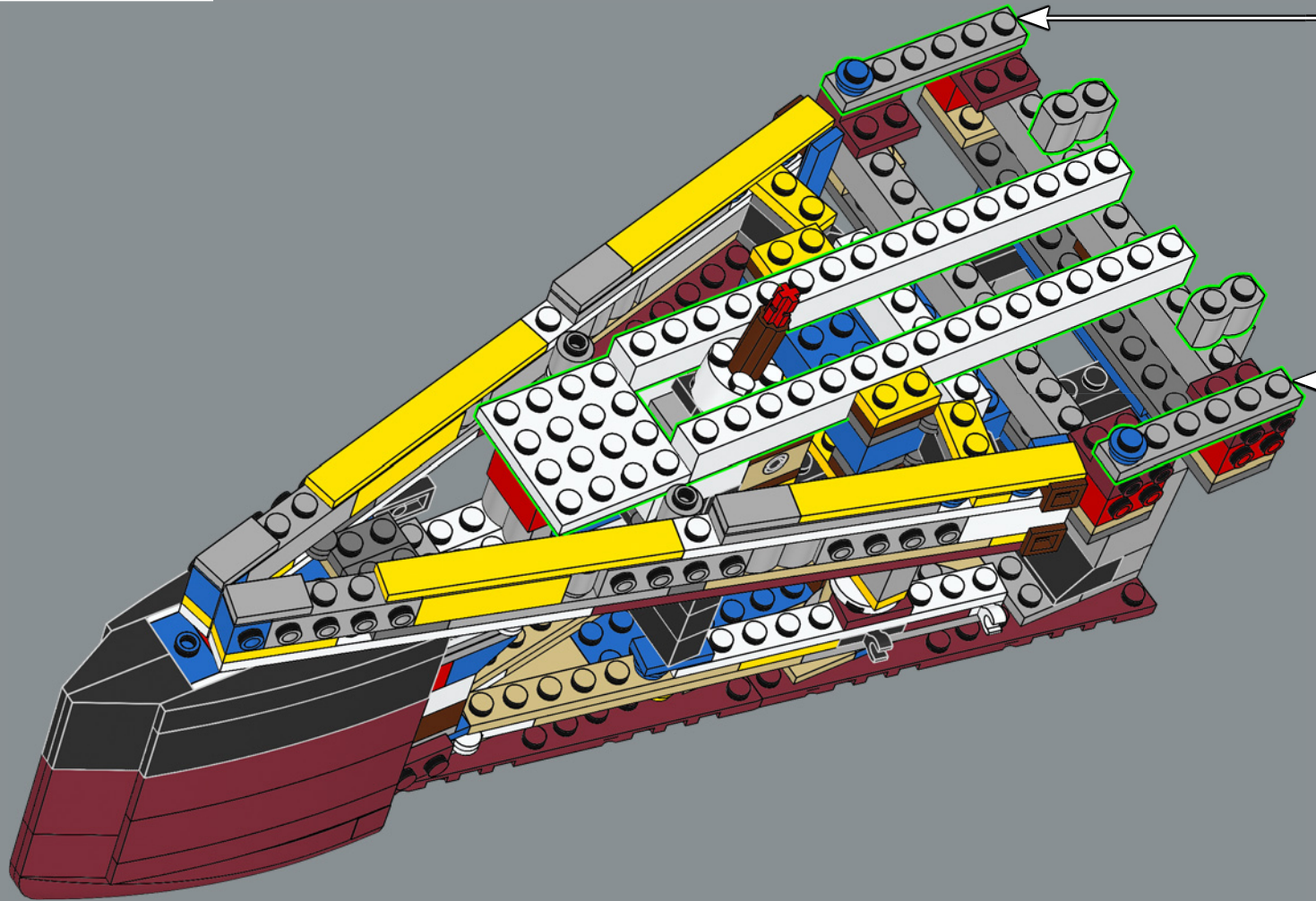

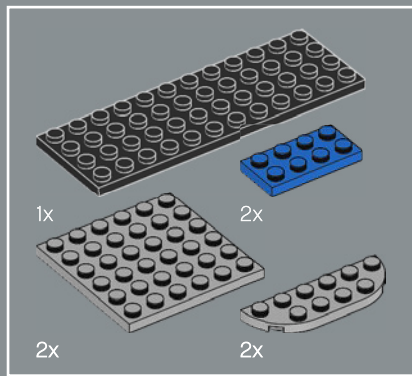

47

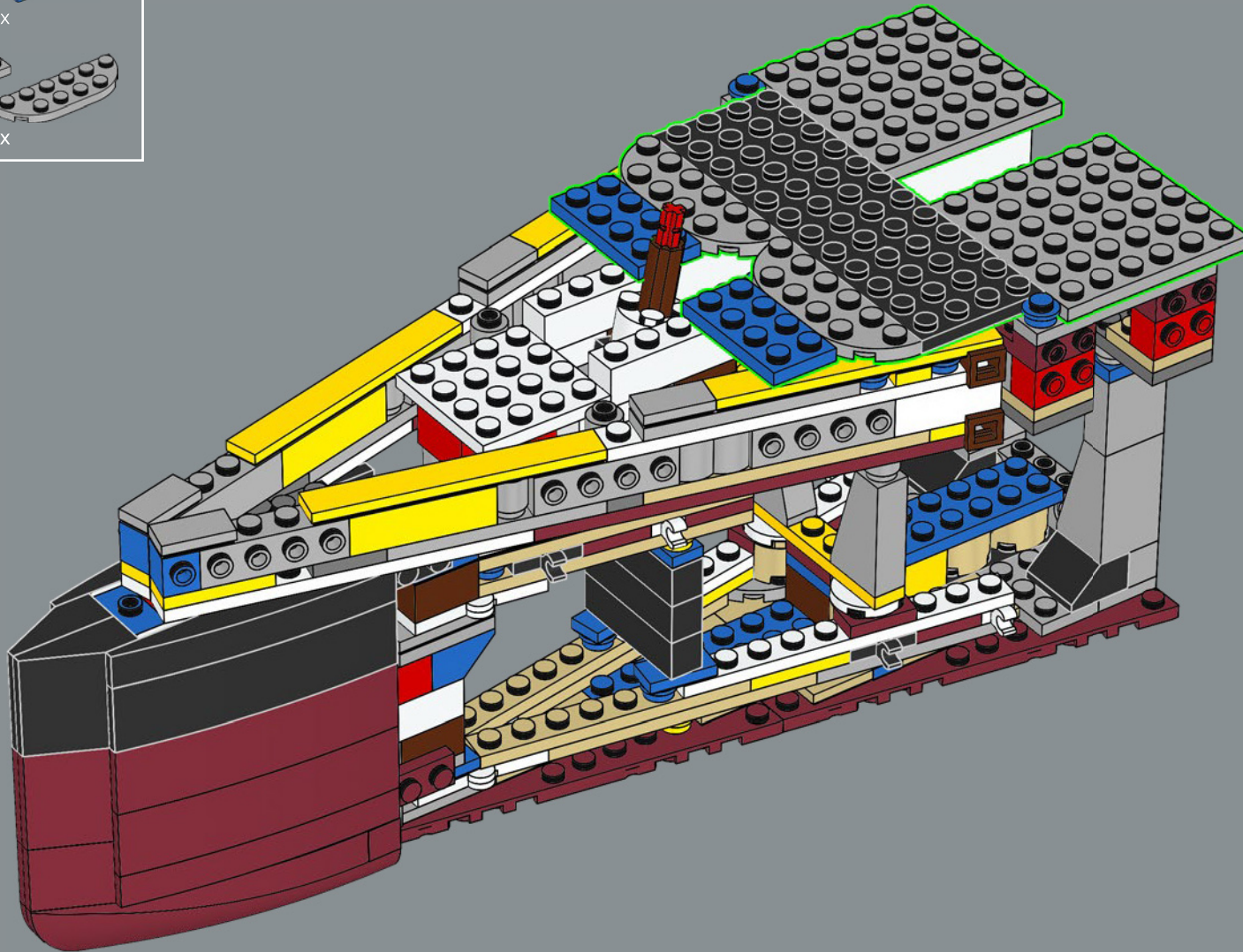

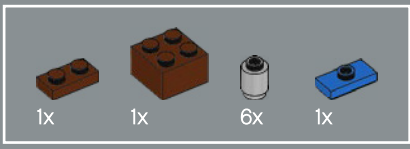

48

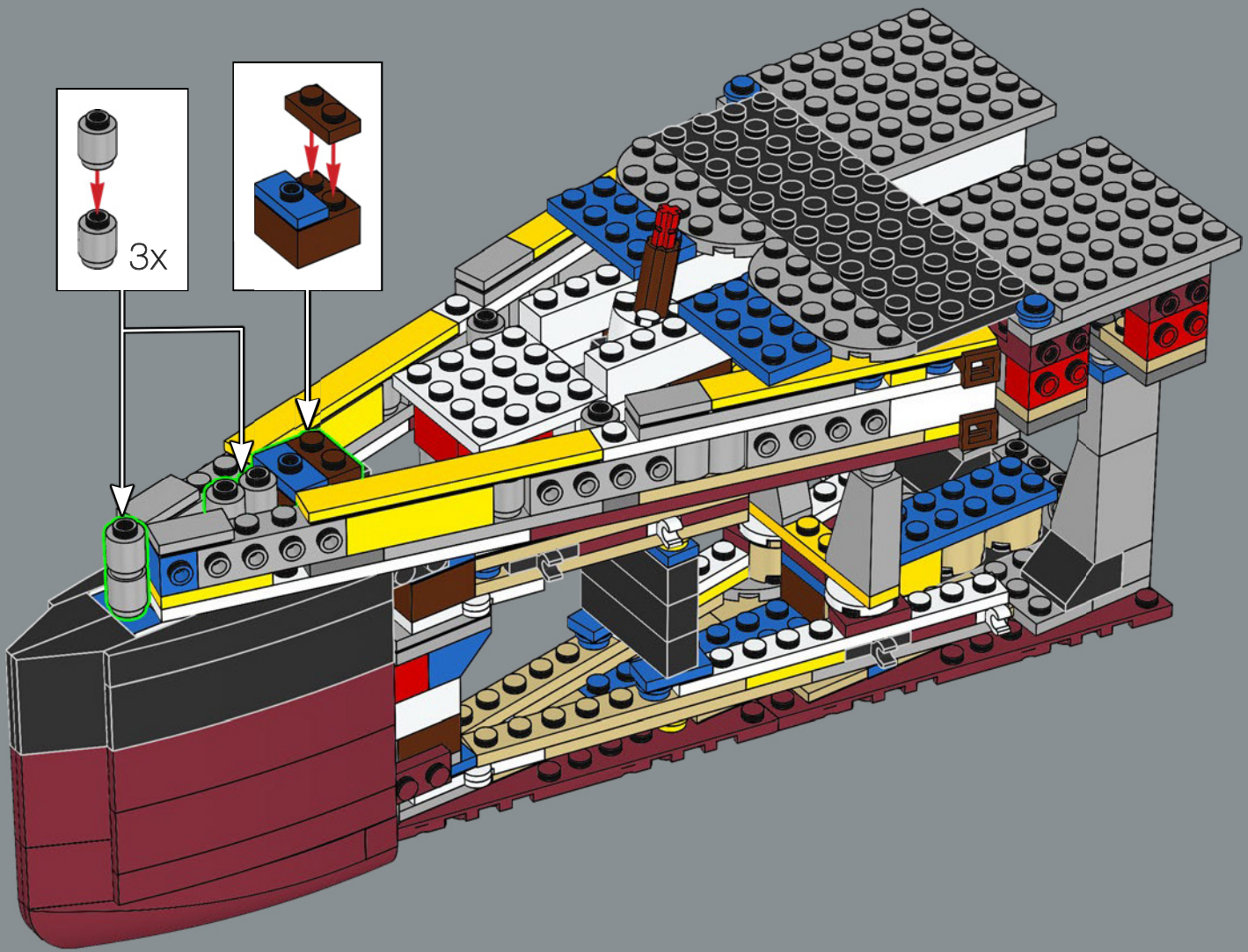



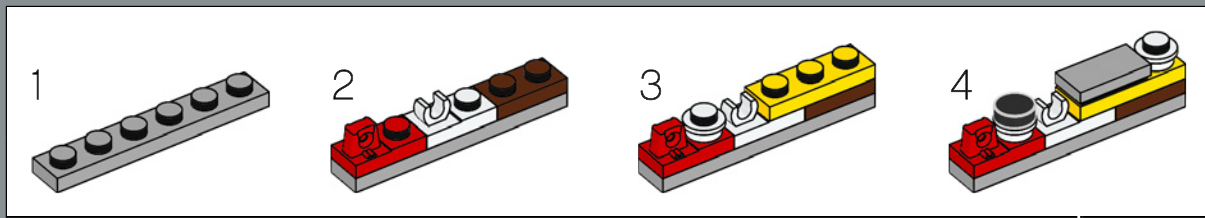
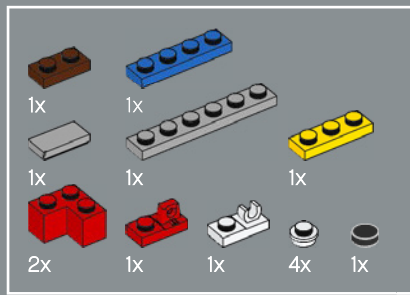

49

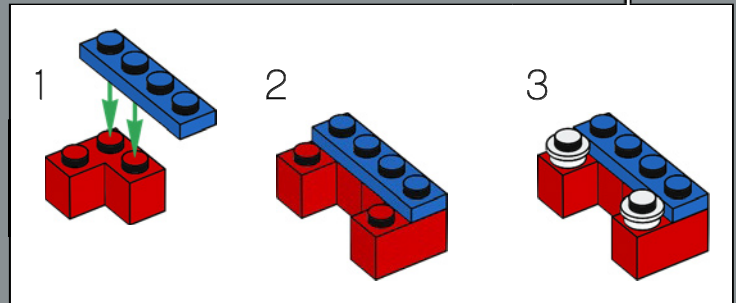
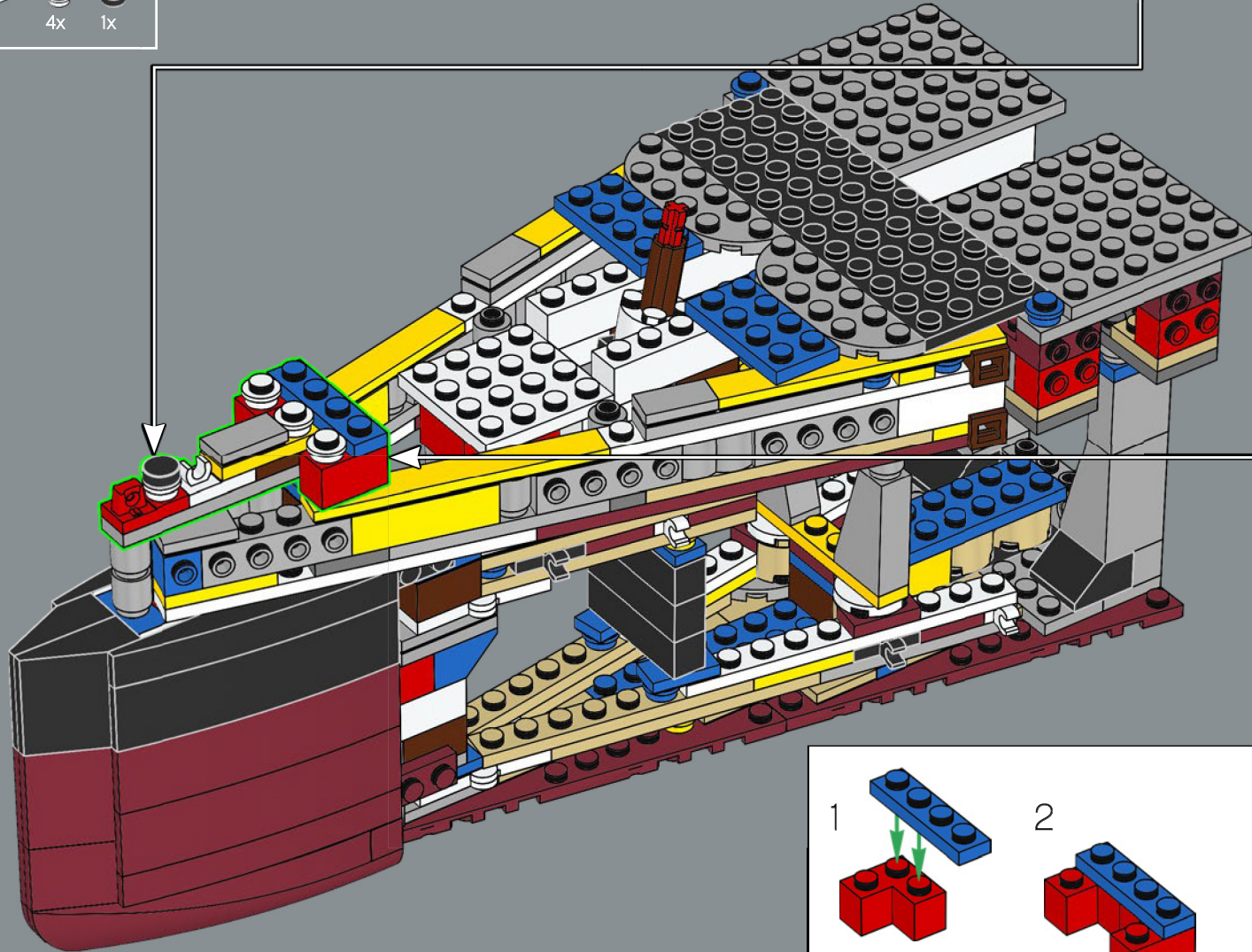

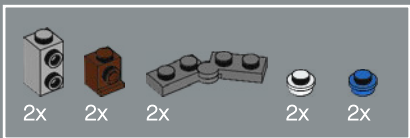

50

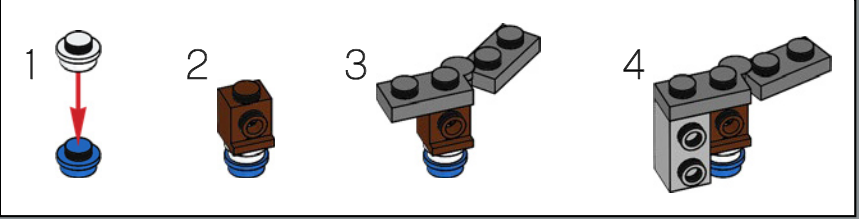
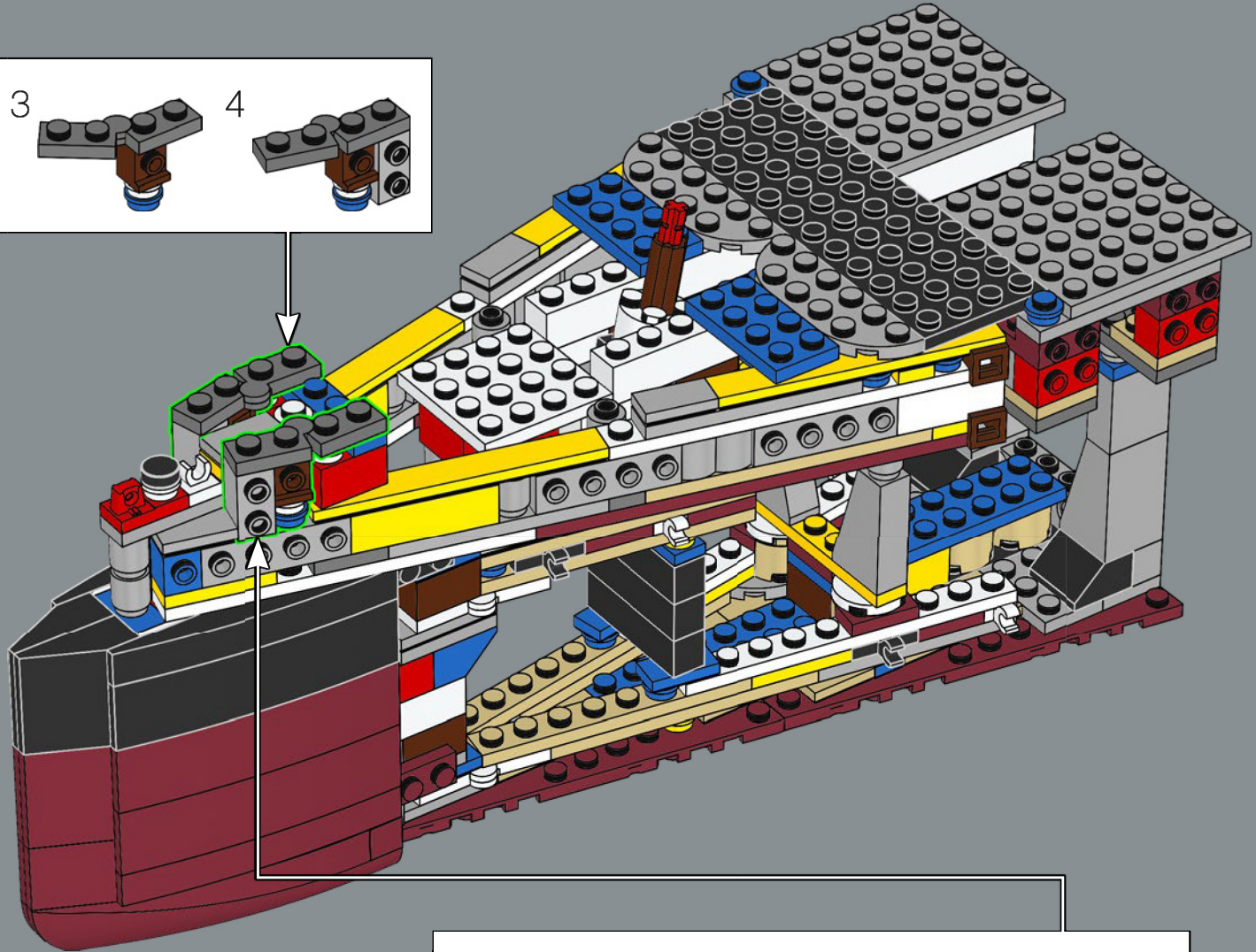
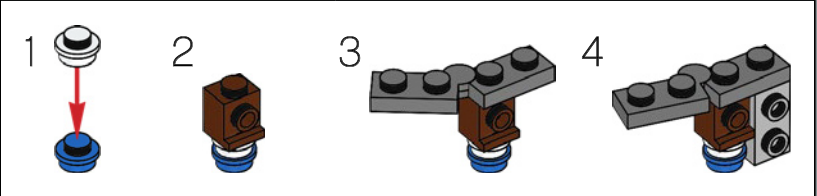

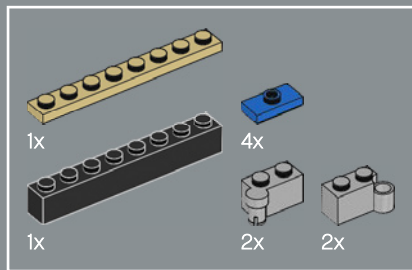

51

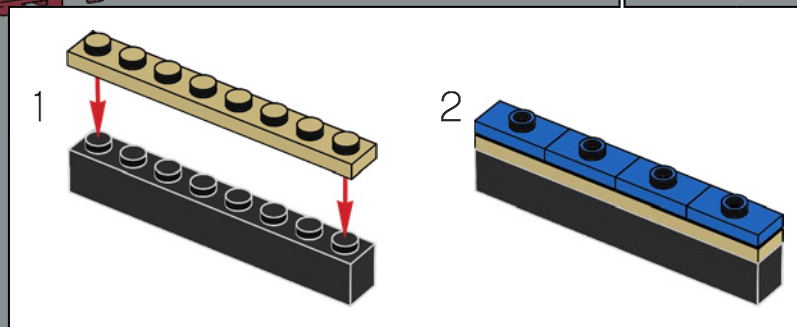
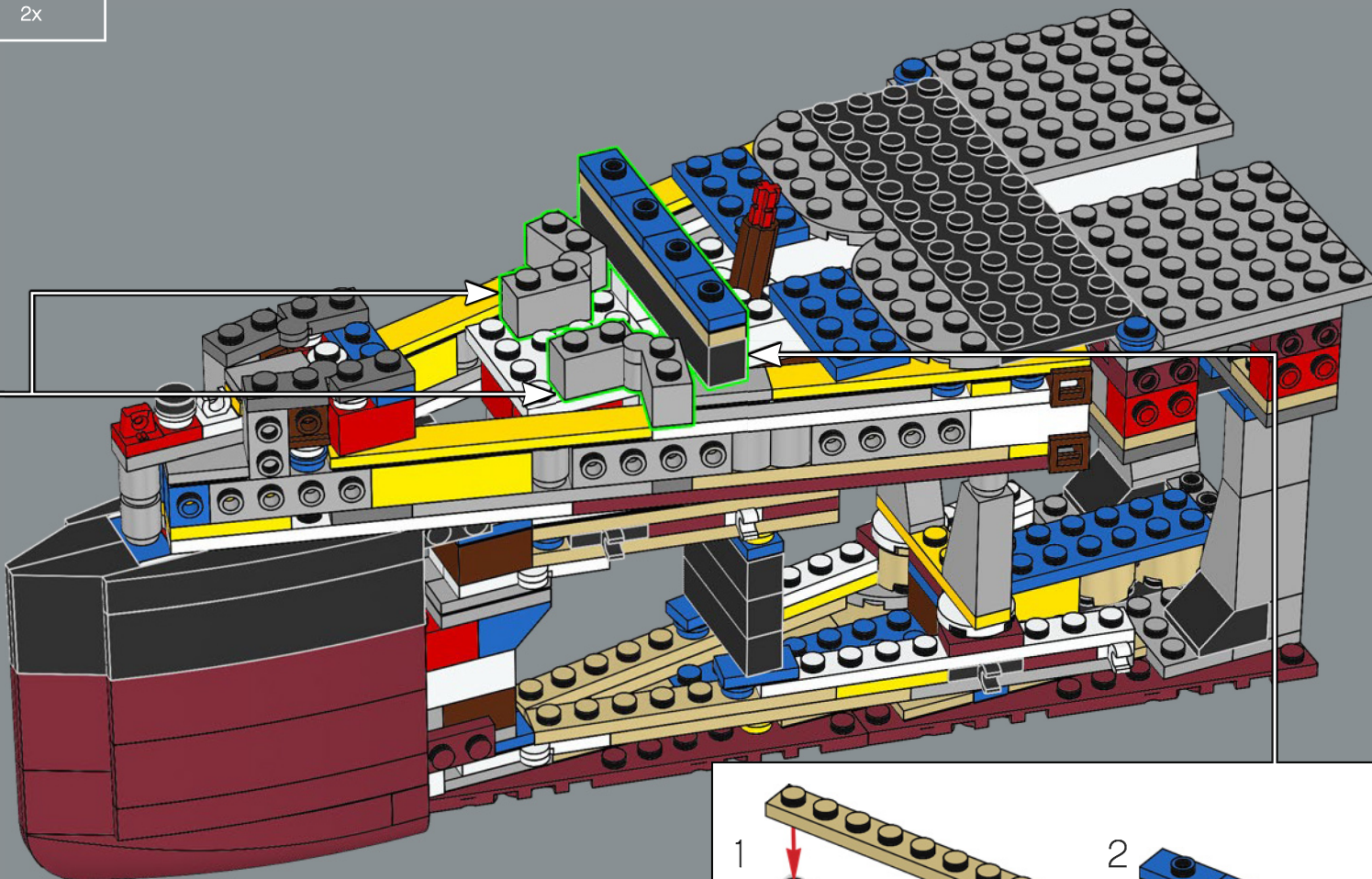
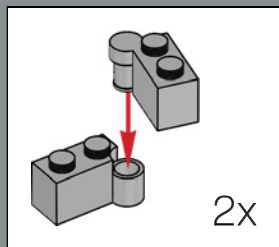

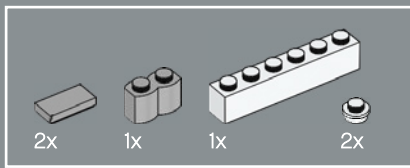

52

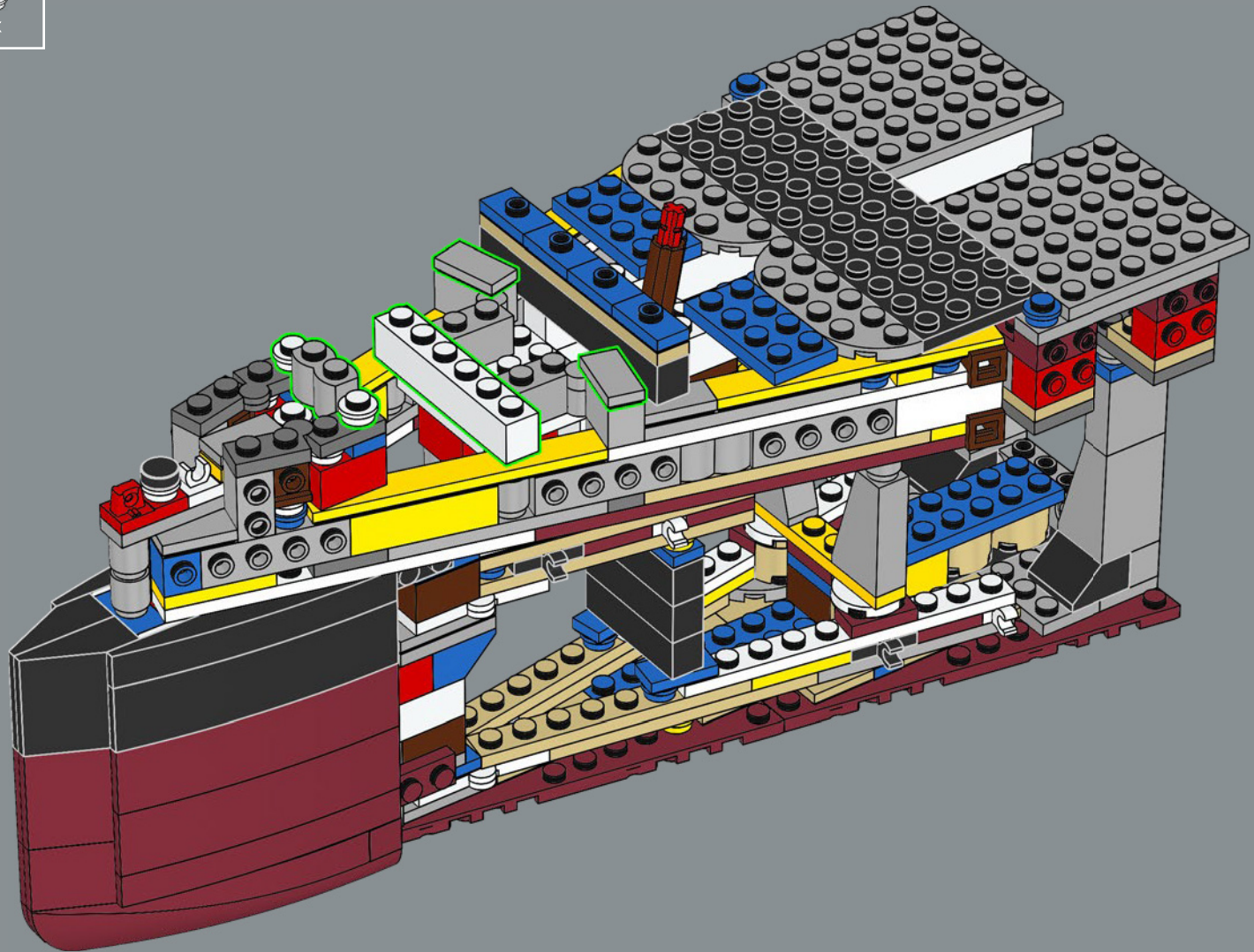

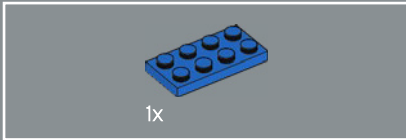
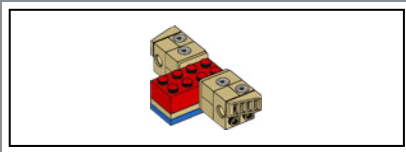

1x

53

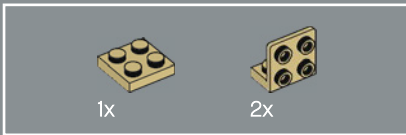
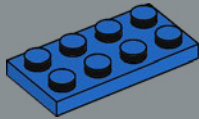

1x

2x

54

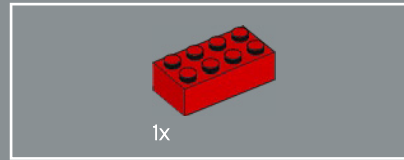
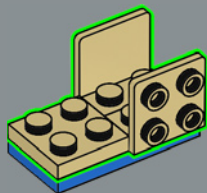

1x

55

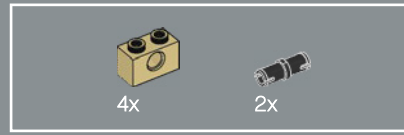
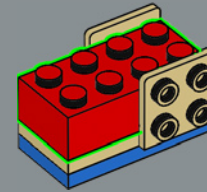

4x

2x

56

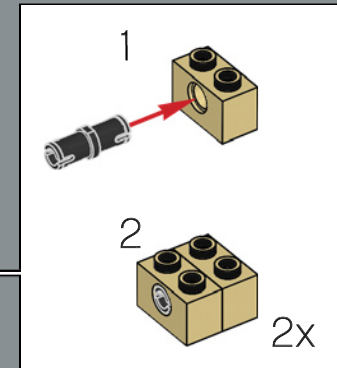

1

2

2x

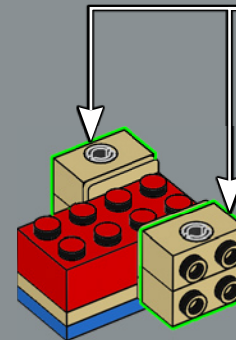

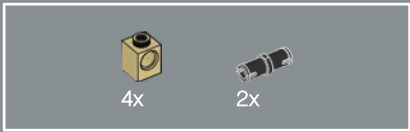

57

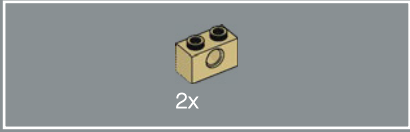
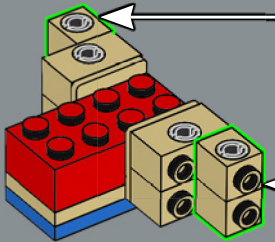
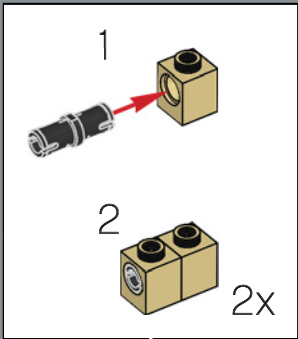

58

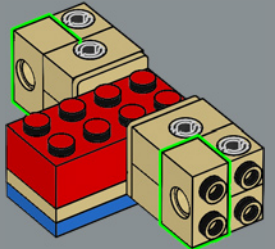

59

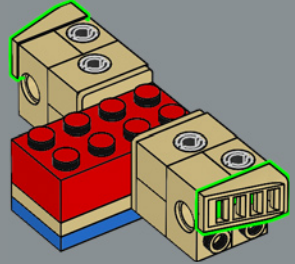

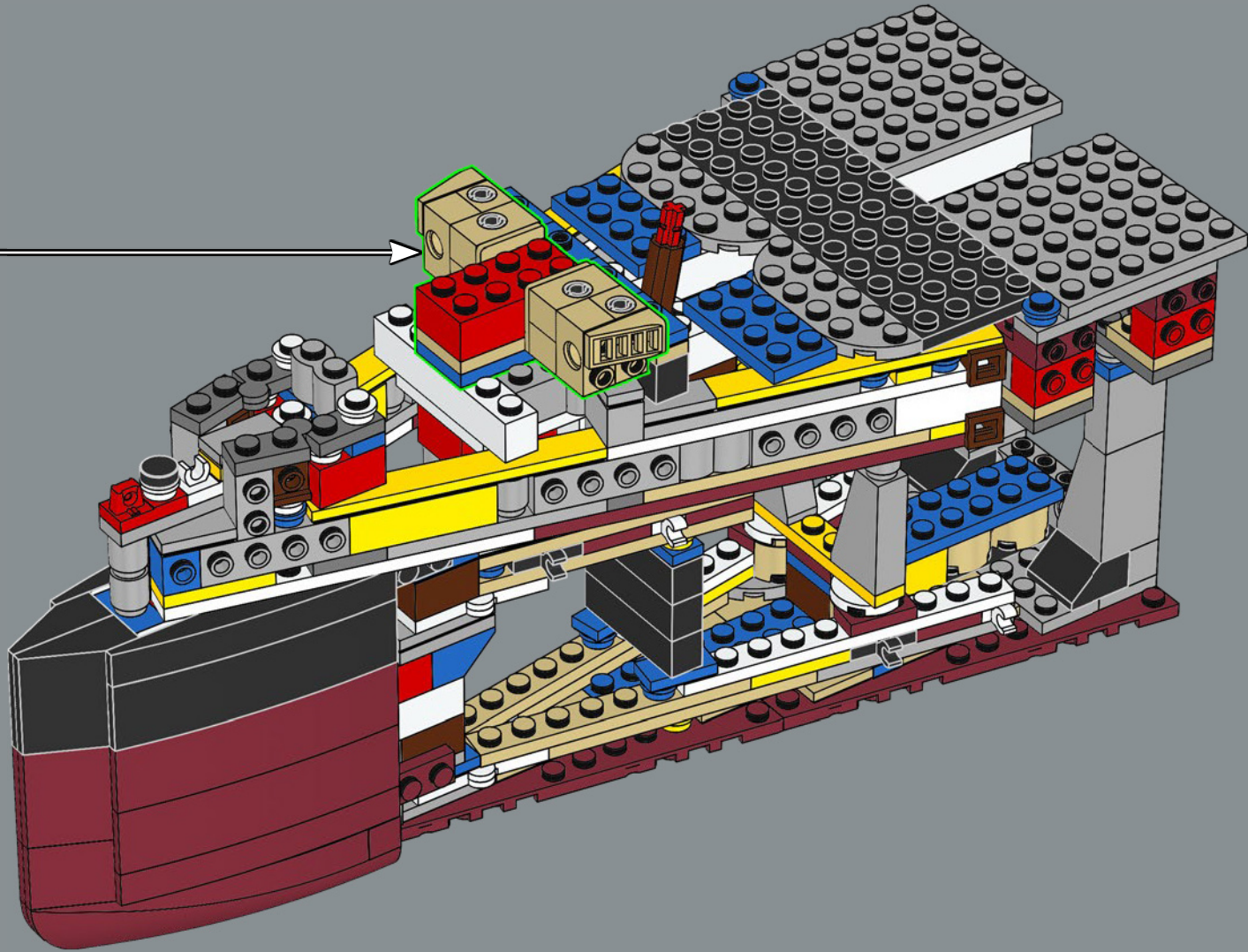

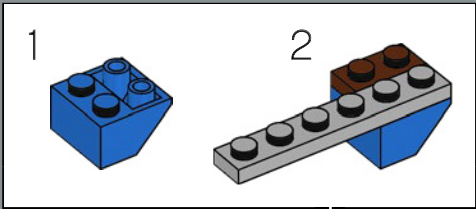
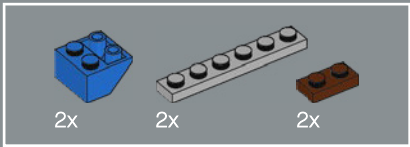

61

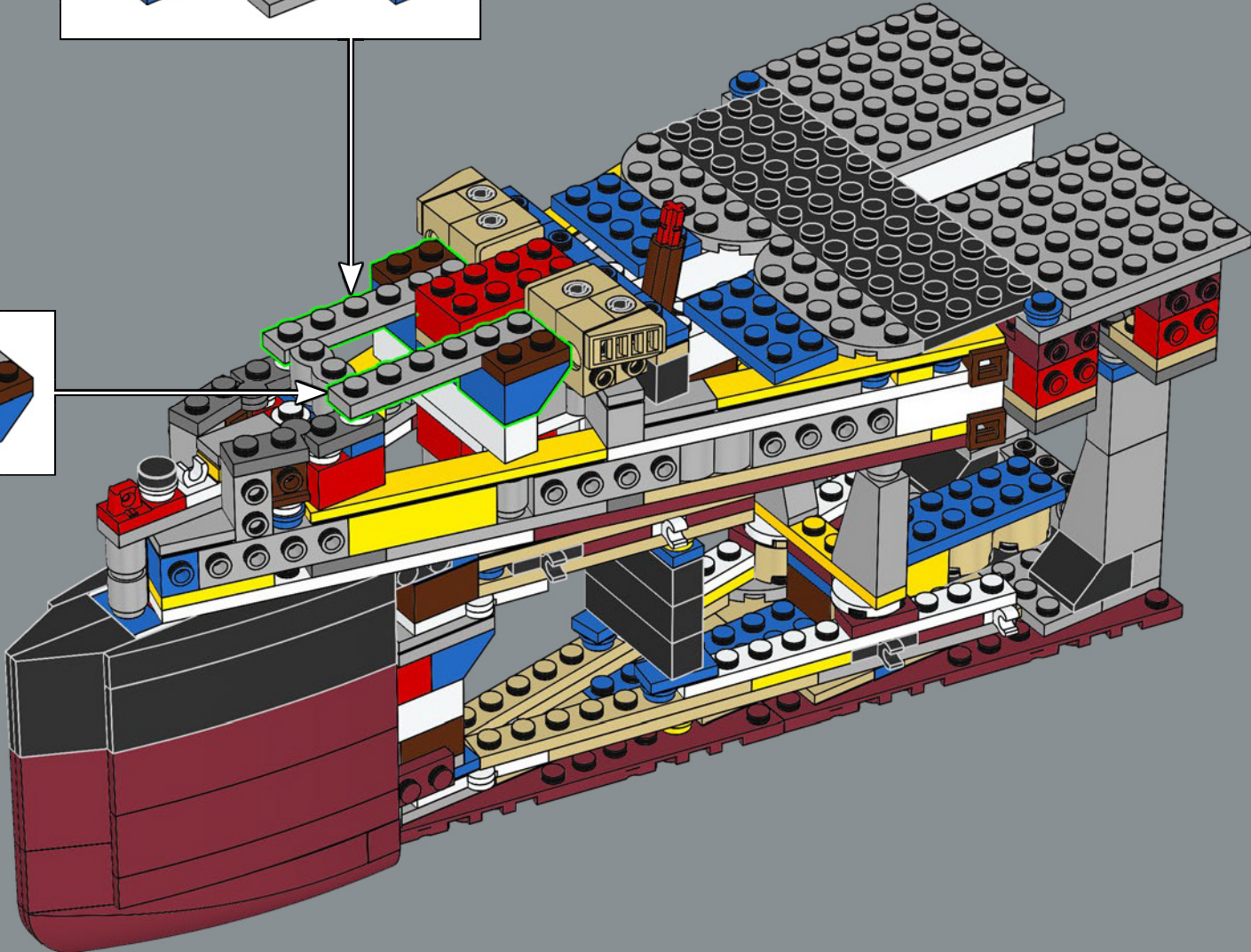
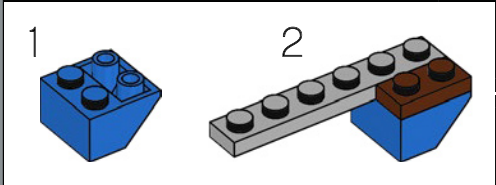



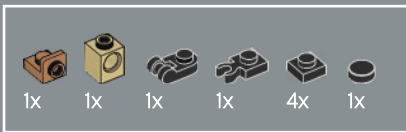

62

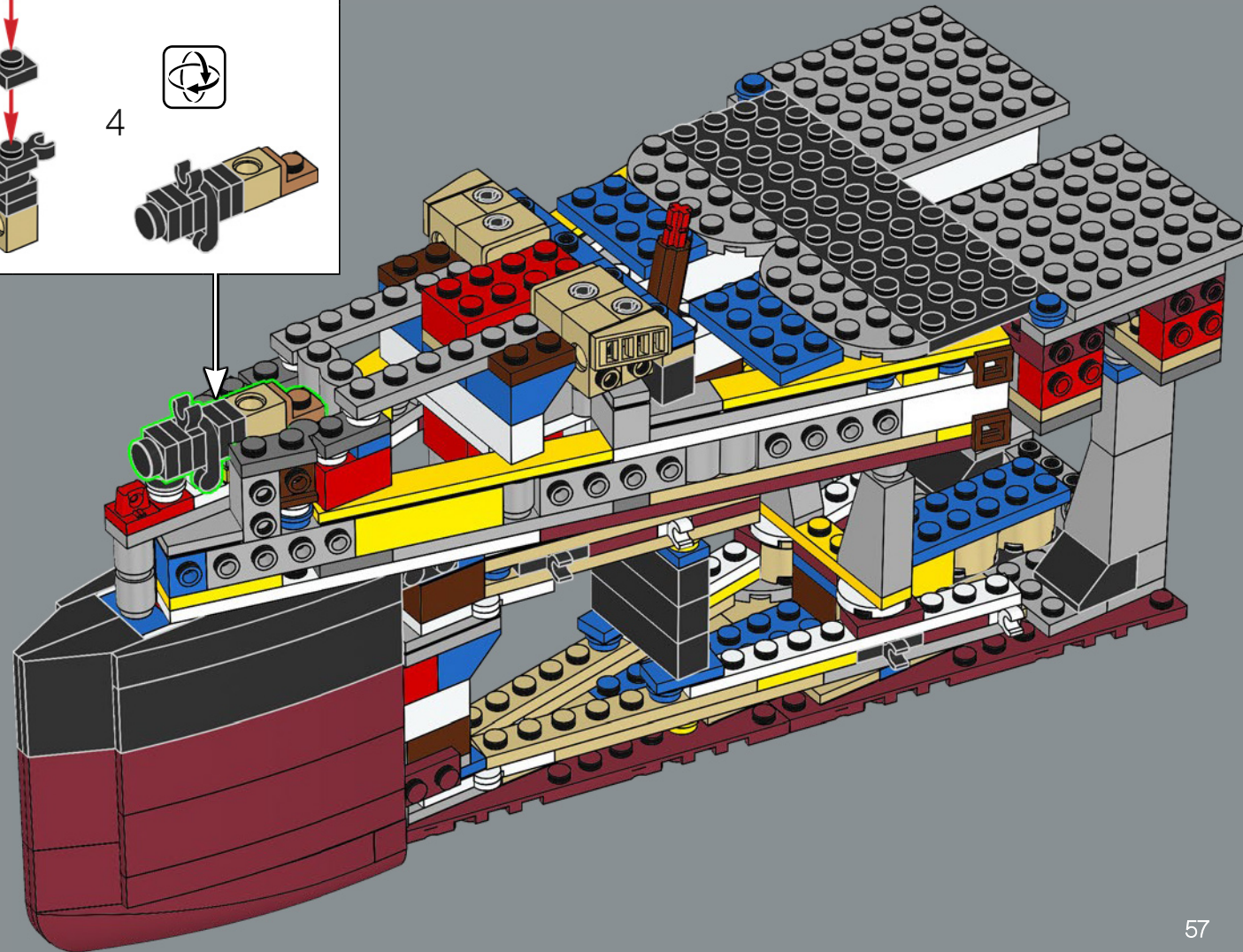
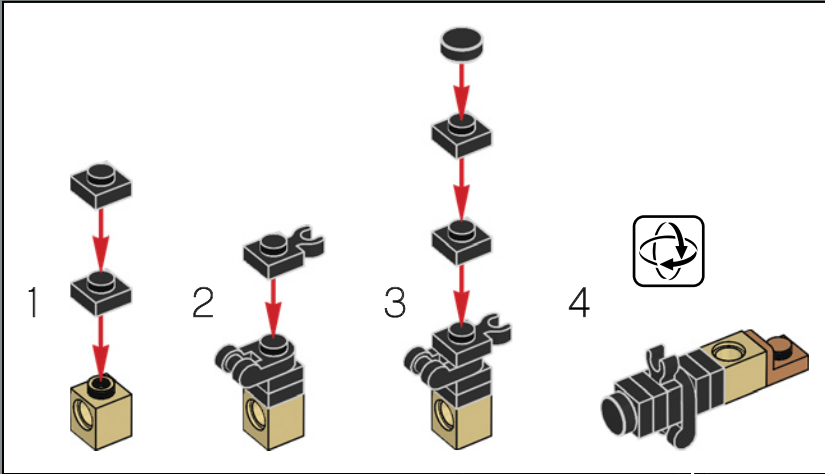

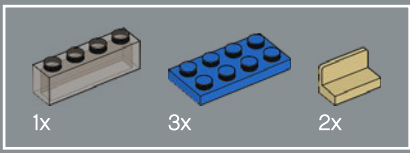

63

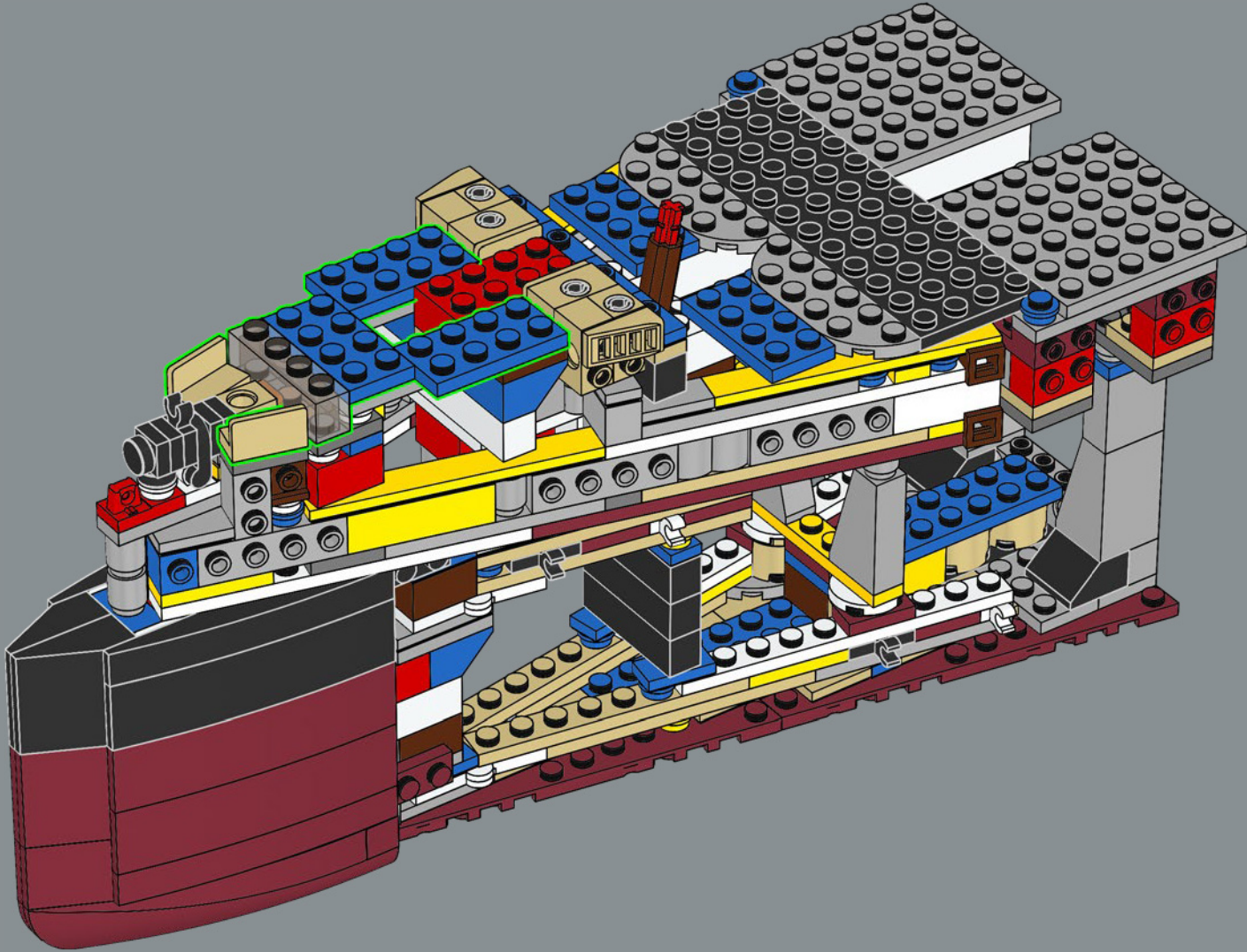

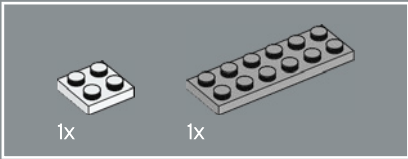
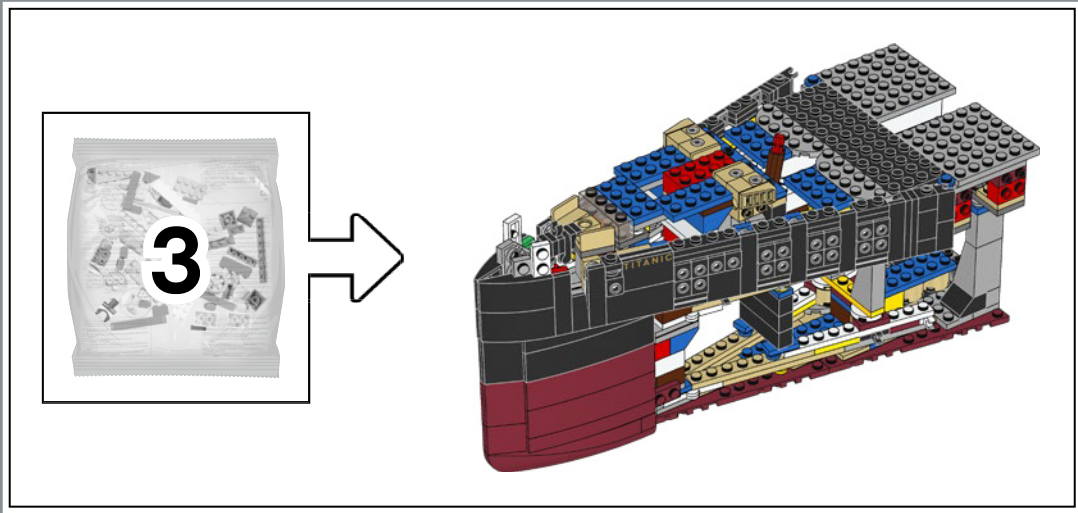

65

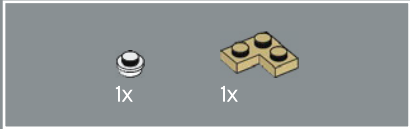
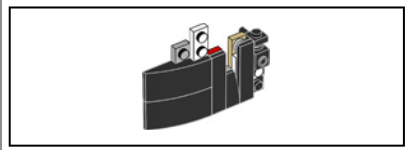

64

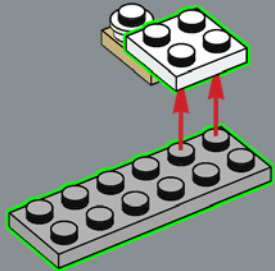
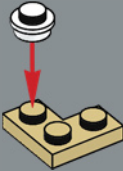

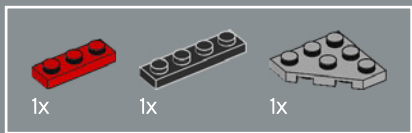

66

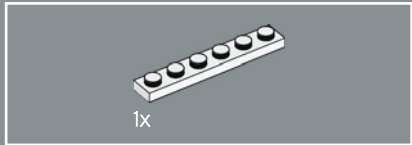
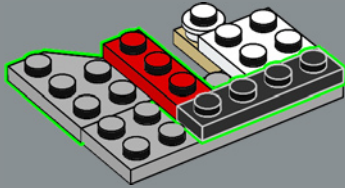

67

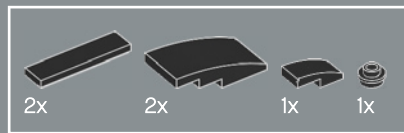
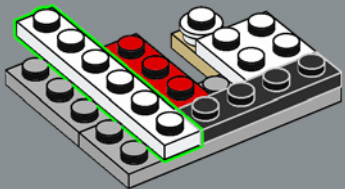

68

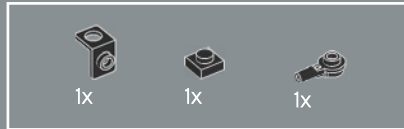
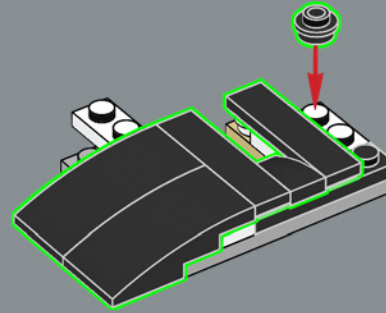

69

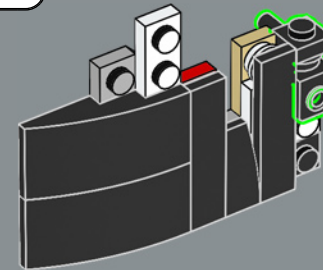
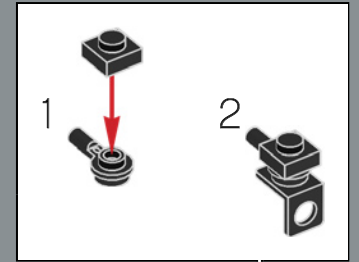

70

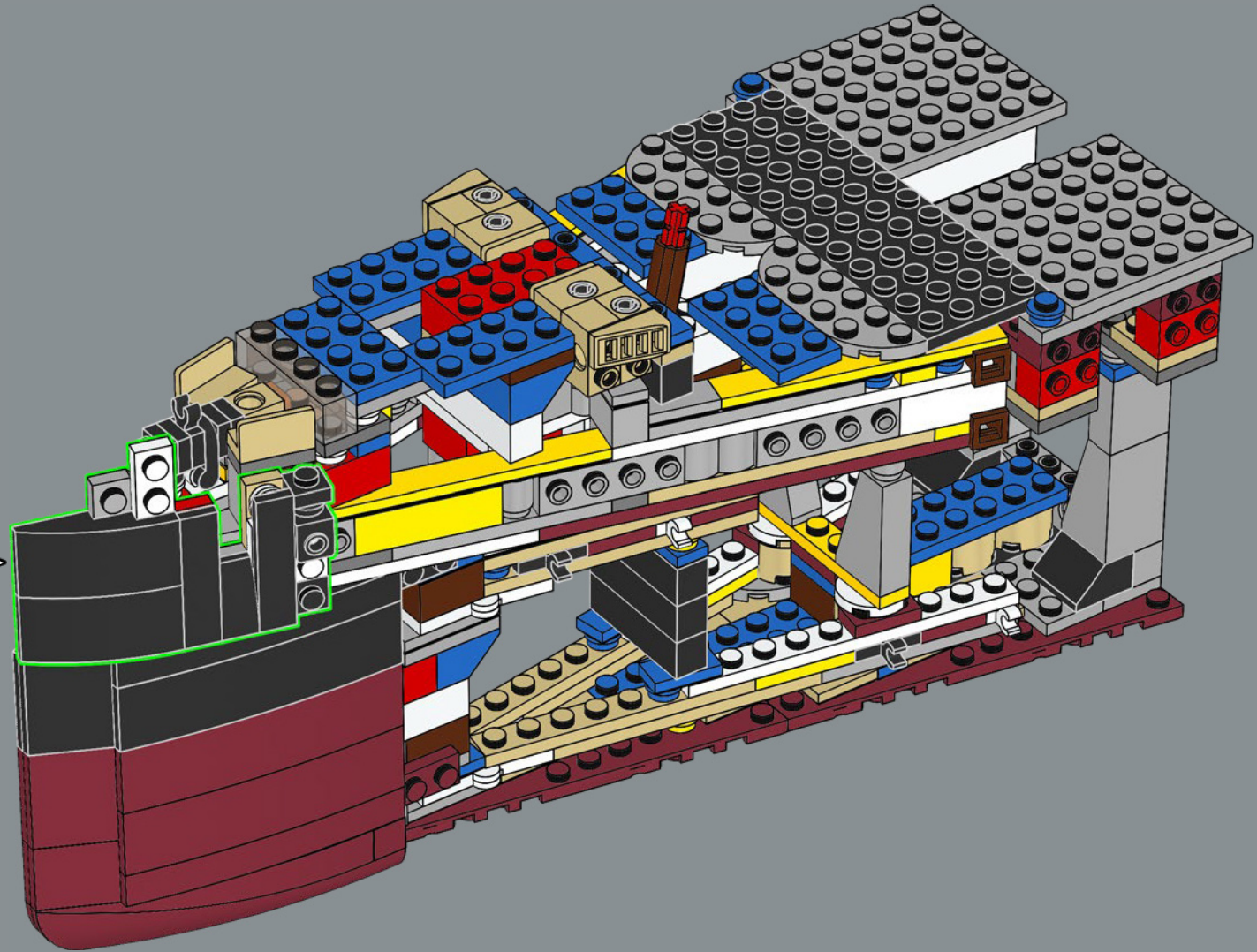

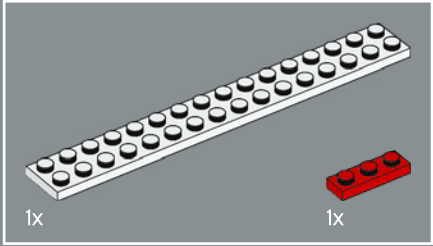
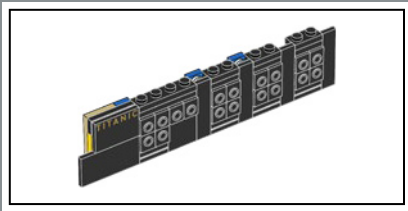

71

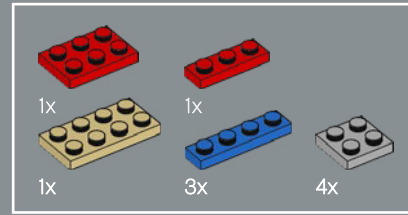
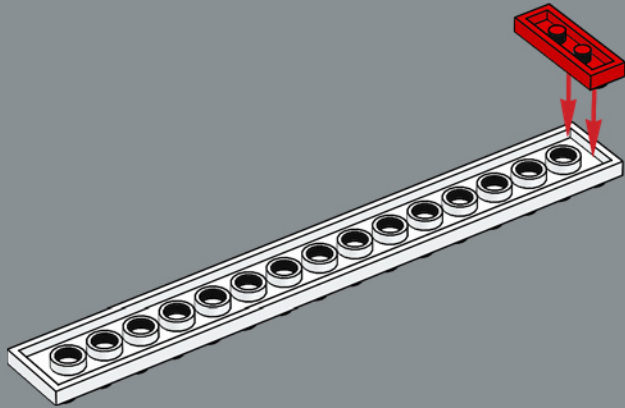

72

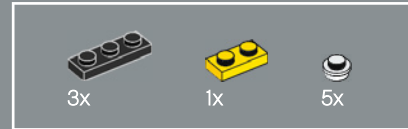
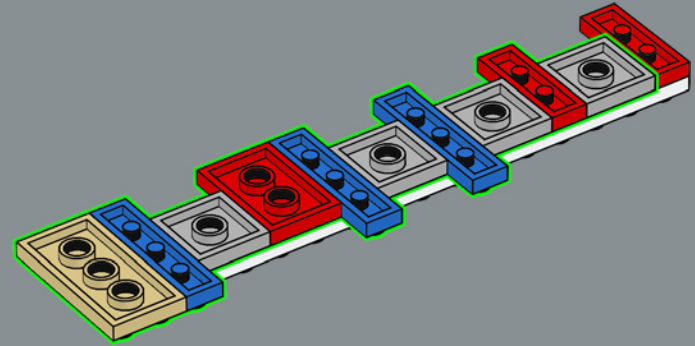

73

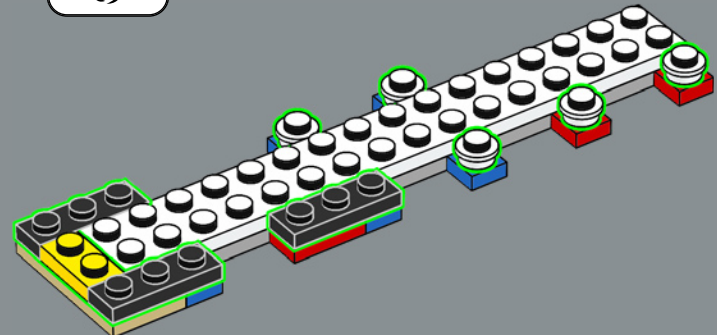

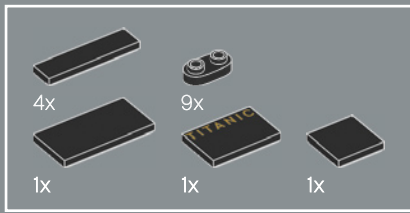

74

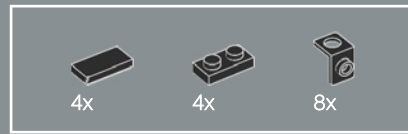
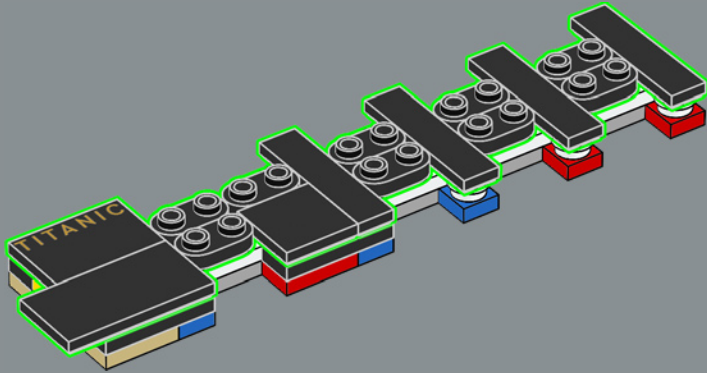

75

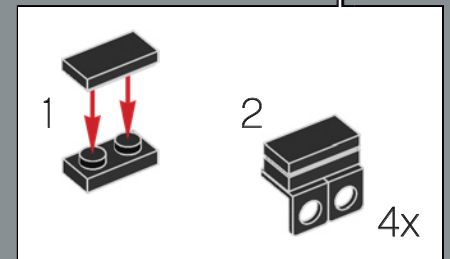
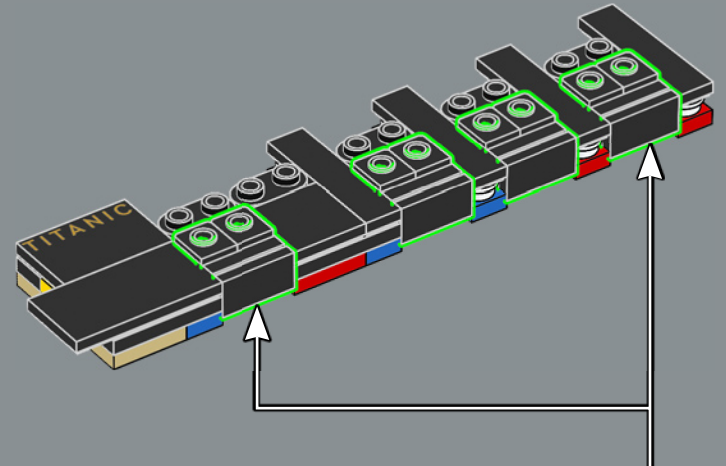

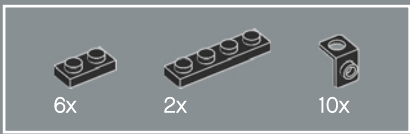

76

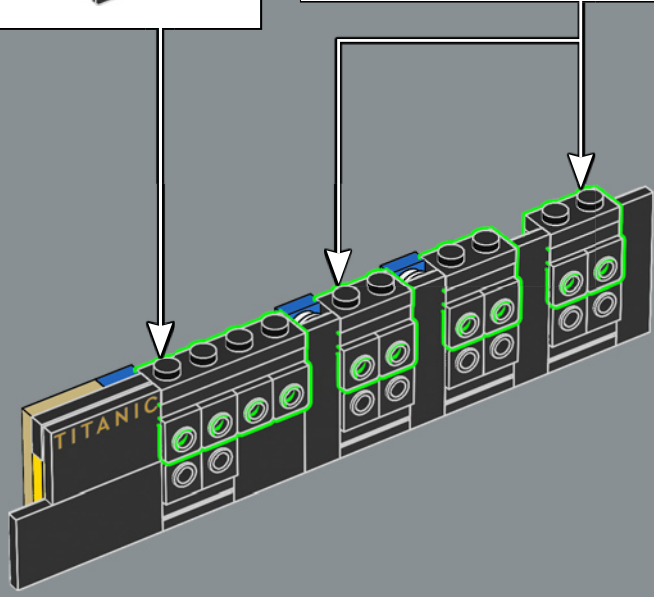
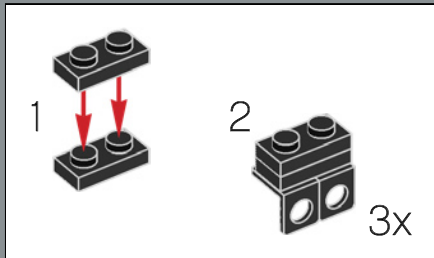
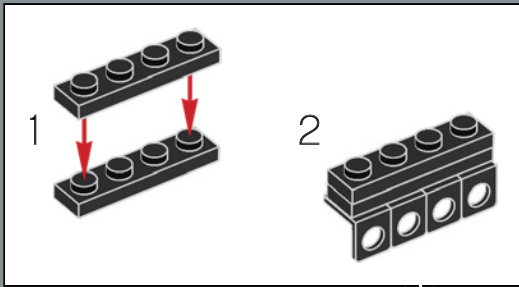



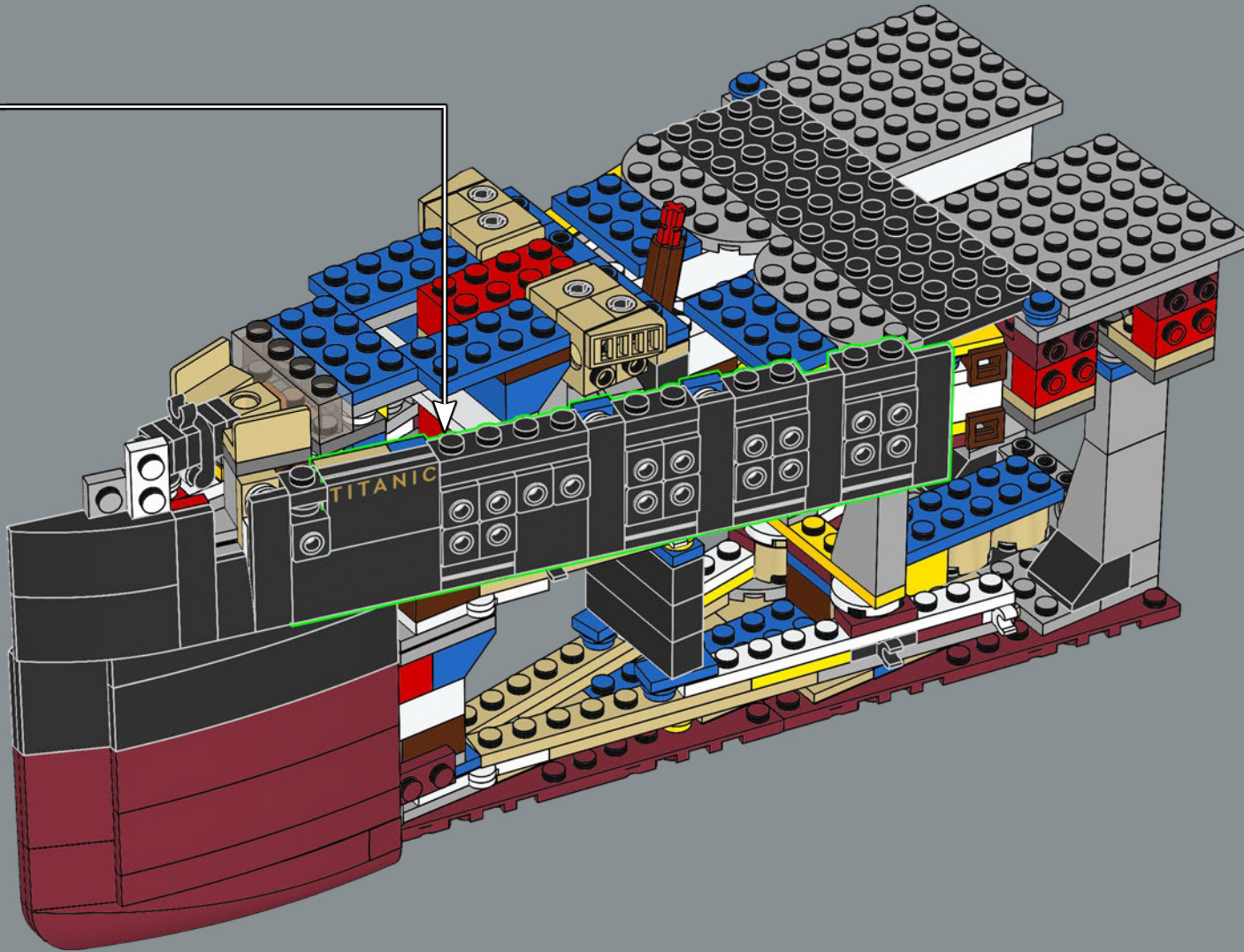

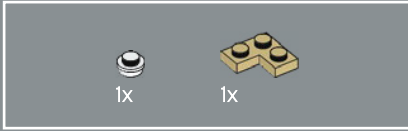
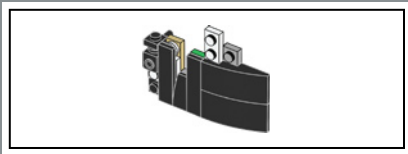

78

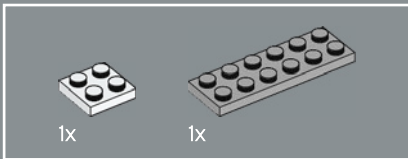
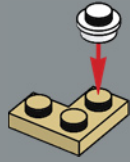

79

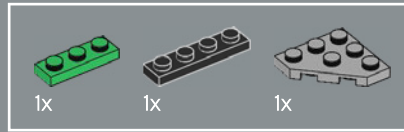
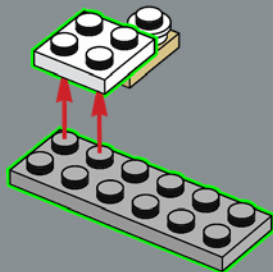

80

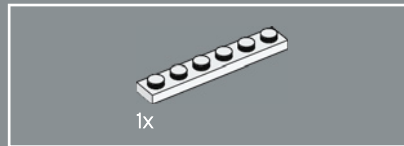
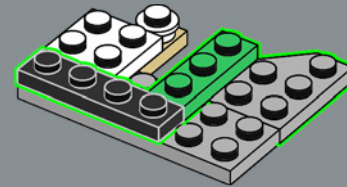

81

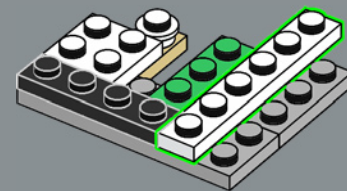



82

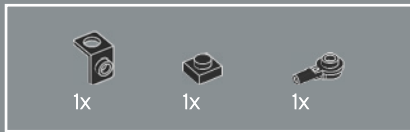
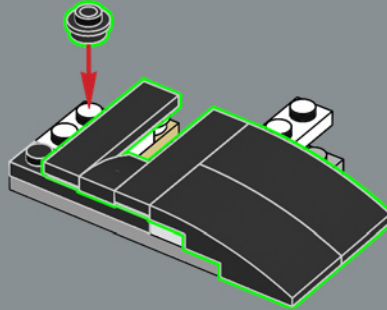

83

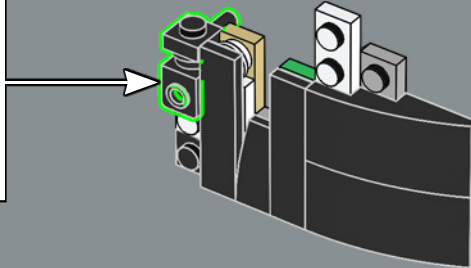
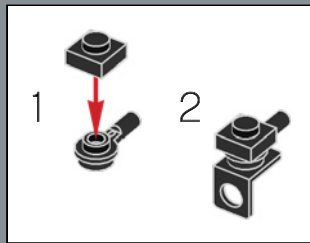

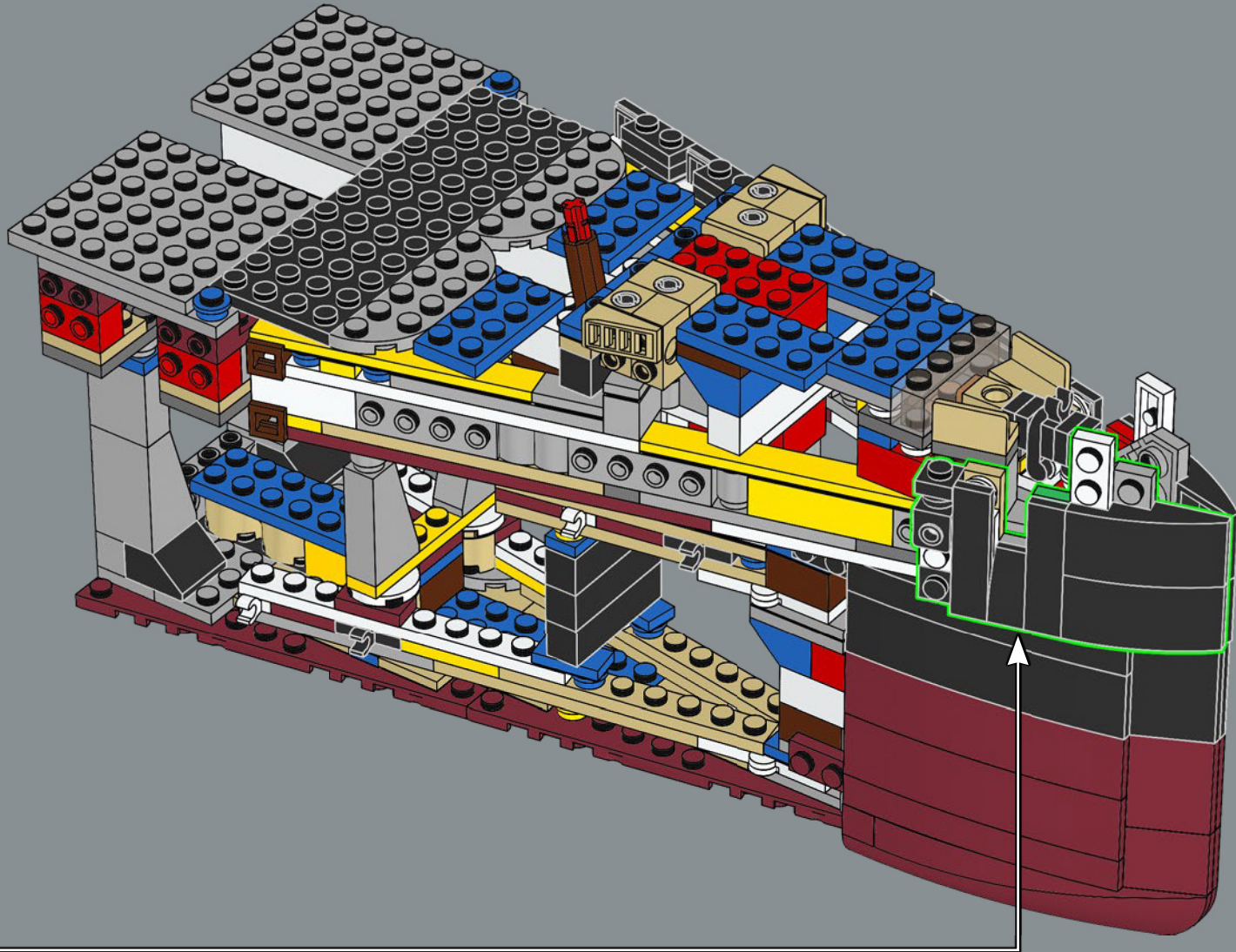

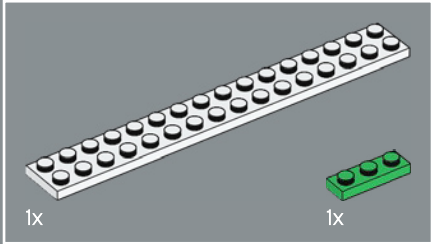
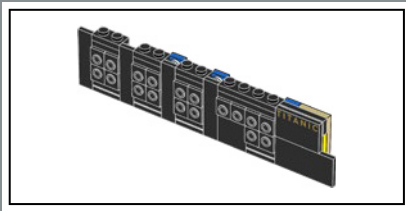

85

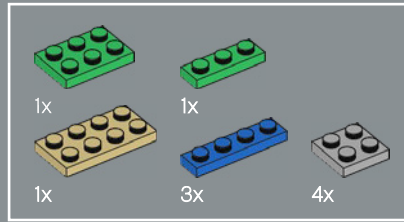
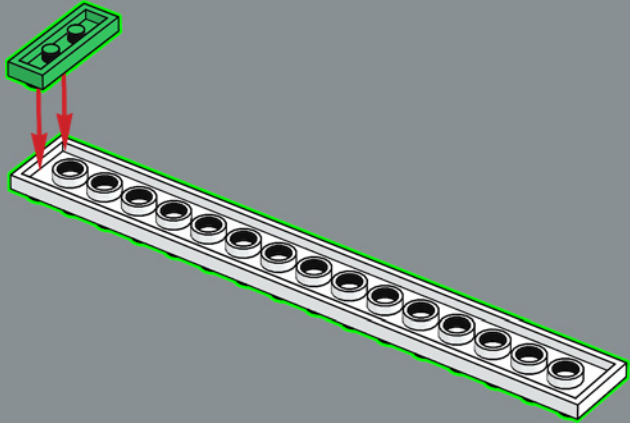

86

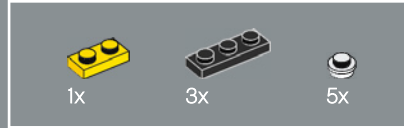
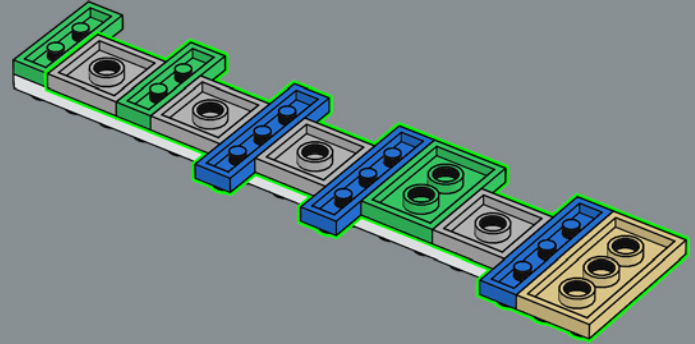

87

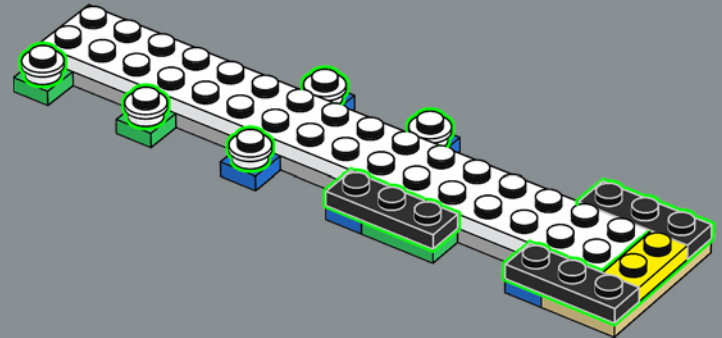

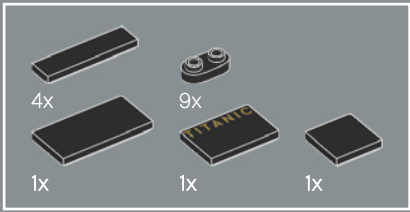

88

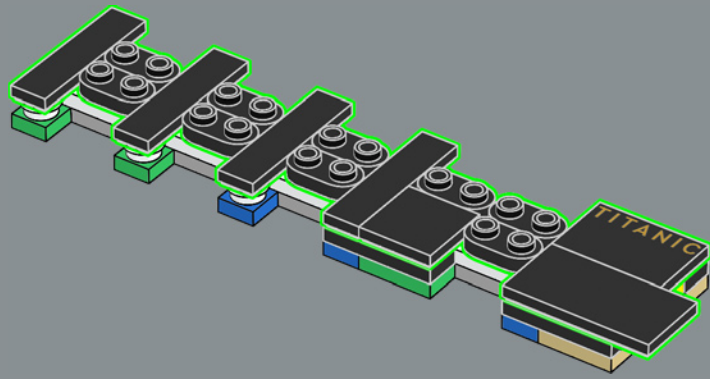

89

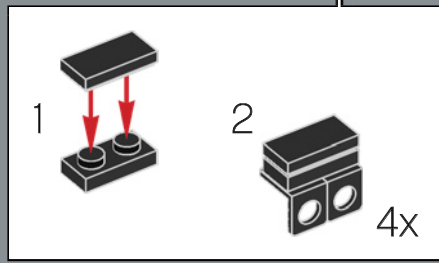
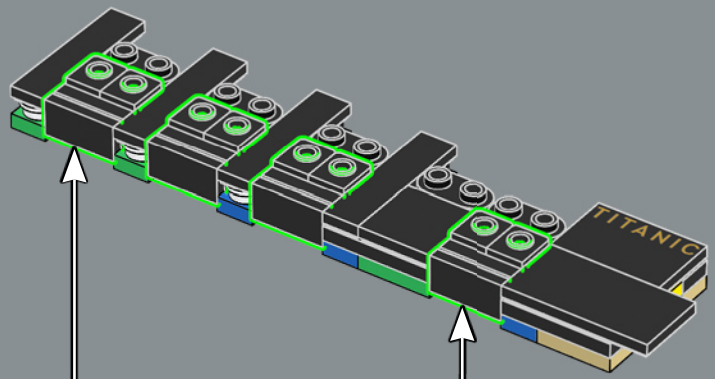

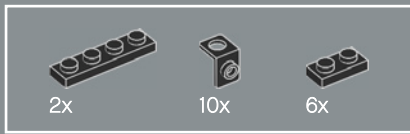

90

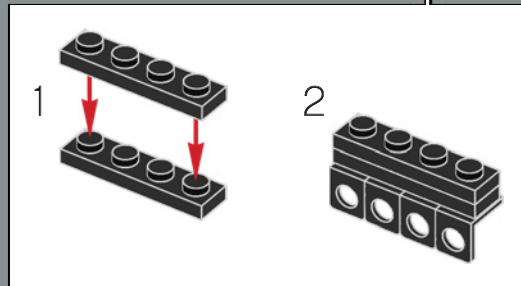
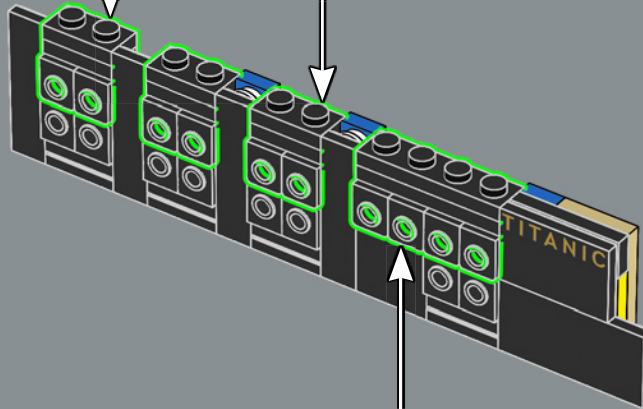
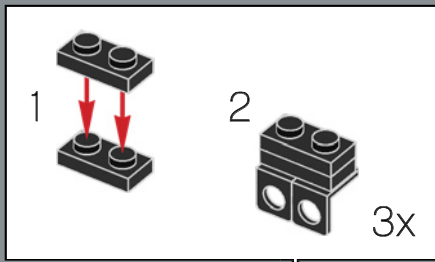

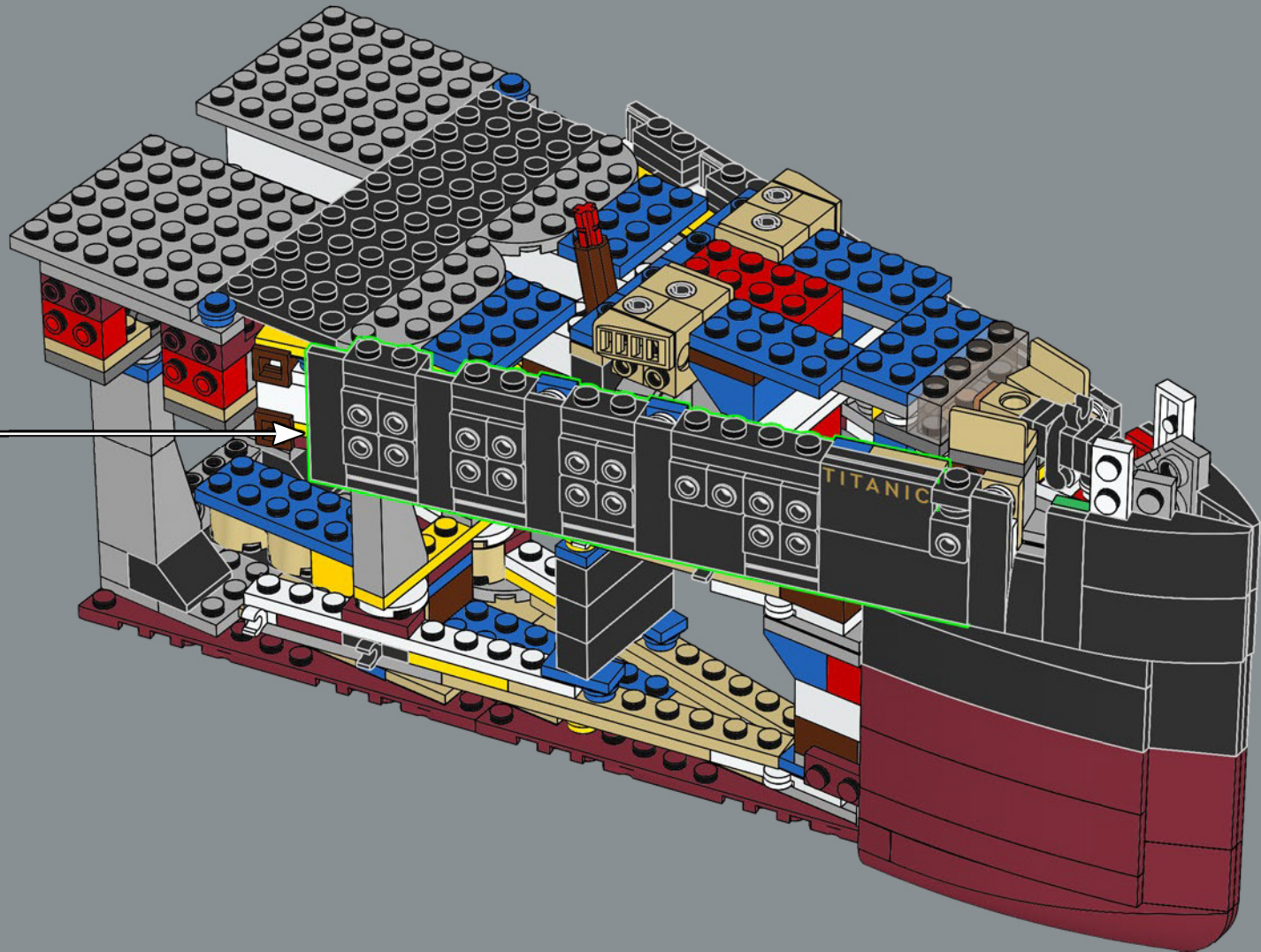



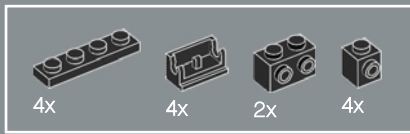

92

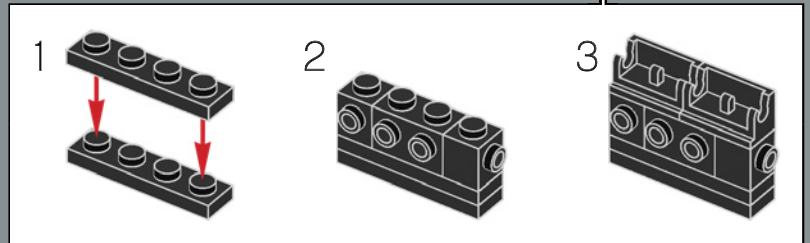
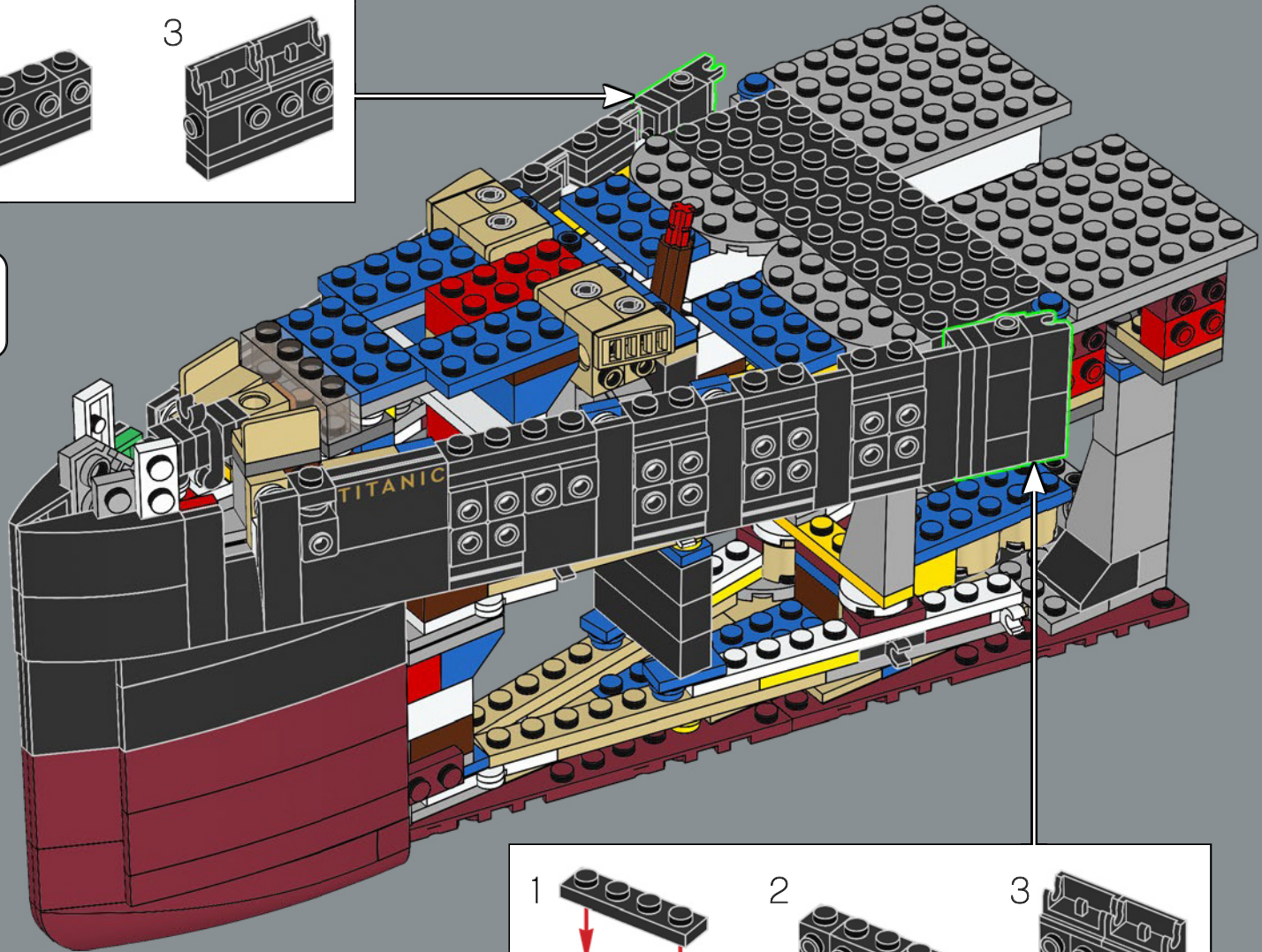
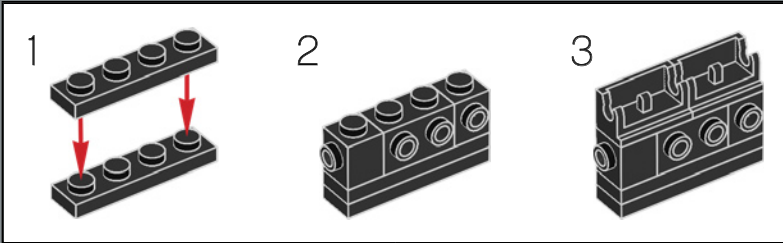

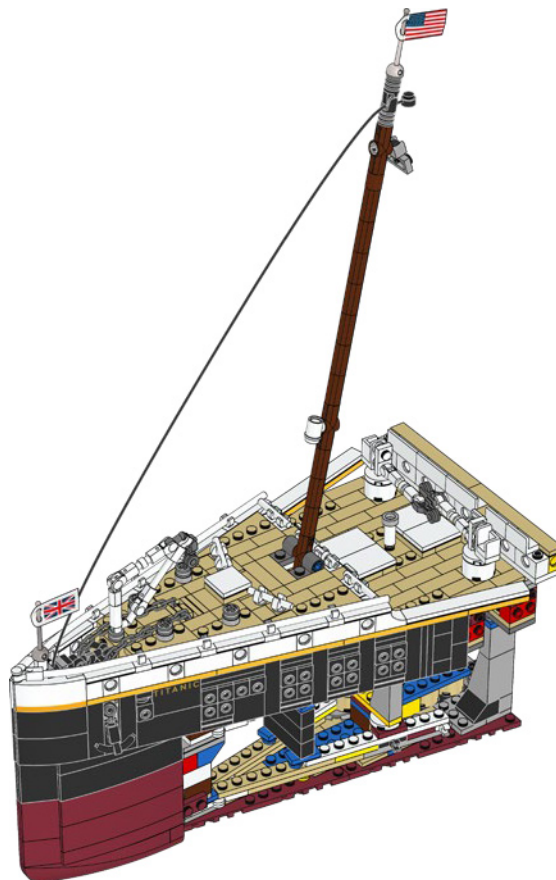

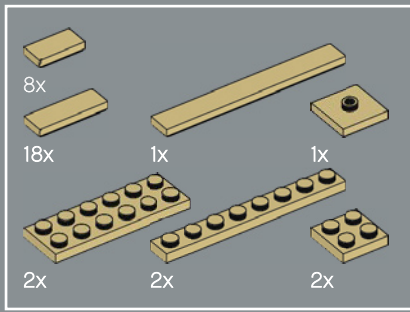

93

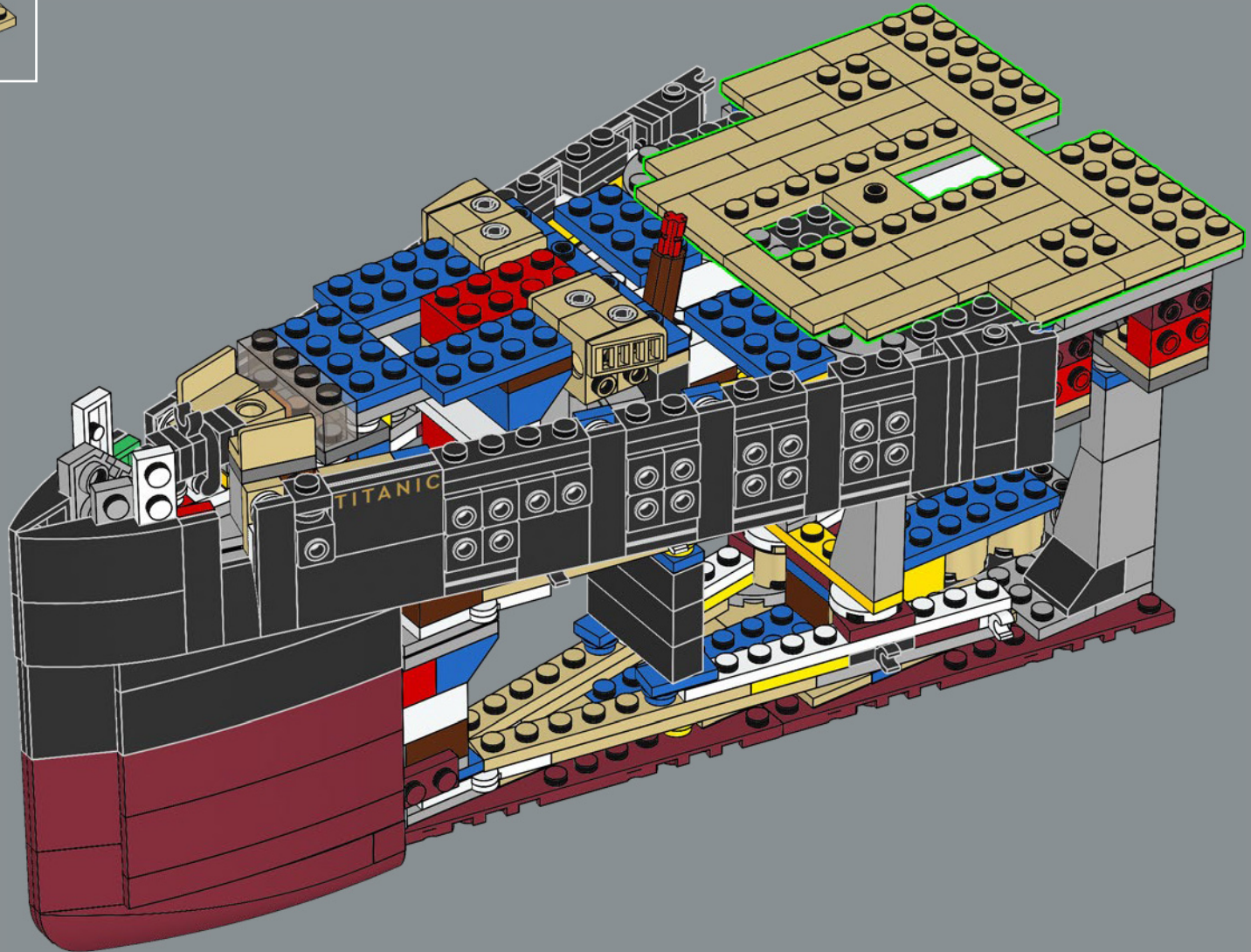

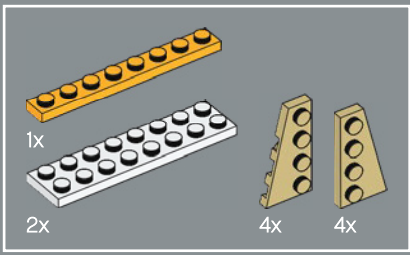

94

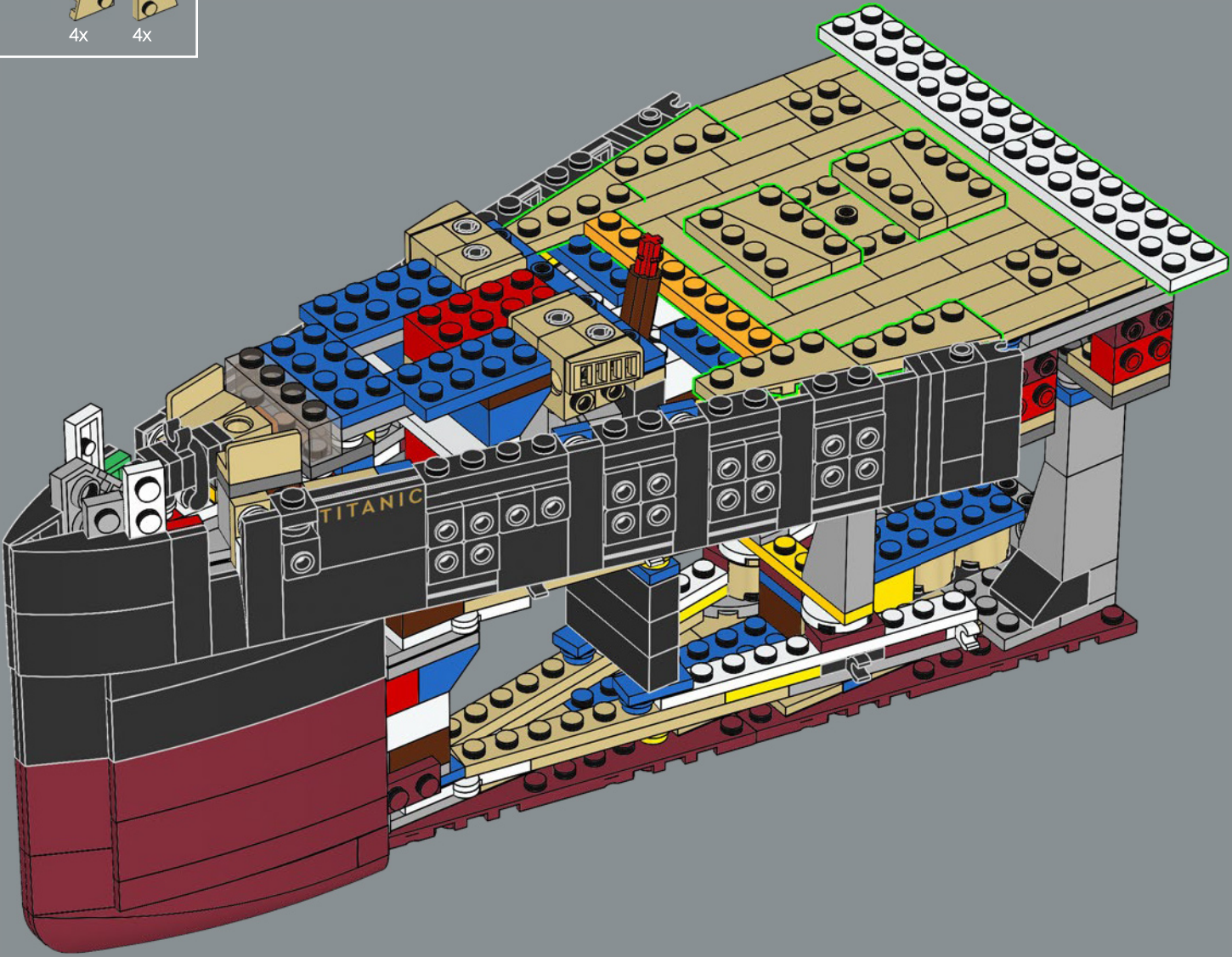

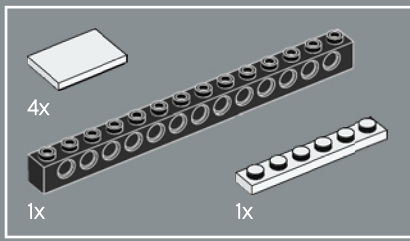

95

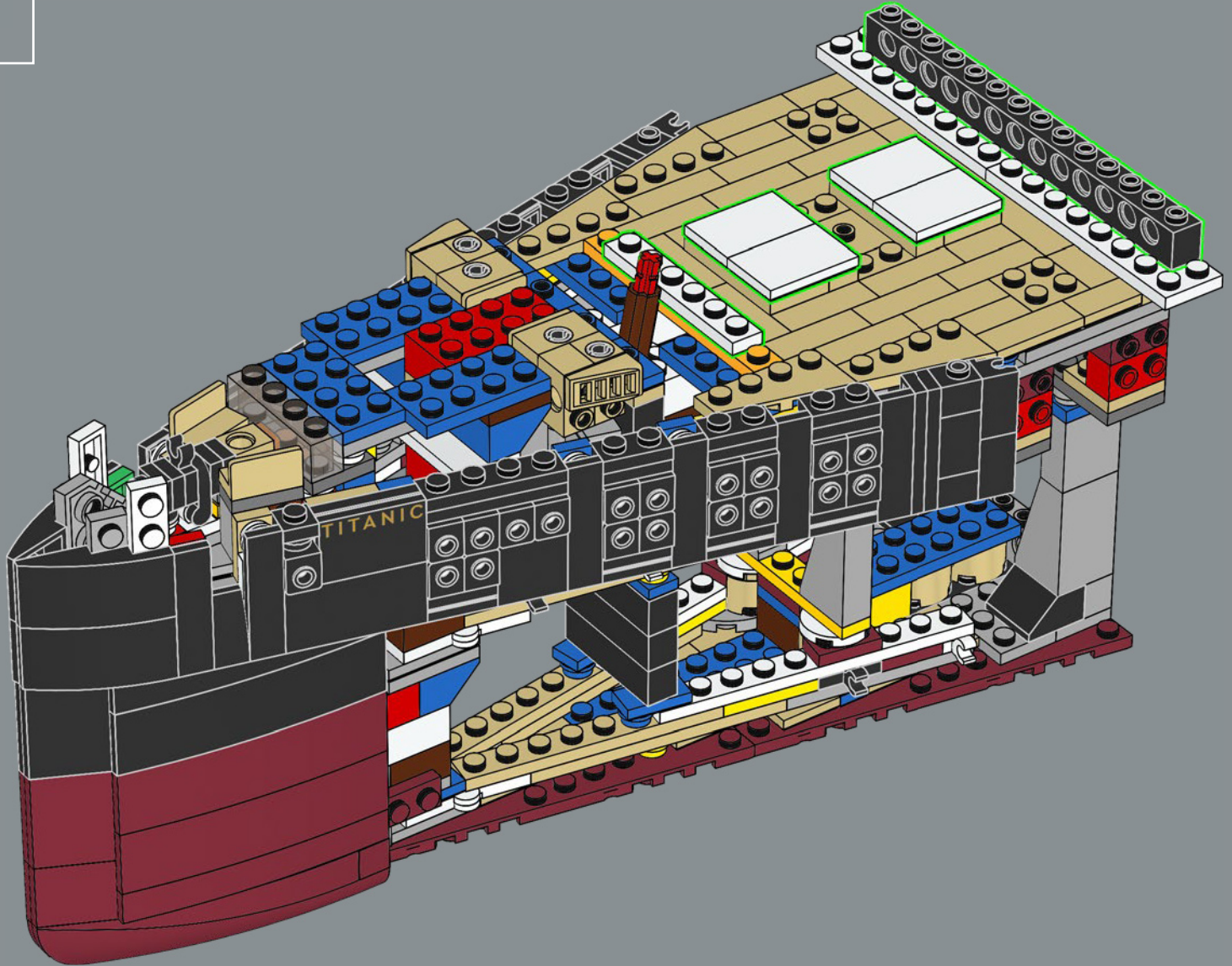

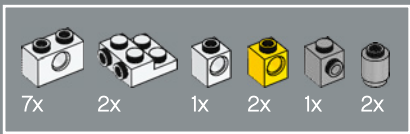

96

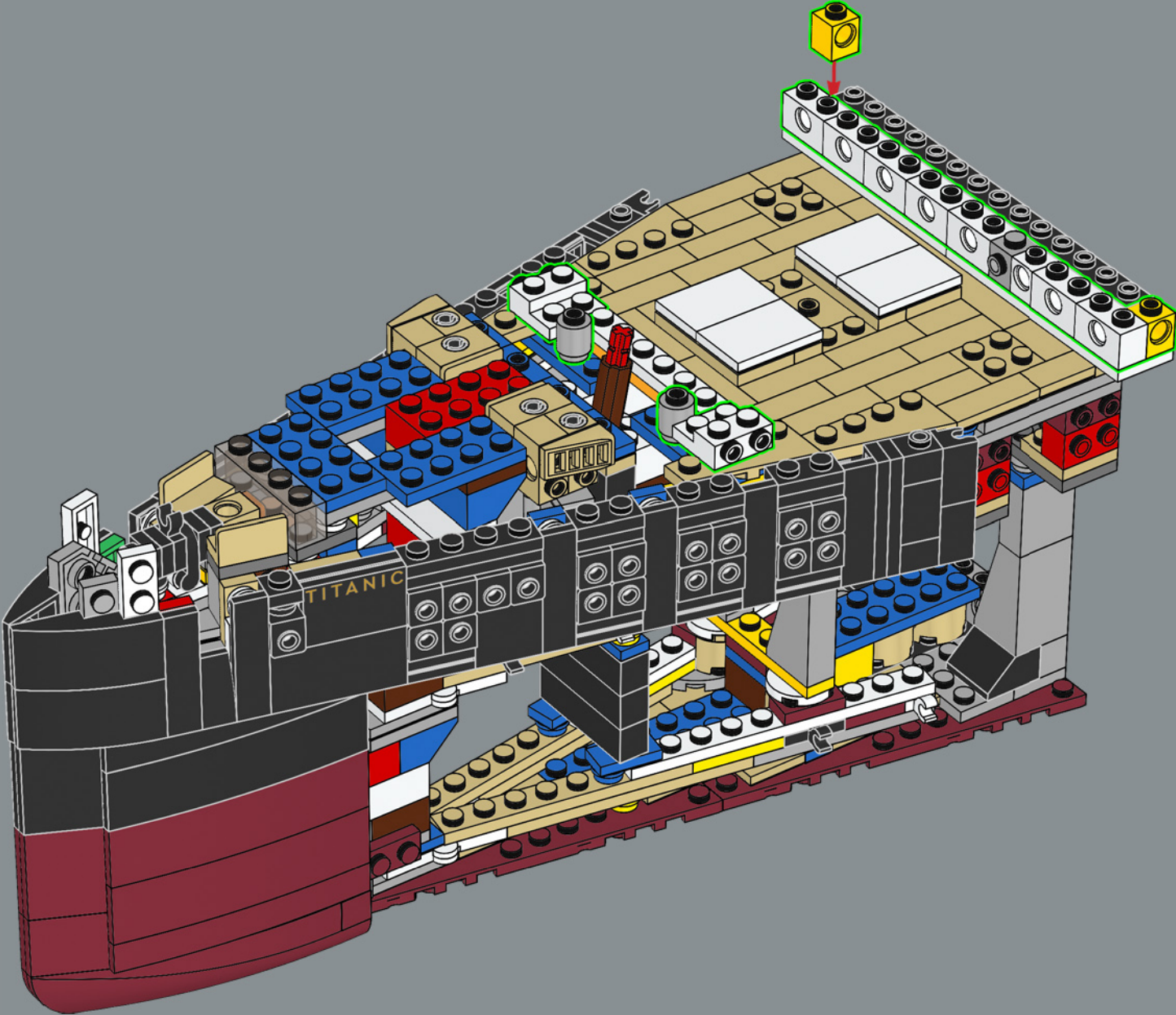

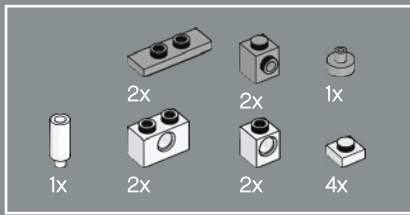

97

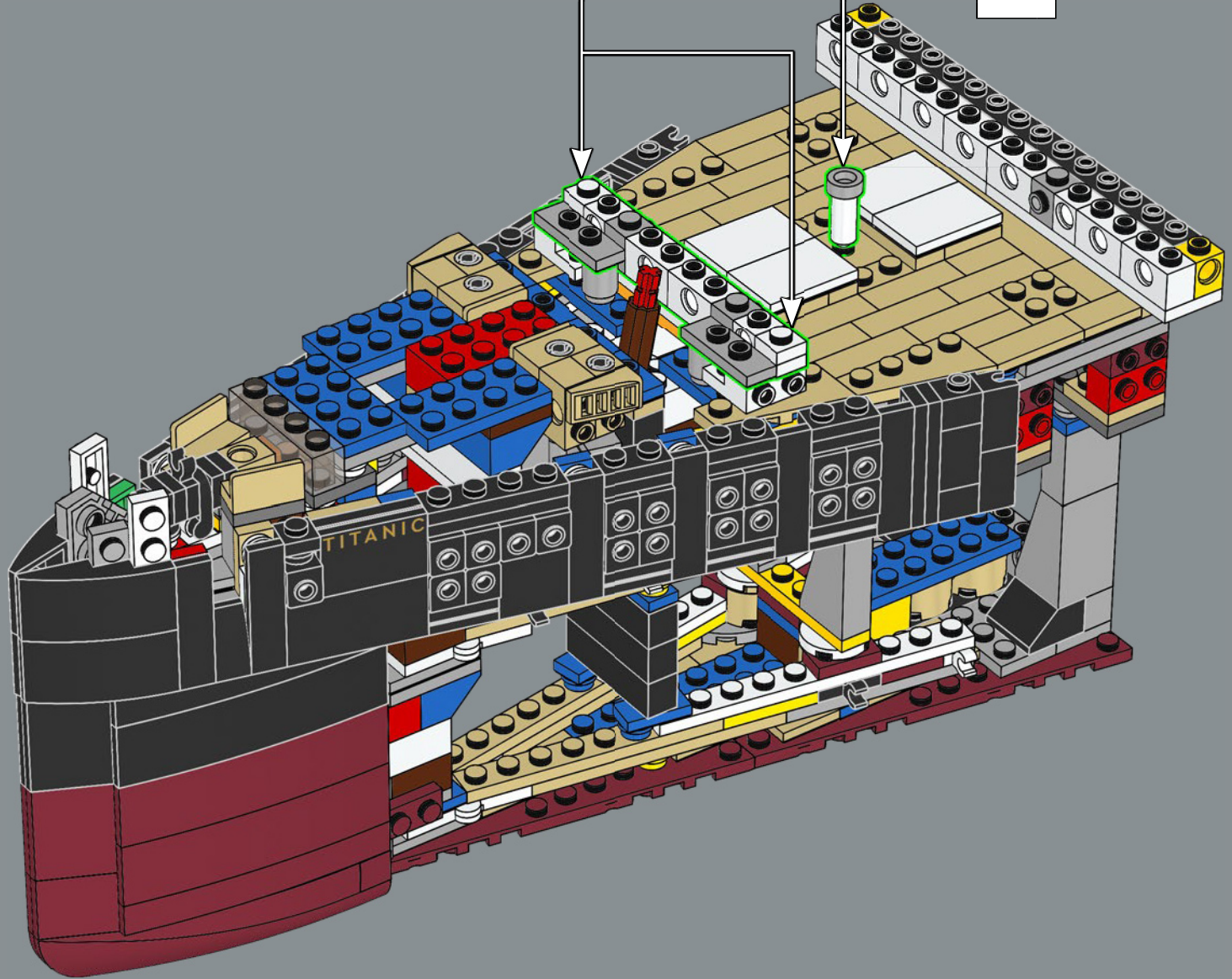
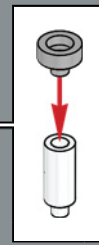
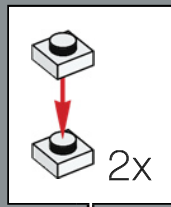

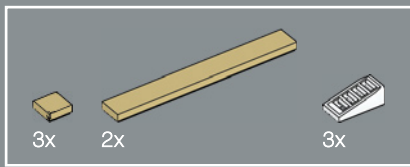

98

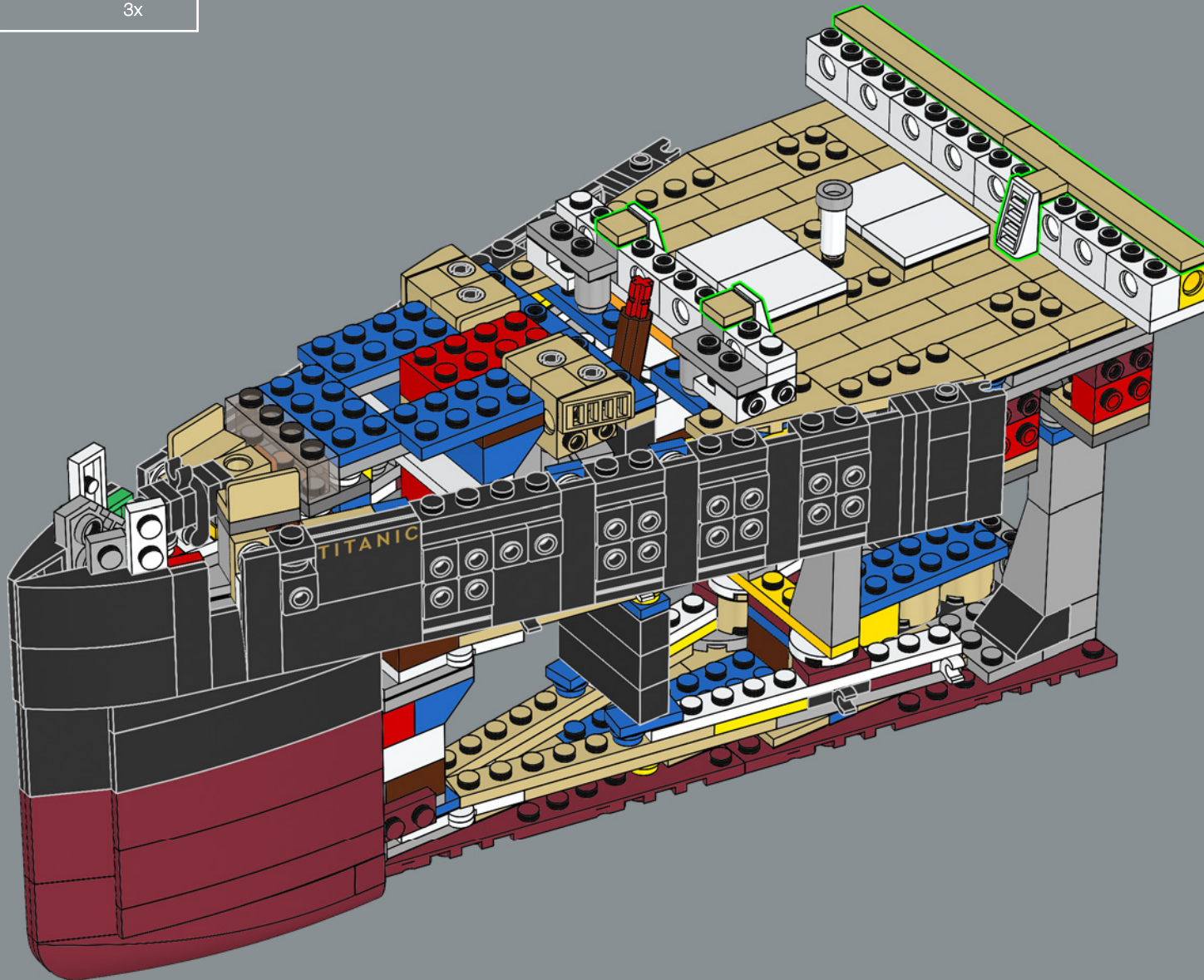



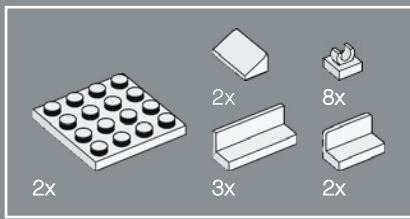

99

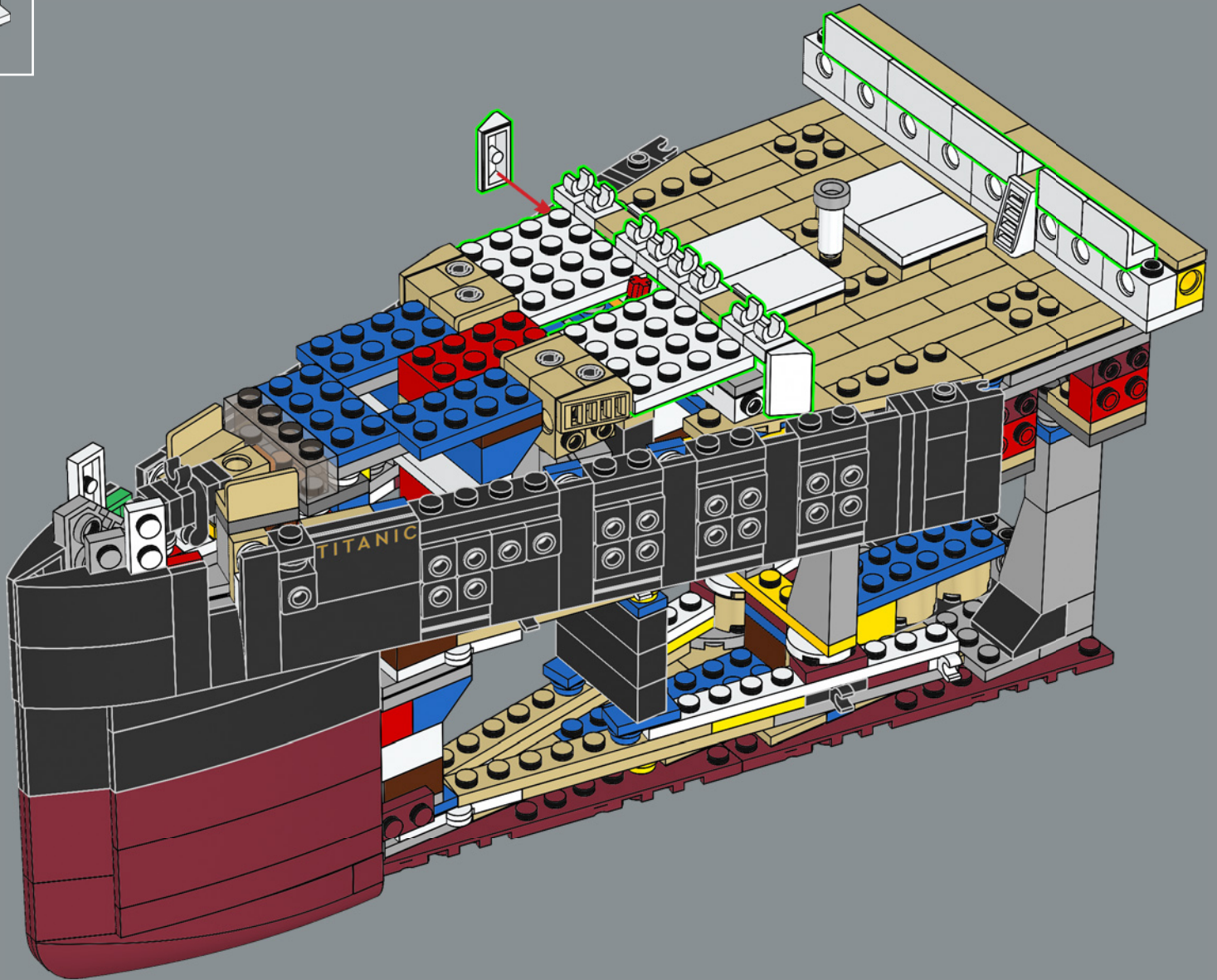

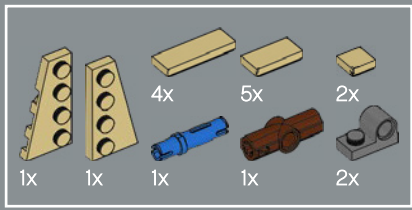

100

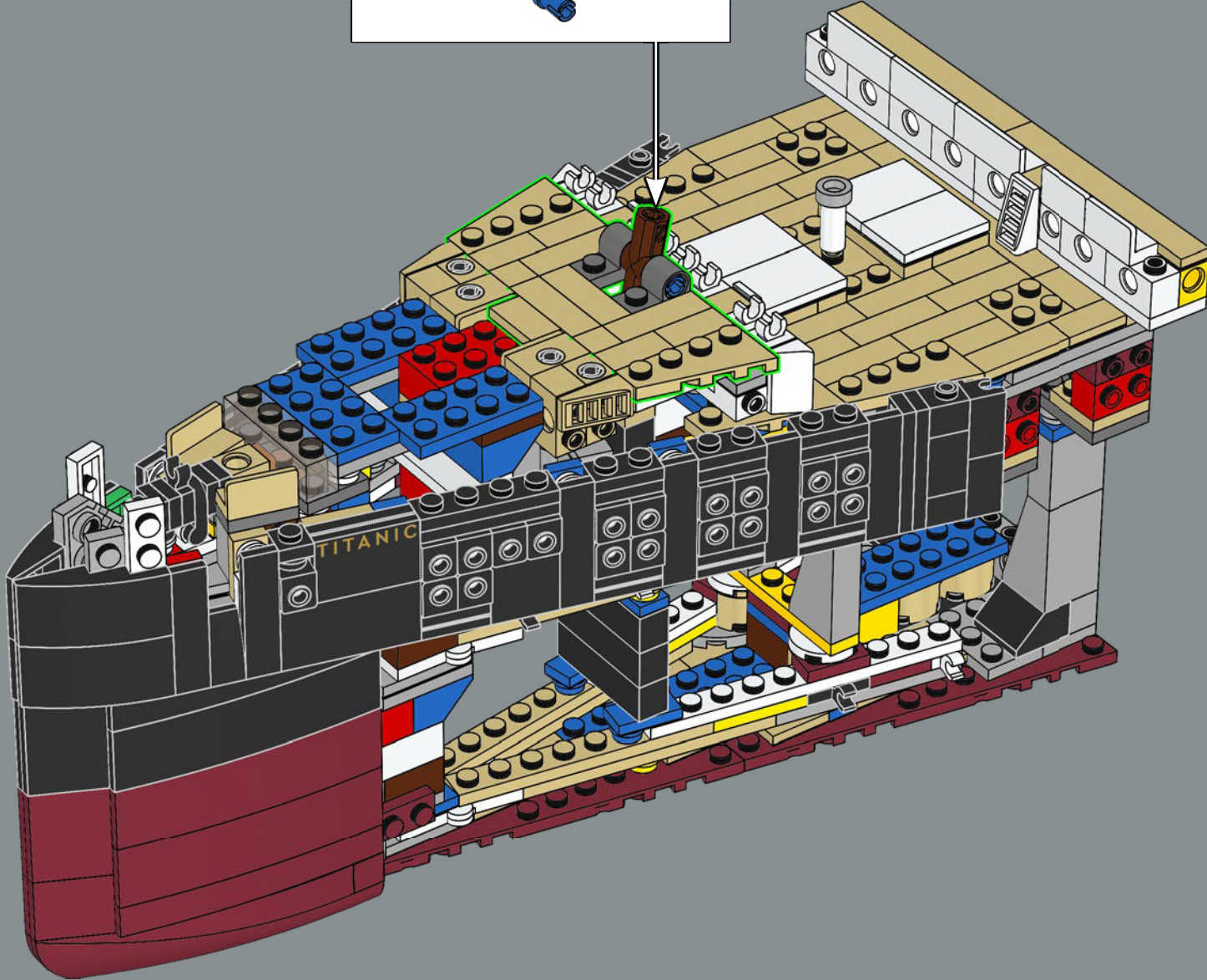
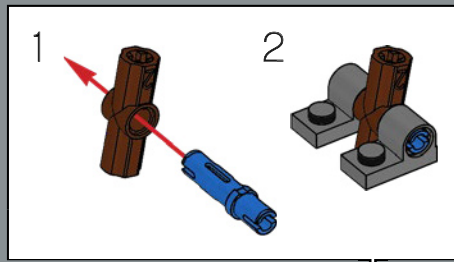

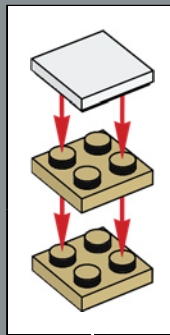
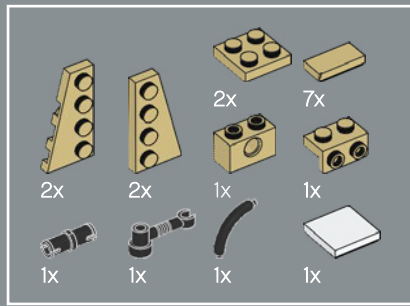

101

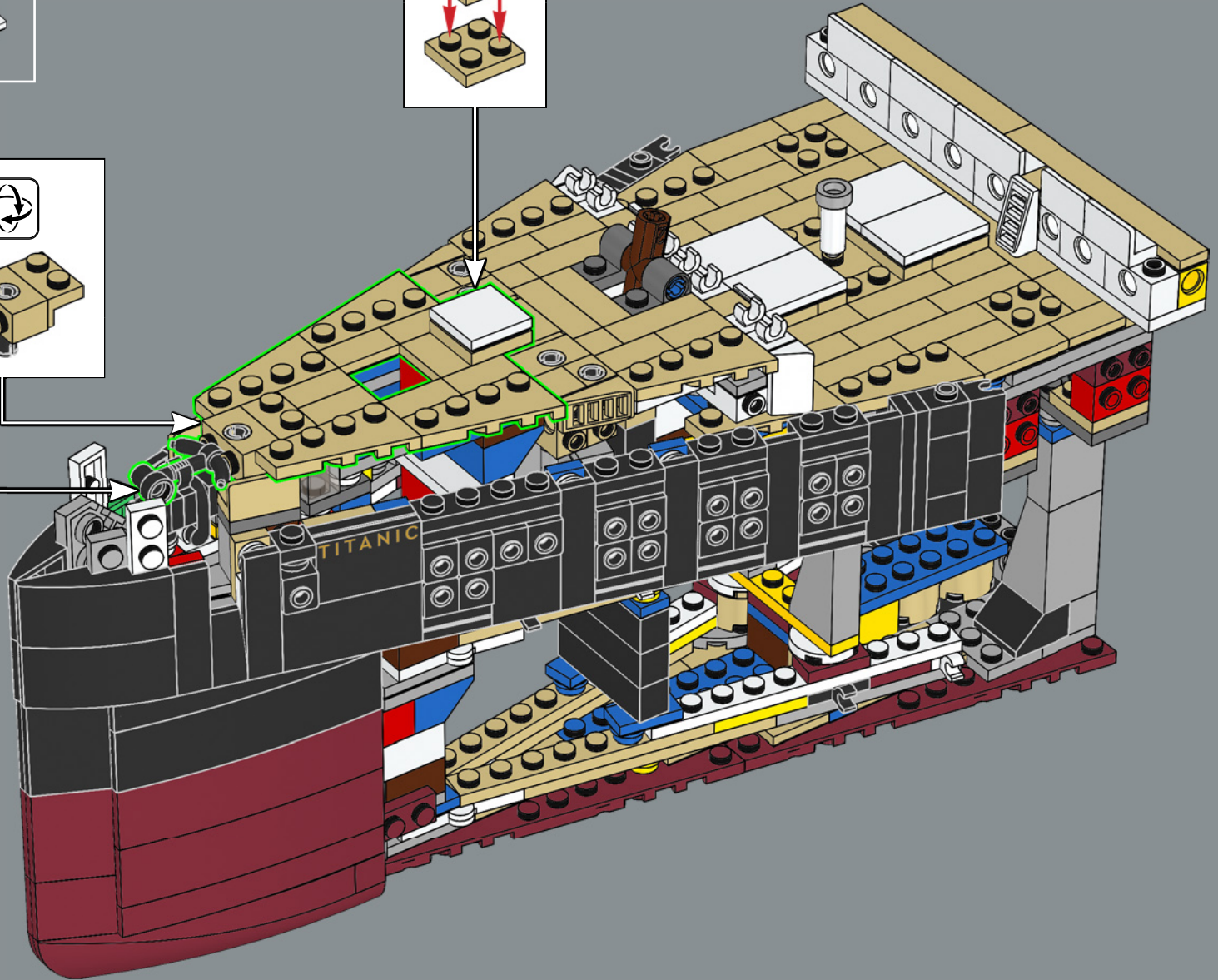
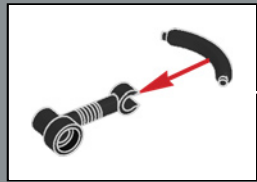
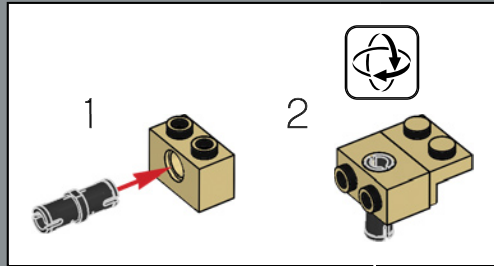

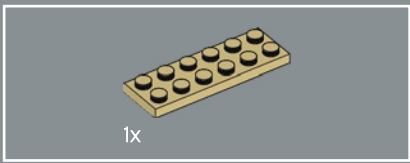

102

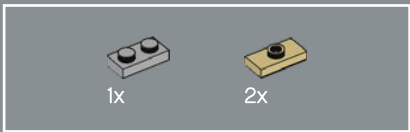
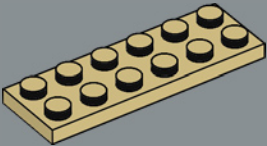

103

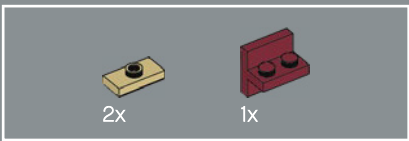
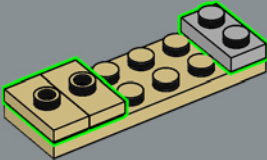

104

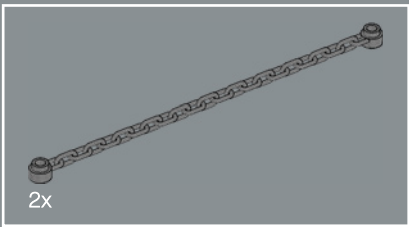
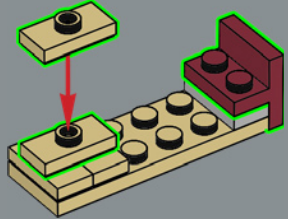

105

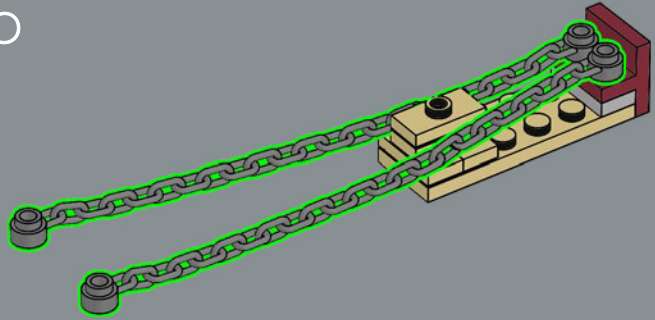

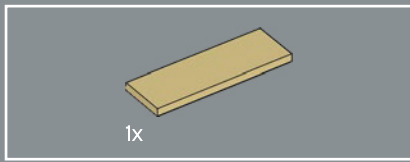

106

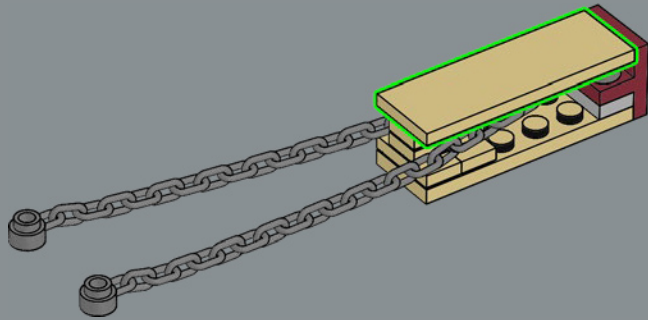

107

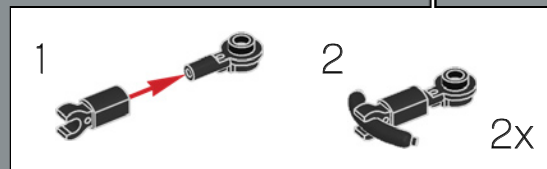
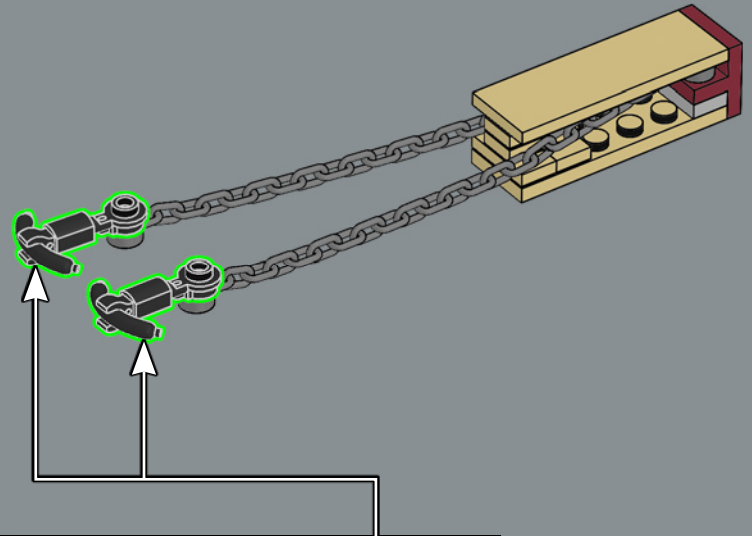

Die Titanic war mit 3 Ankern ausgestattet:  
jeweils einer befand sich an Steuerbord und  
Backbord – und der schwerste saß in der Mitte.

108

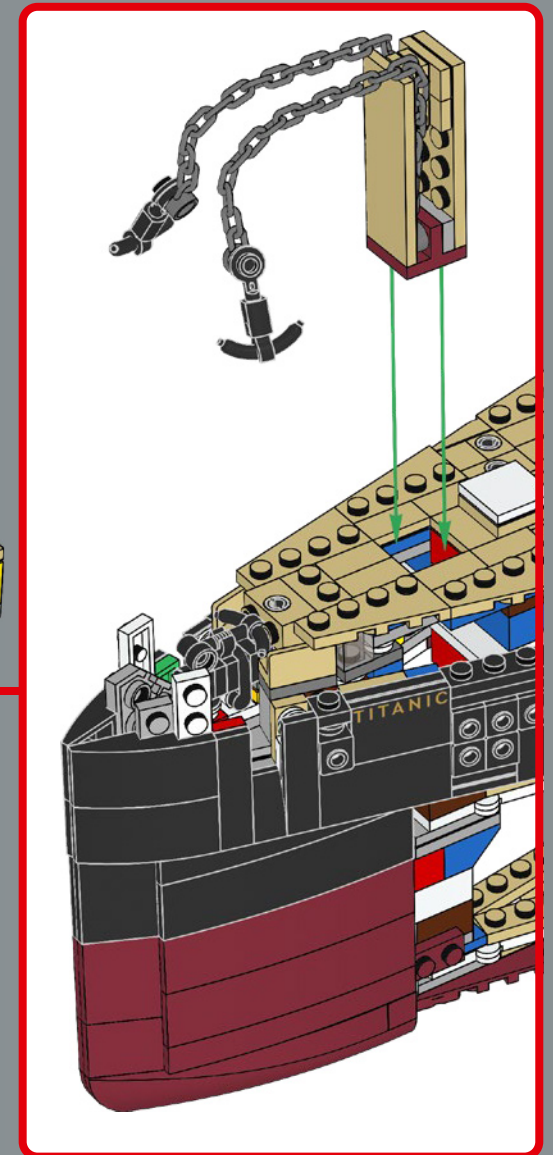
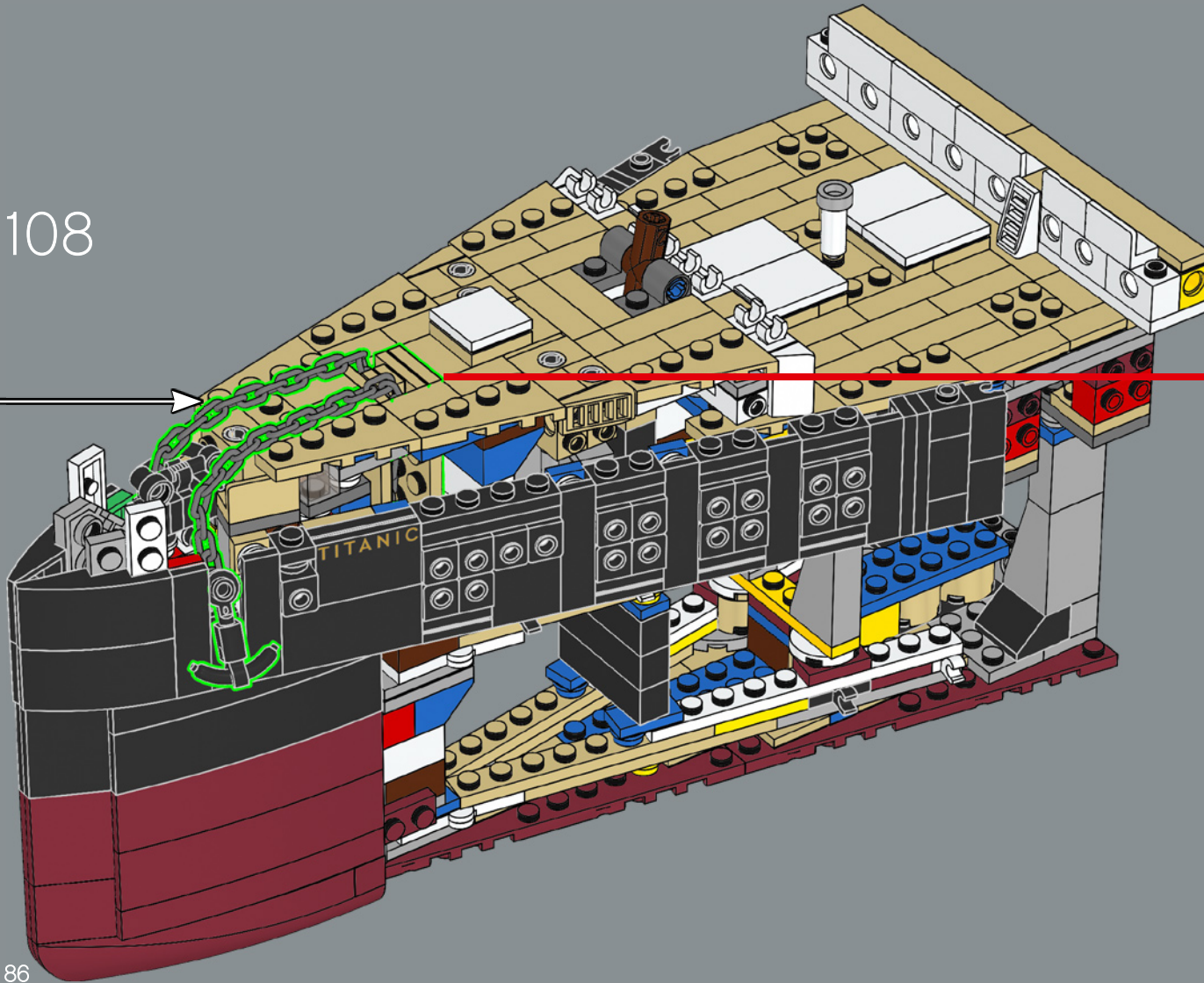

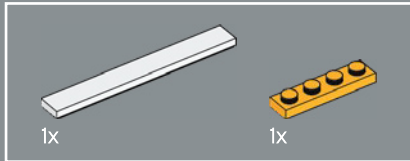
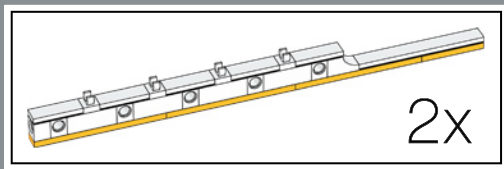

109

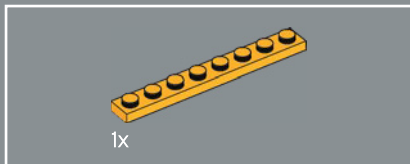
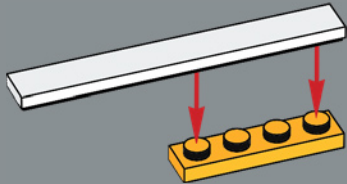

110

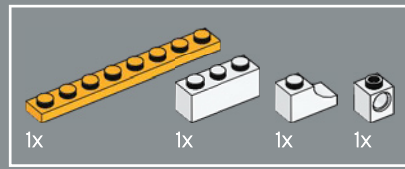
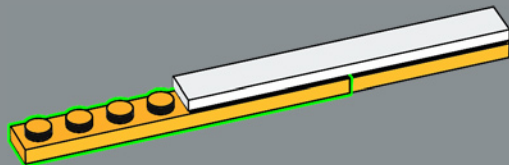

111

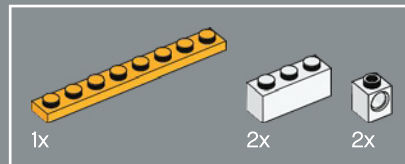
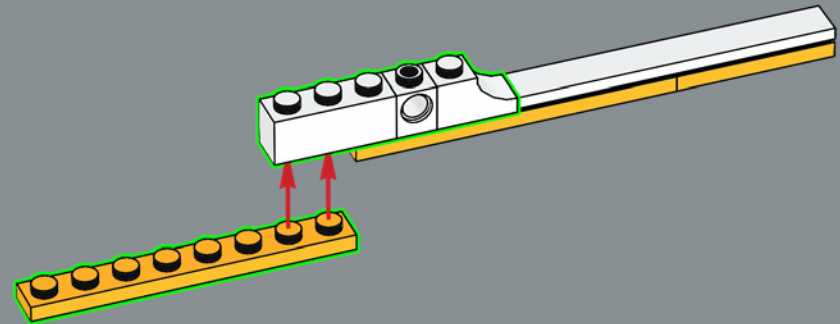

112

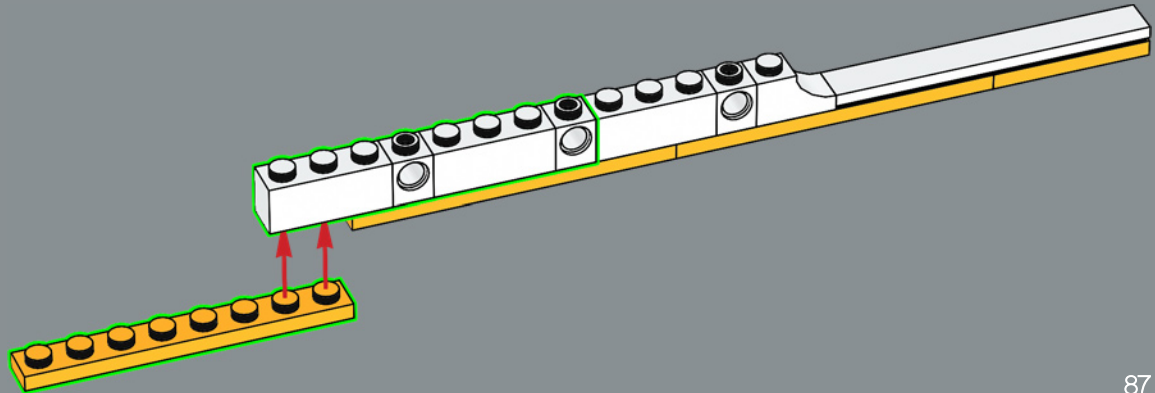

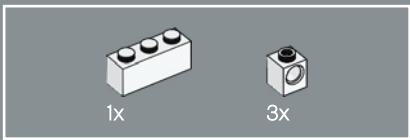

113

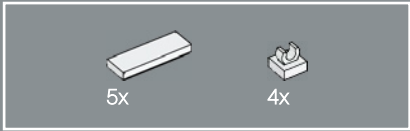
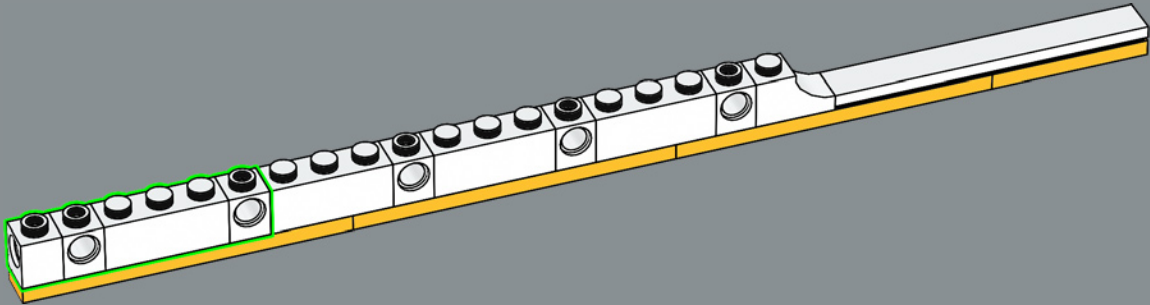

114

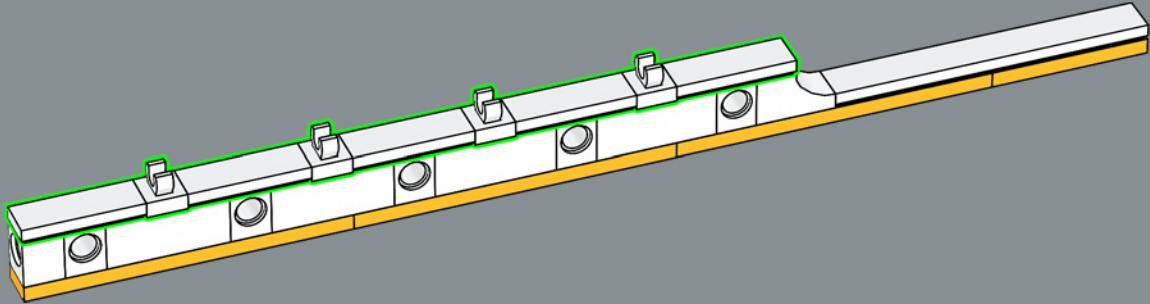

2x



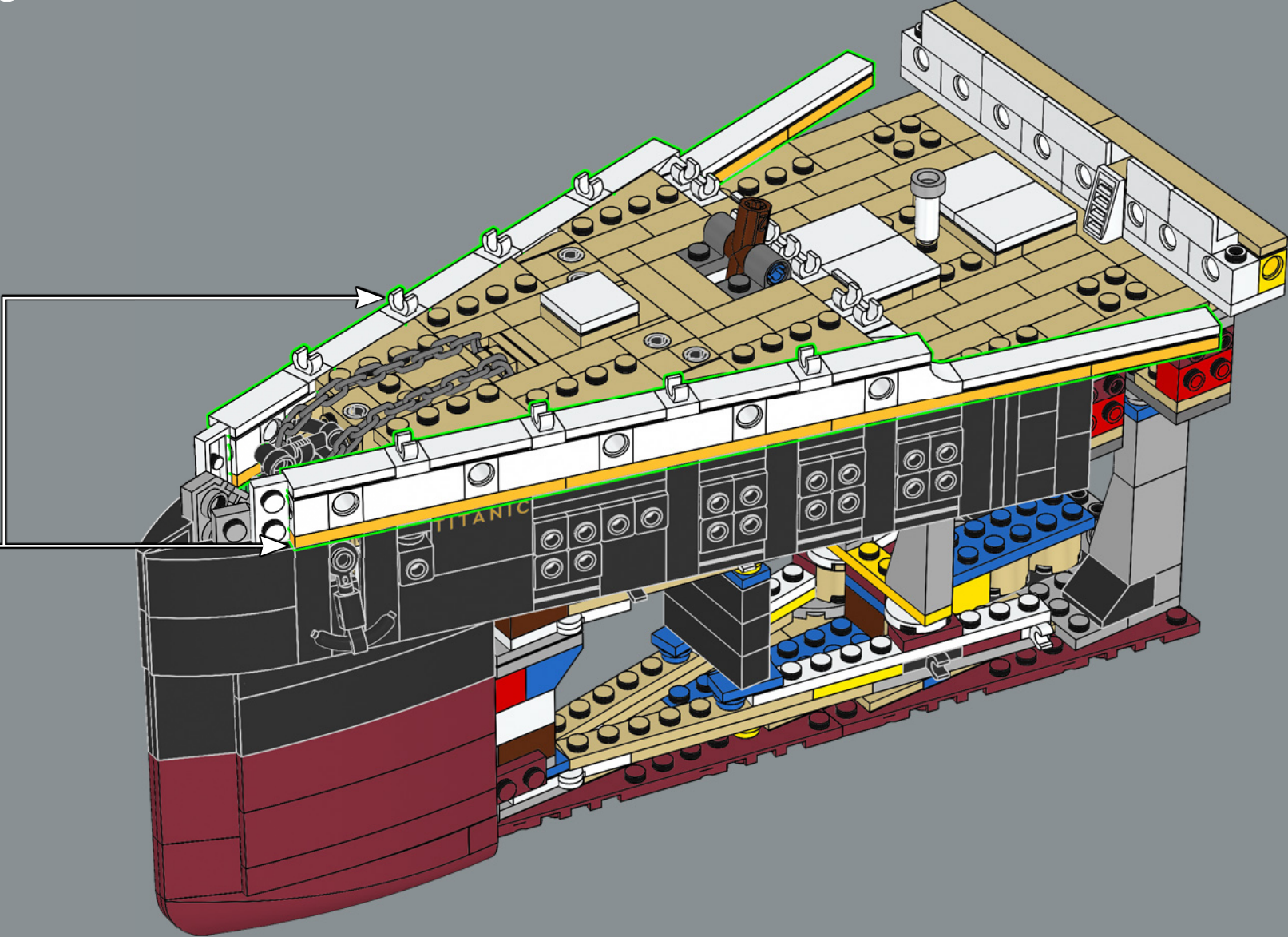

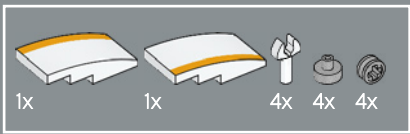

116

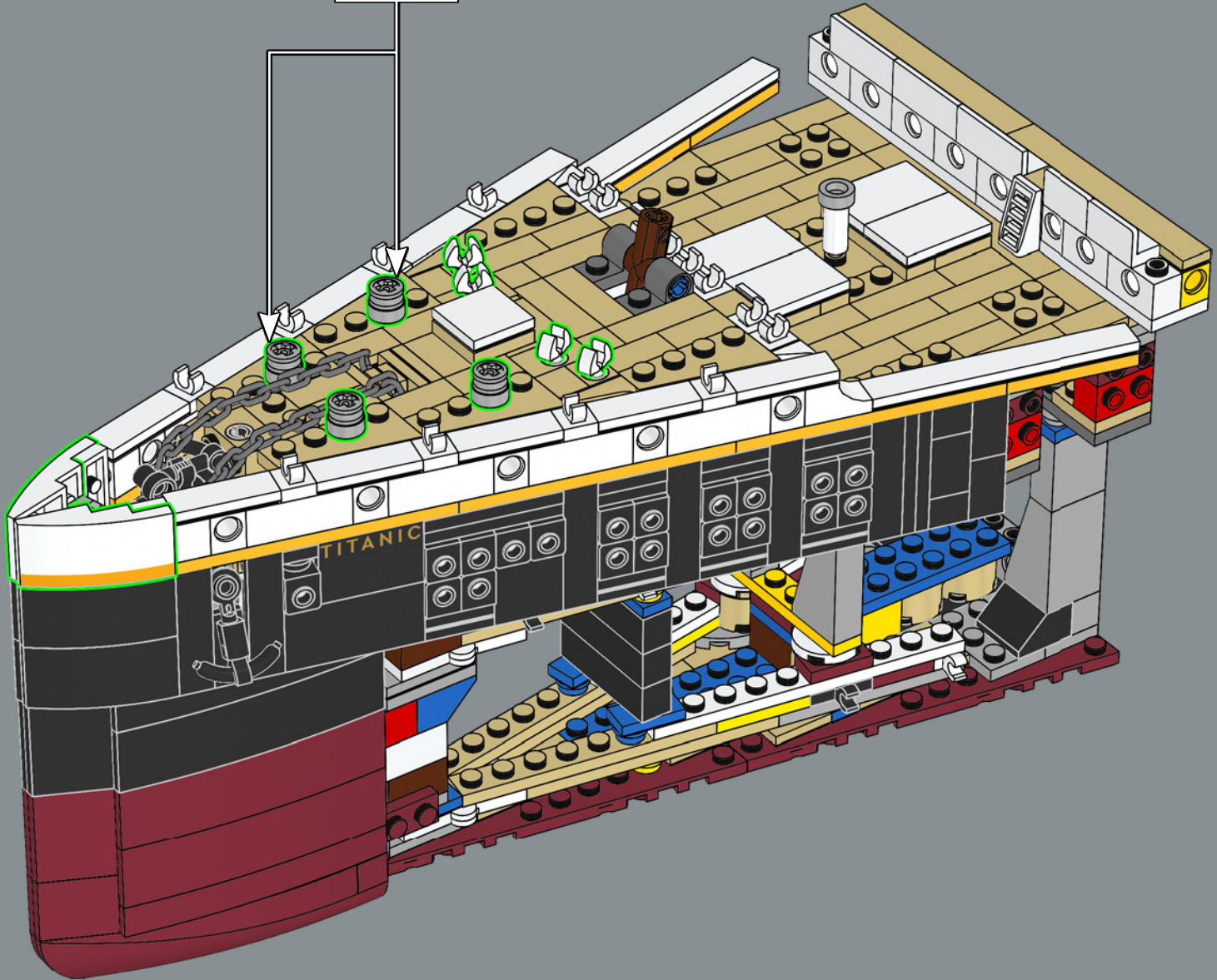
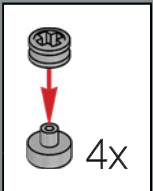

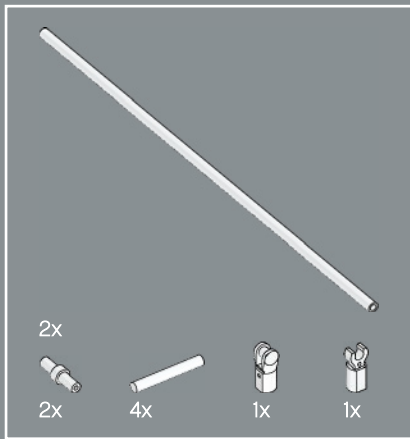

117

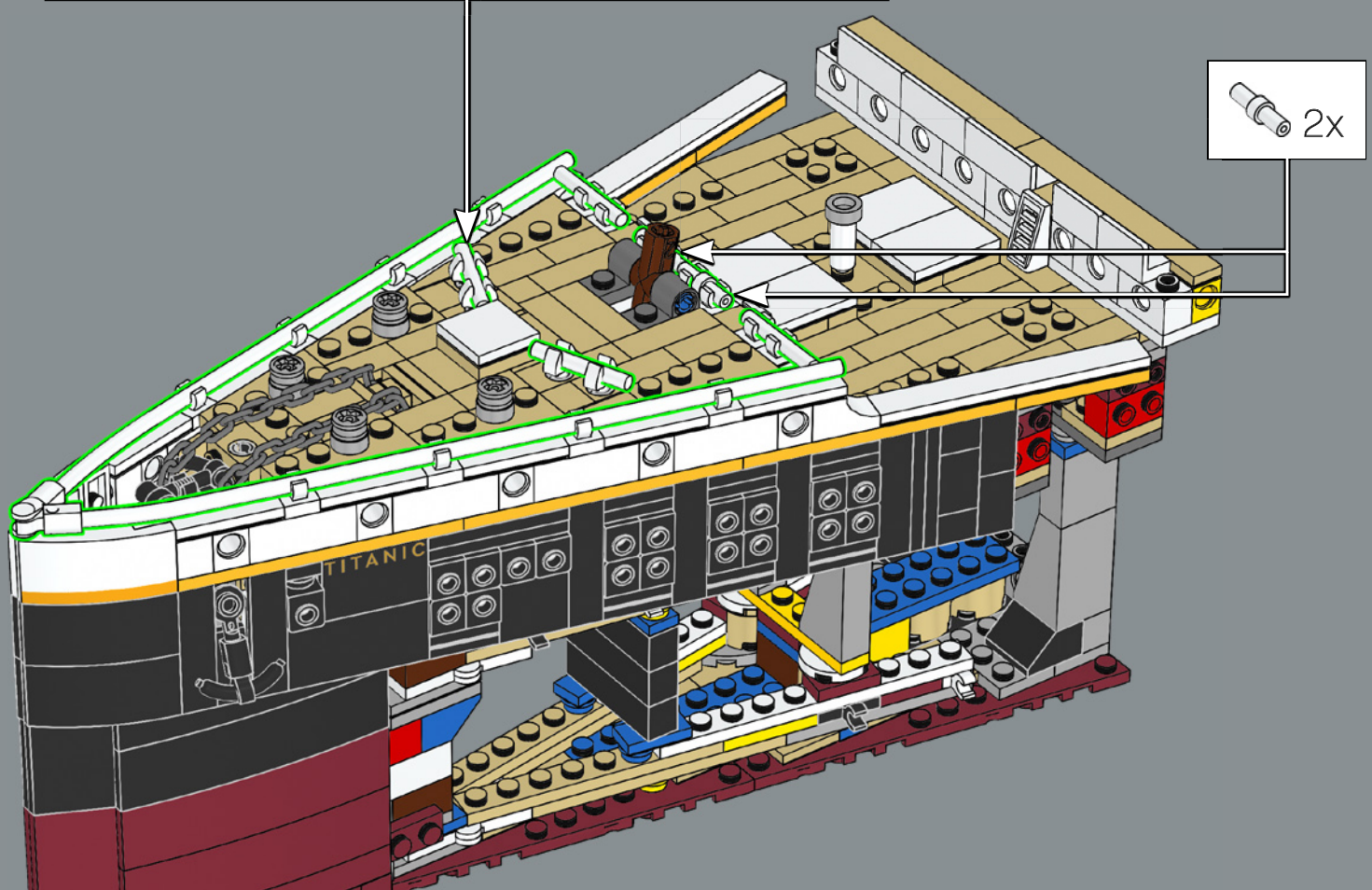
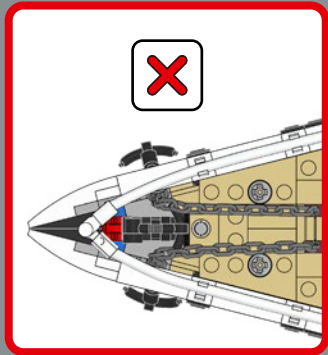
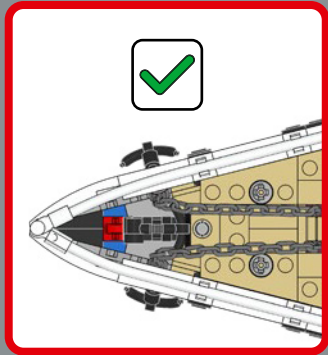
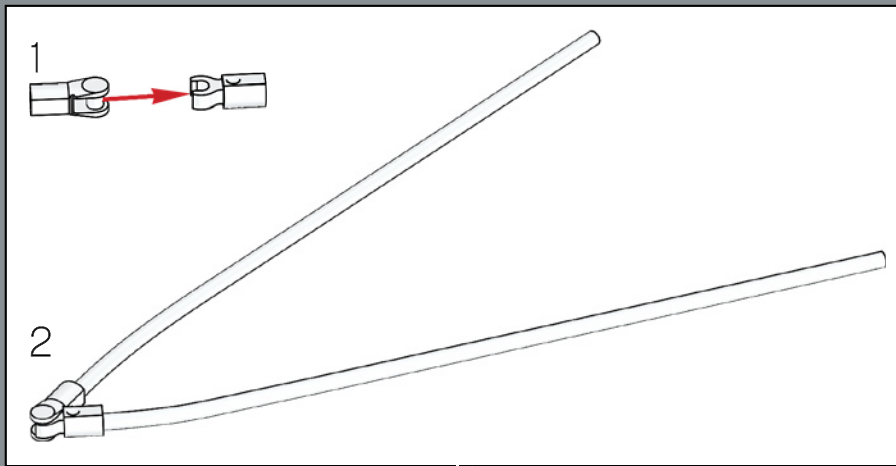



118

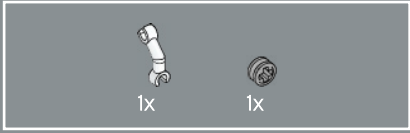

119



120

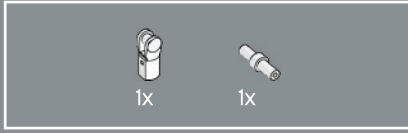
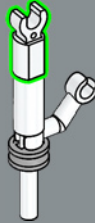

121

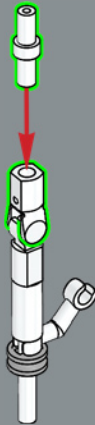



122

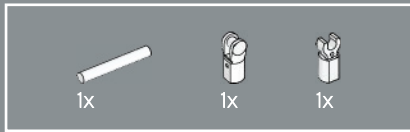
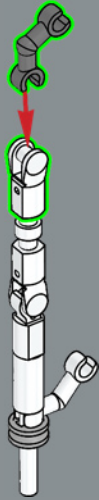

123

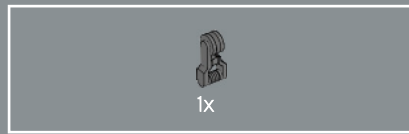
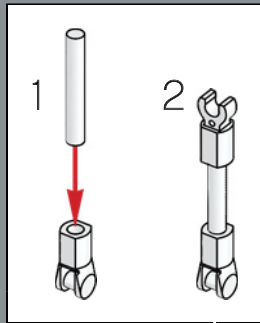
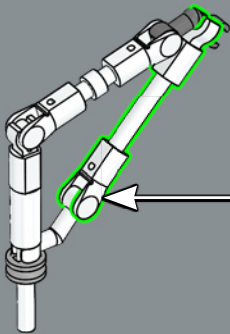

124

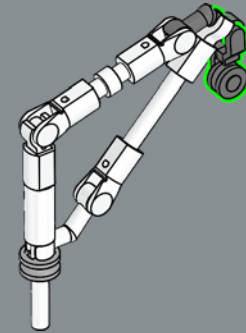

125

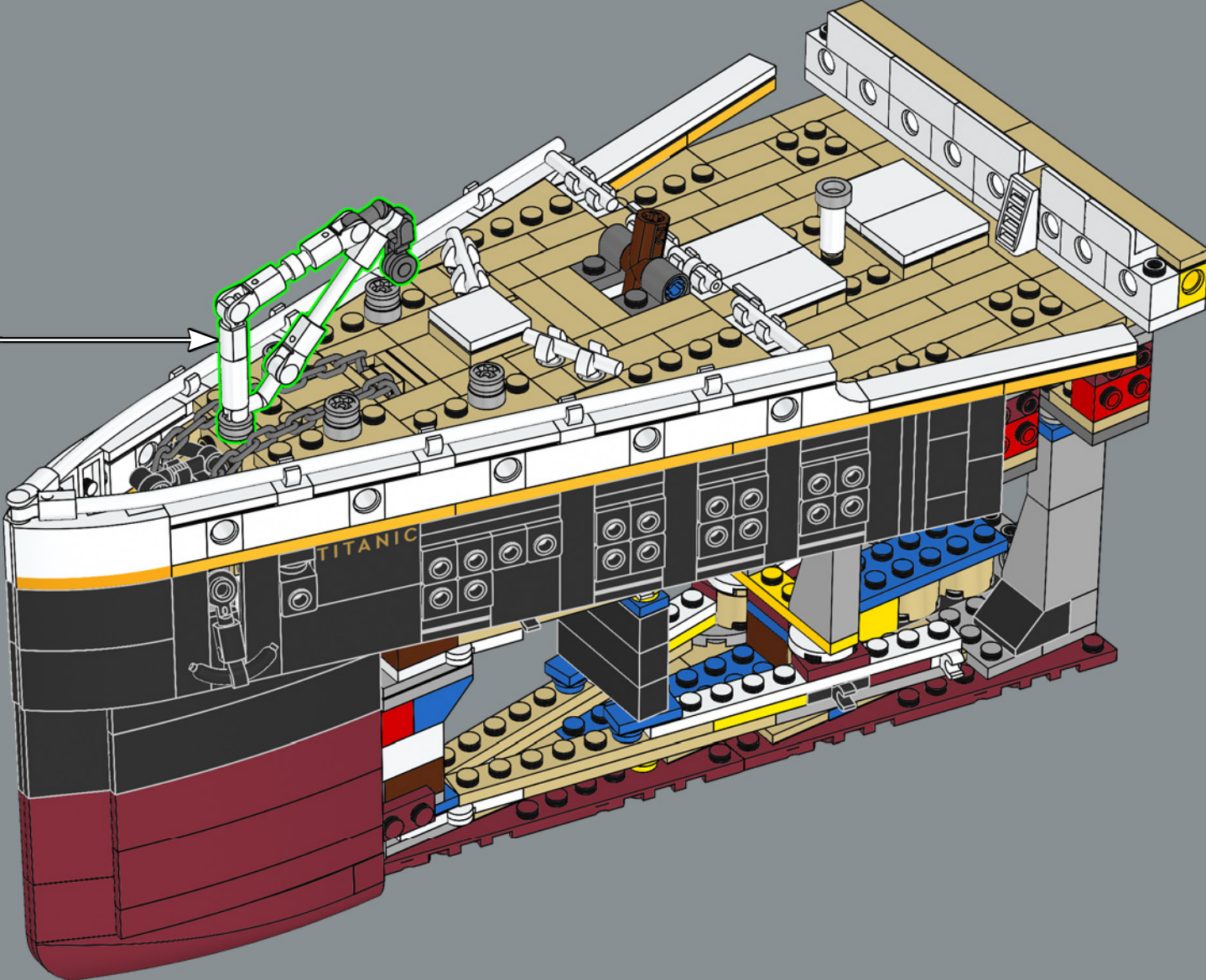

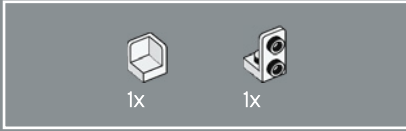
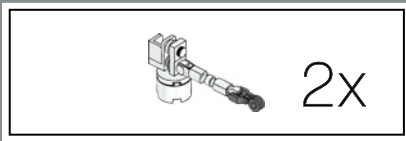

126

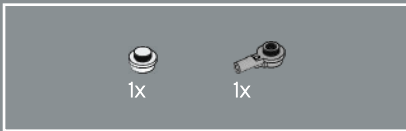

127

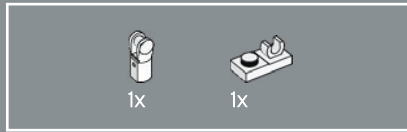

128

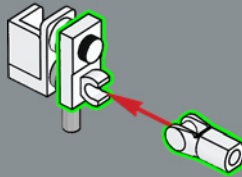

129

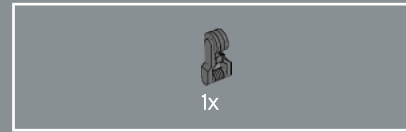
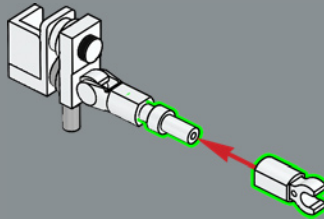

130

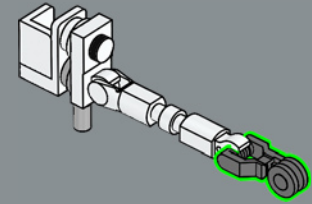

131

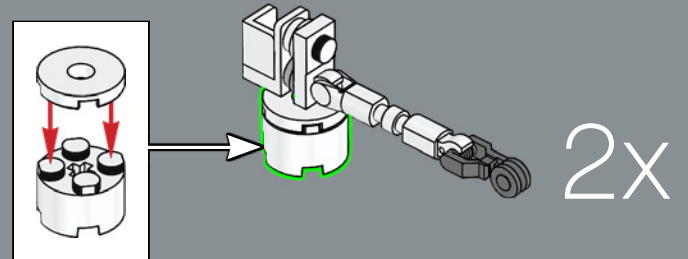

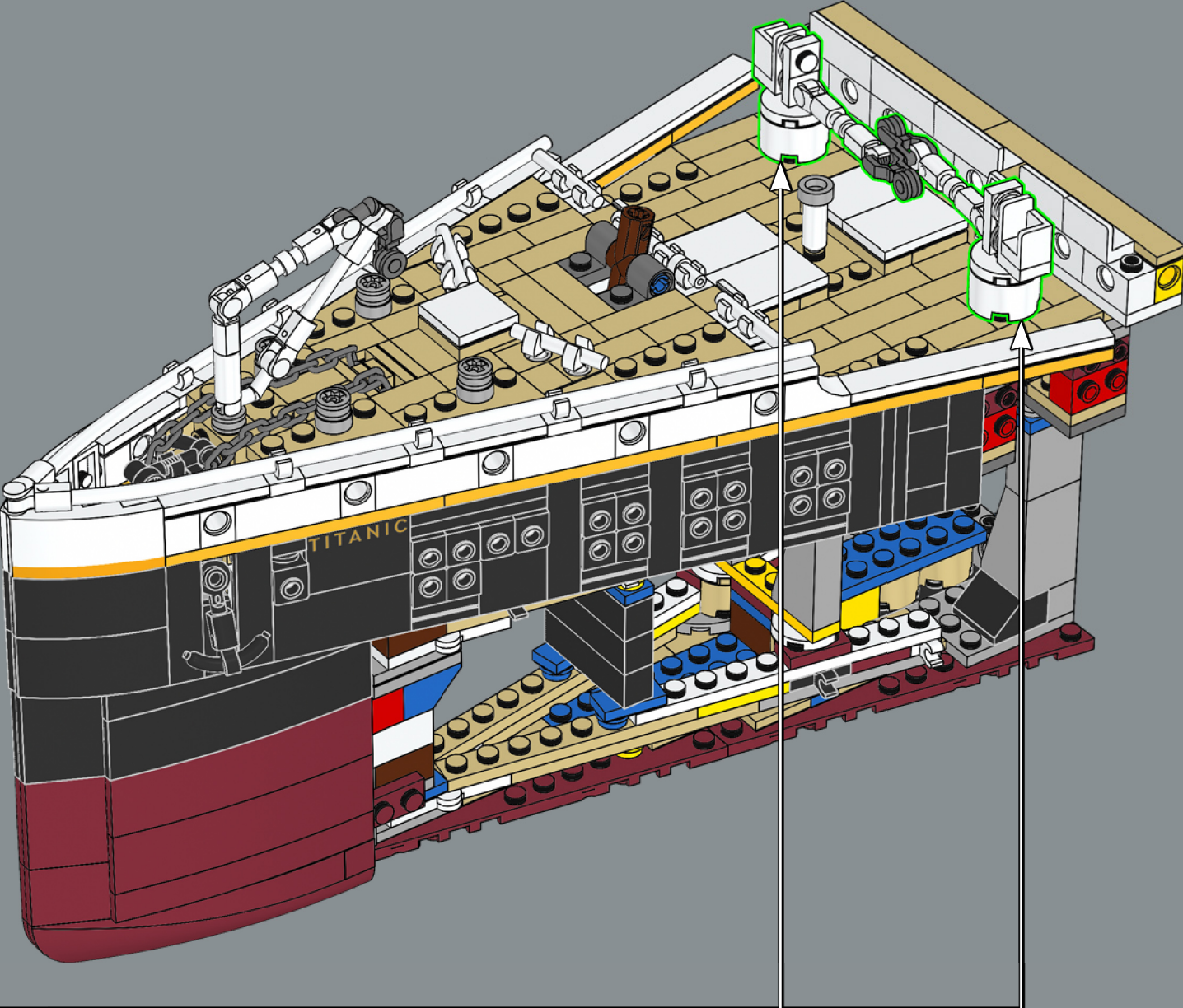



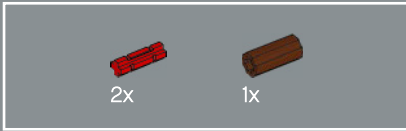
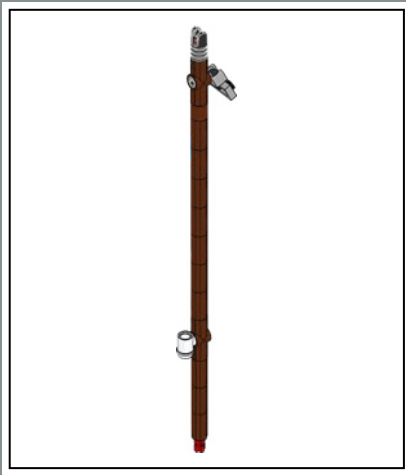

133



134

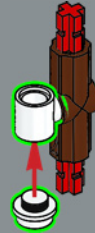

135

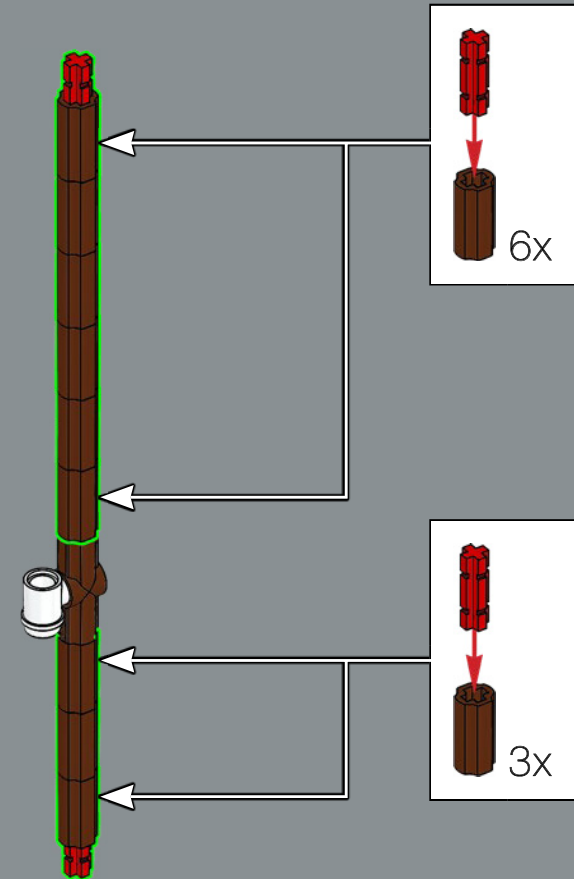

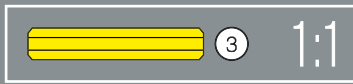
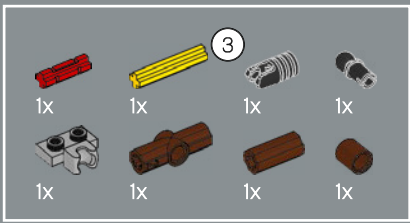

136

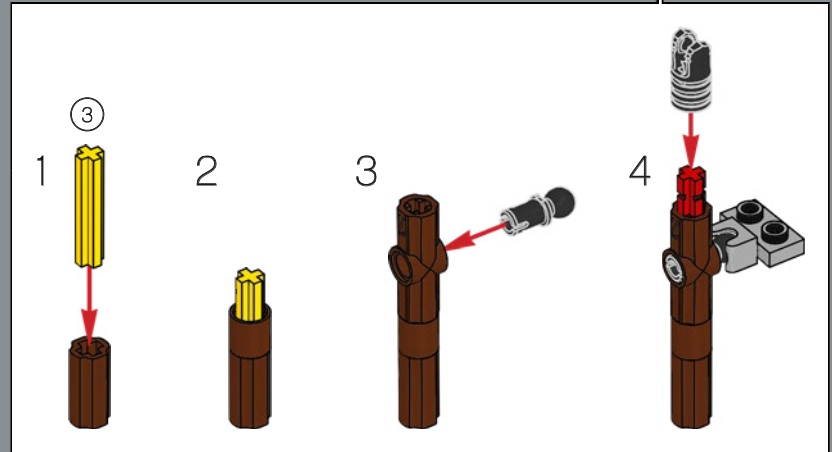

137

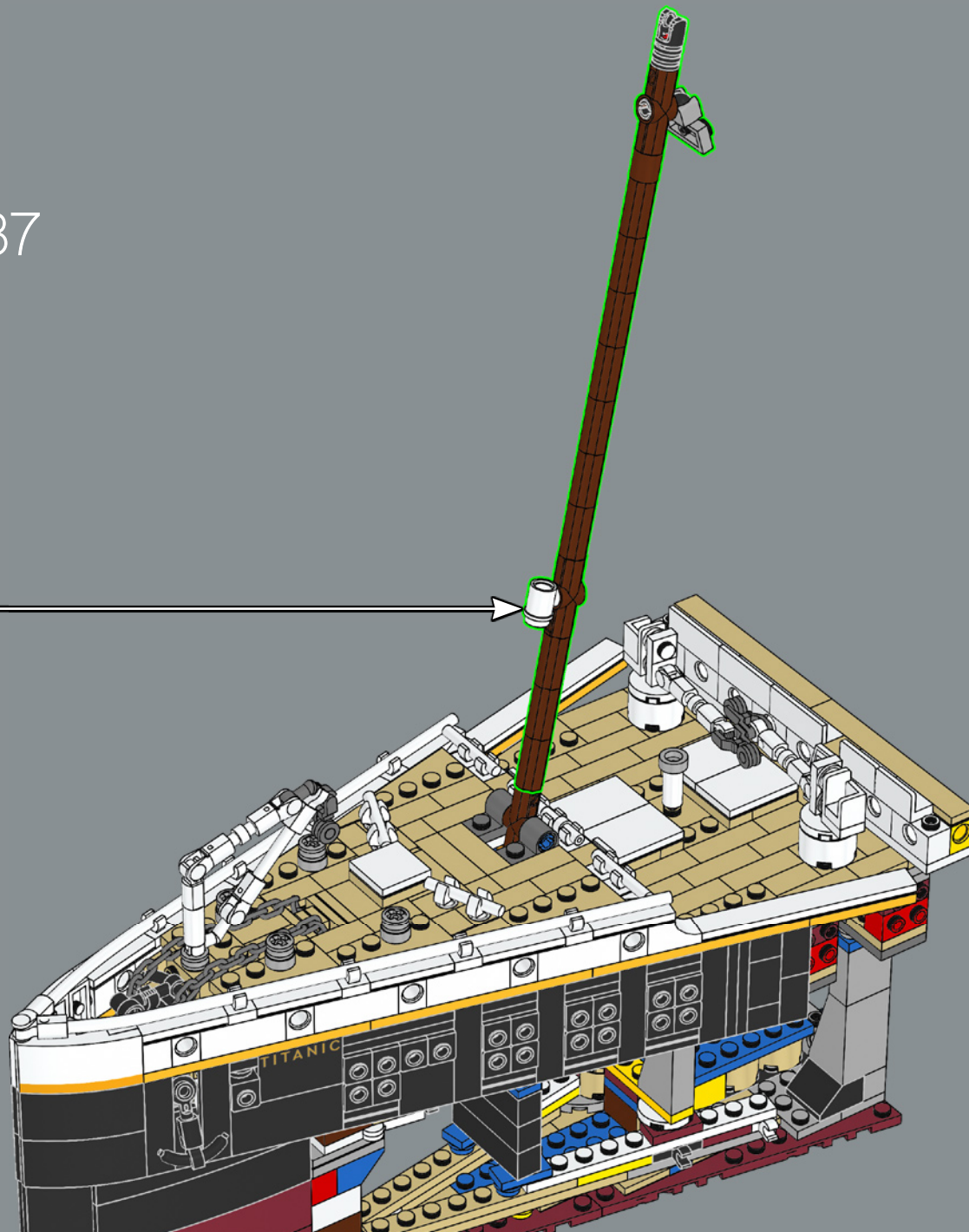

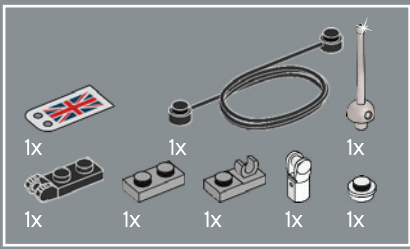

138

1

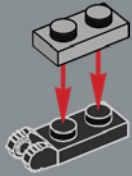

2

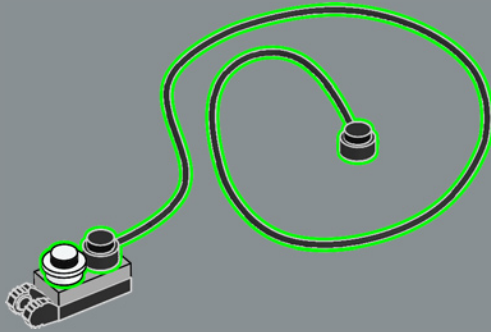

3

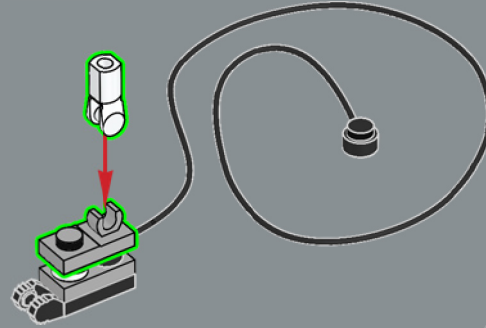

4

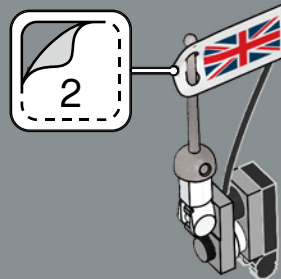

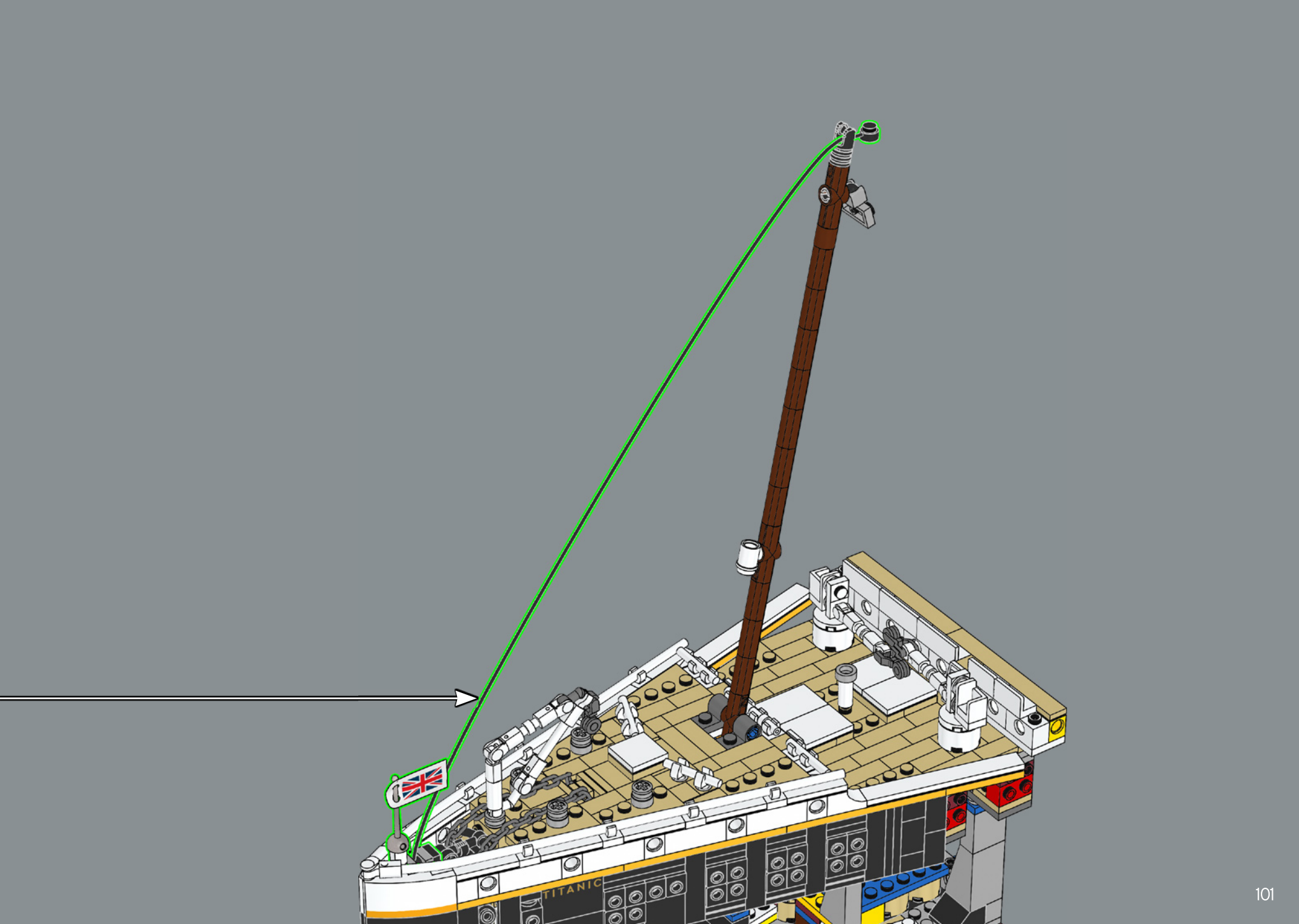

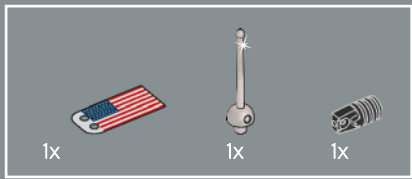

139

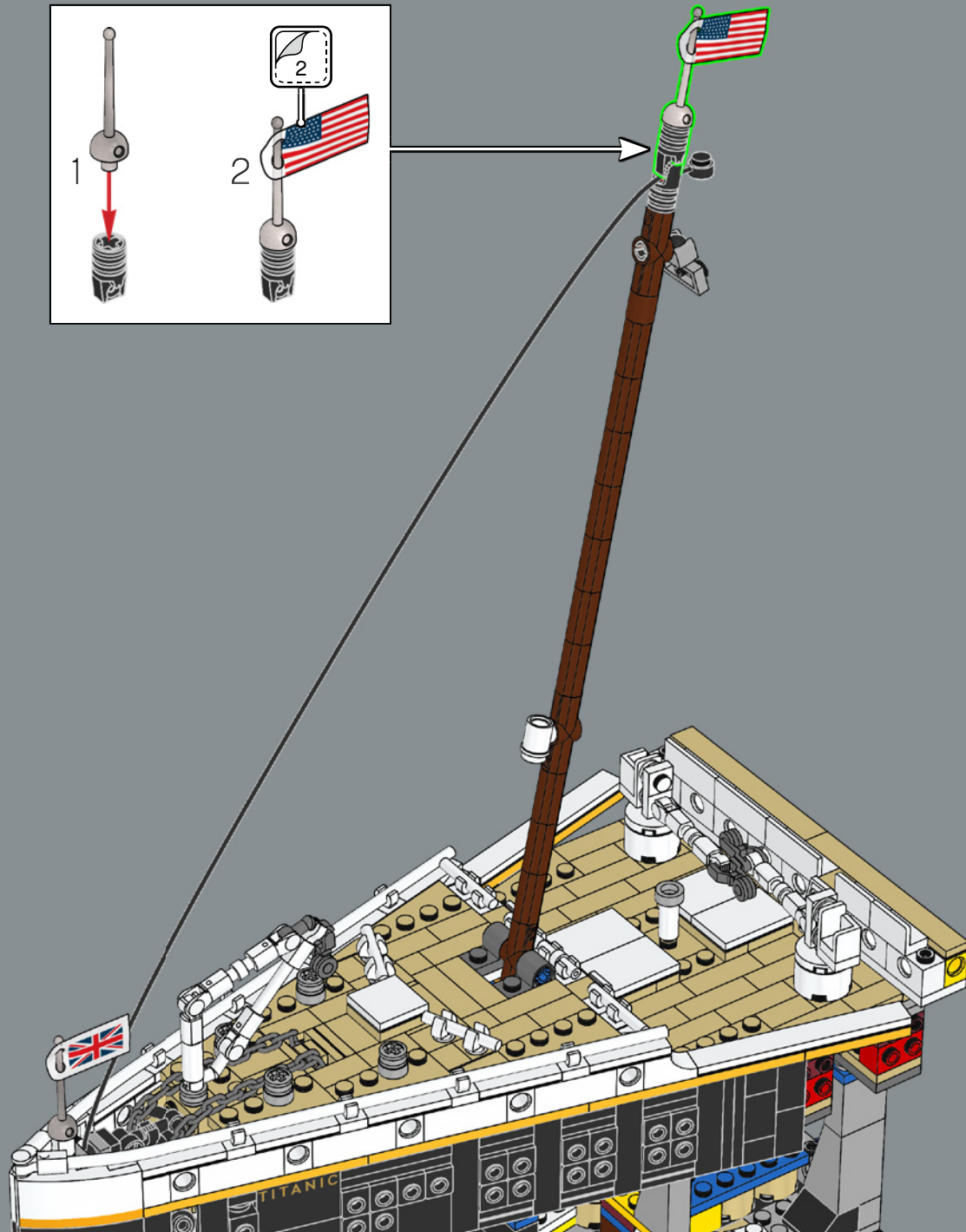
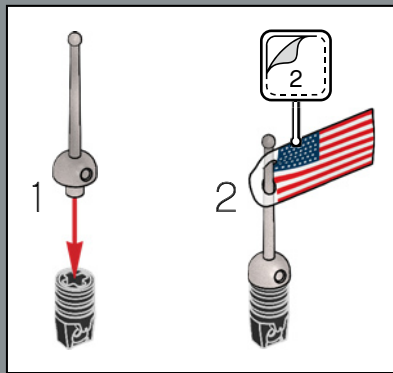

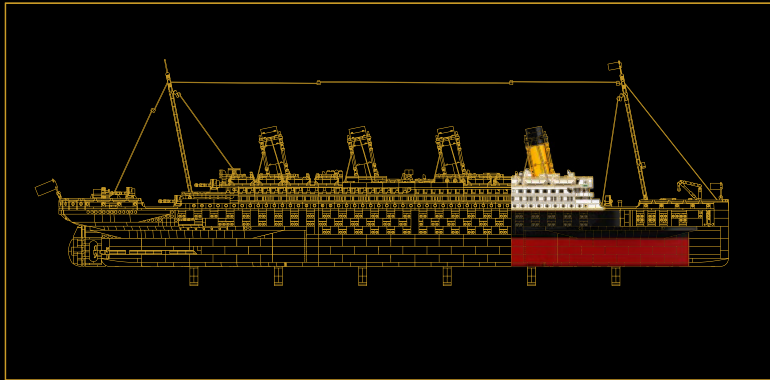

ABSCHNITT 2:

## BRÜCKE & SCHORNSTEIN

In diesem zweiten Abschnitt erreicht der Rumpf seine maximale Breite von 18 Modulen, was ungefähr 144 mm entspricht. Im Inneren des Rumpfes beginnst du mit dem Bau des Querschnitts. Das schließt auch einen Teil des Schwimmbeckens, das große Treppenhaus und einen der Kesselräume der Titanic ein. Außerdem baust du in diesem Abschnitt die legendäre Brücke und den ersten von vier Schornsteinen.

↓ Ein im großen Treppenhaus verborgener Verriegelungsmechanismus hält das ganze Schiff fest zusammen.



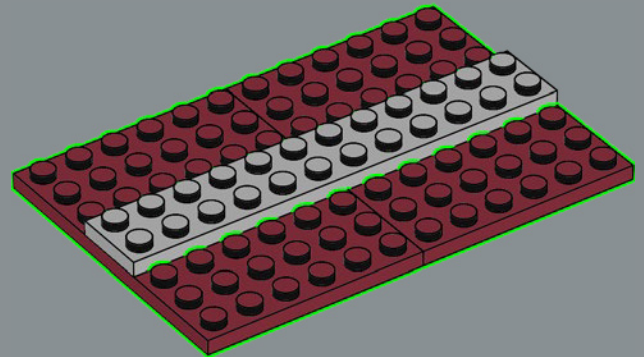
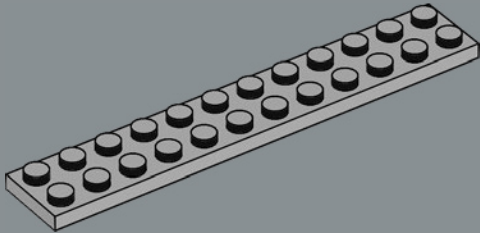
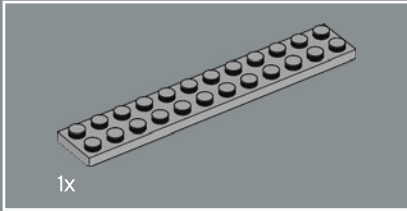
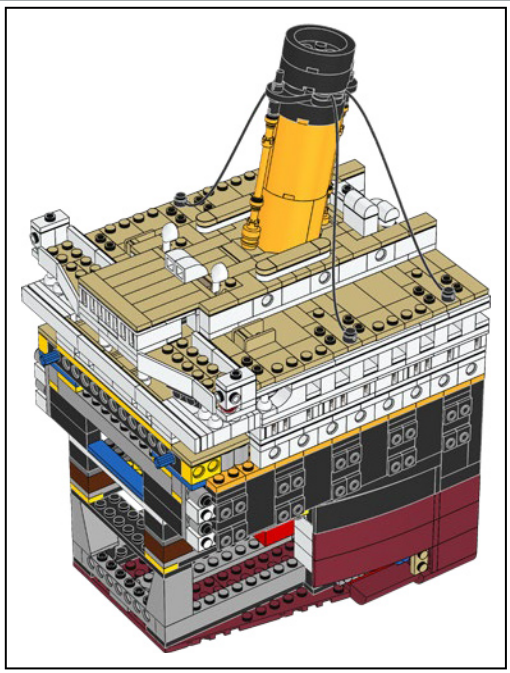
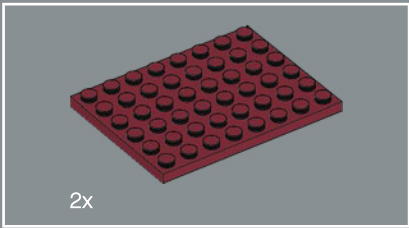
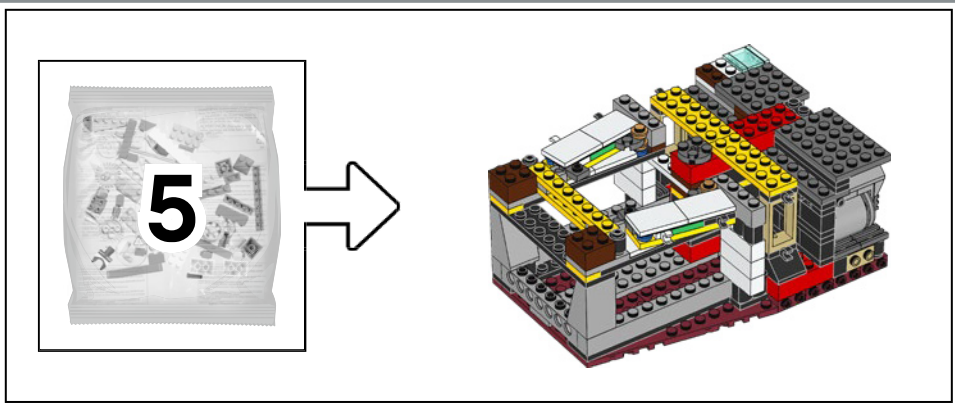



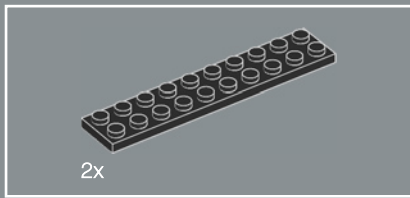

142

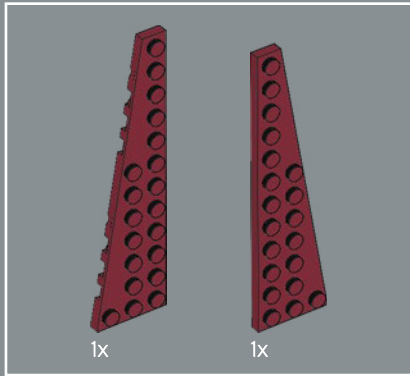
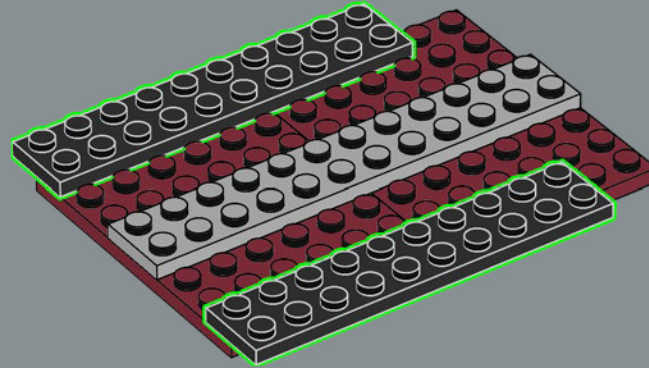

143

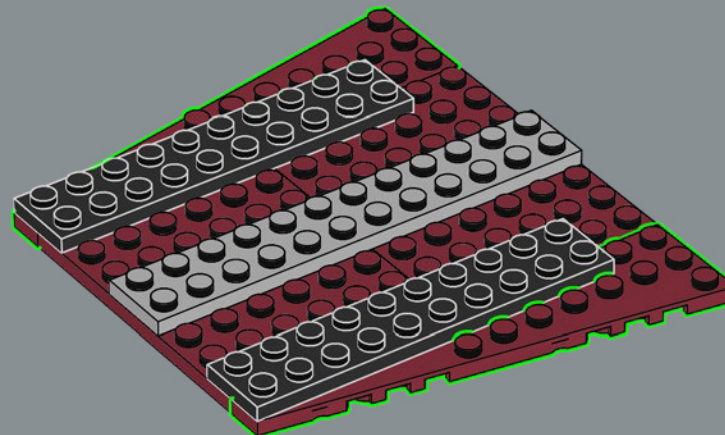

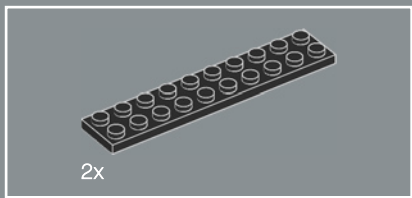

144

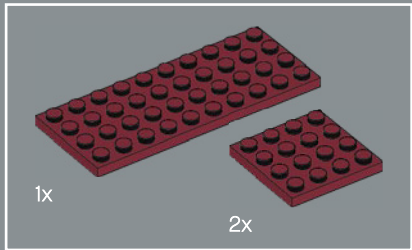
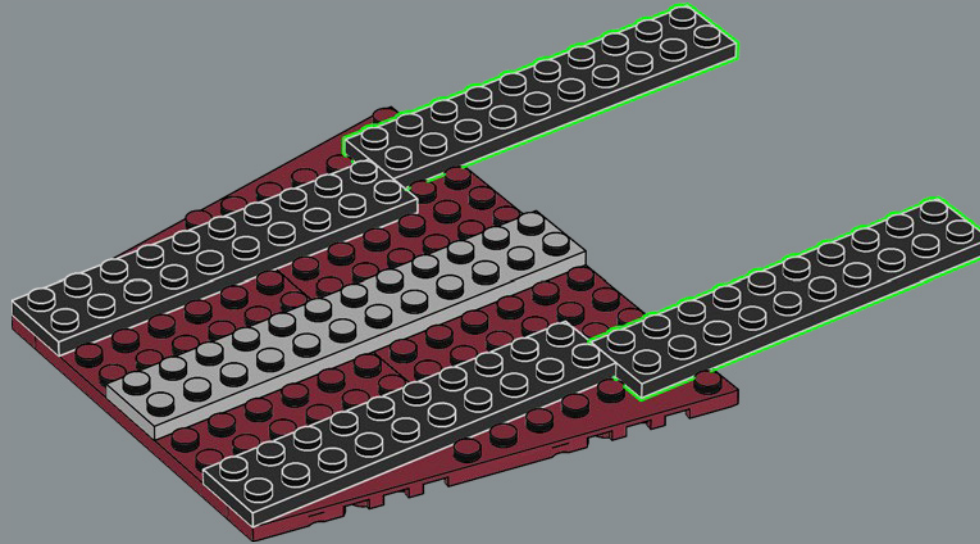

145

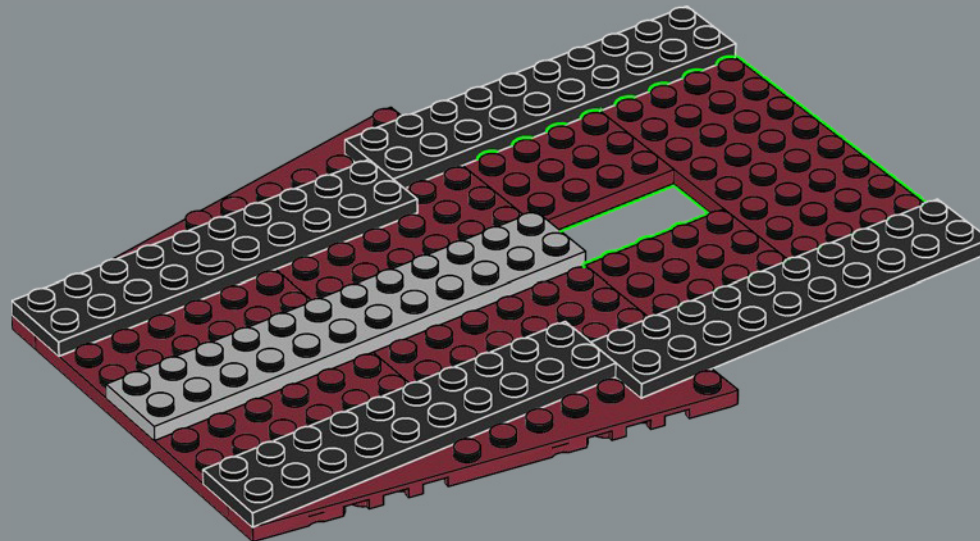

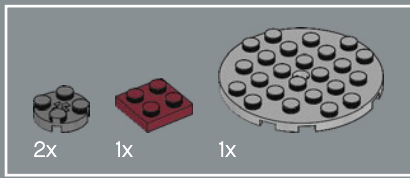

146

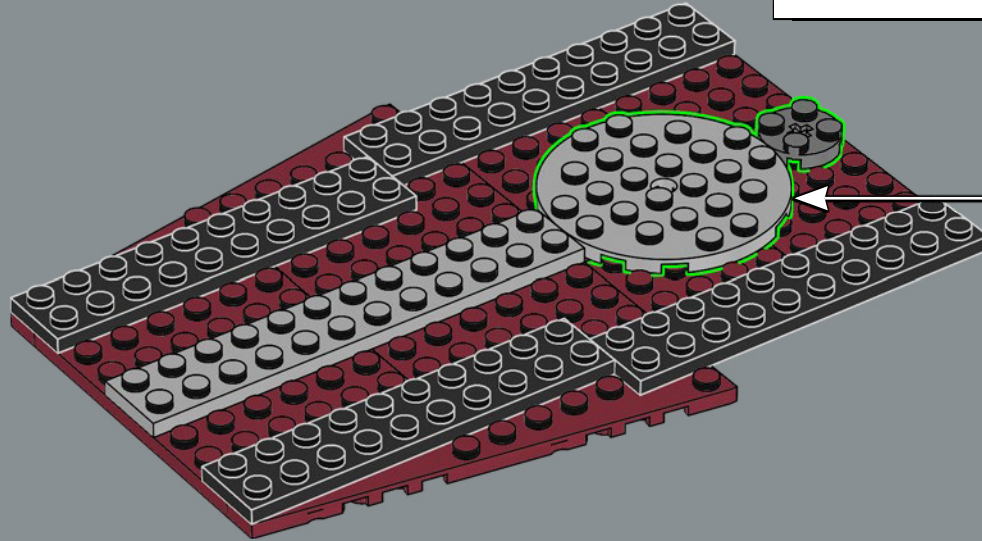

147

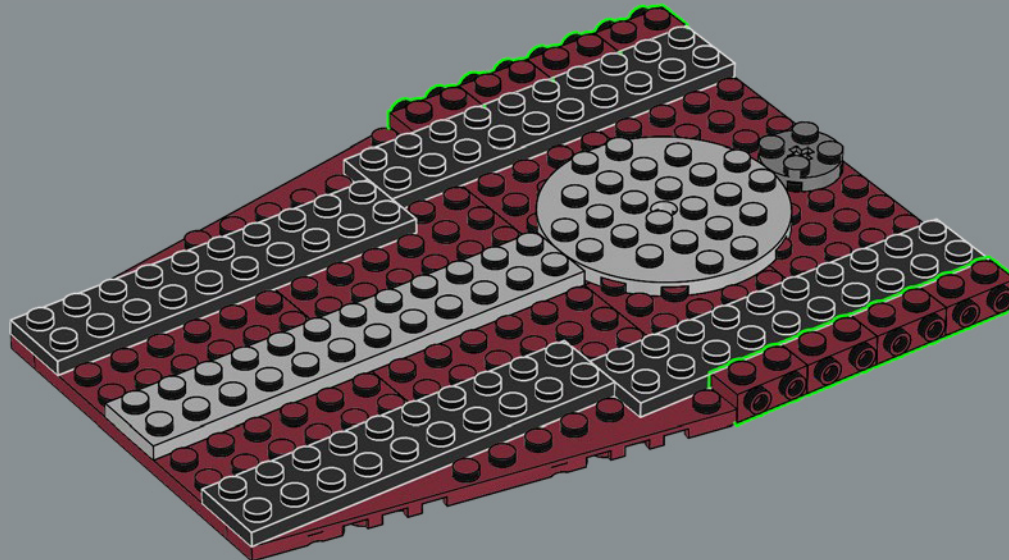



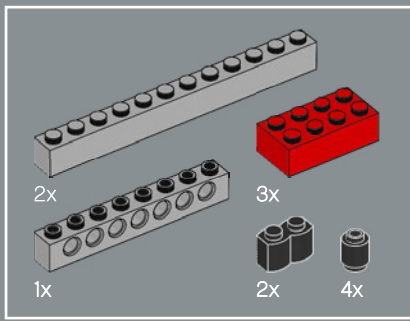

149

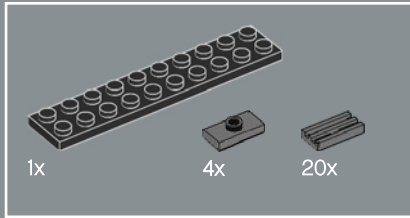
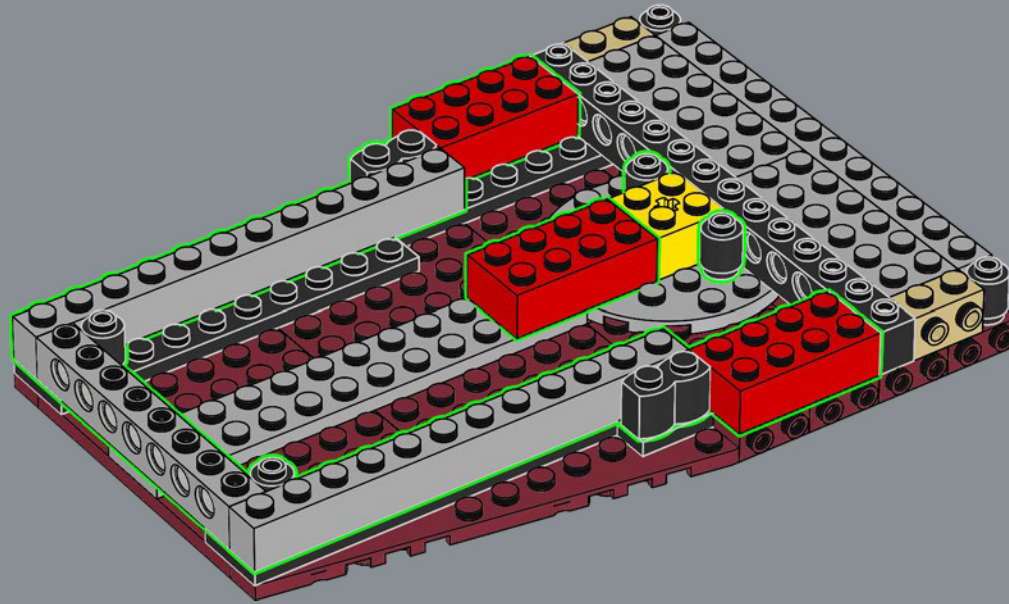

150

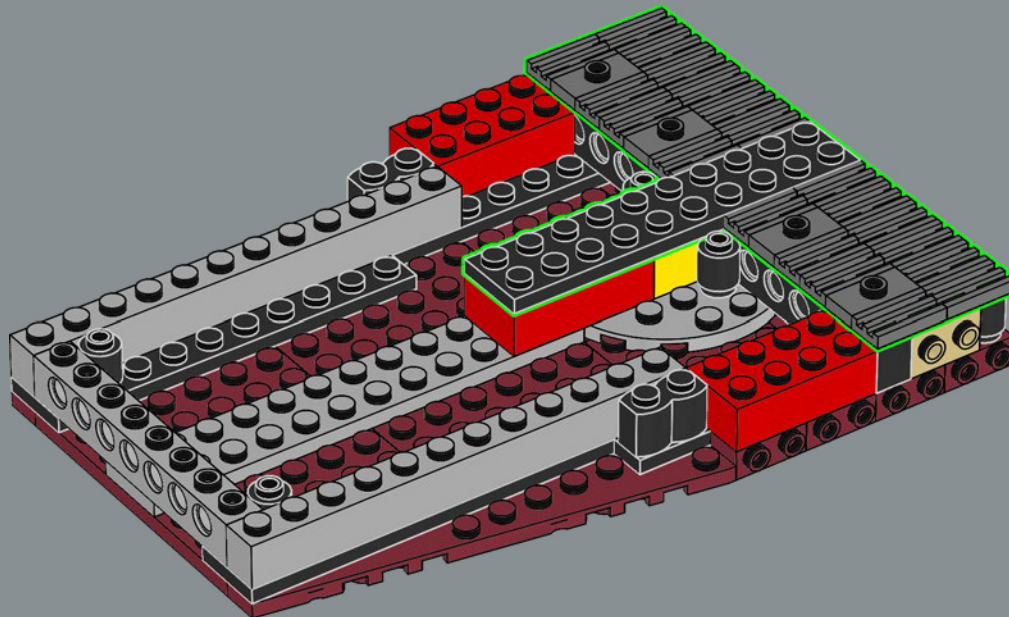

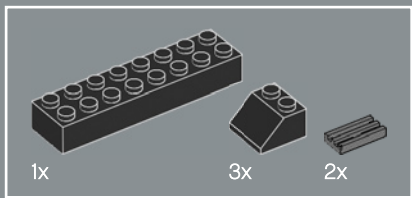

151

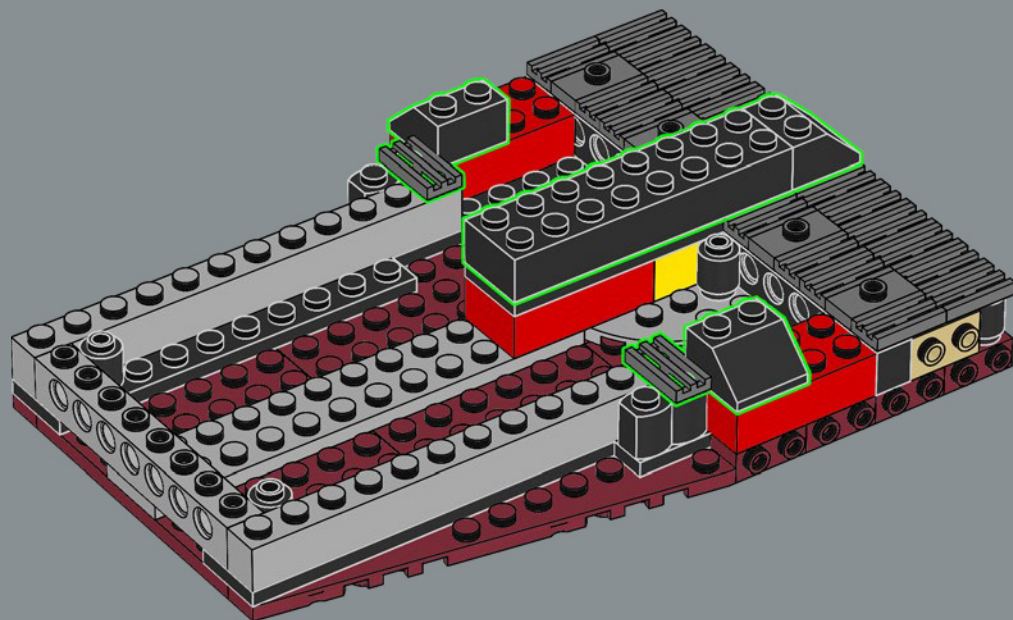

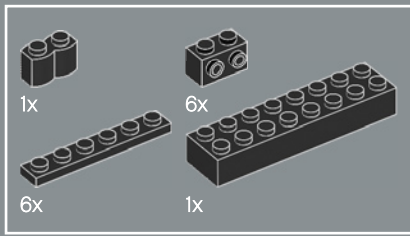

152

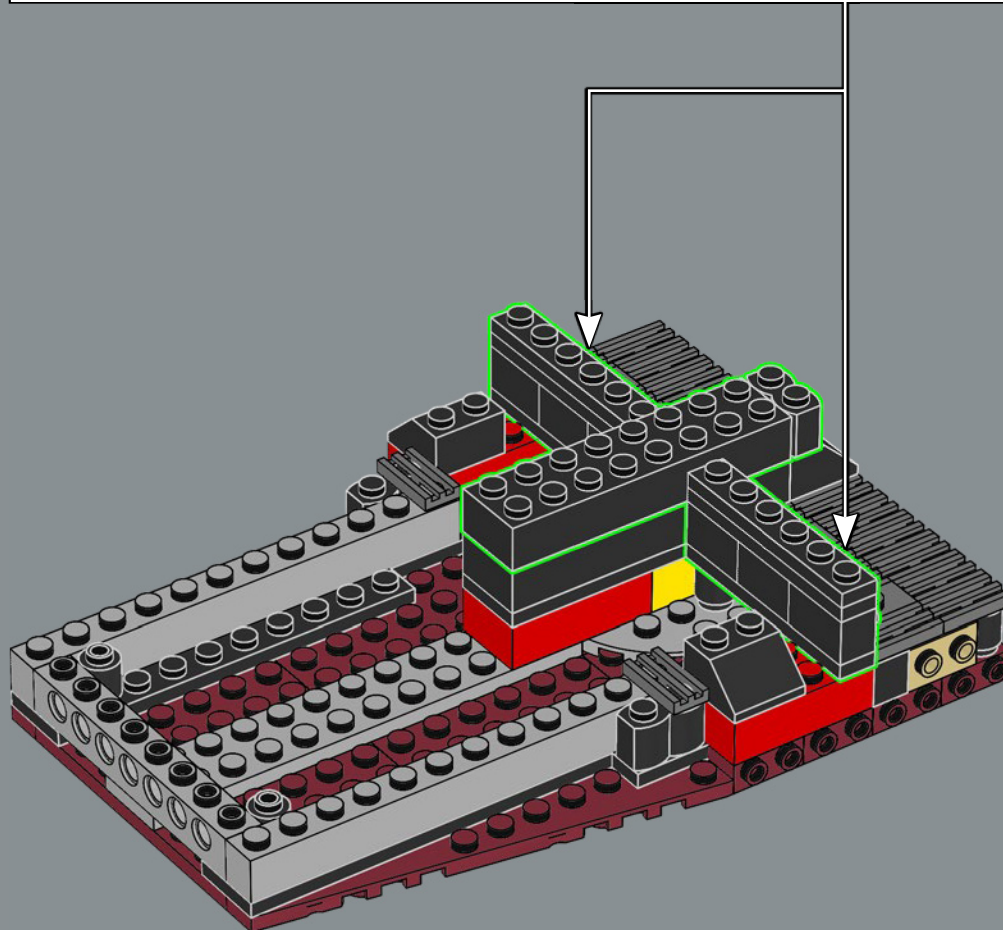
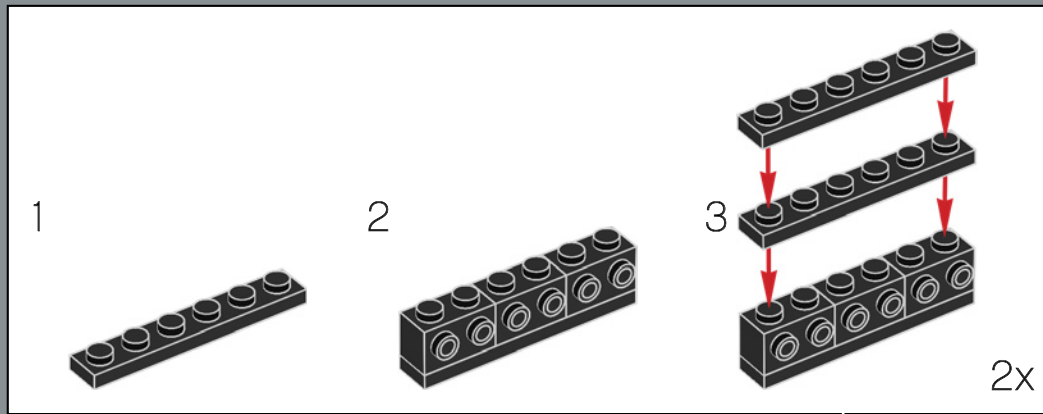

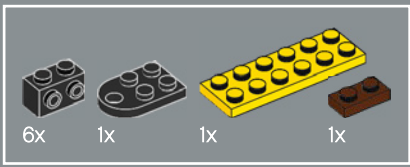

153

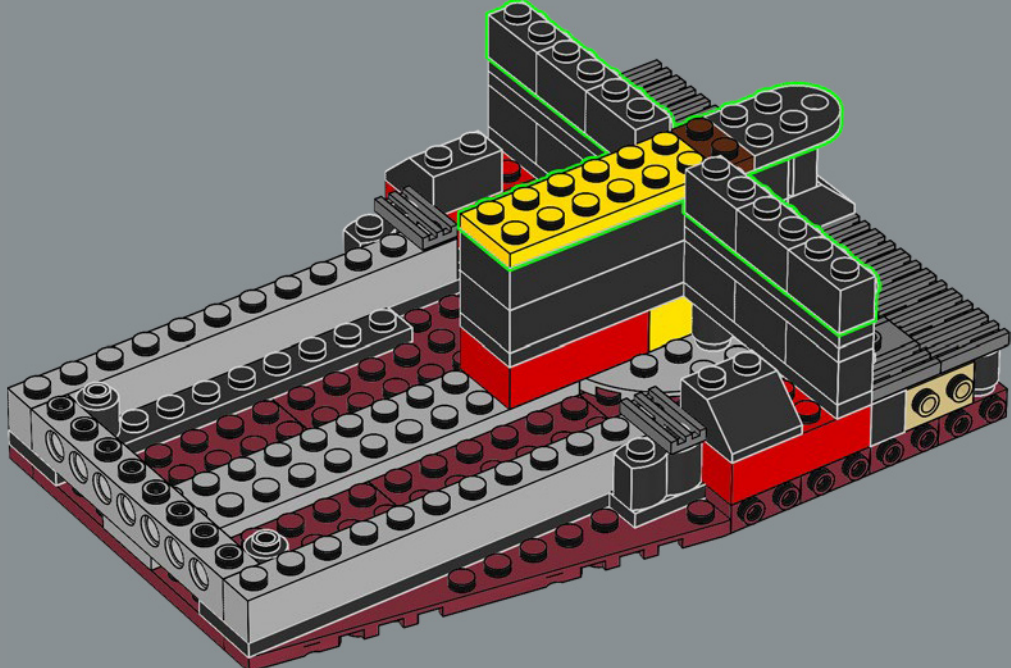



175 Heizer schaufelten rund um die Uhr Kohle in den Kessel der Dampfmaschinen.

154

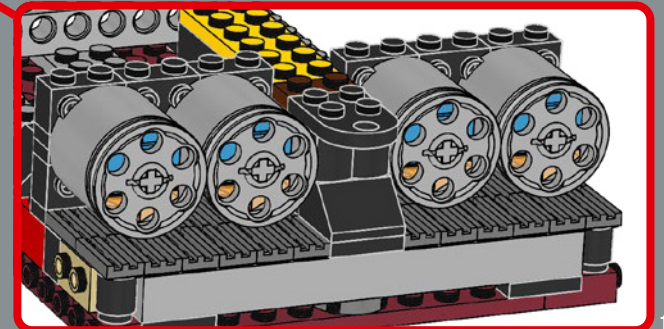
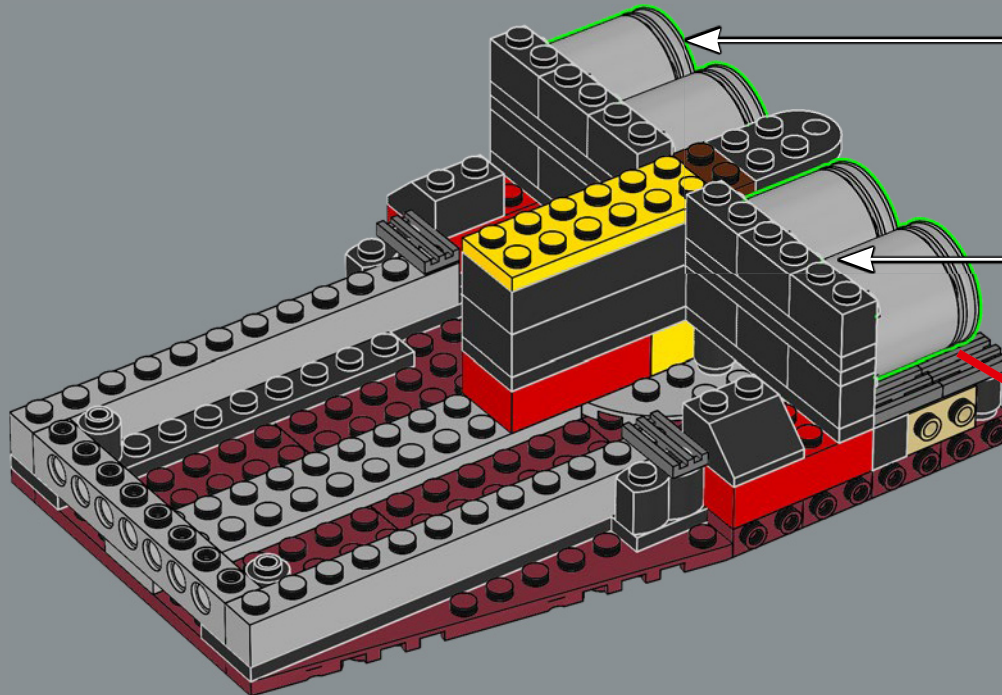
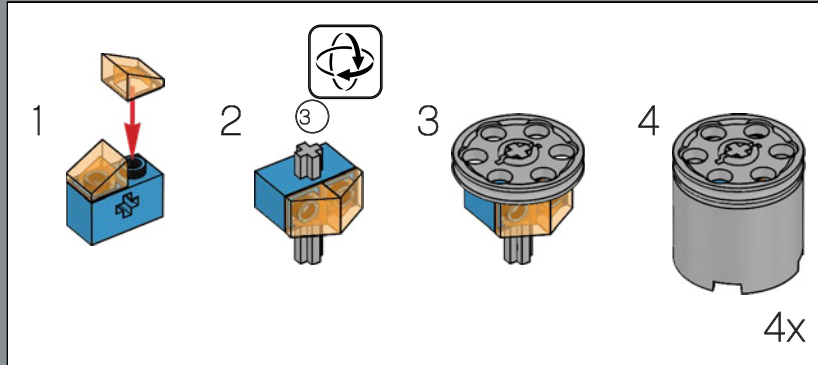
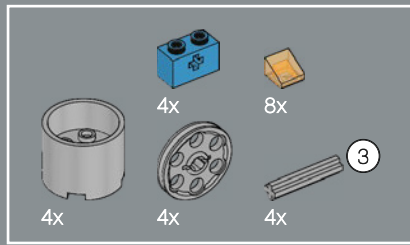



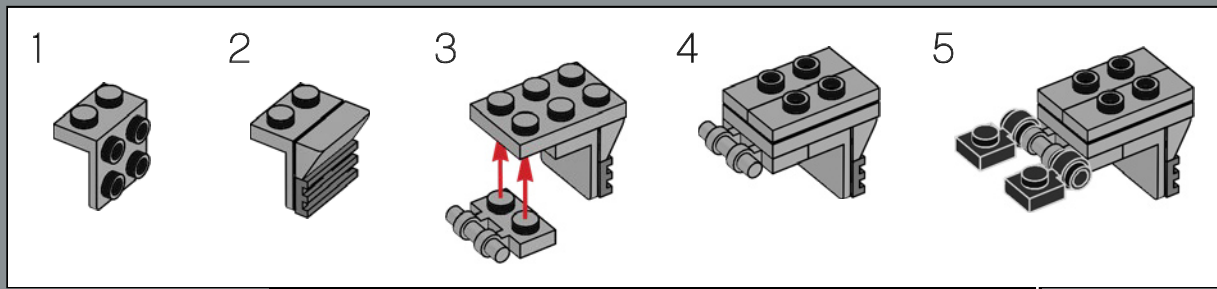
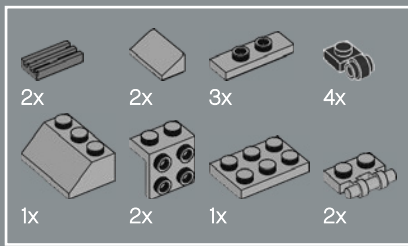

156

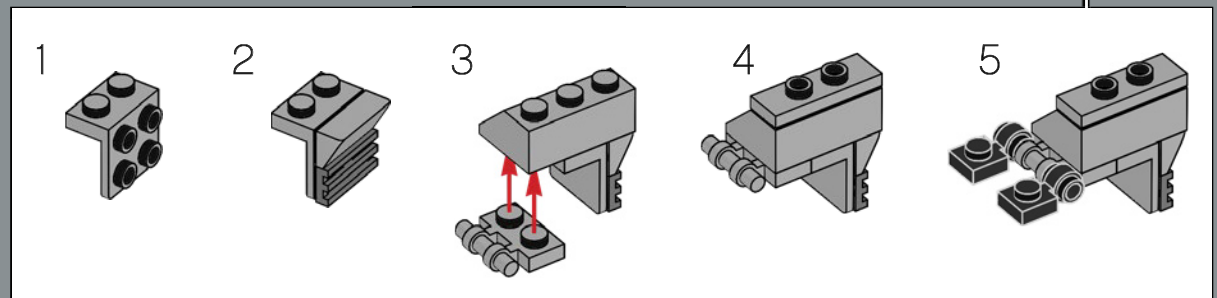
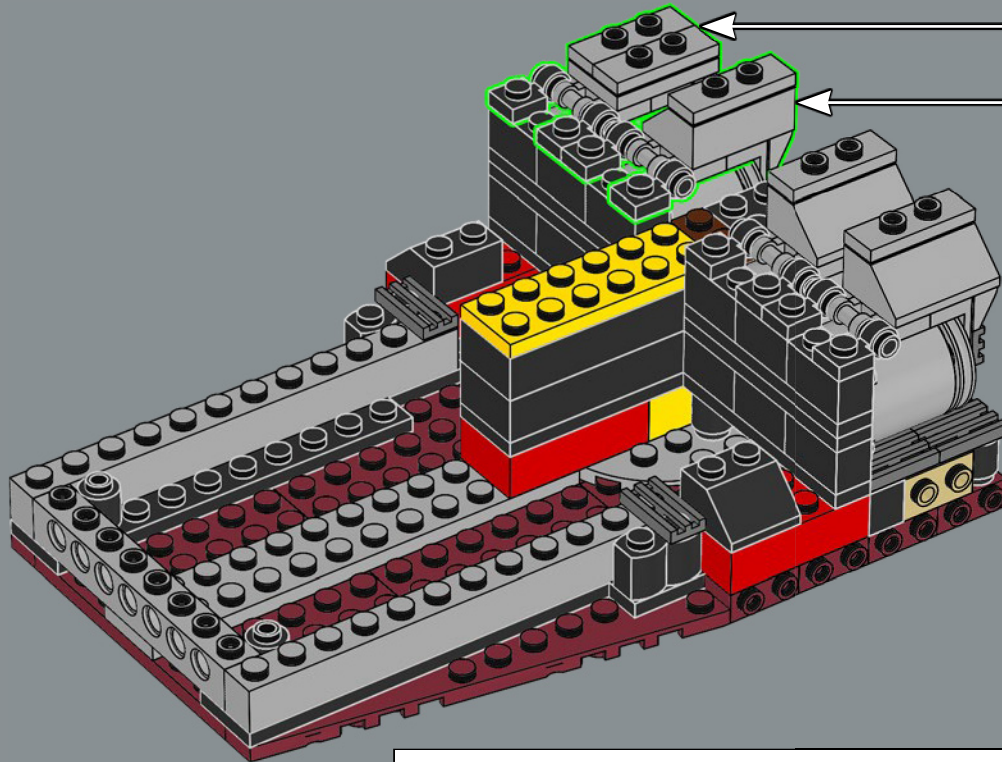

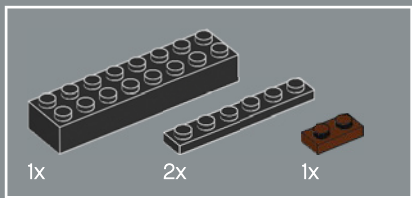

157

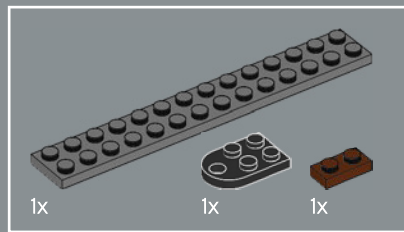
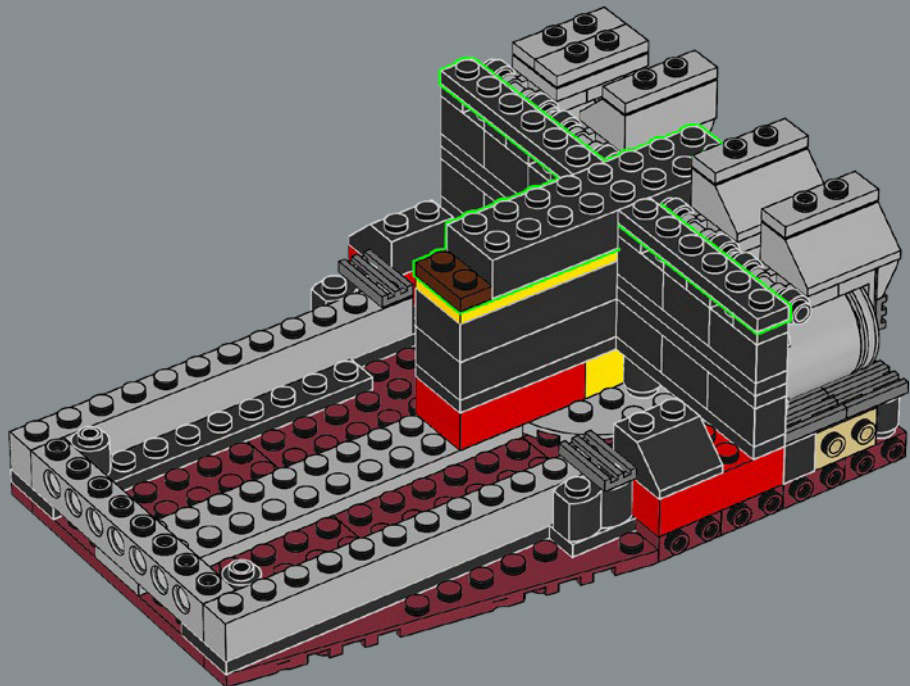

158

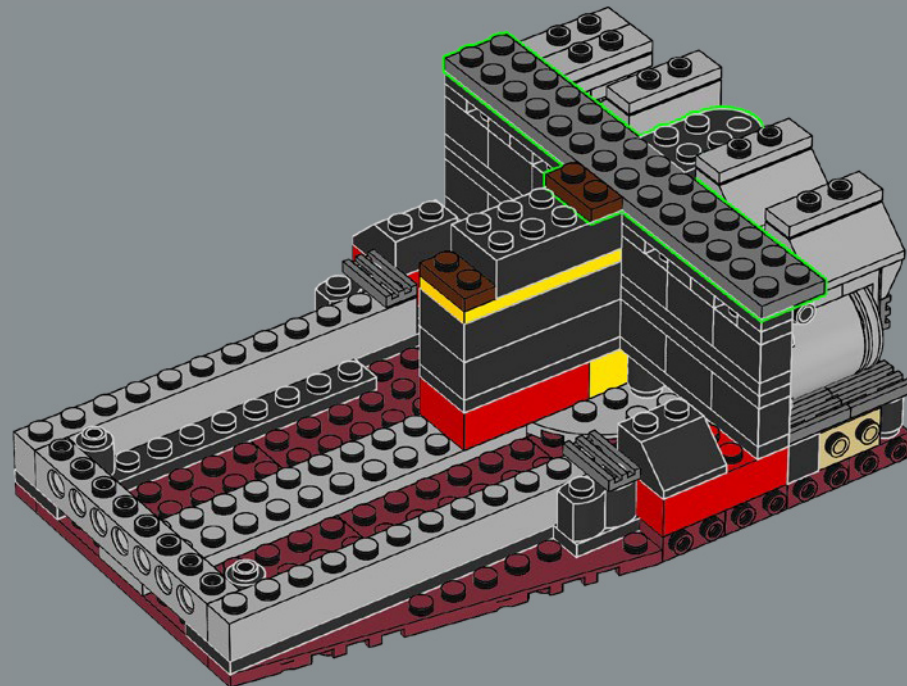

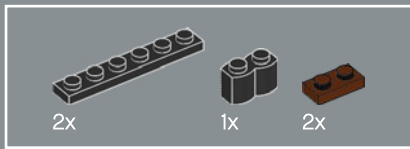

159

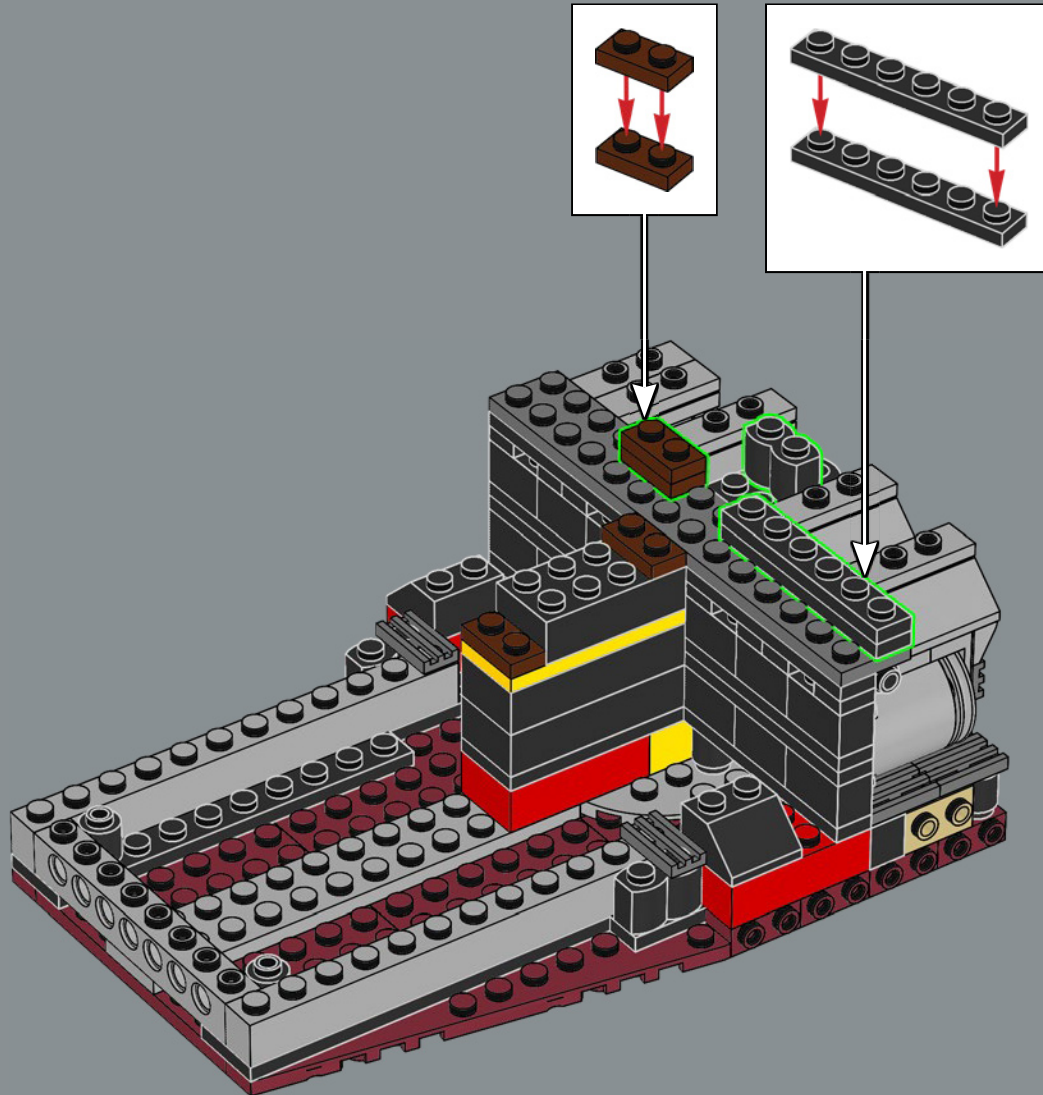

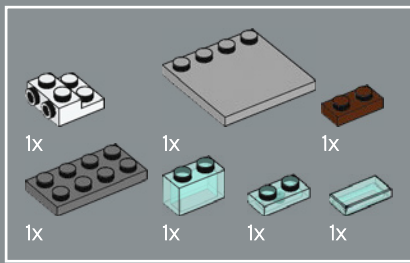

160

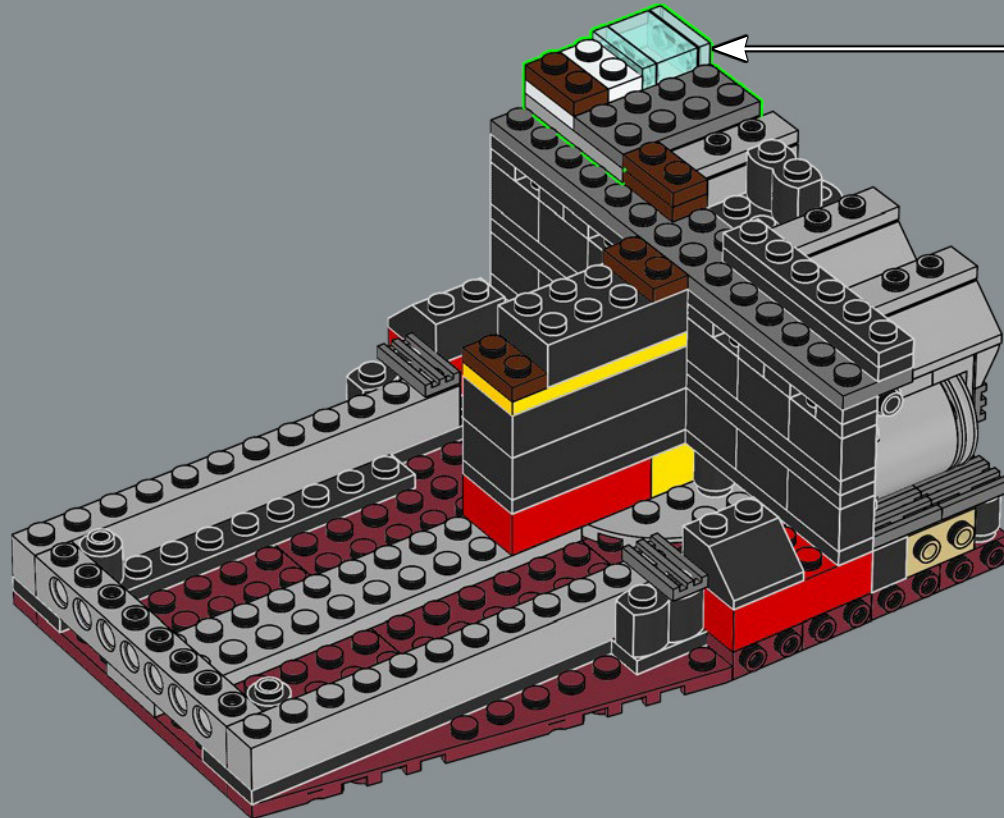
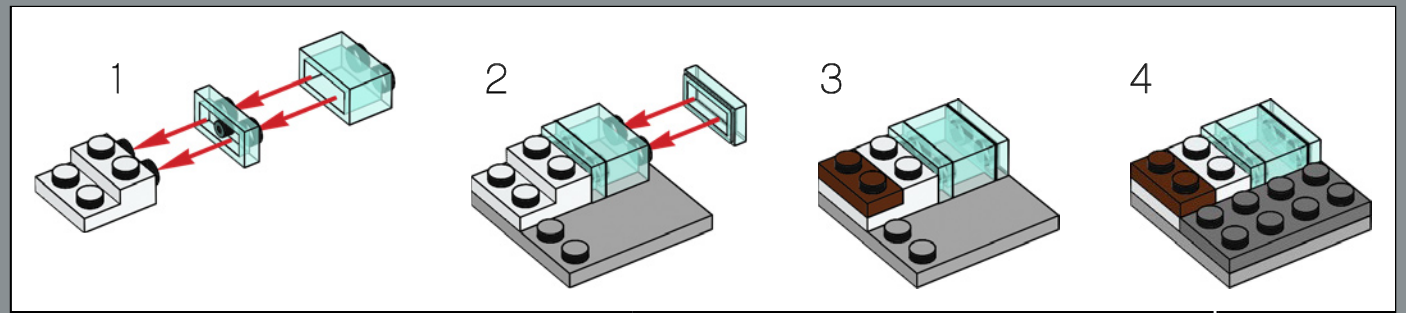

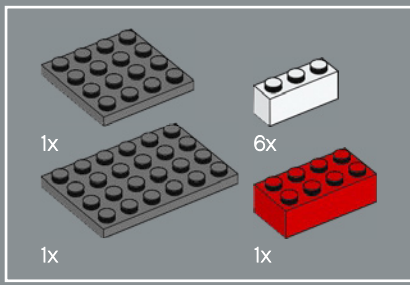

161

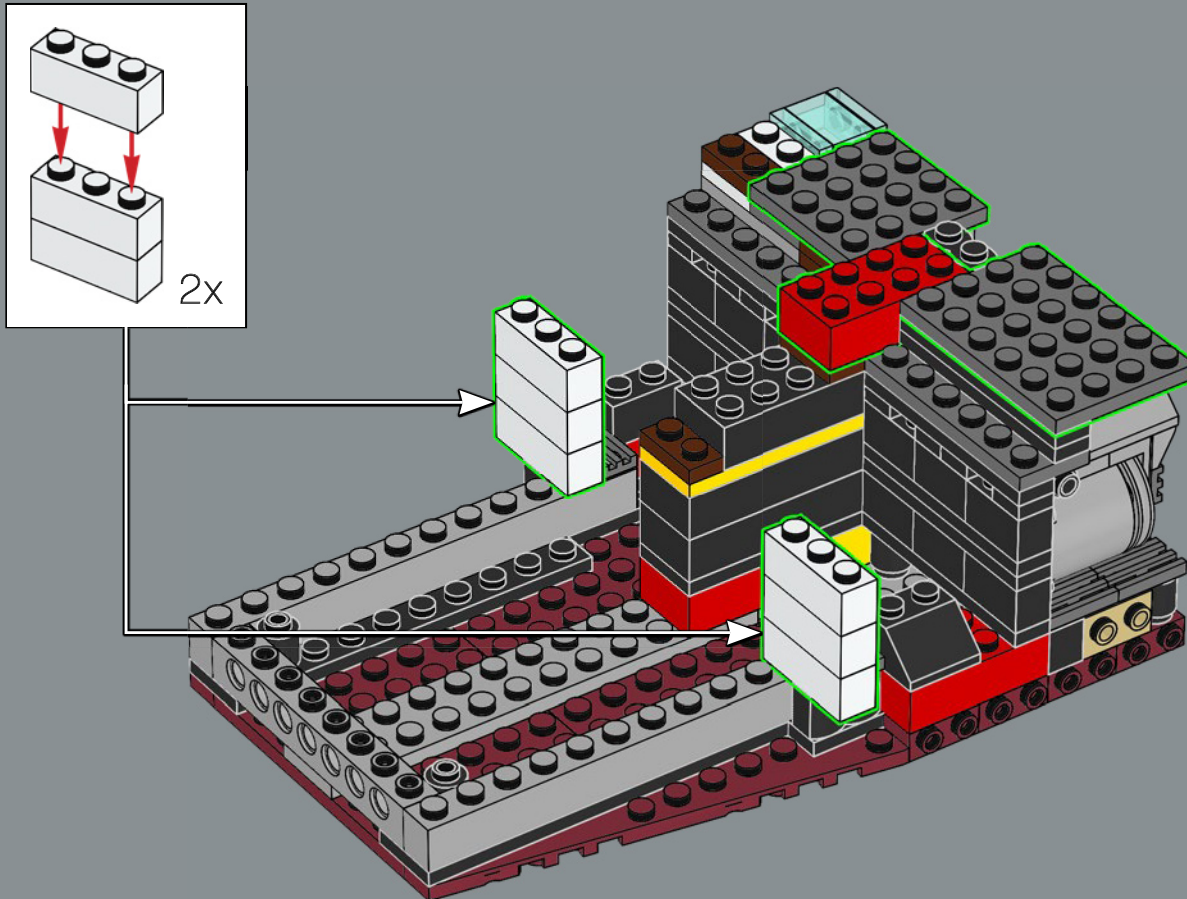

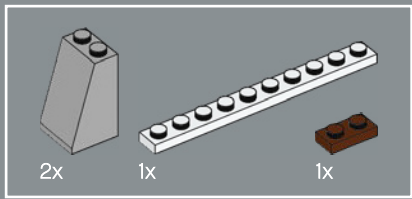

162

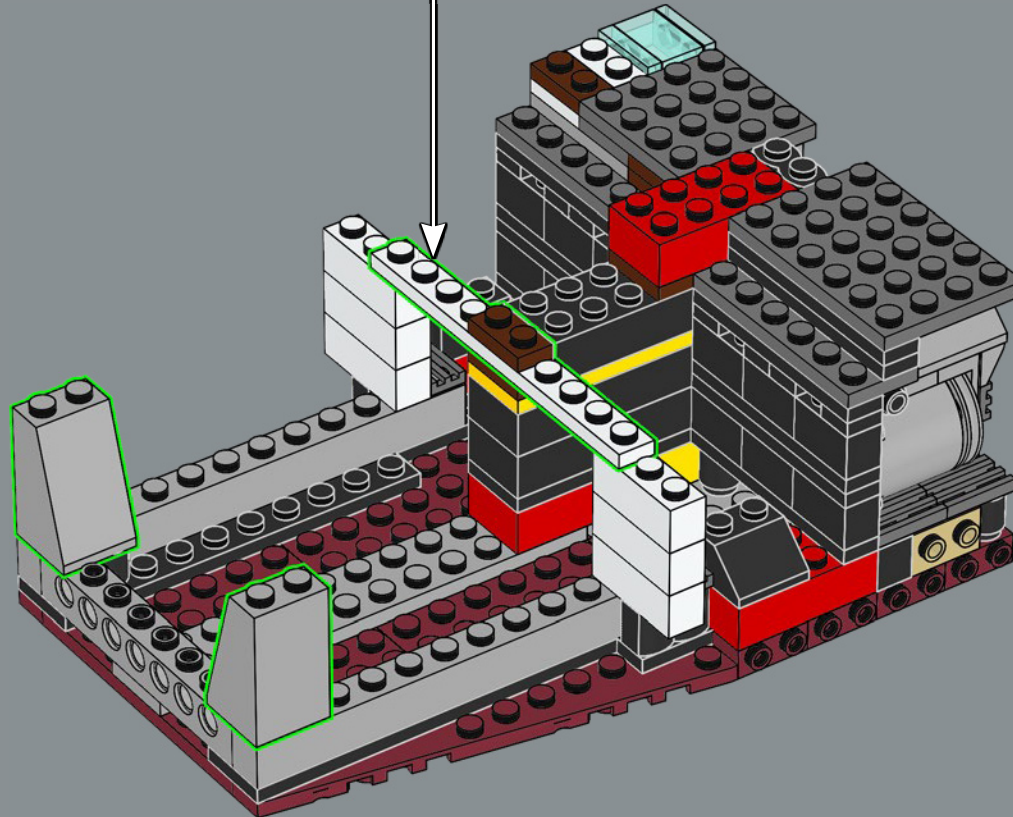
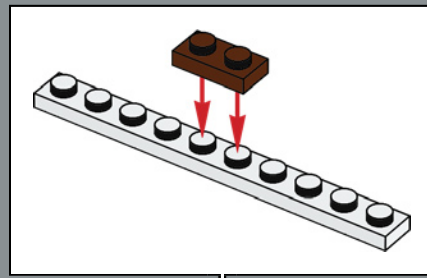



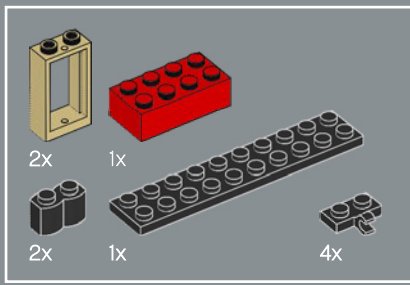

163

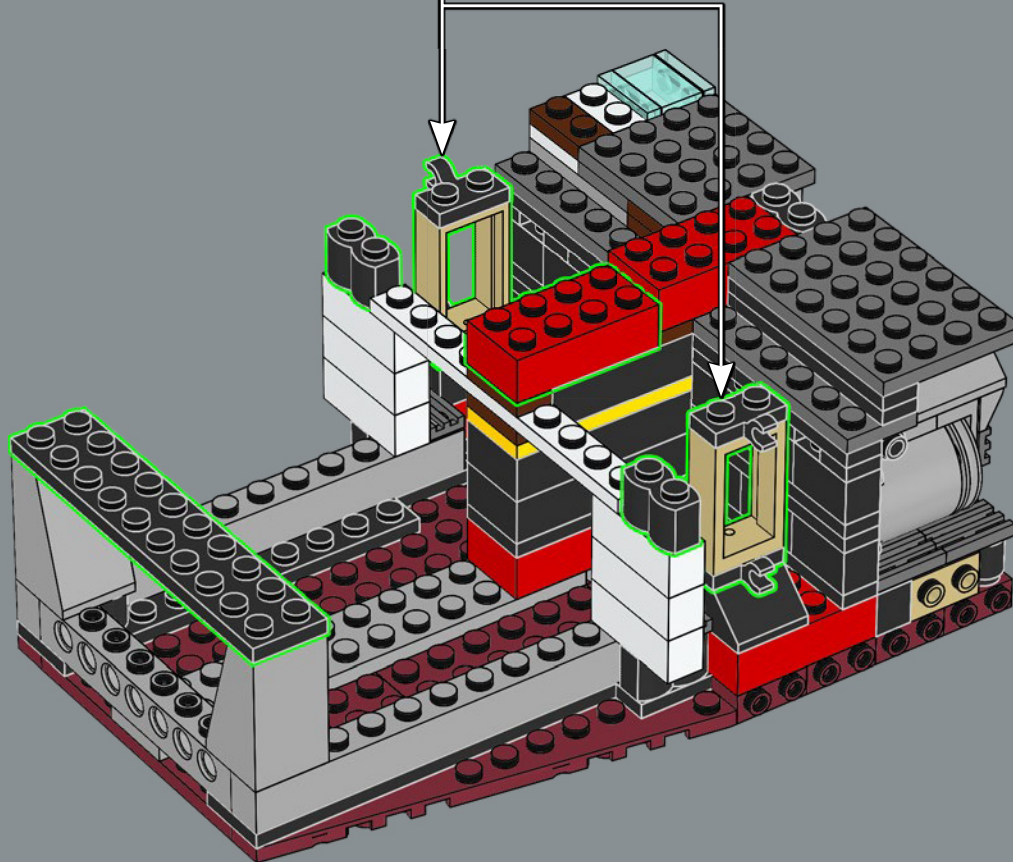
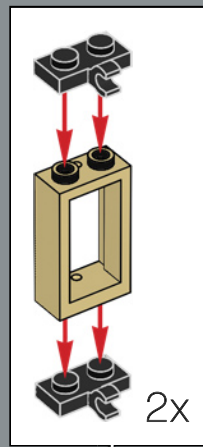

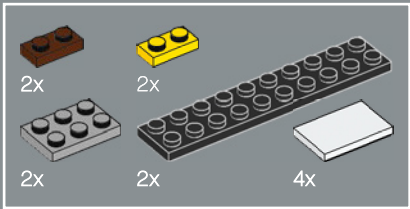

164

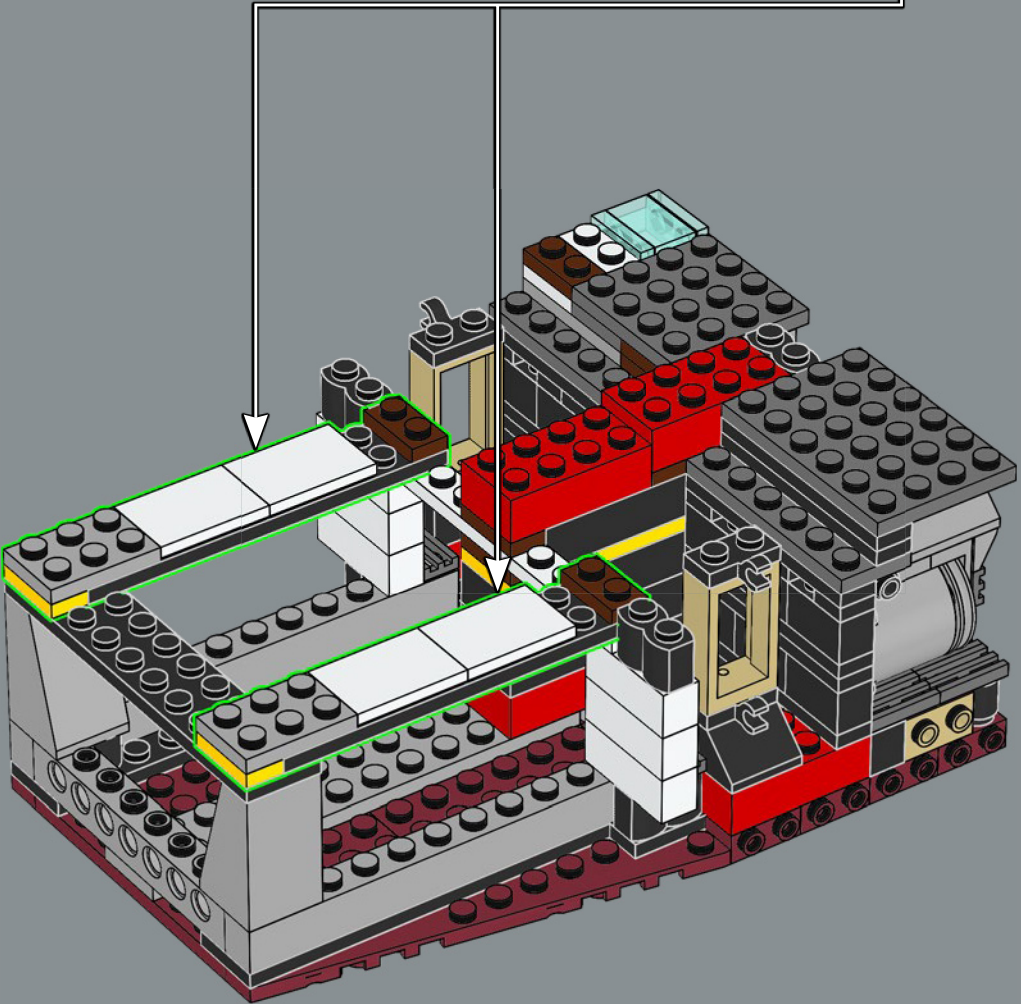
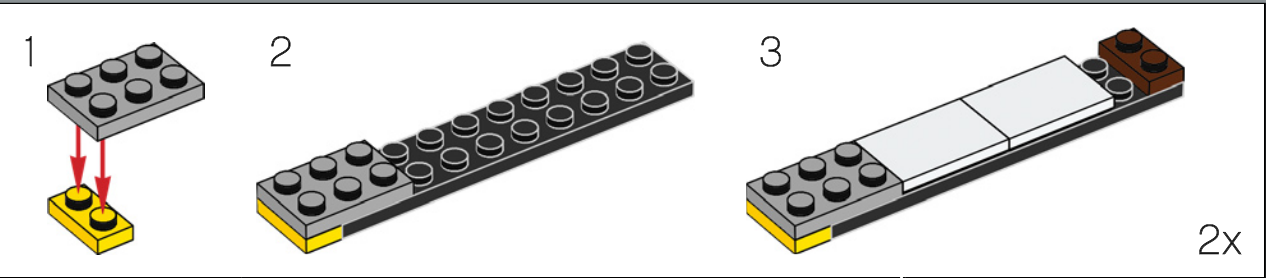

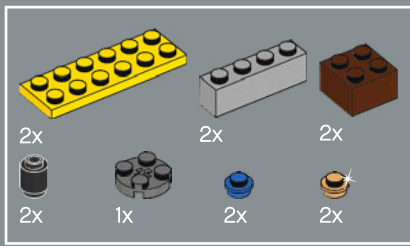

165

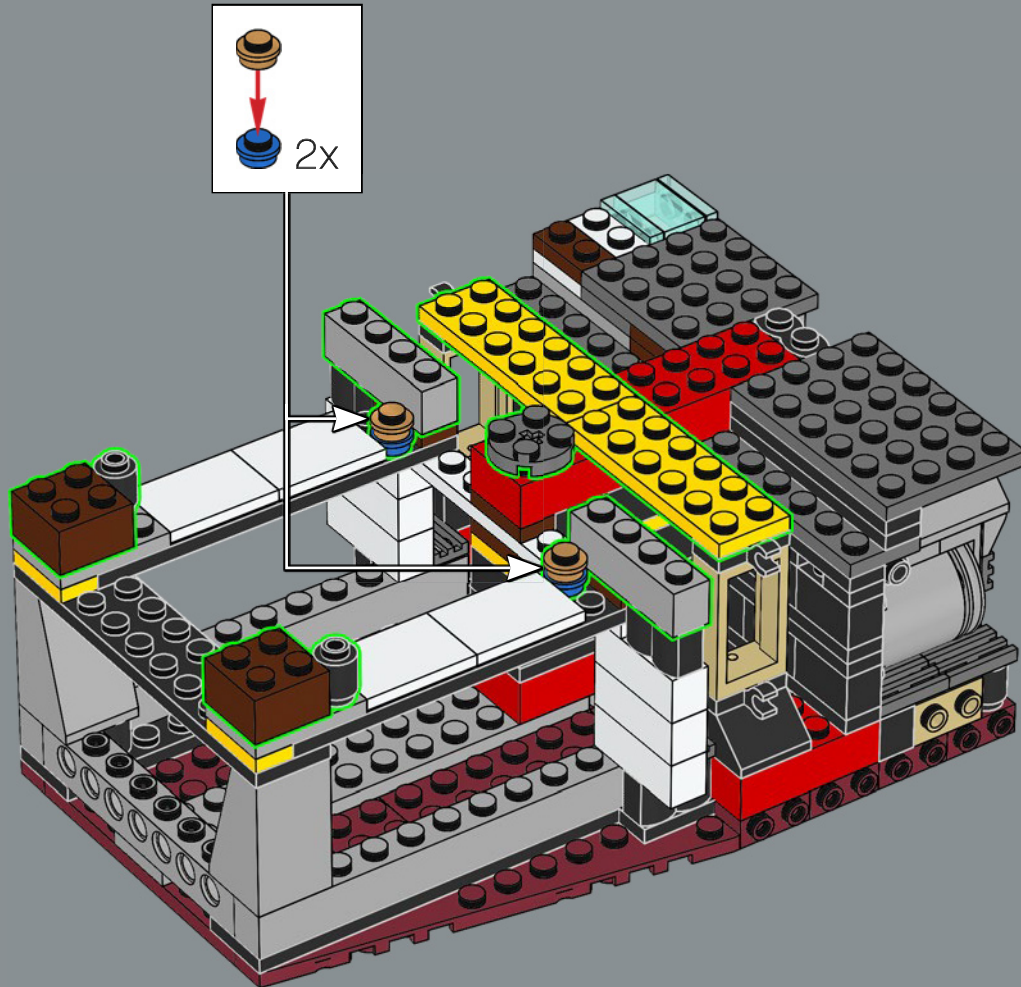

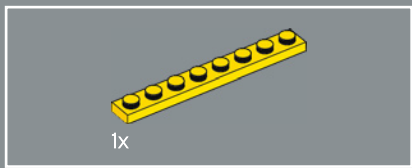

166

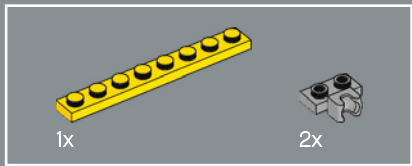
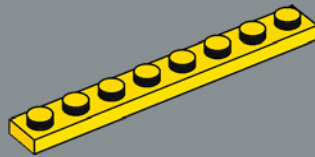

167

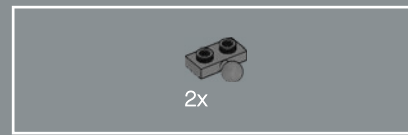
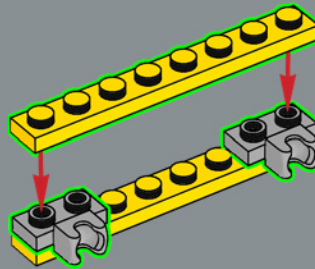

168

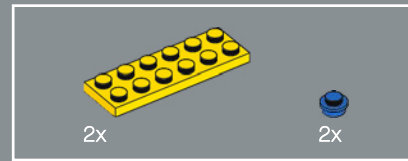
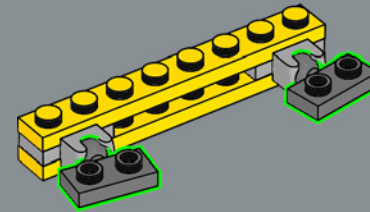

169

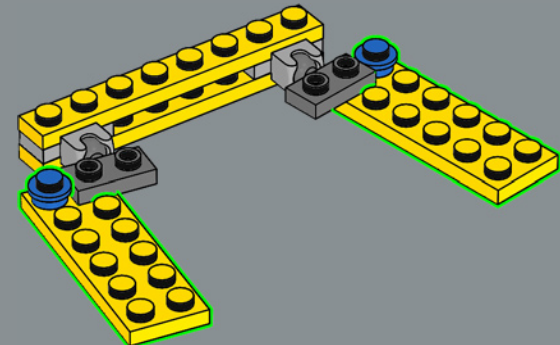

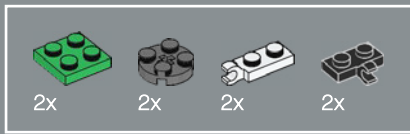

170

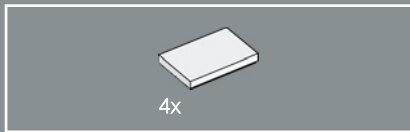
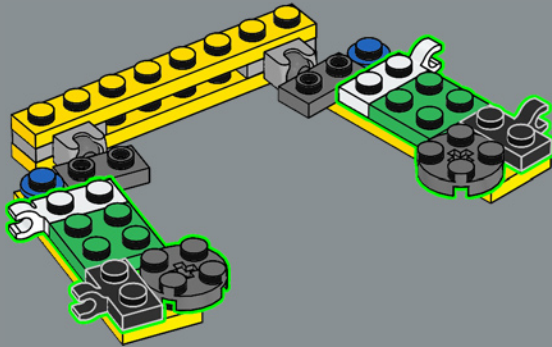

171

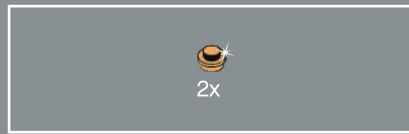
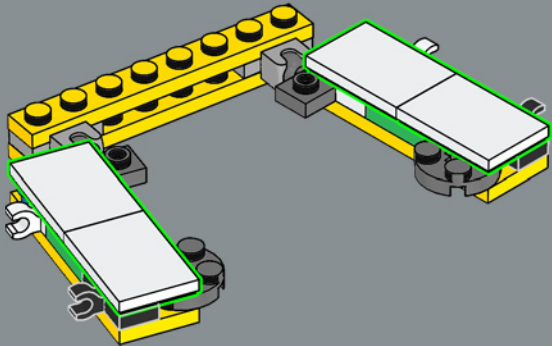

172

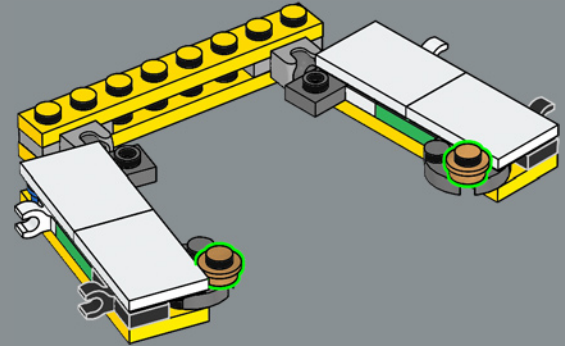

173

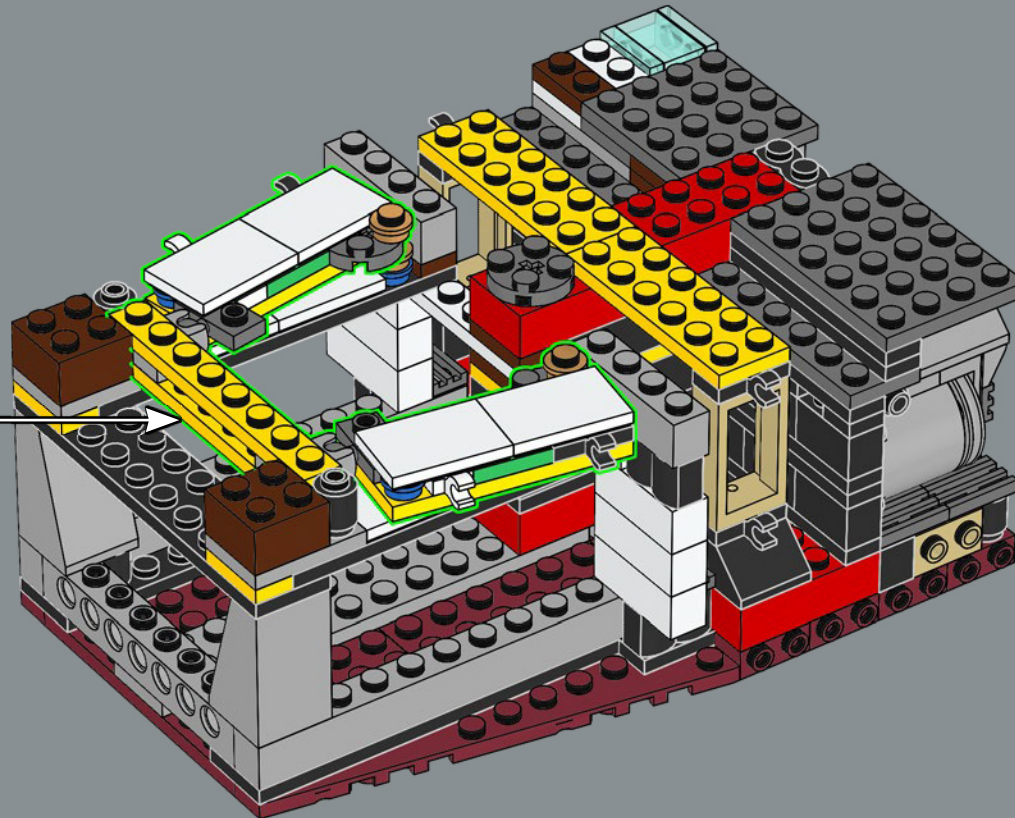

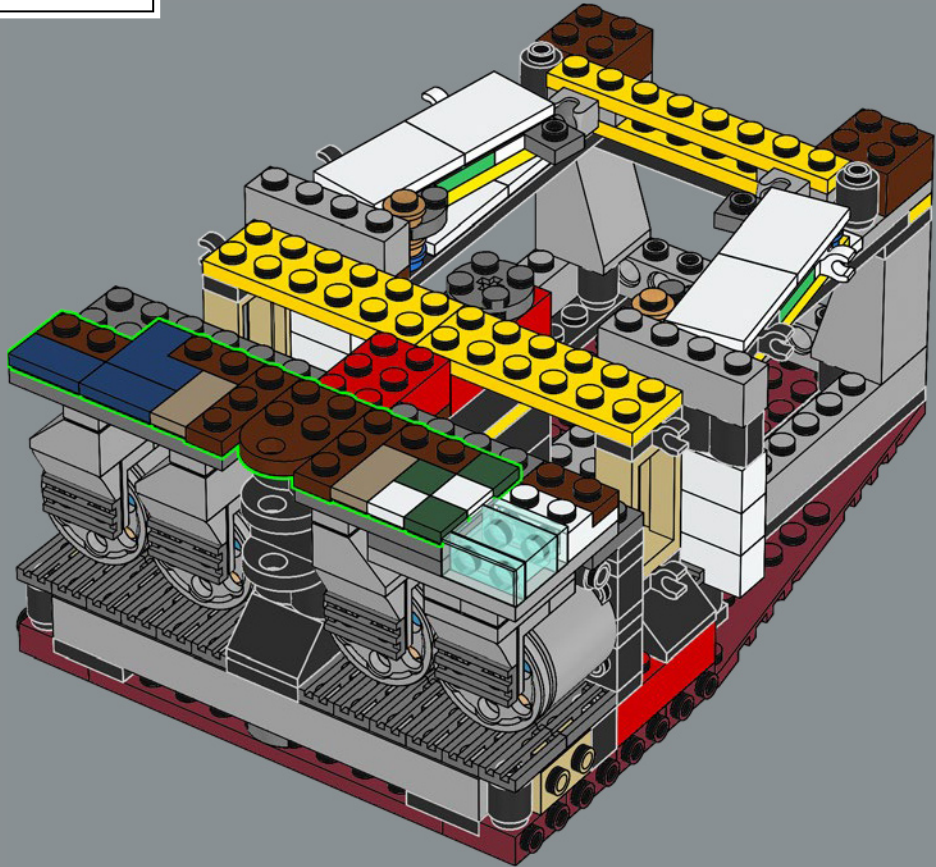
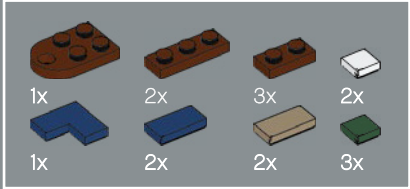
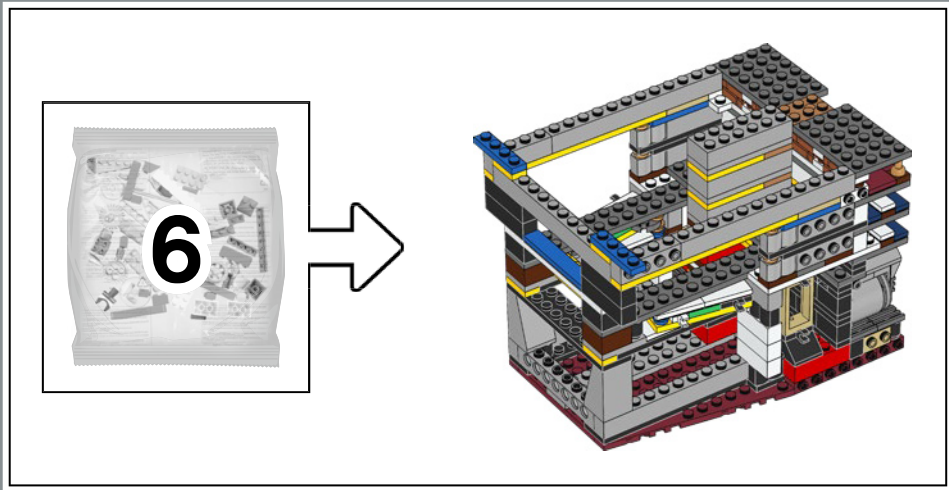

174

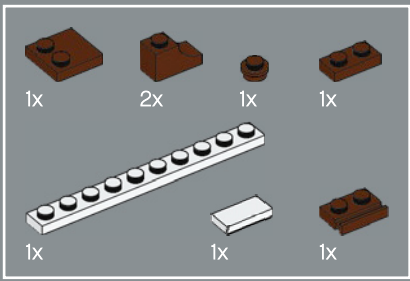

175

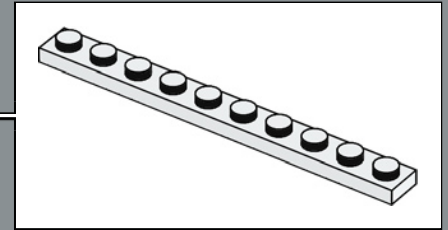
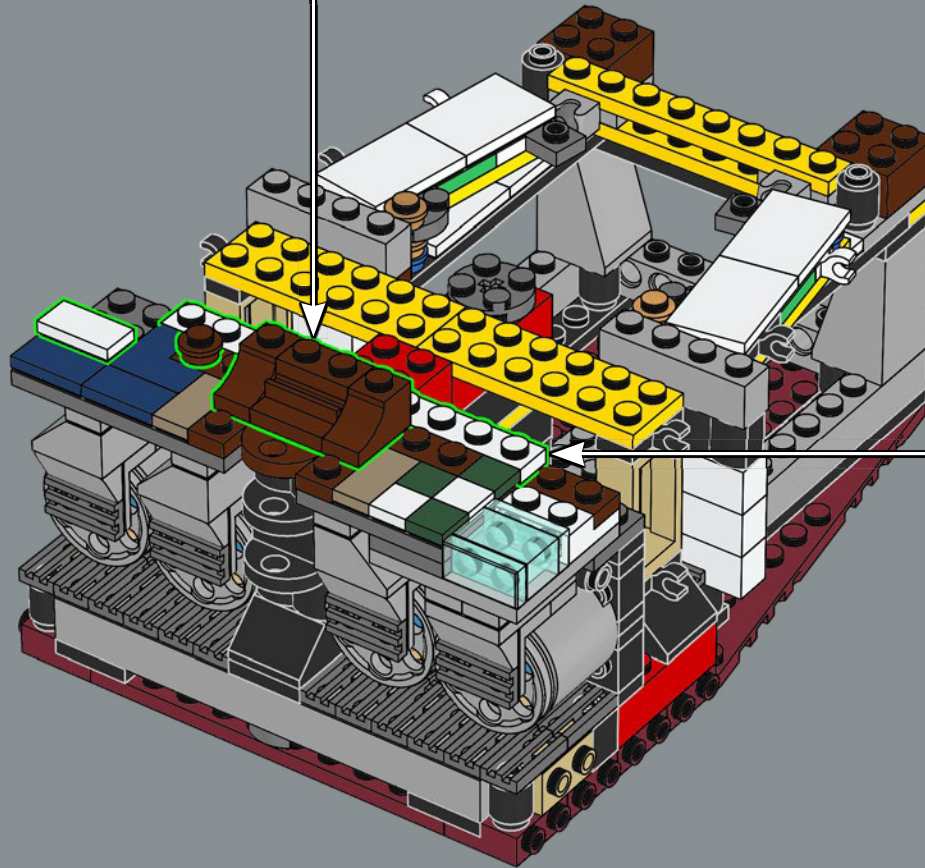
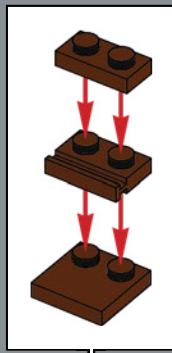





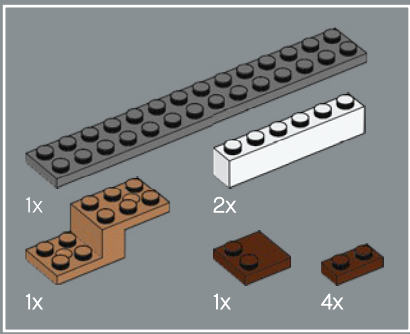

177

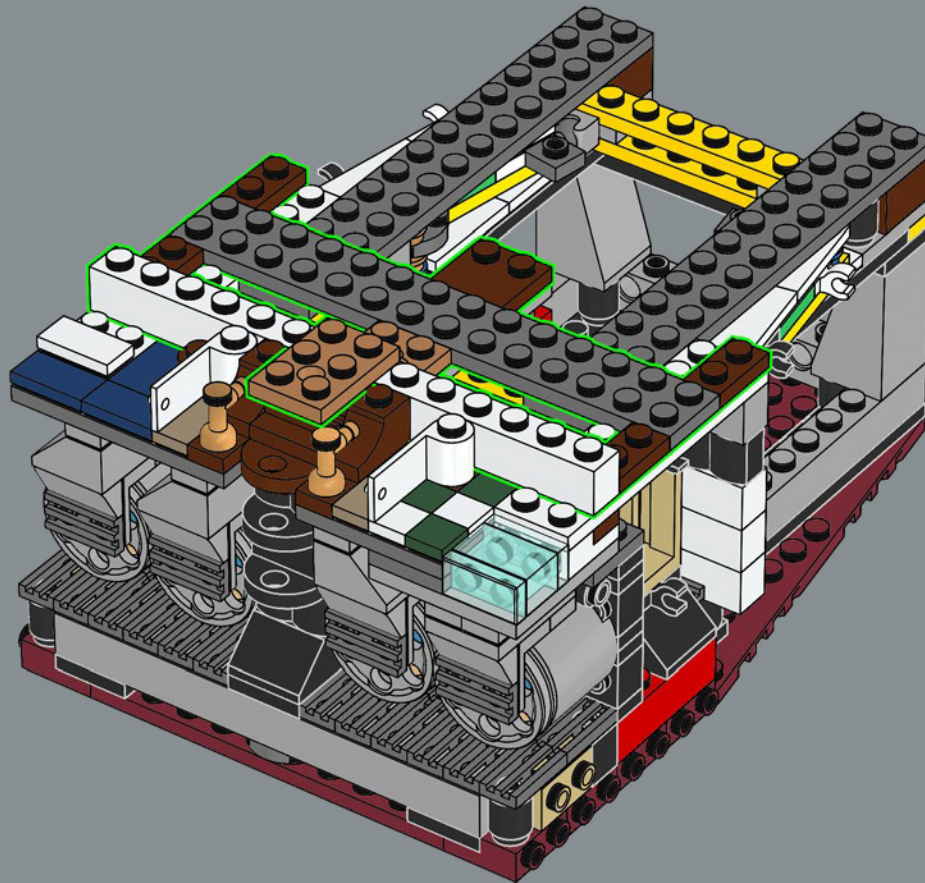

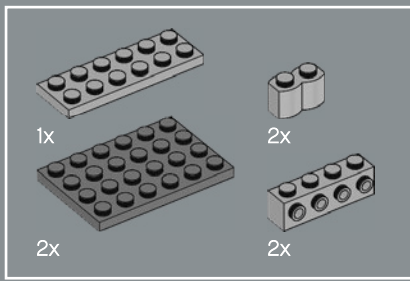

178

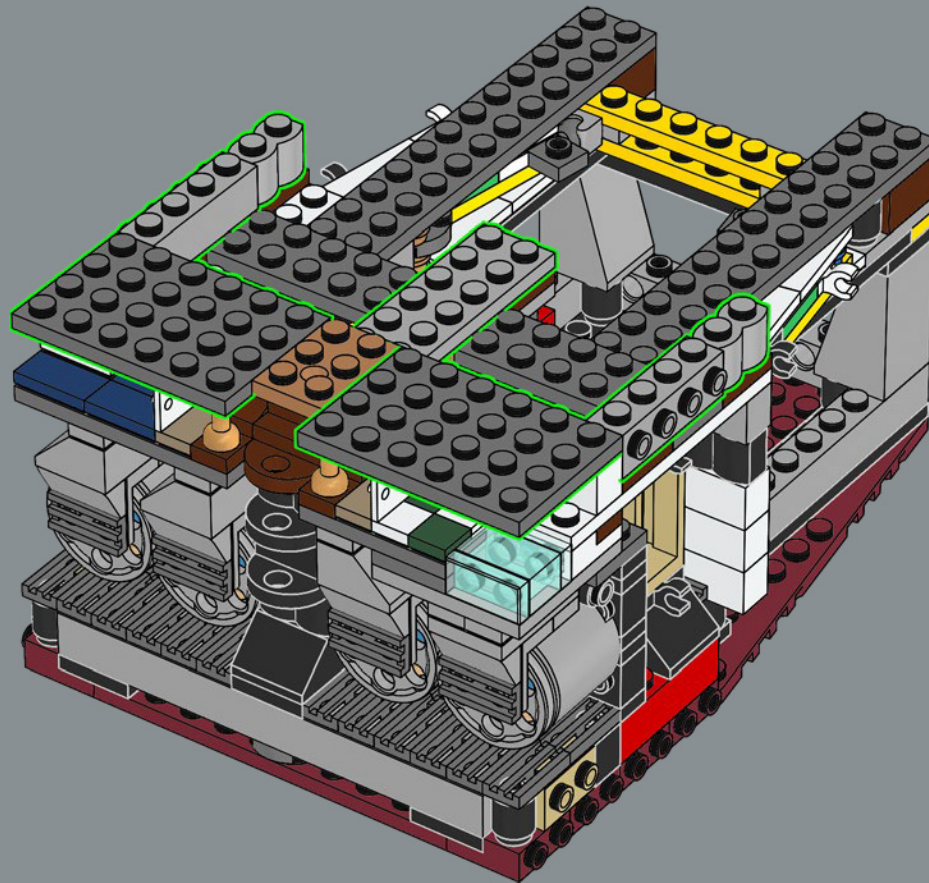

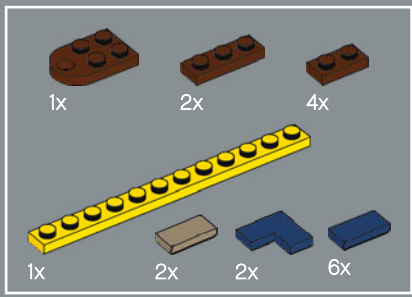

179

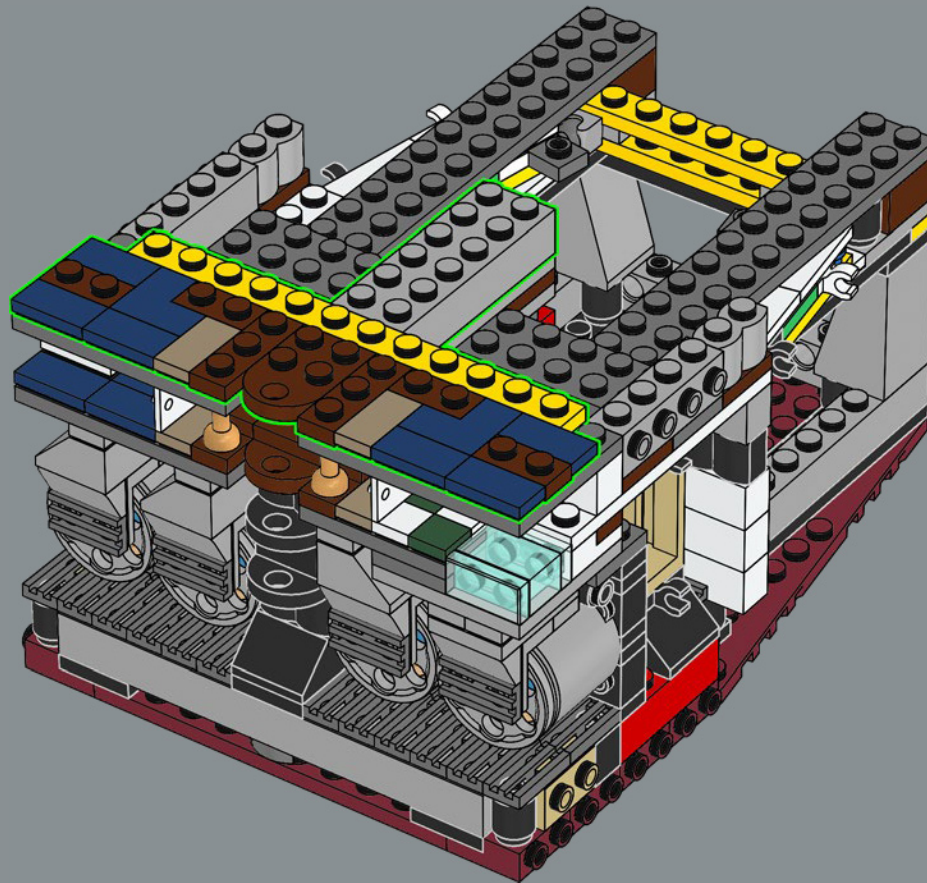



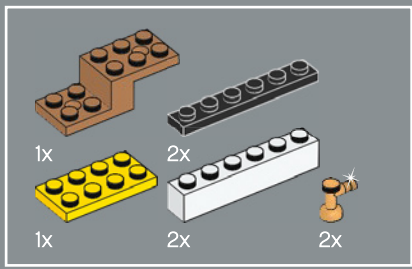

181

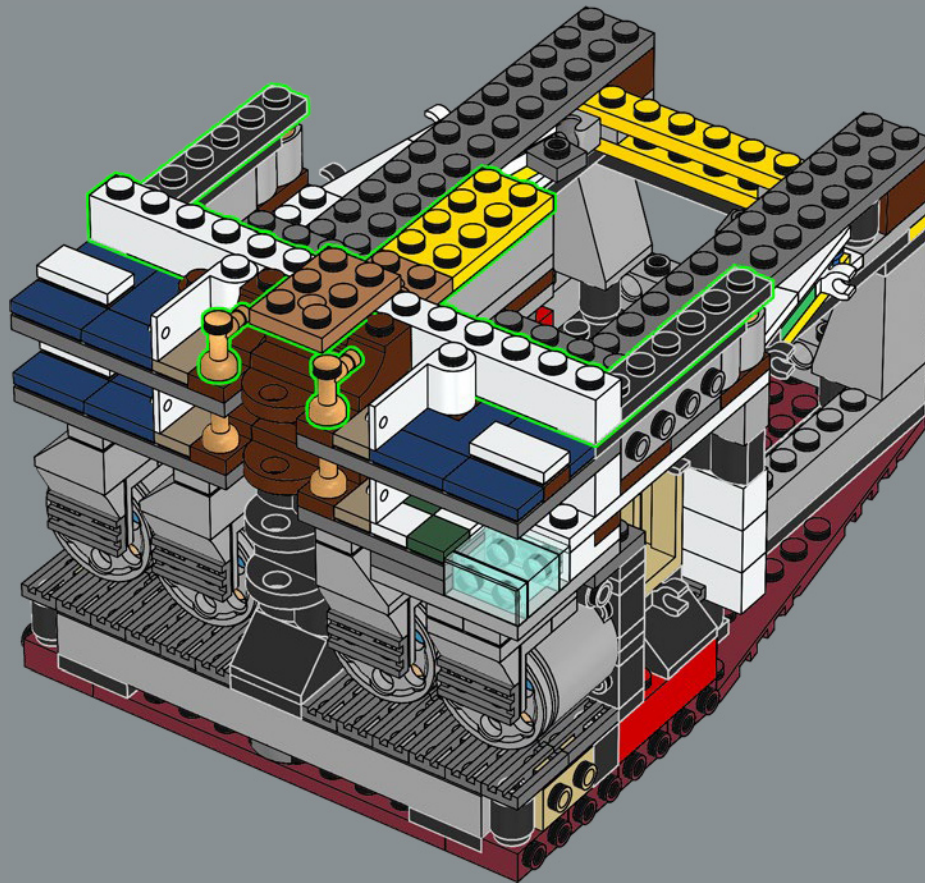

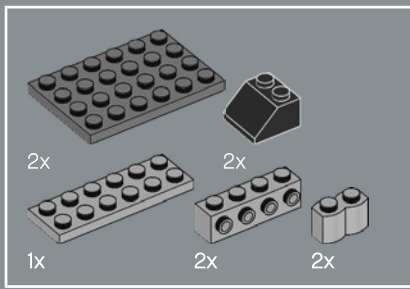

182

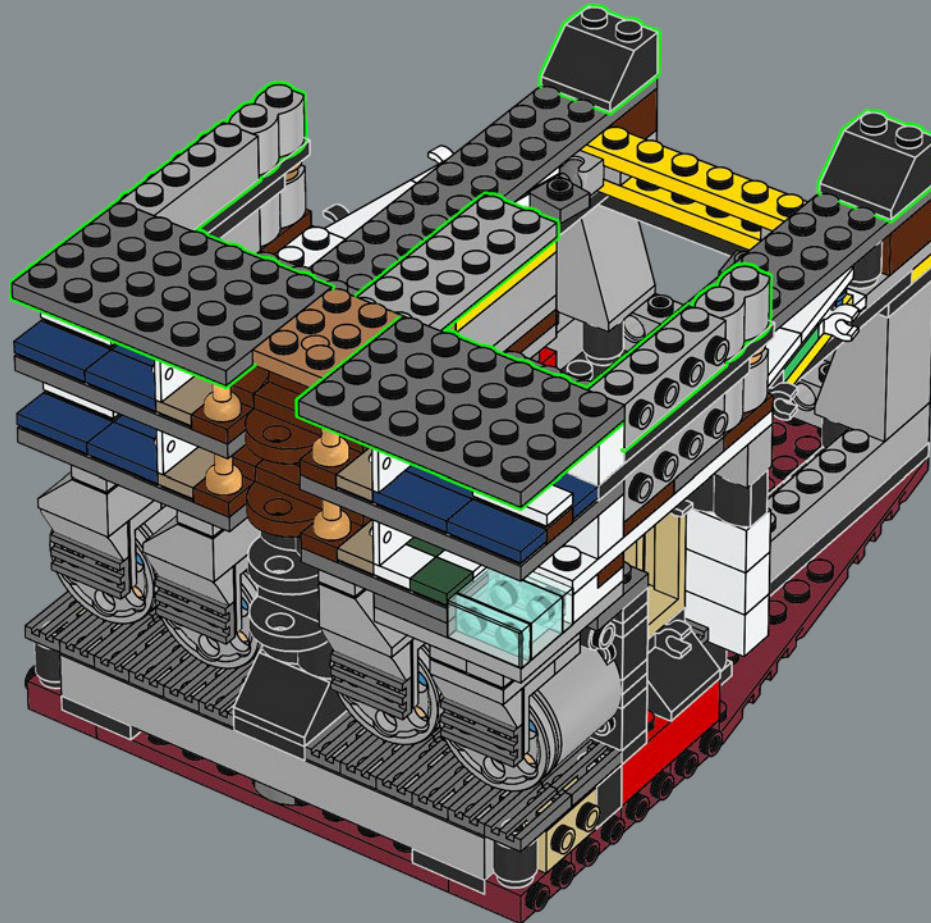

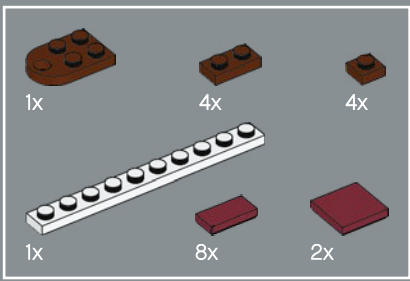

183

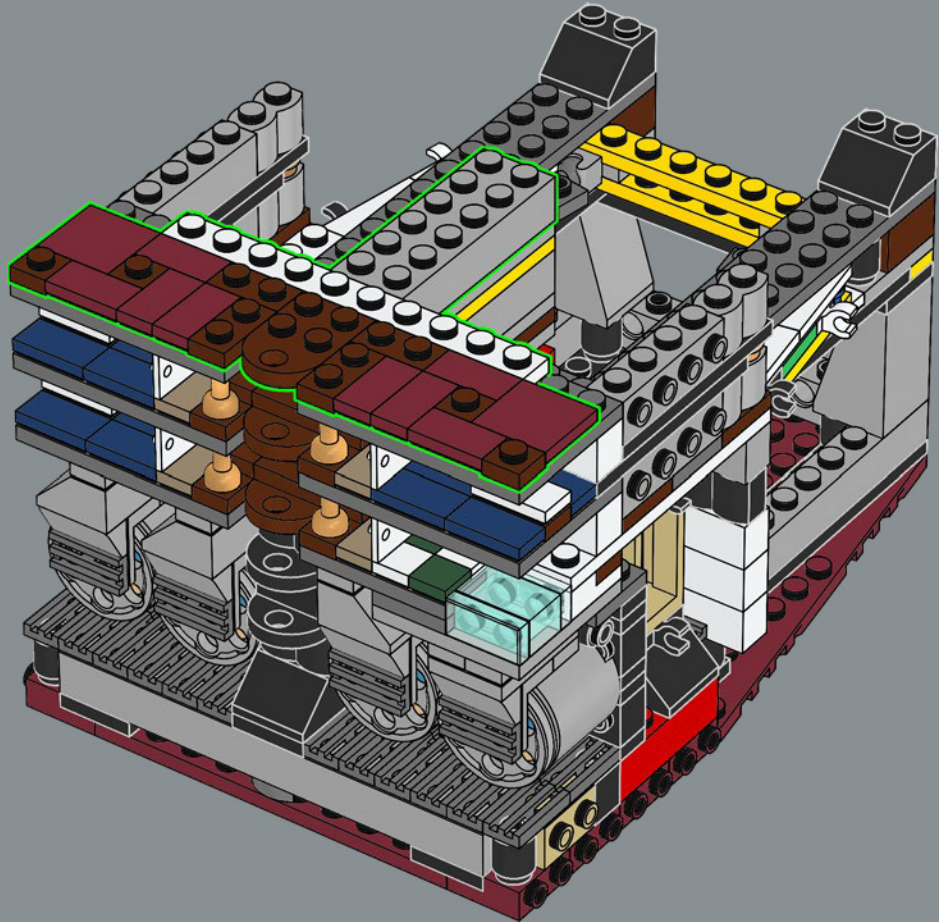



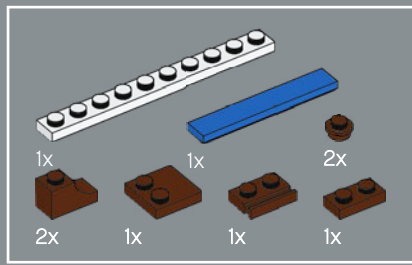

184

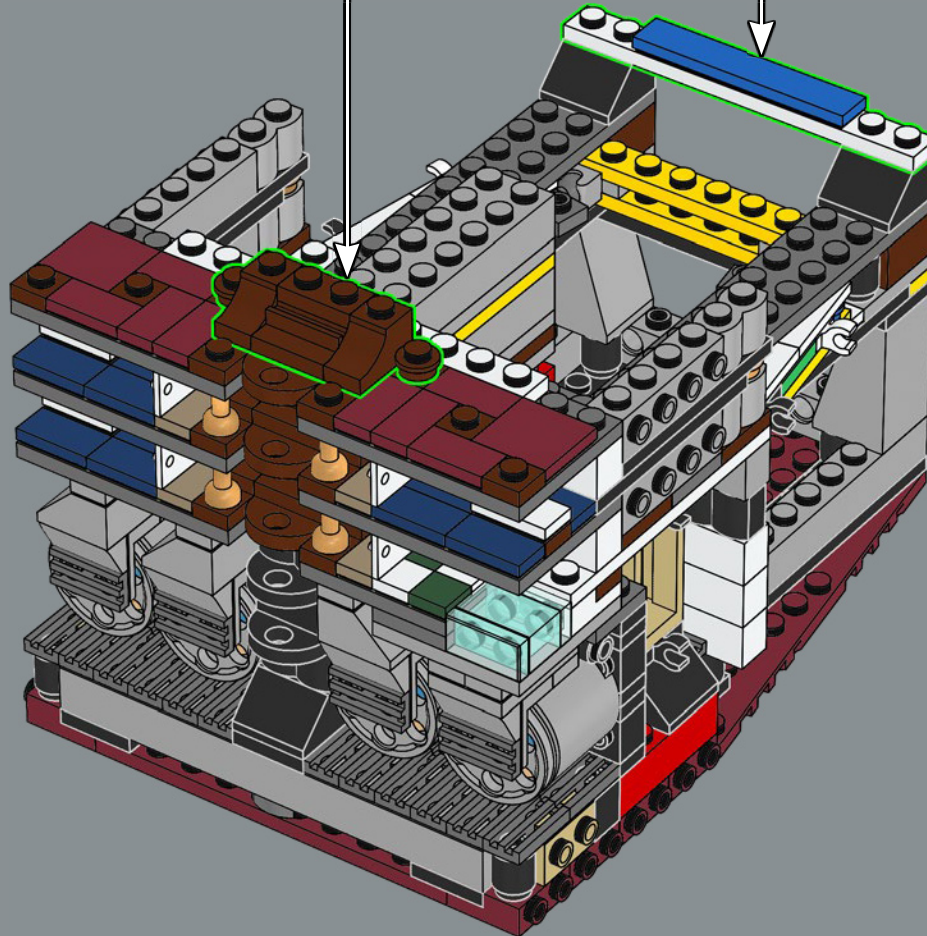
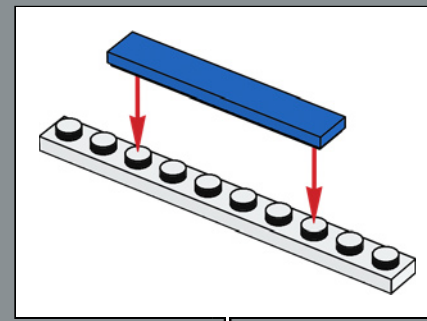
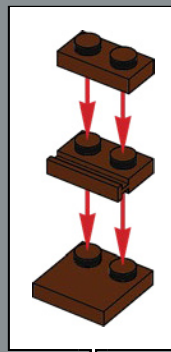

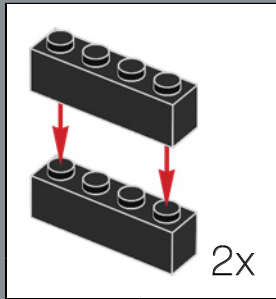
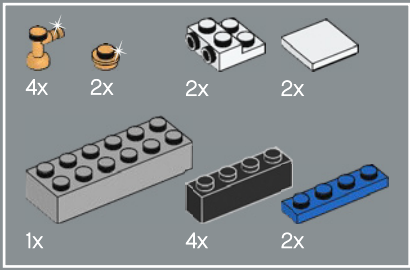

185

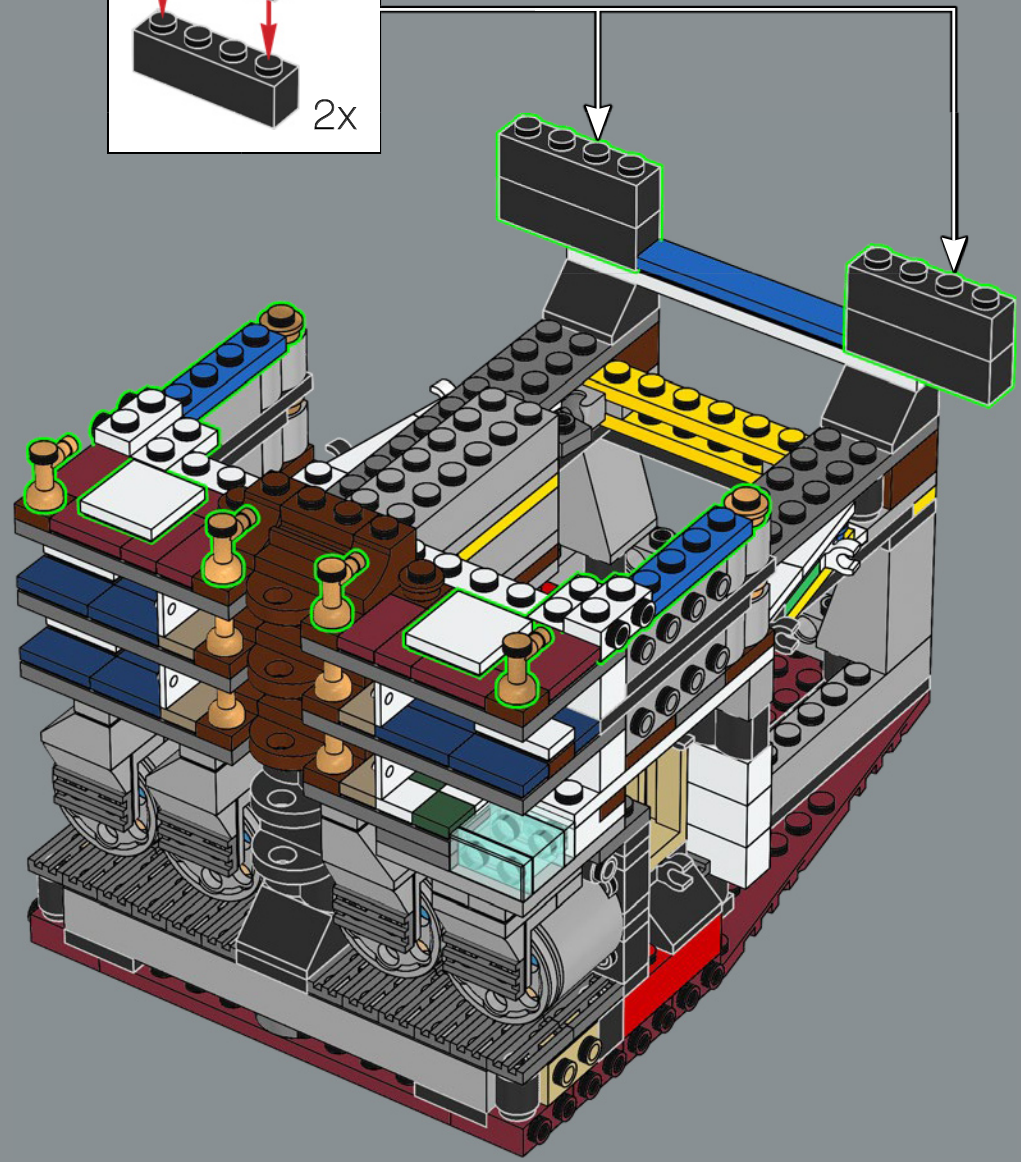

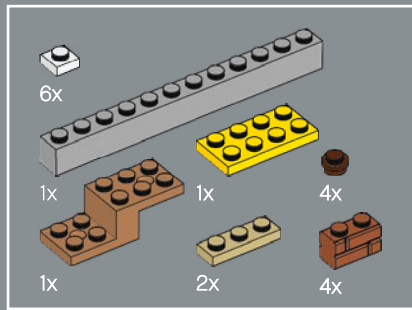

186

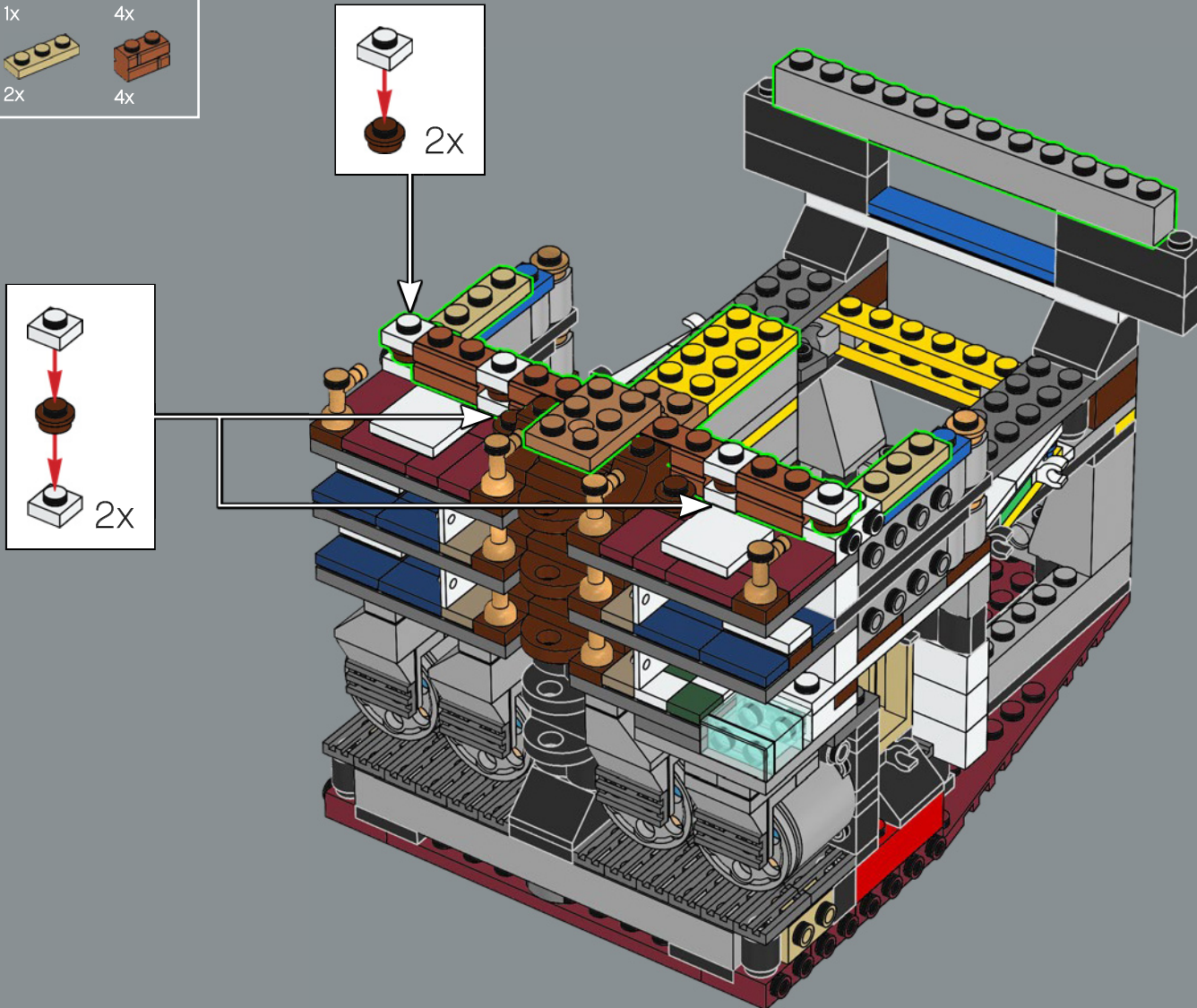

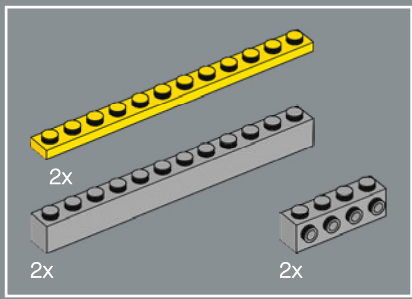

187

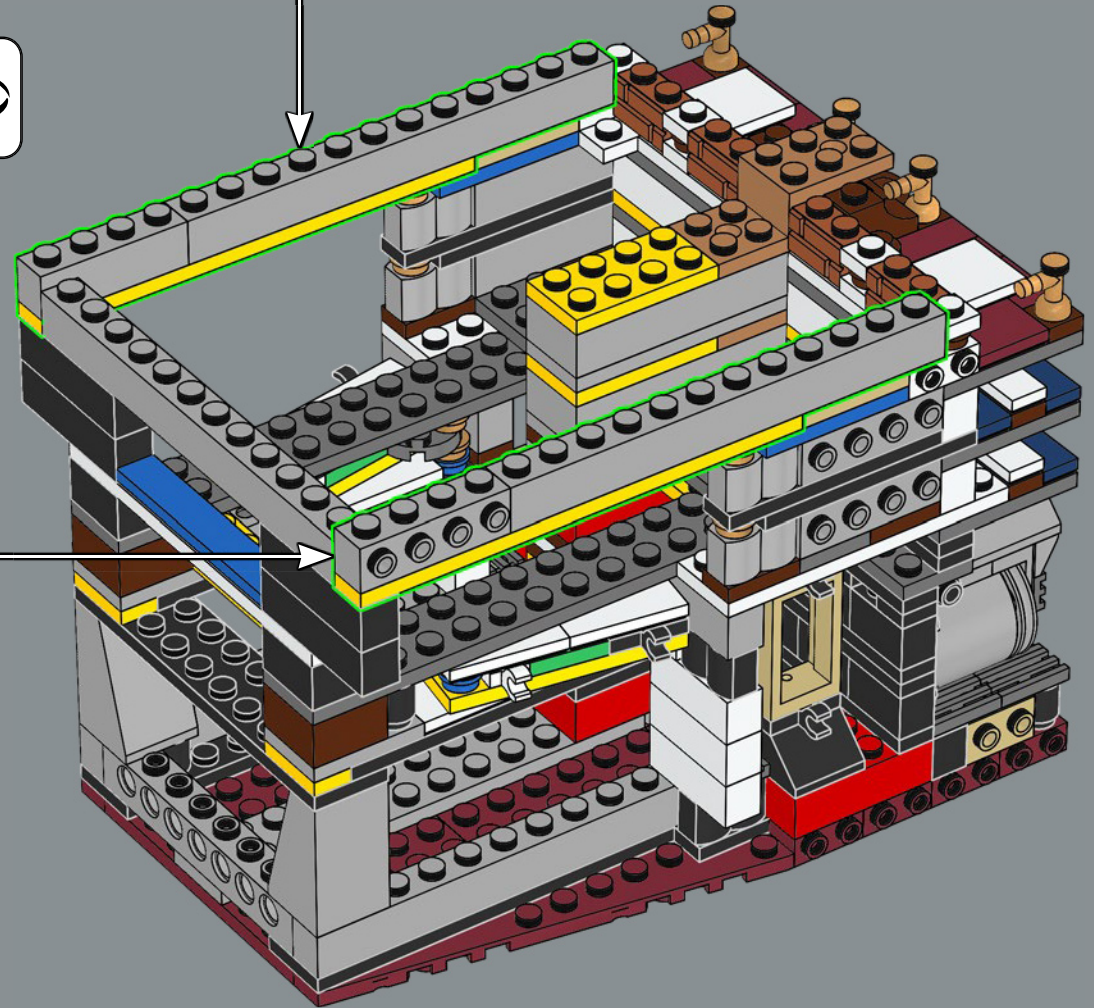
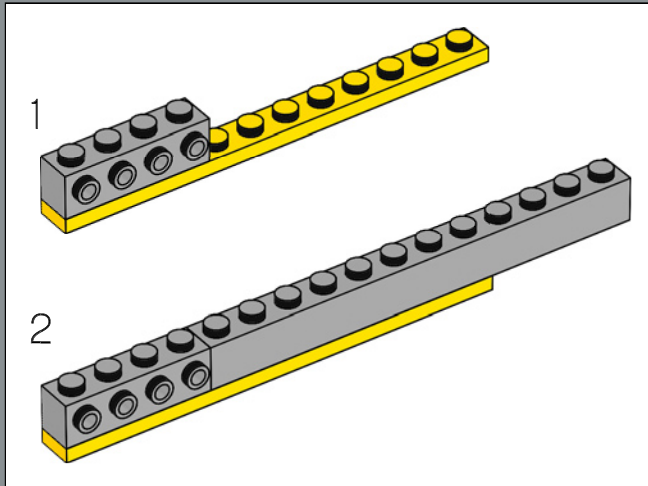
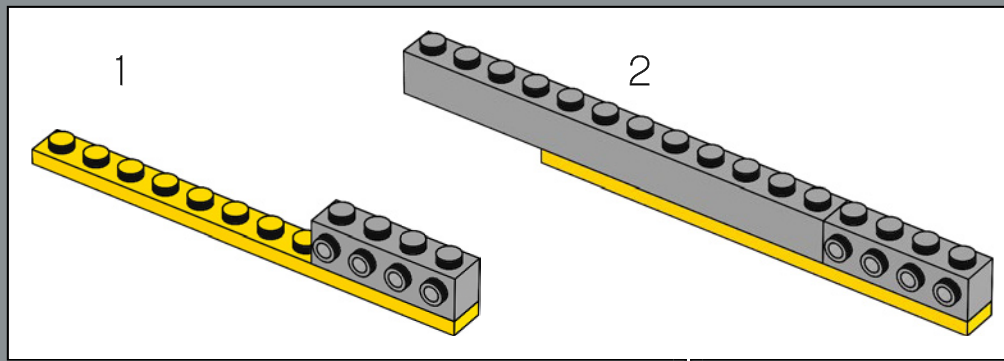



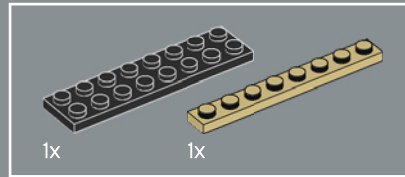
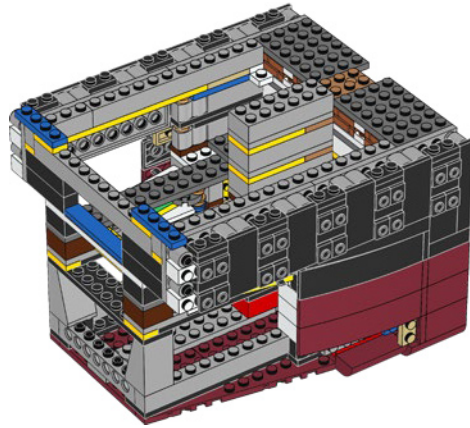
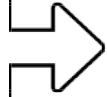

190

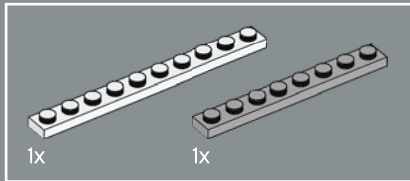
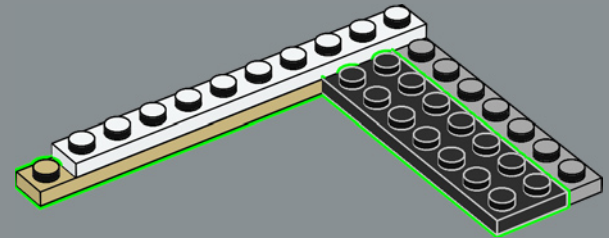

189

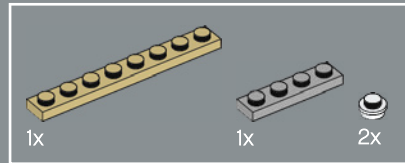
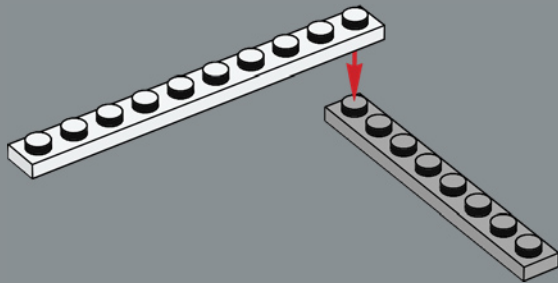

191

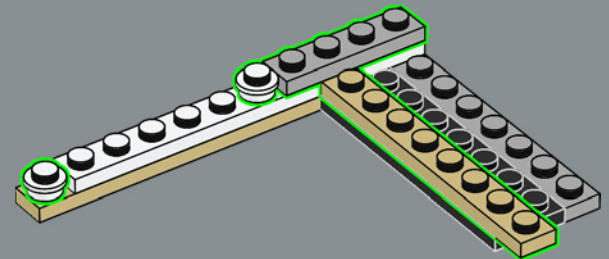

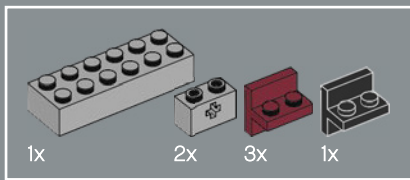

192

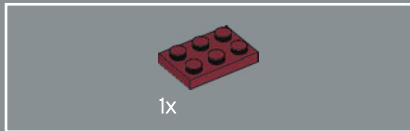
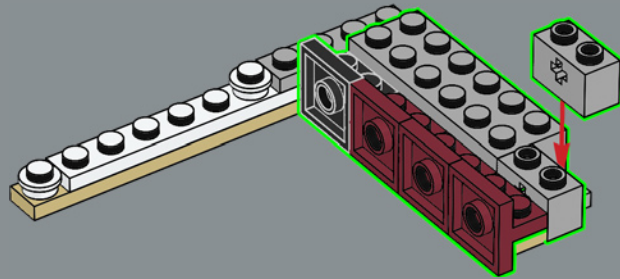

193

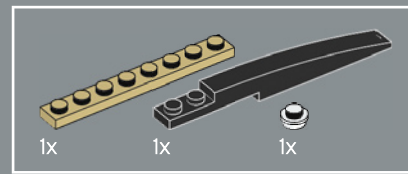
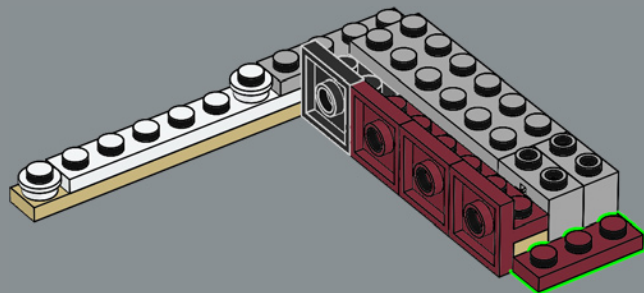

194

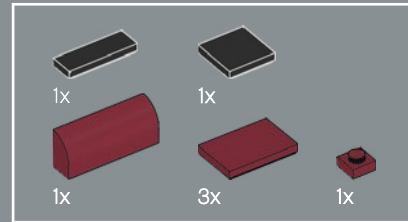
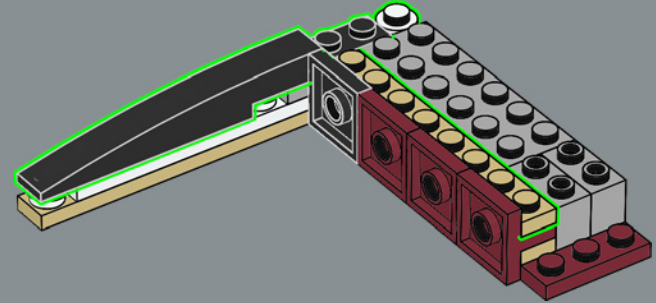

195

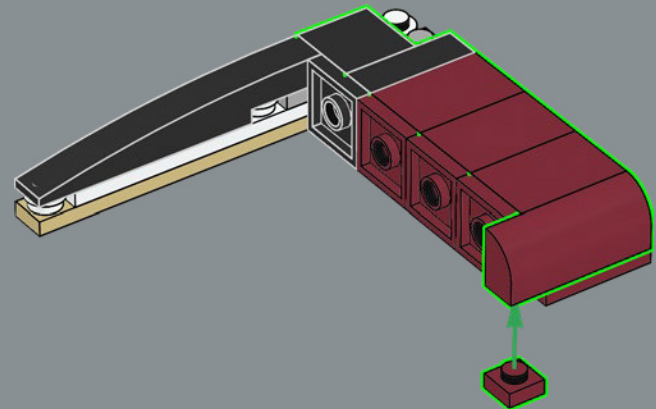

196

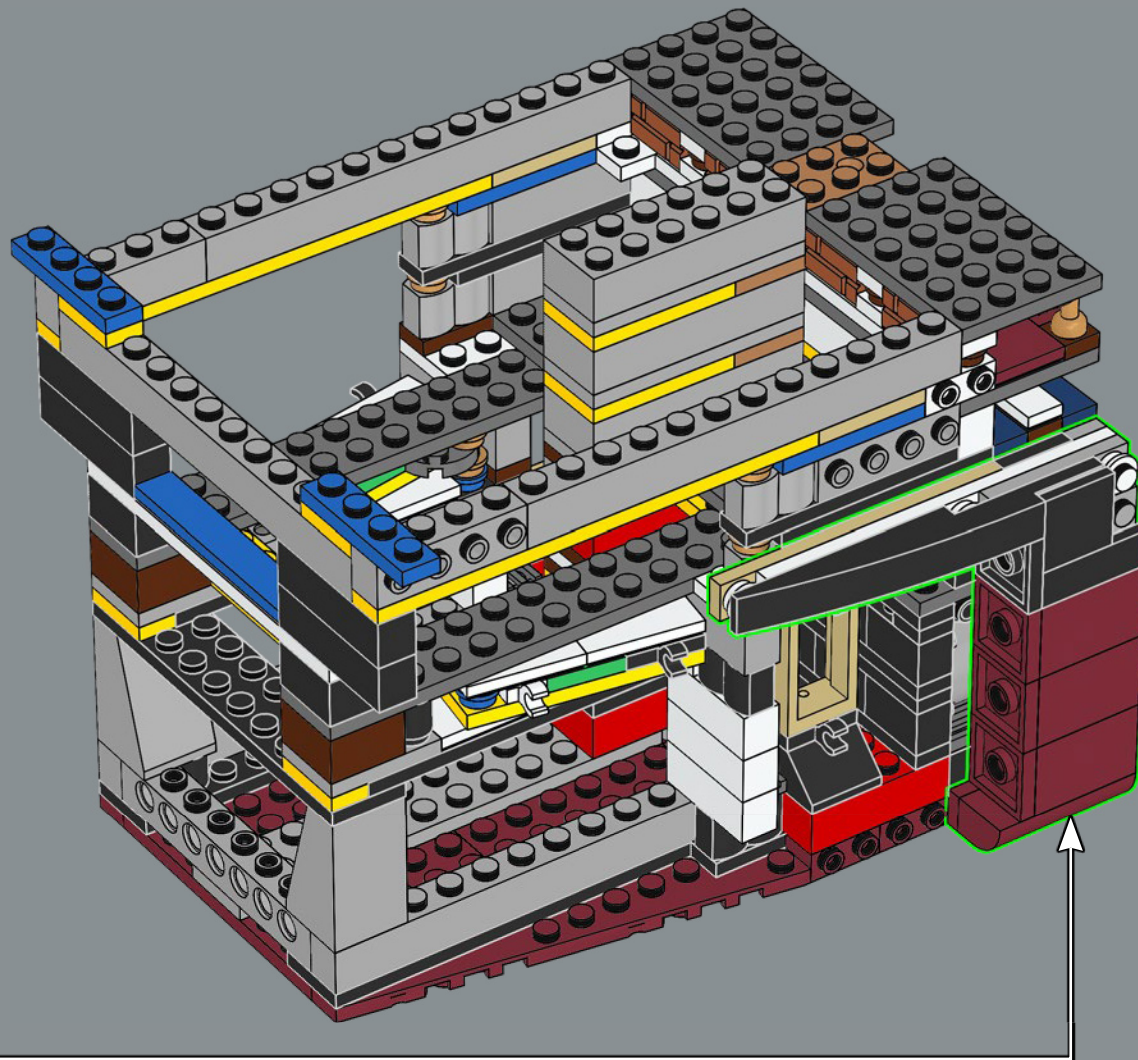



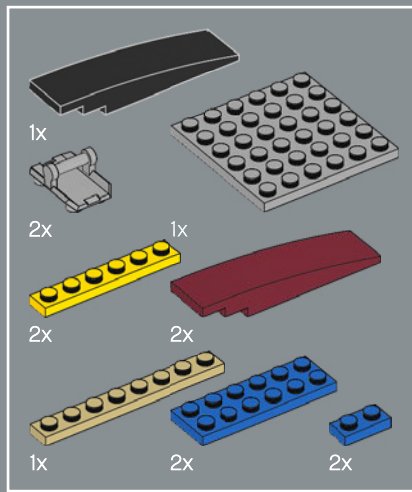

197

1

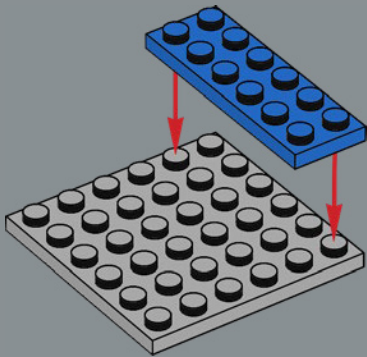

2

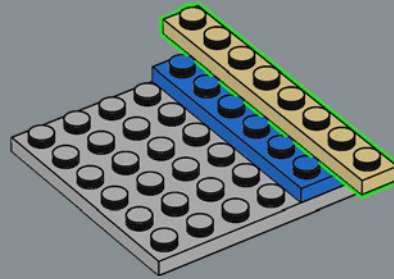

3

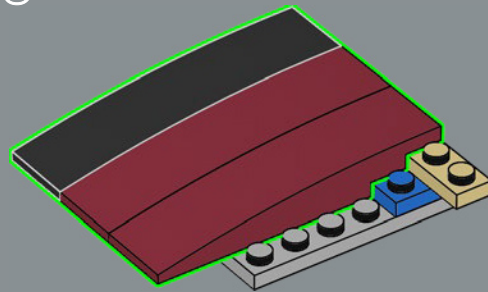

4

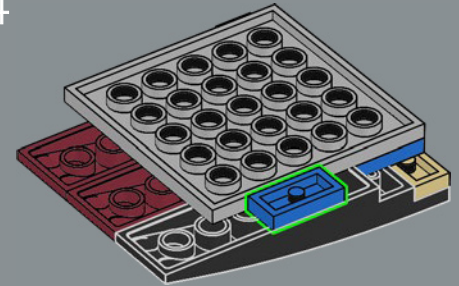

5

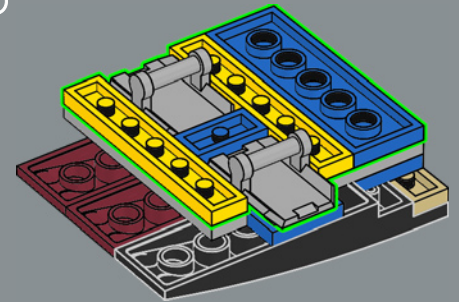

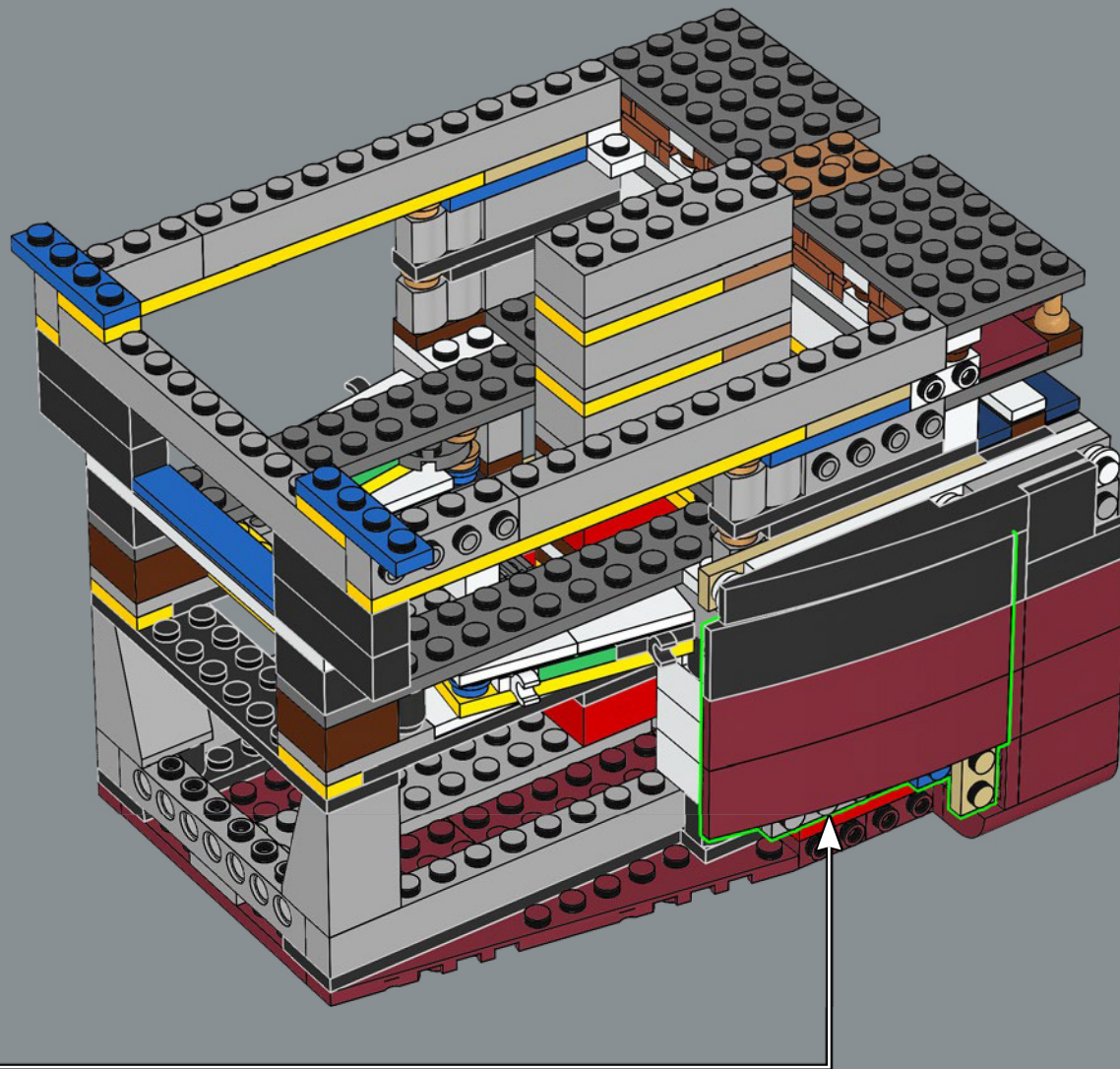

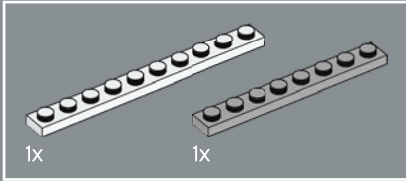
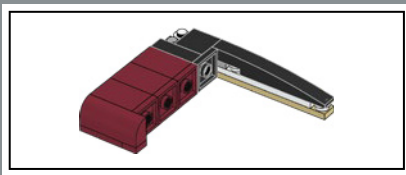

198

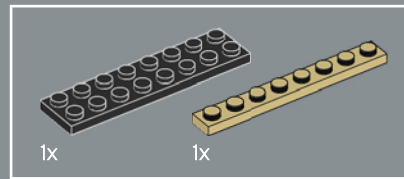
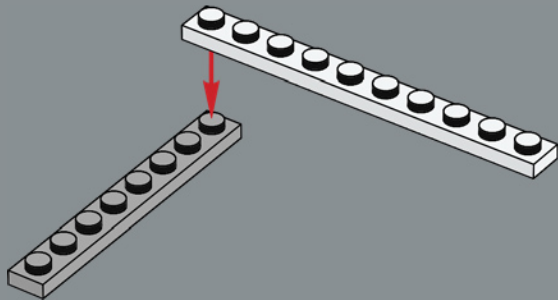

199

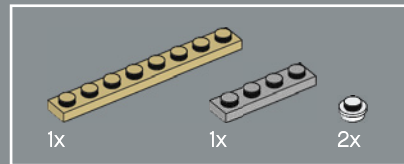
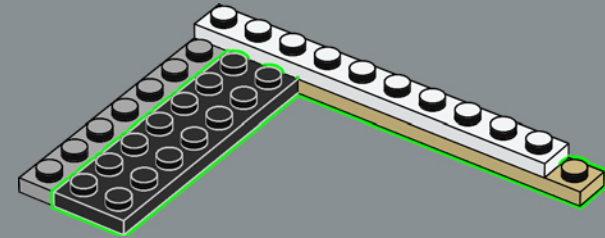

200

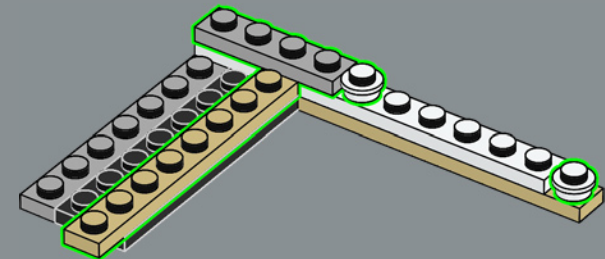

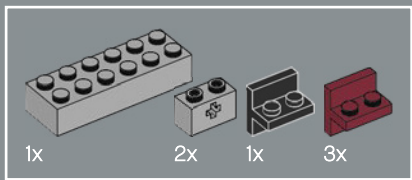

201

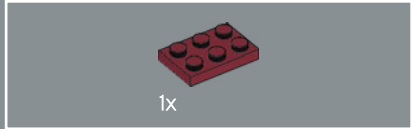
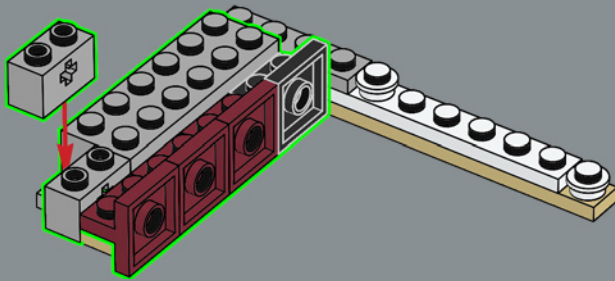

202

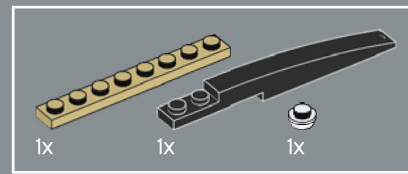
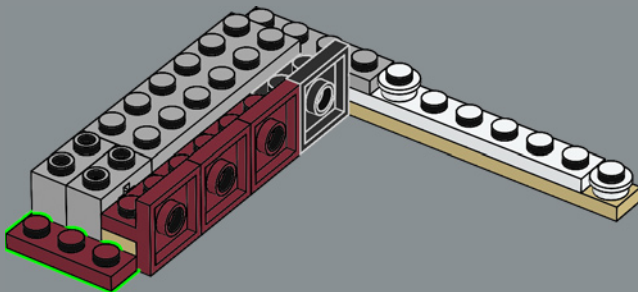

203

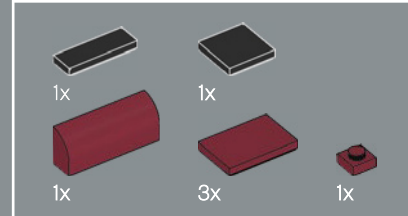
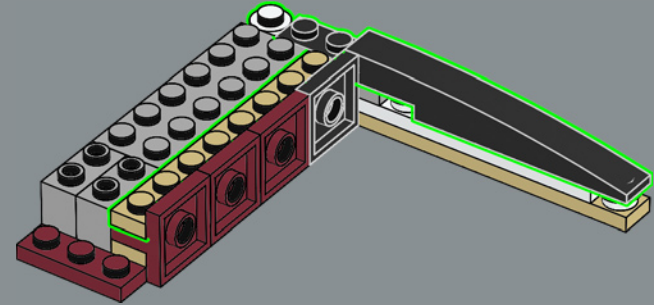

204

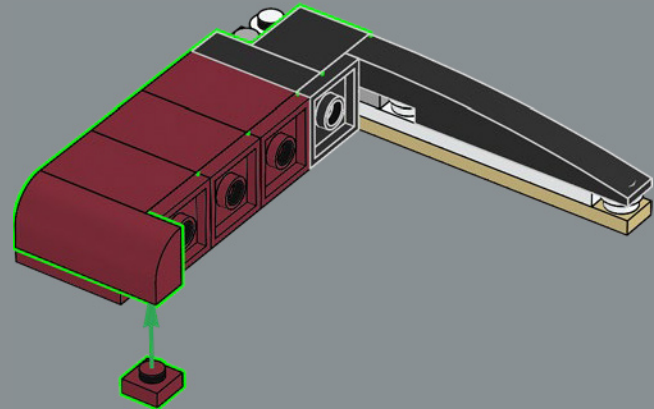

205

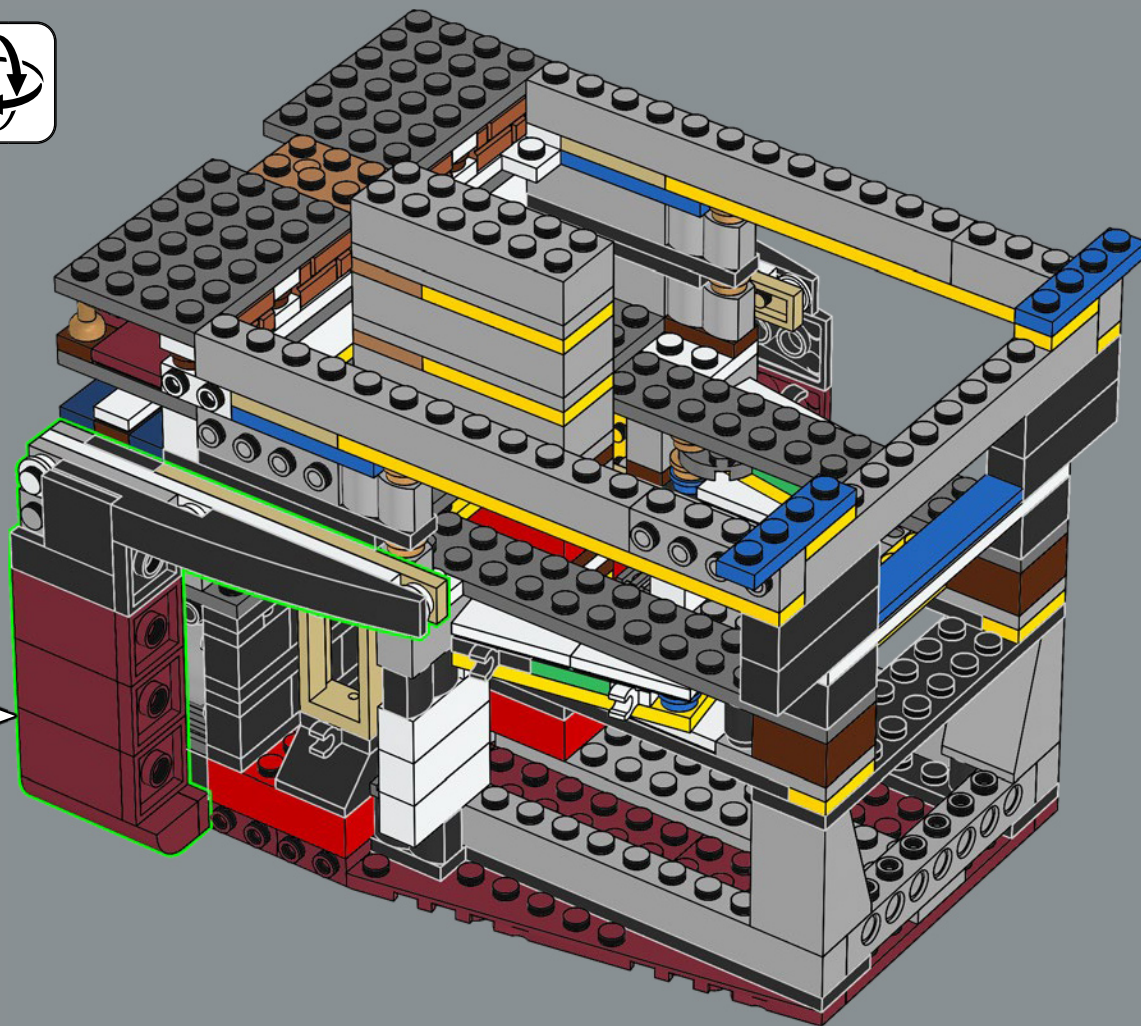

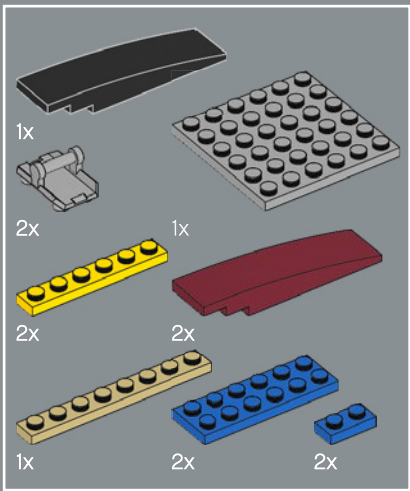

206

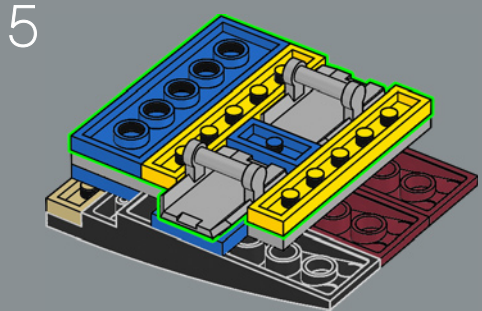
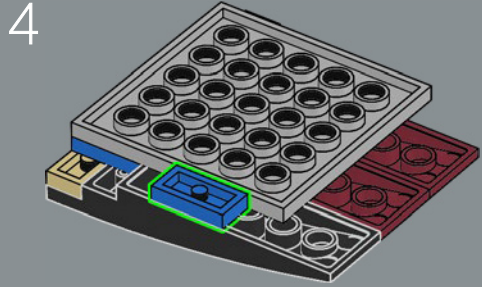
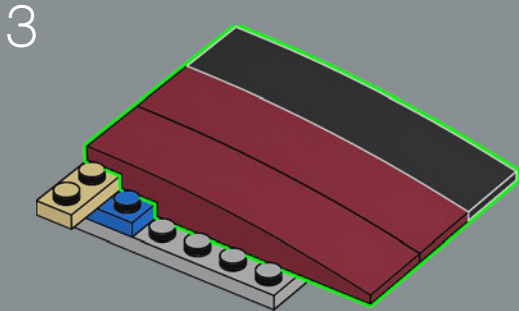
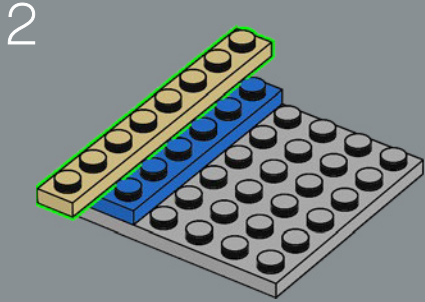
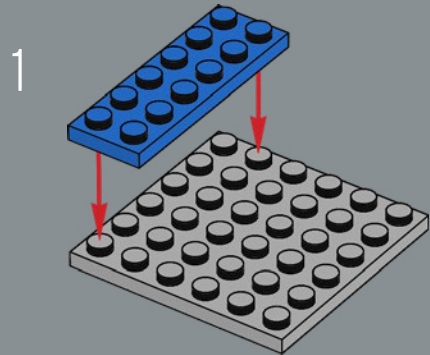

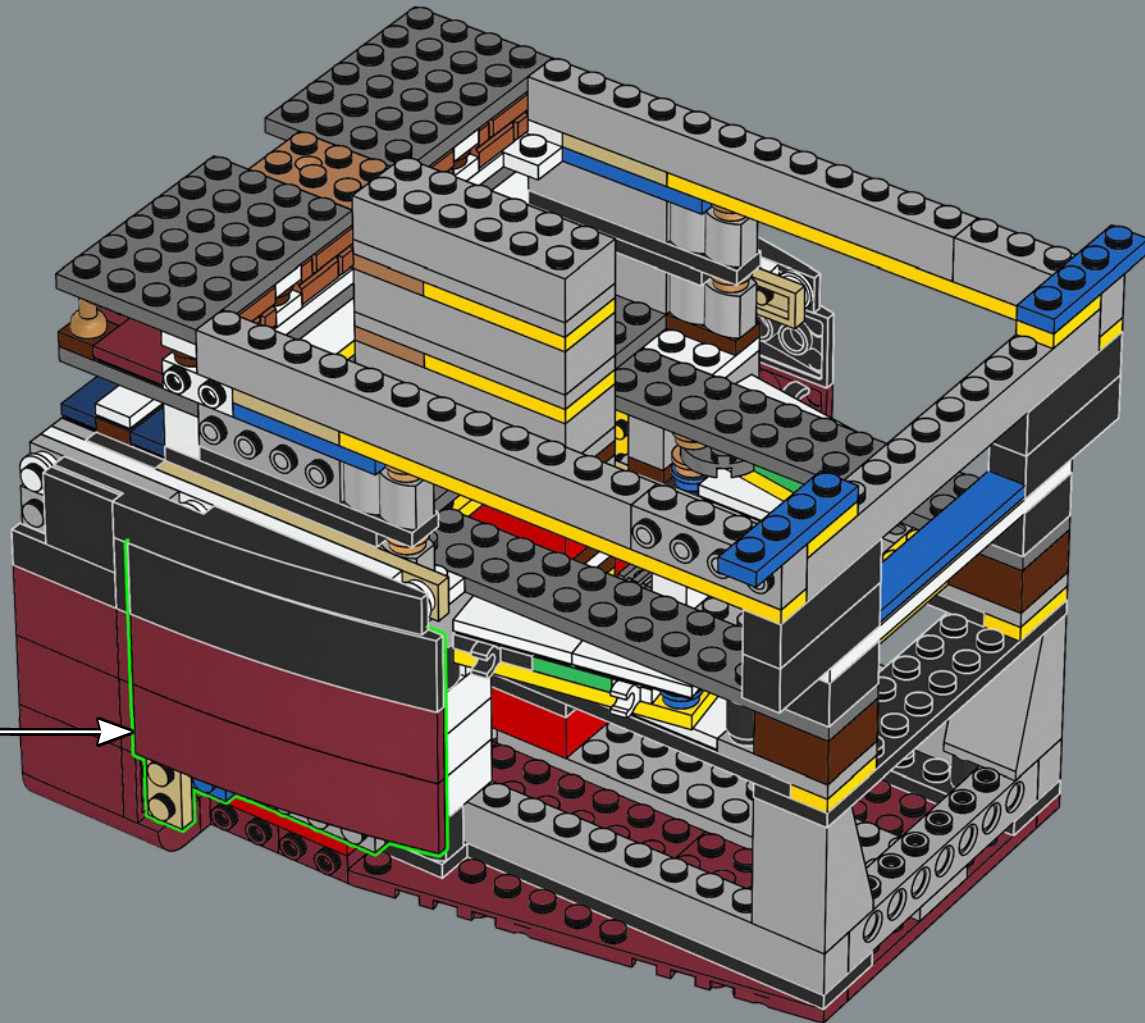

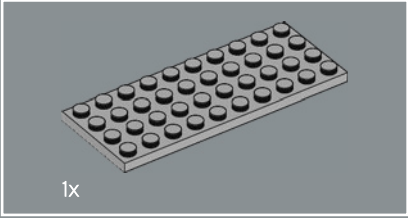
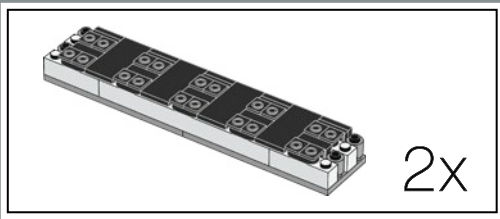

207

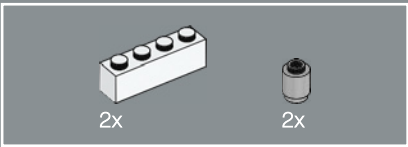
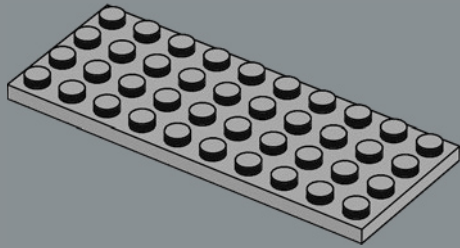

208

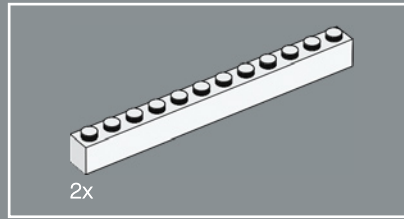
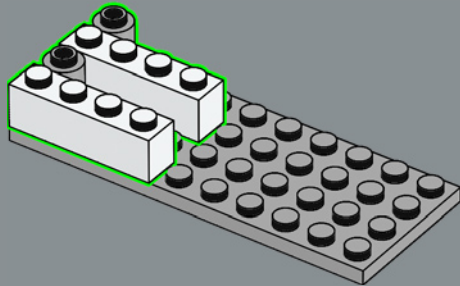

209

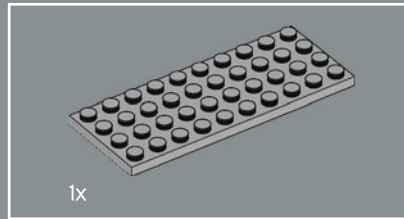
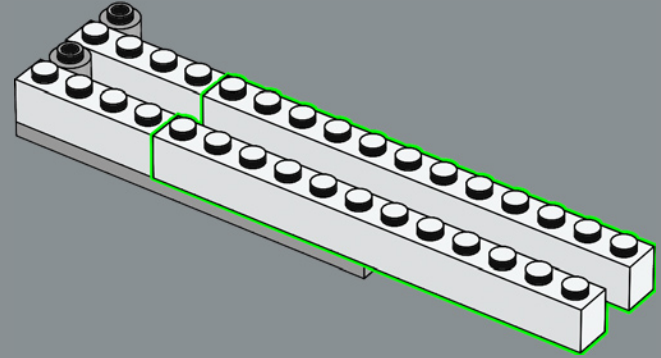

210

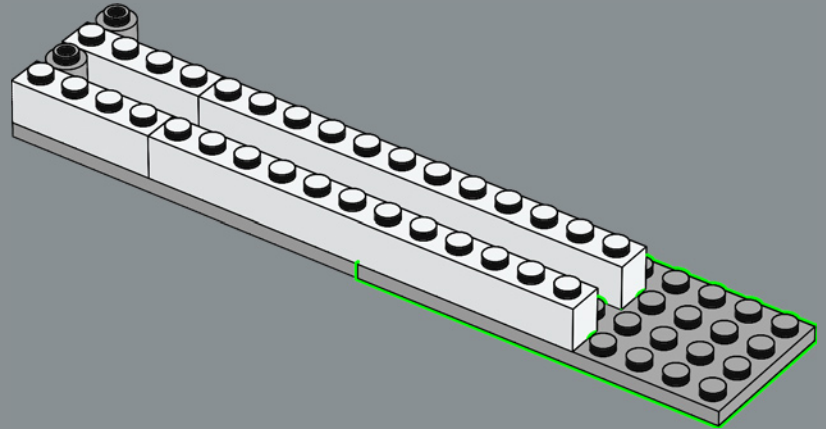



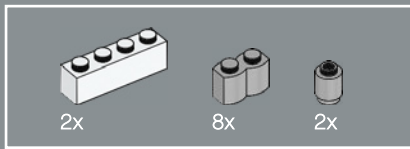

211

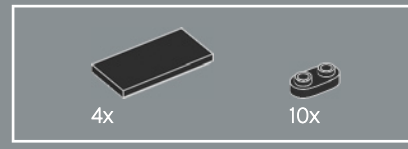
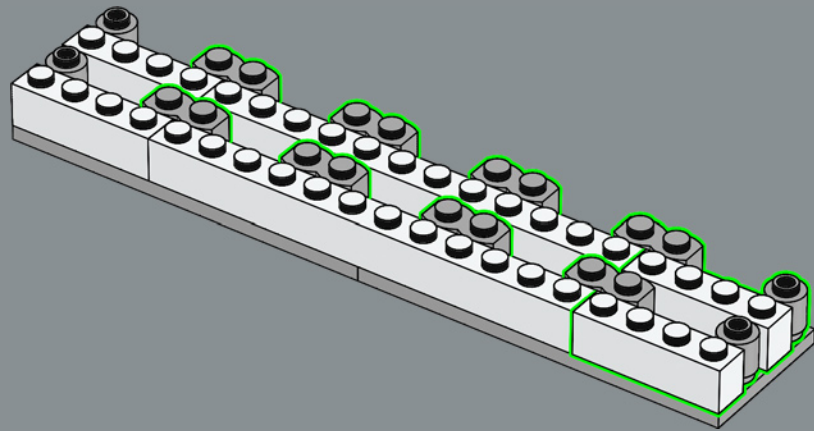

212

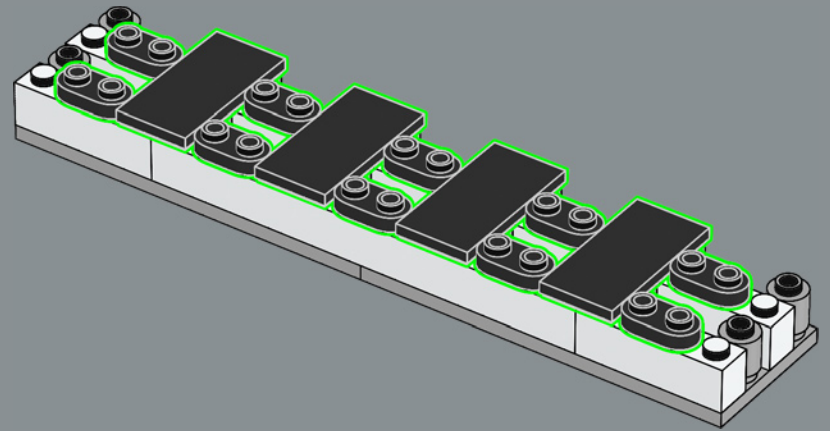

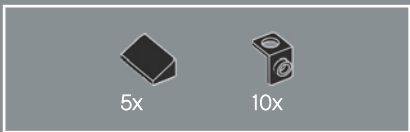

213

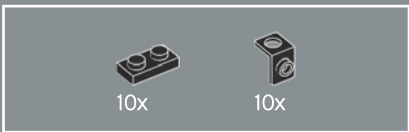
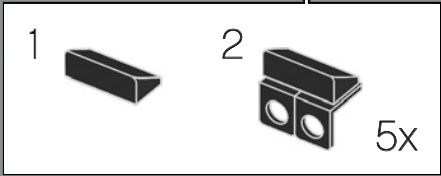
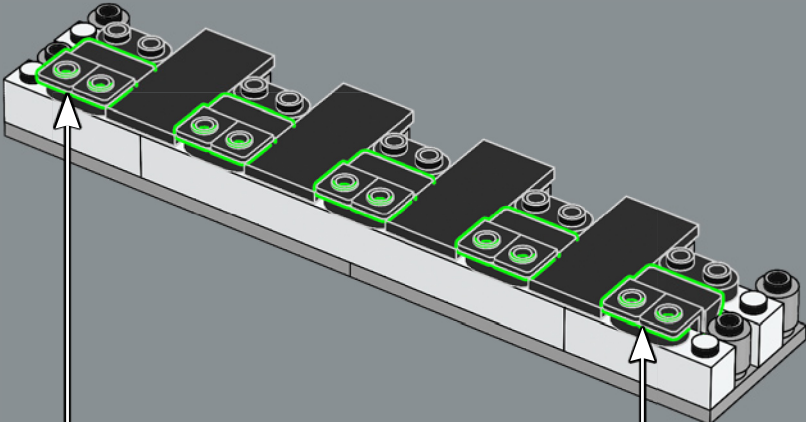

214

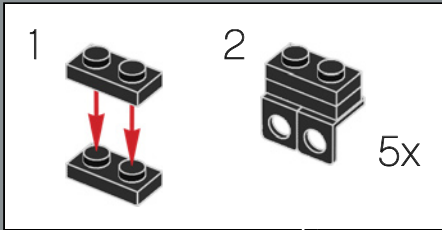
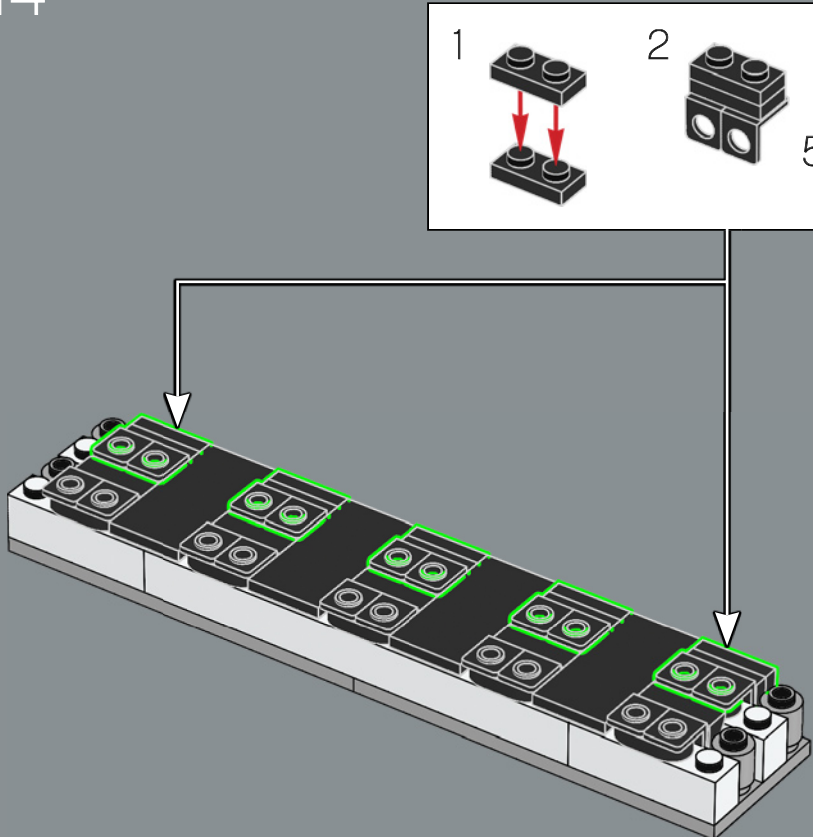

2x

215

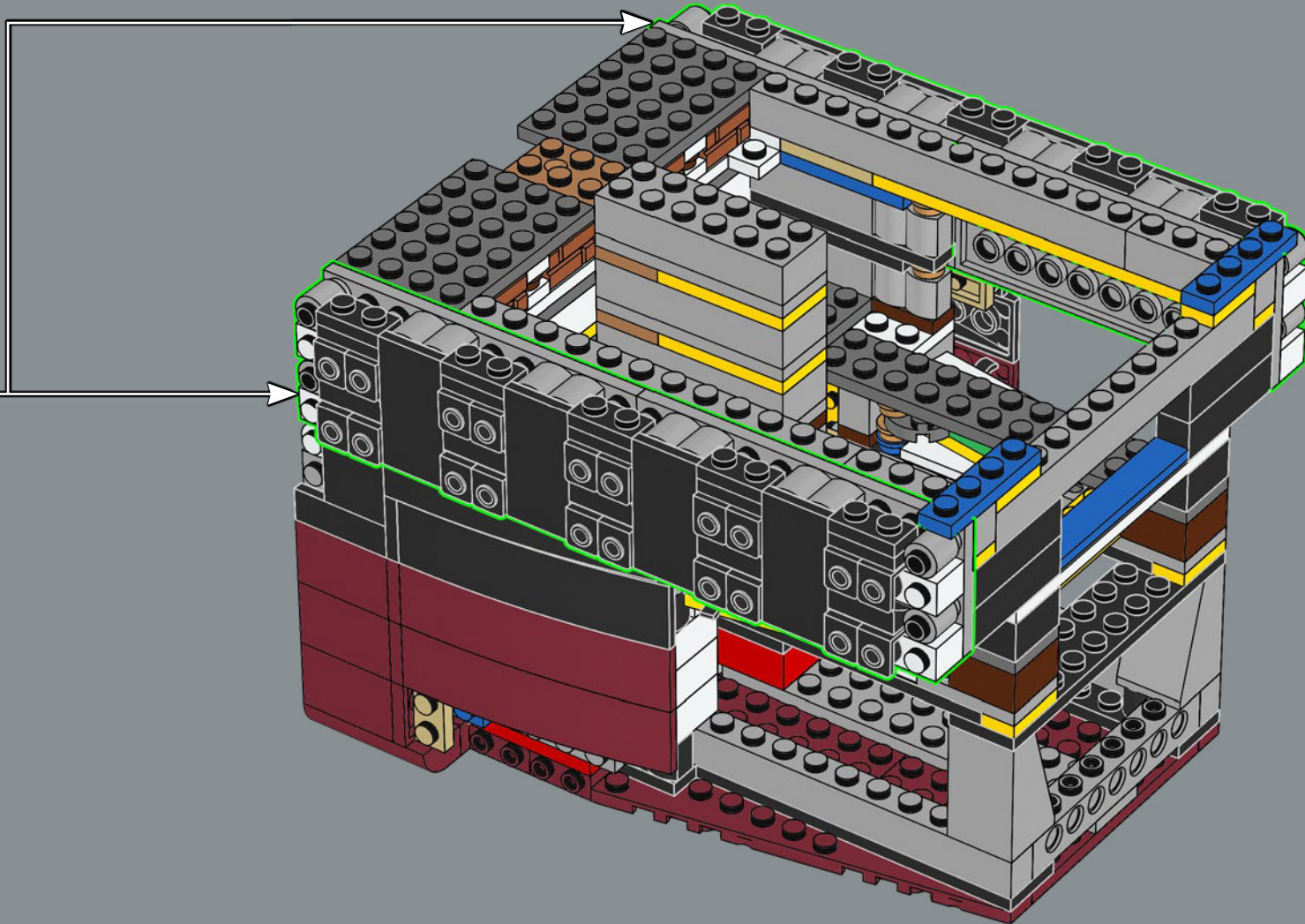

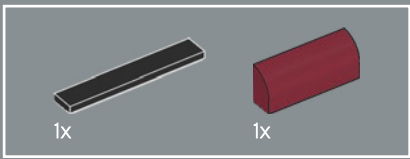

216

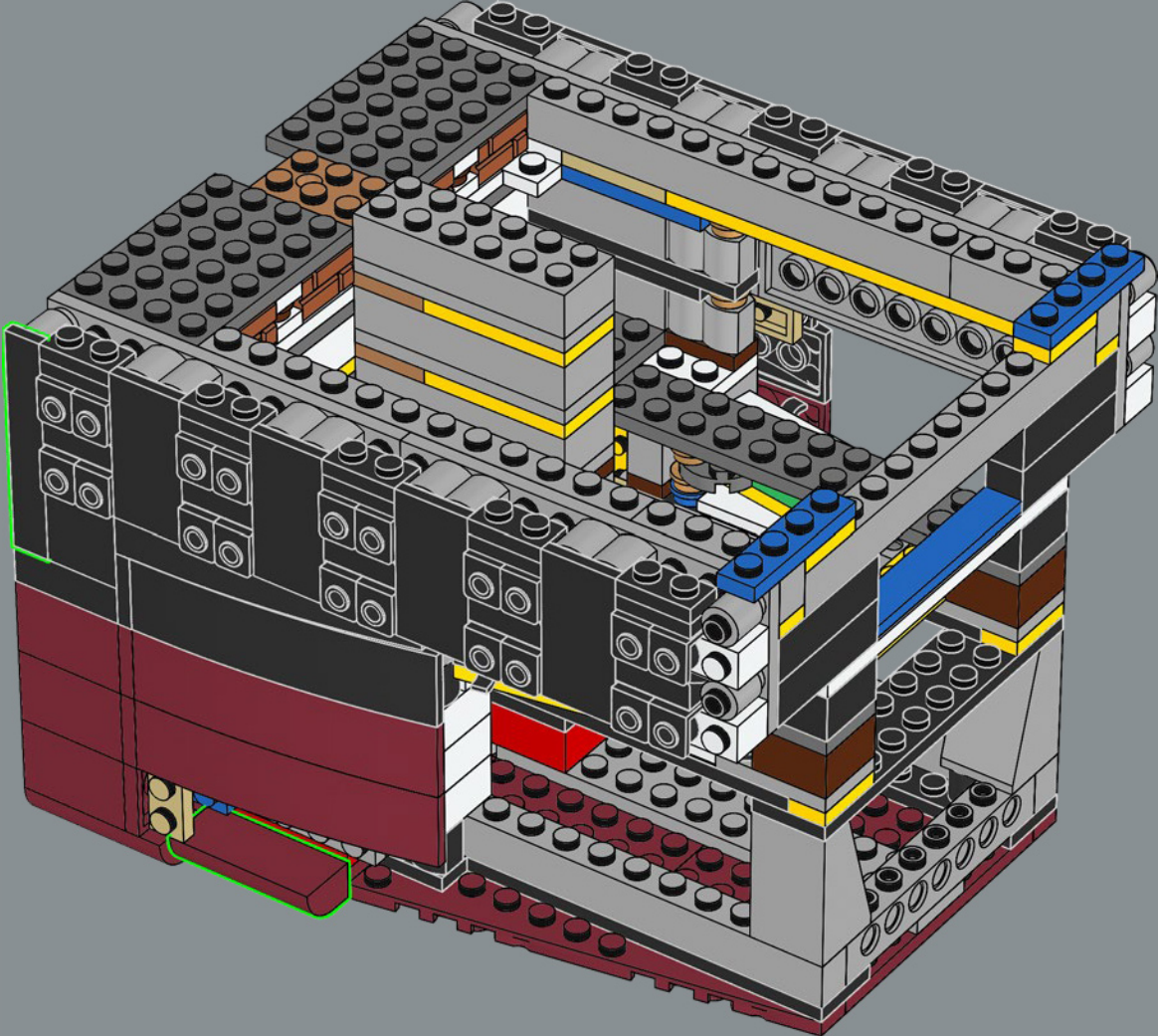

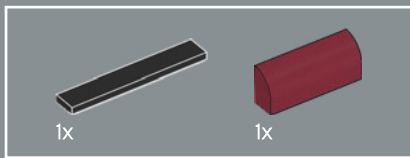

217

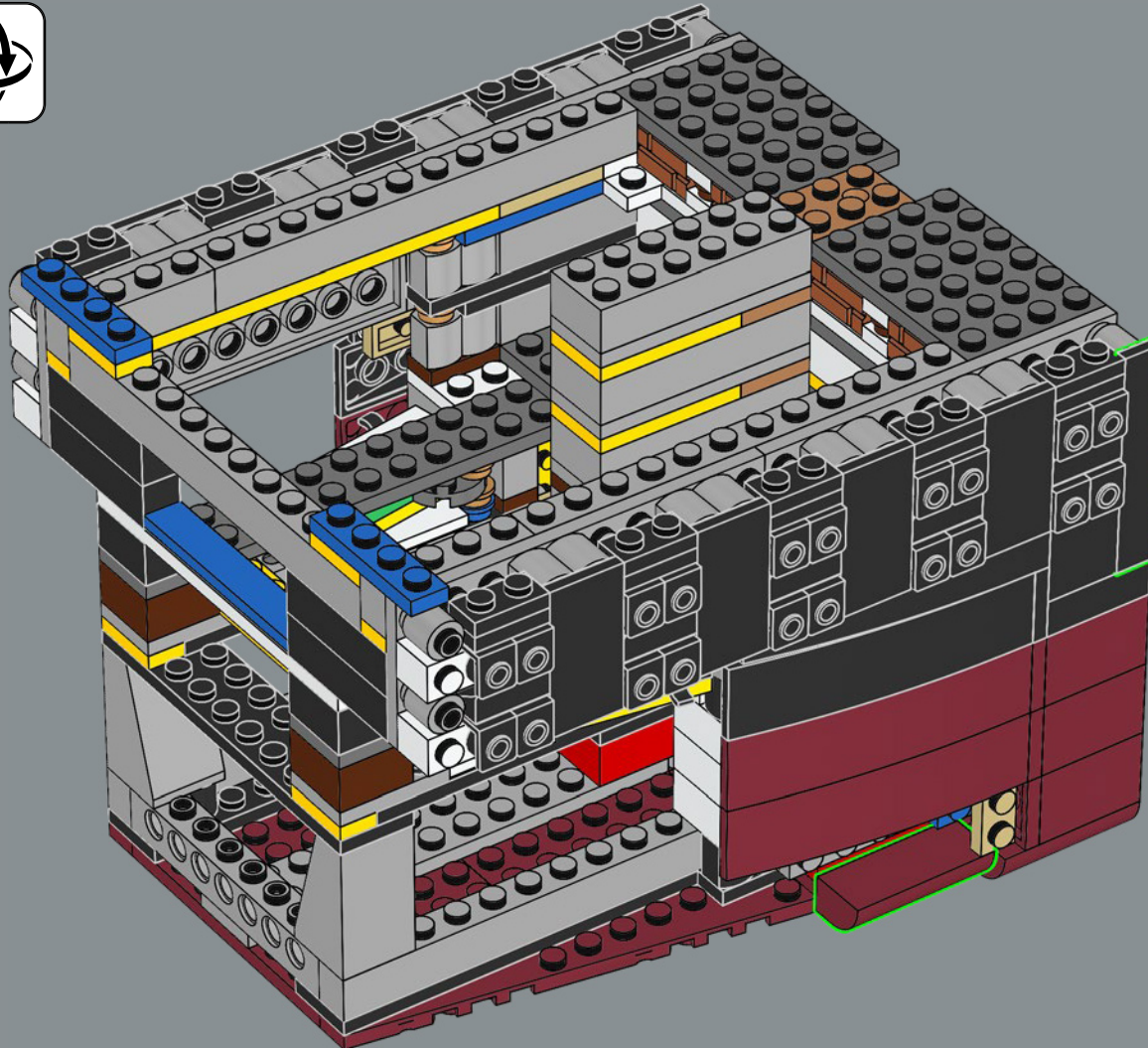

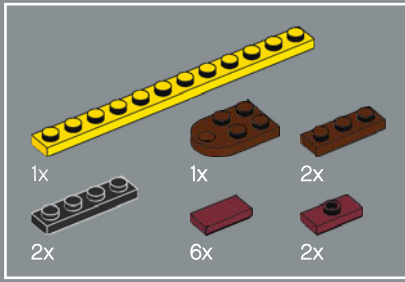
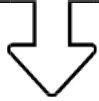

218

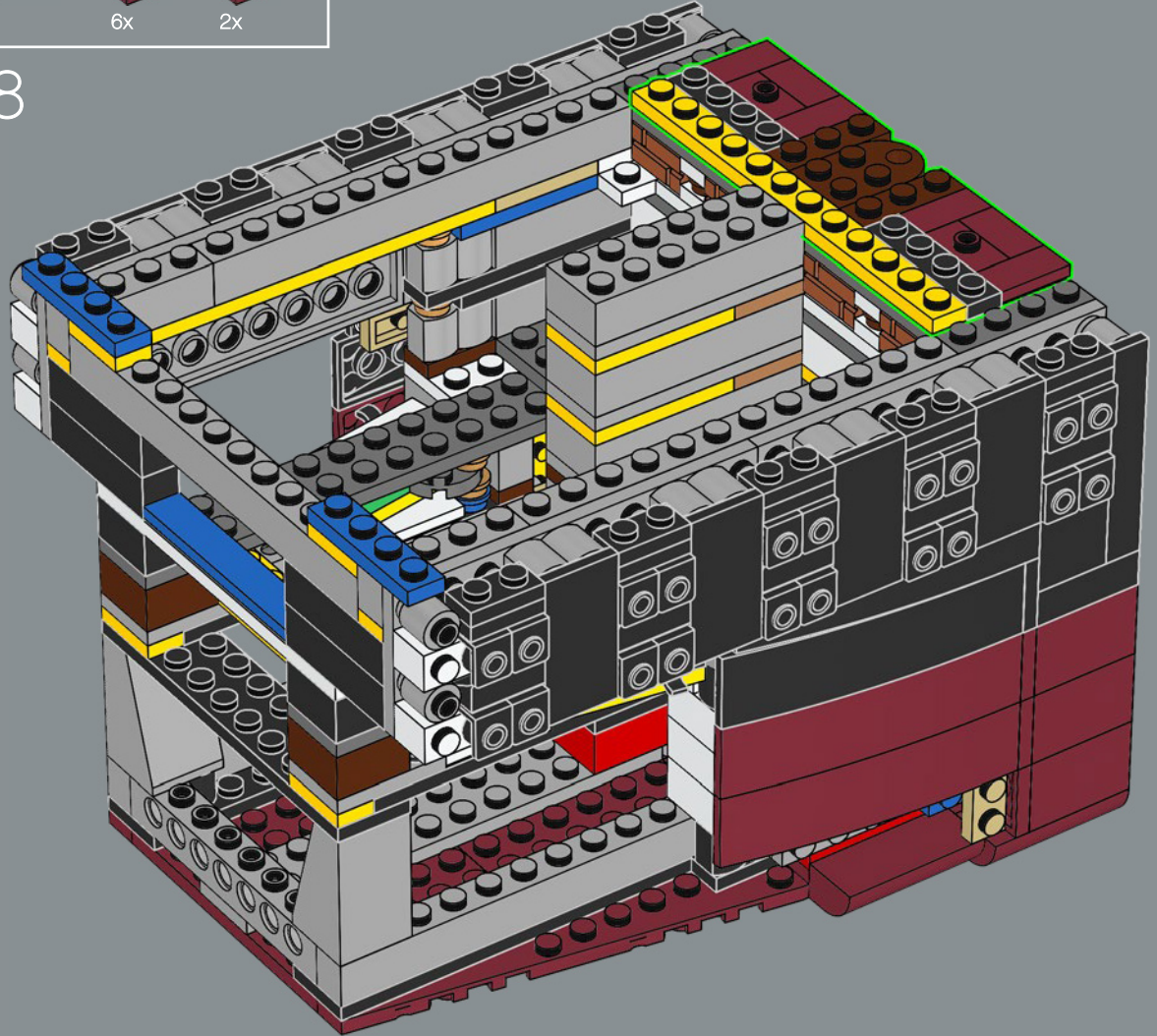



219

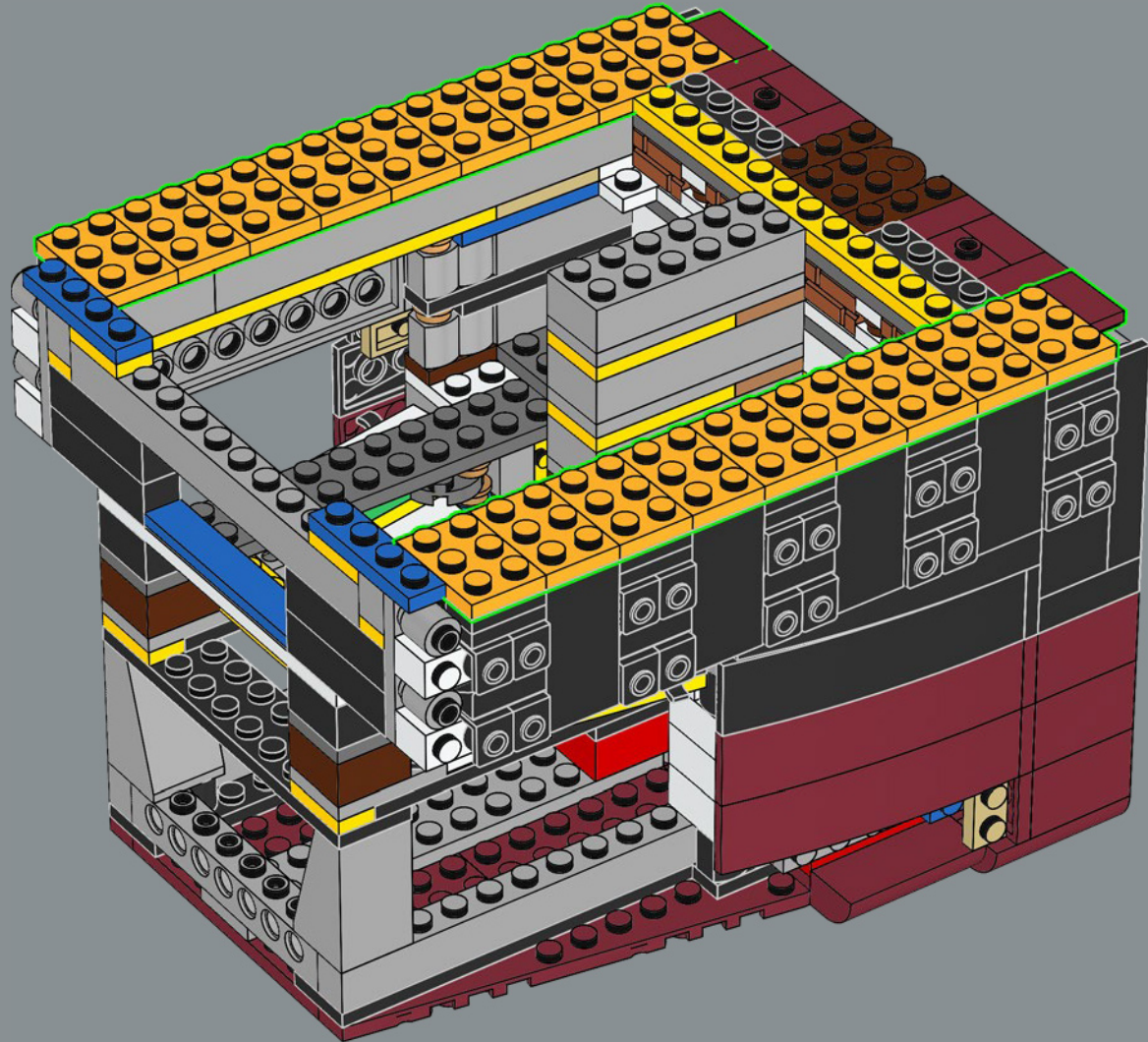

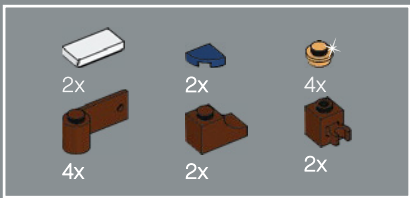

220

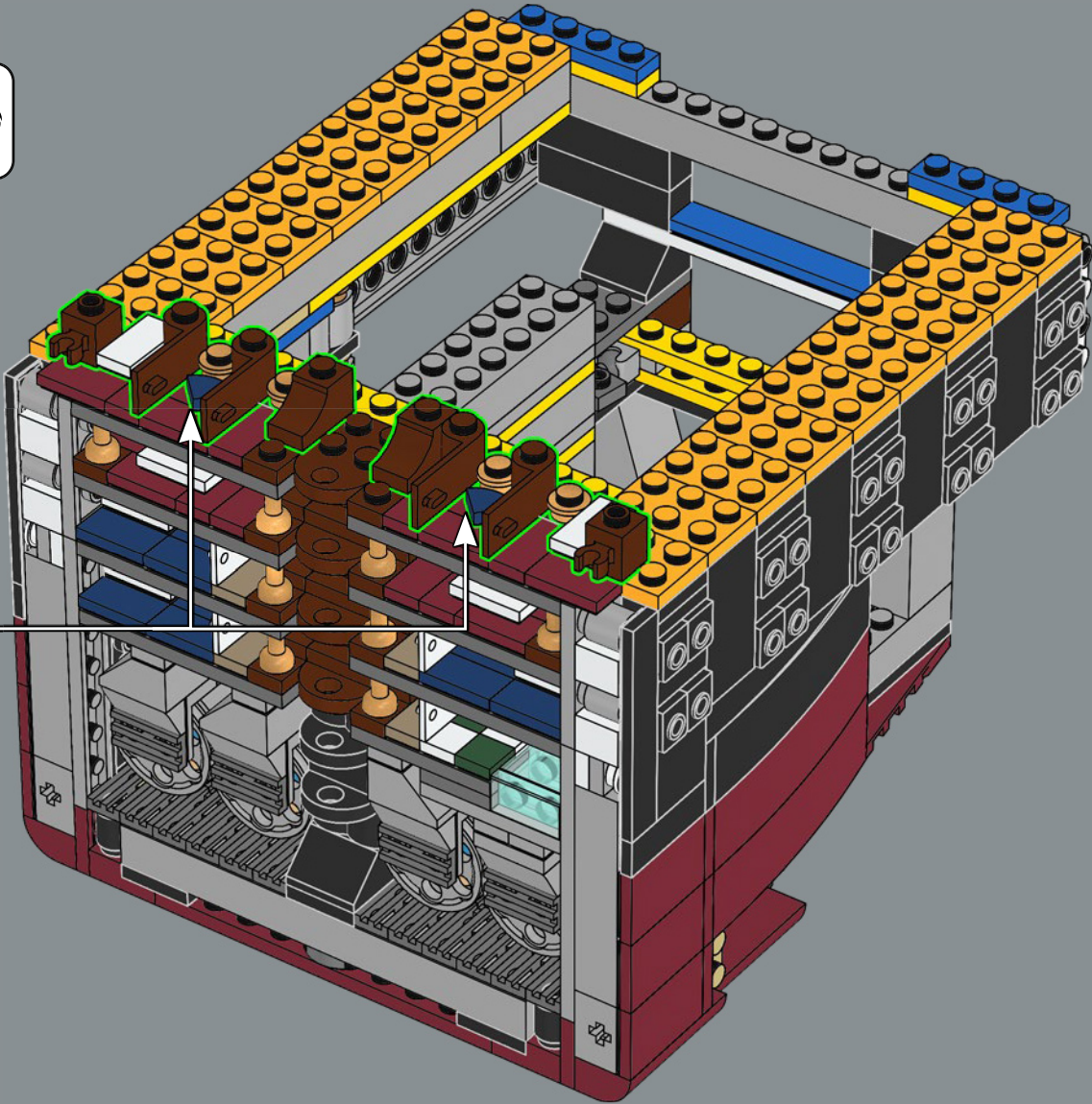



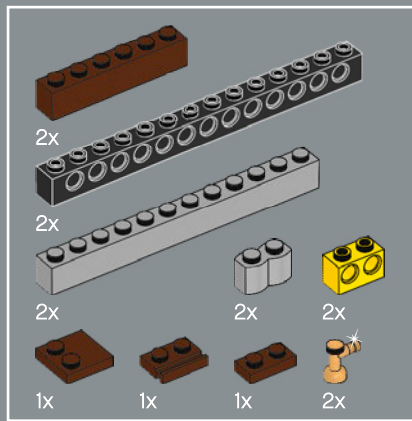

221

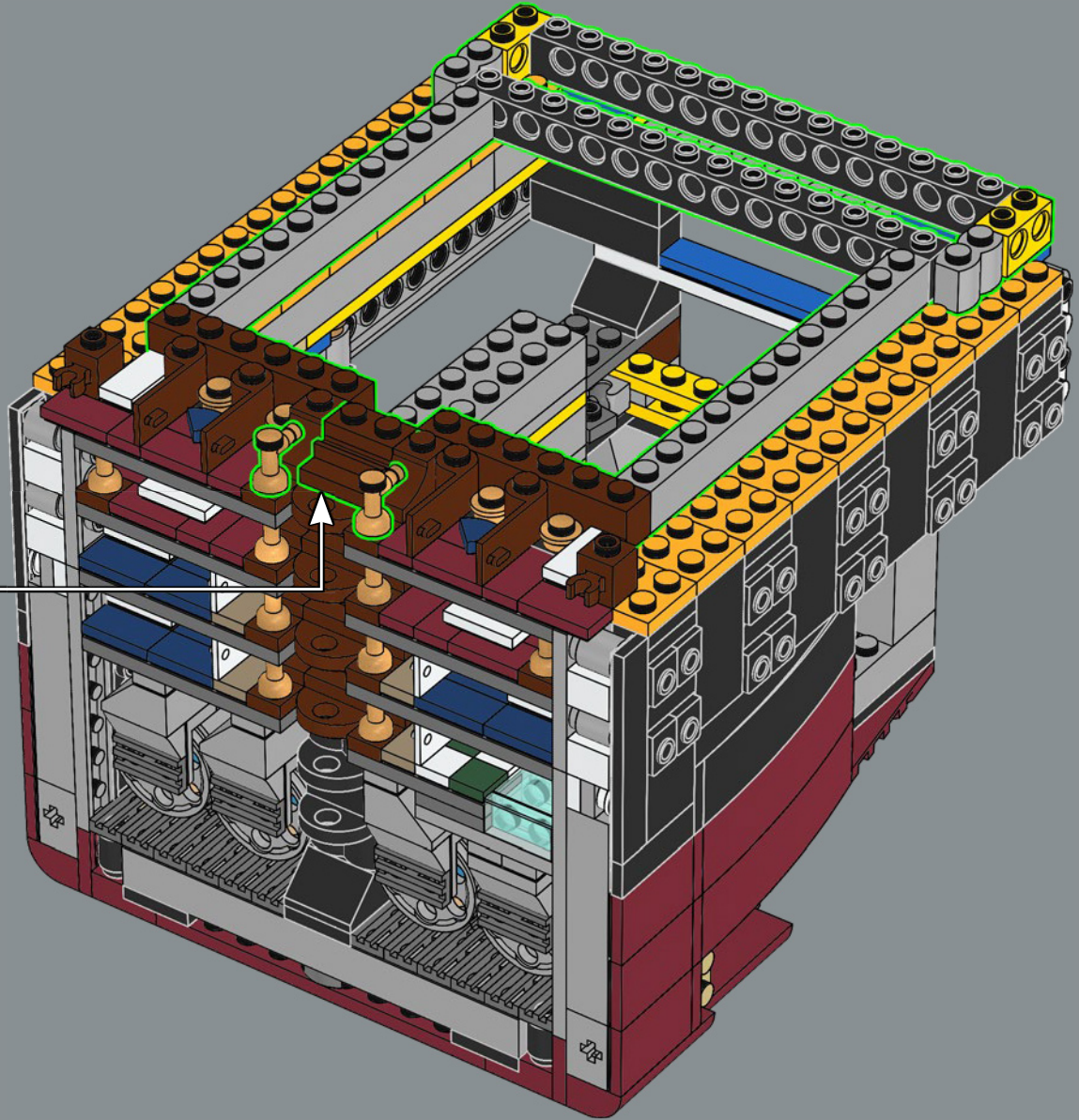
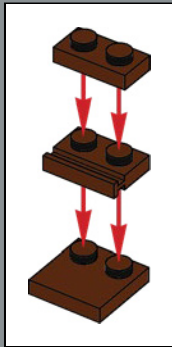

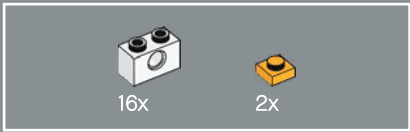

222

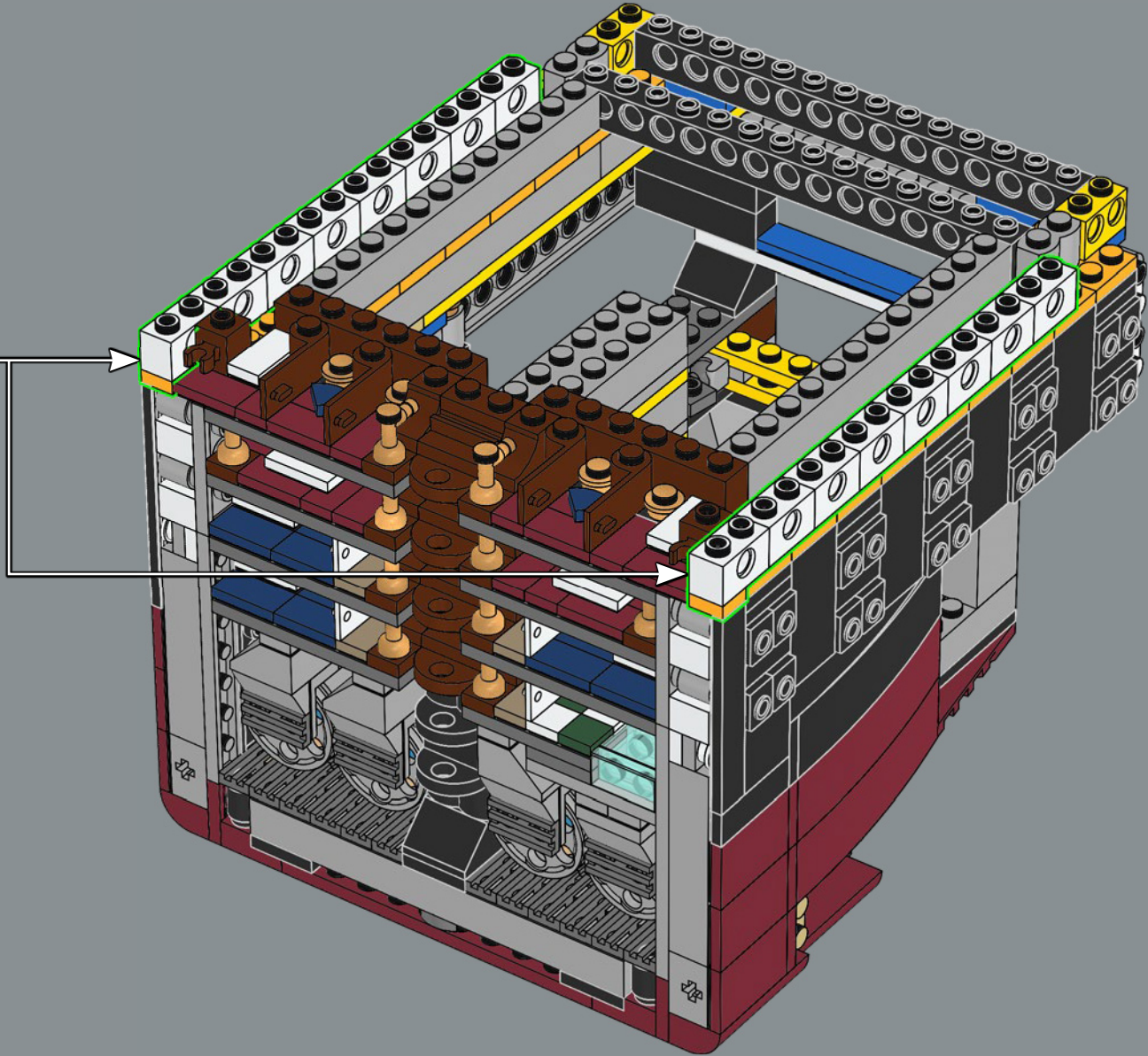
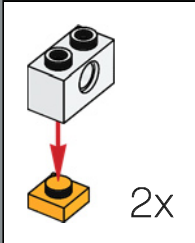

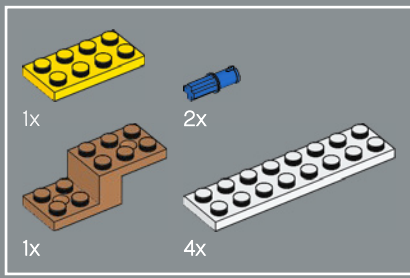

223

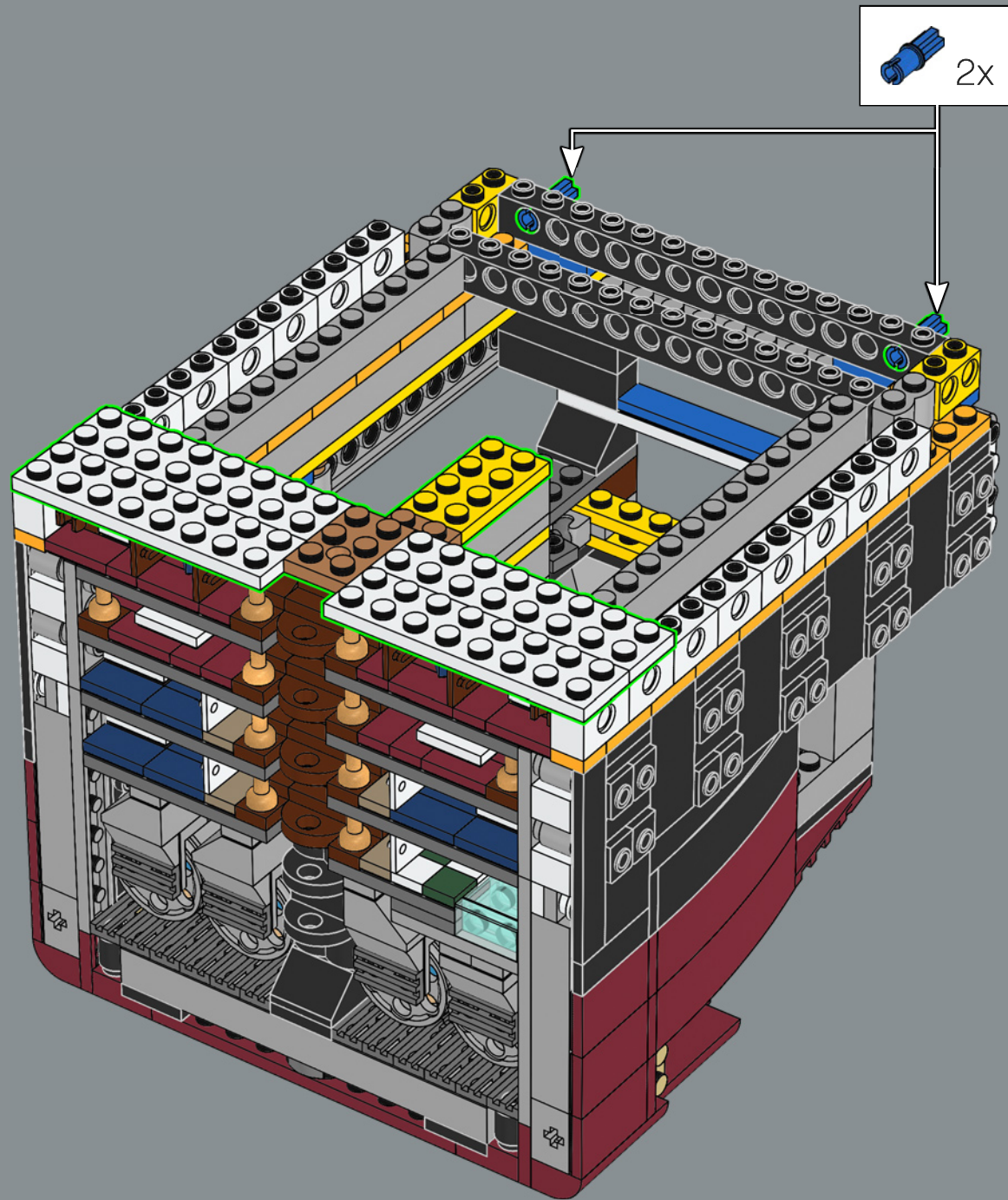

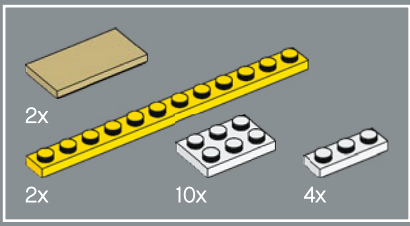

224

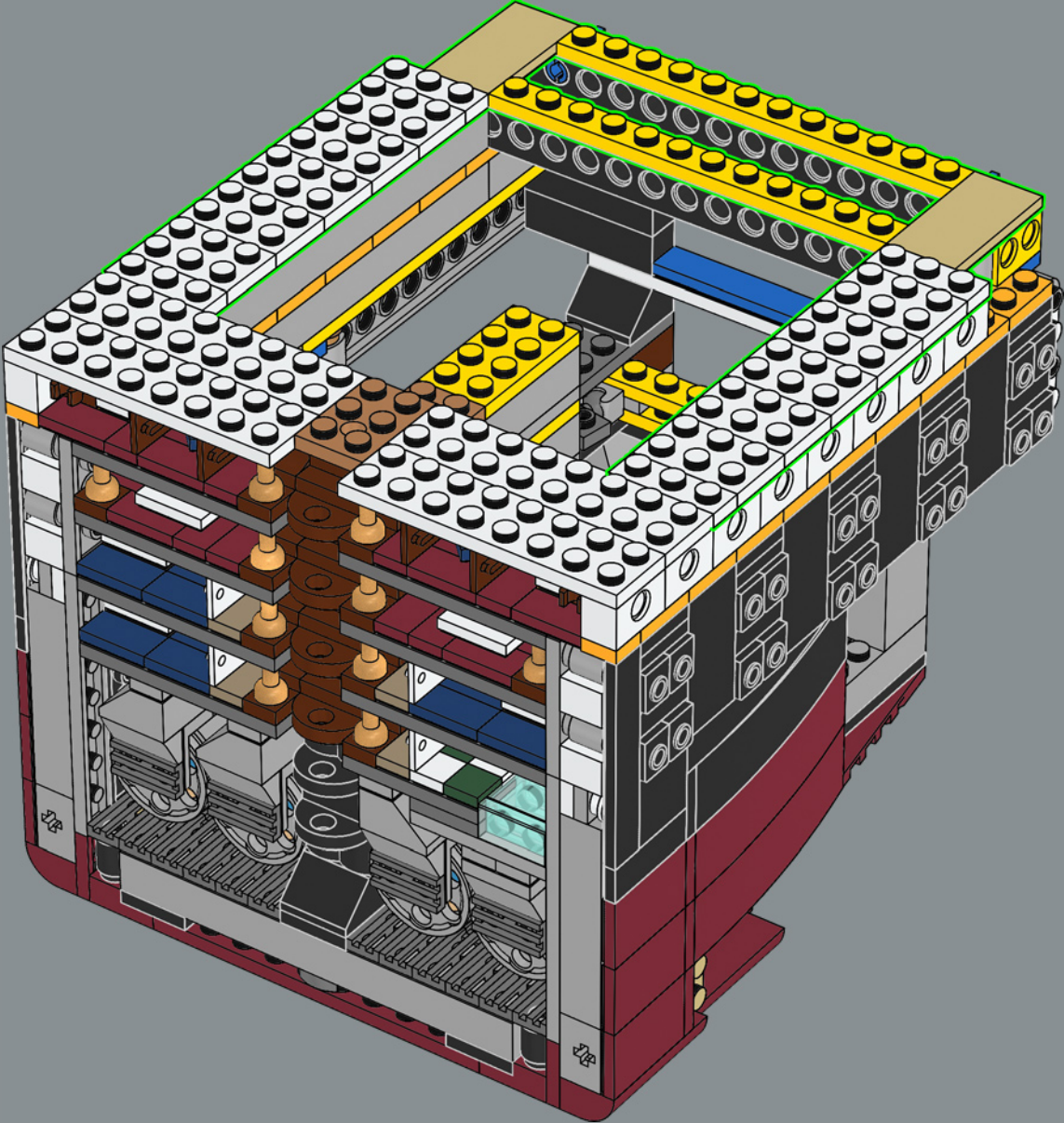

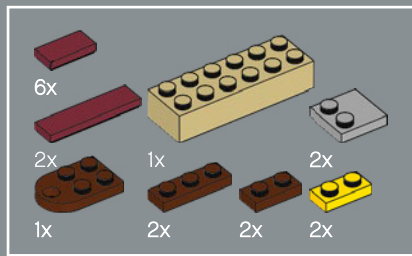

225

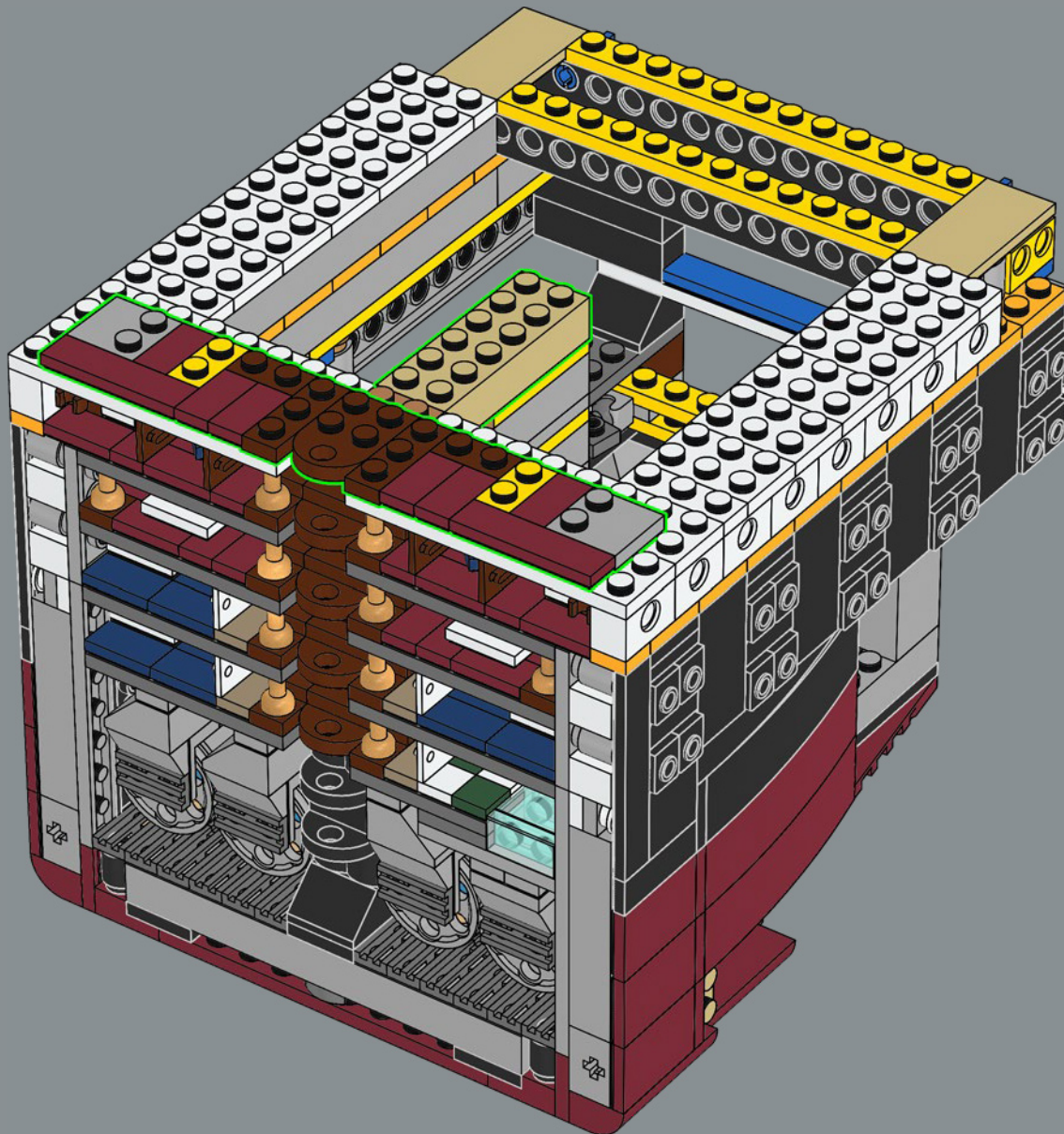

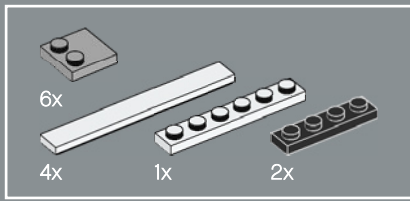

226

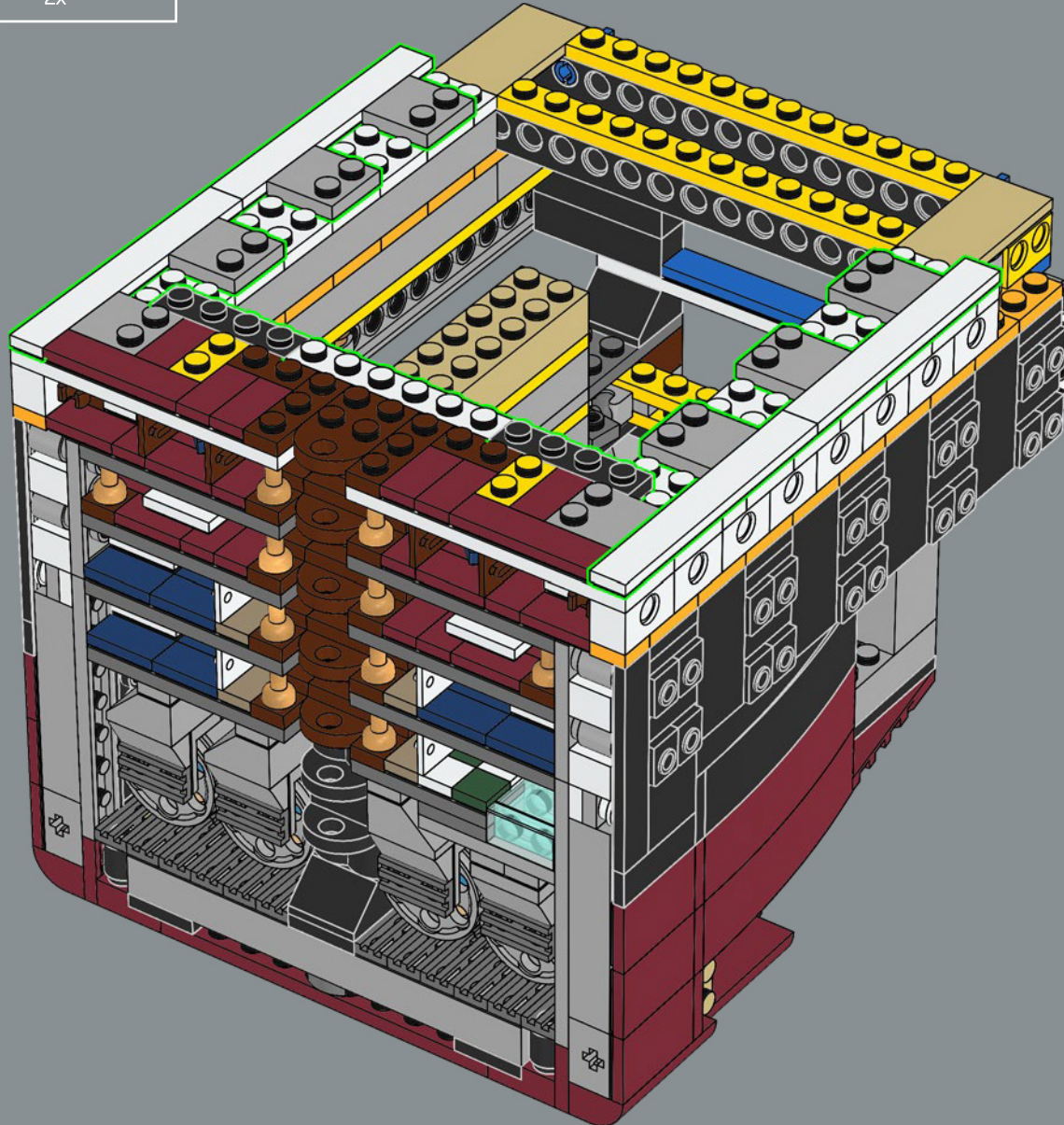

Als „königliches Postschiff“ (RMS steht für Royal Mail Ship) beförderte die RMS Titanic jede Menge Fracht und Post für die Royal Mail und den US Postal Service.



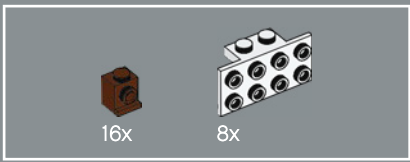

228

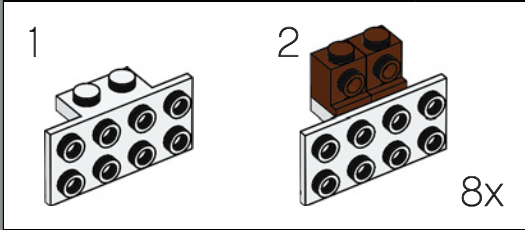
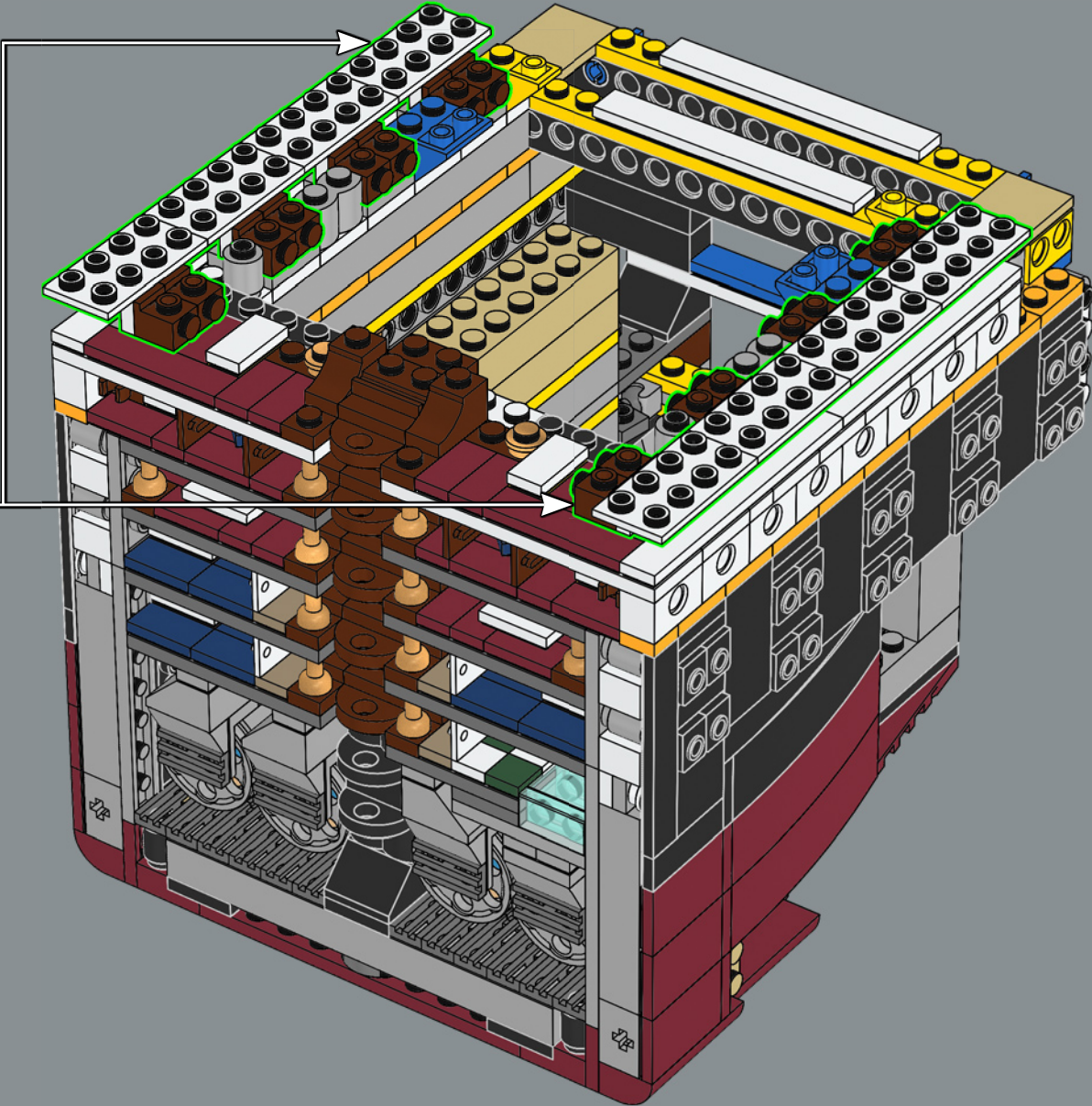



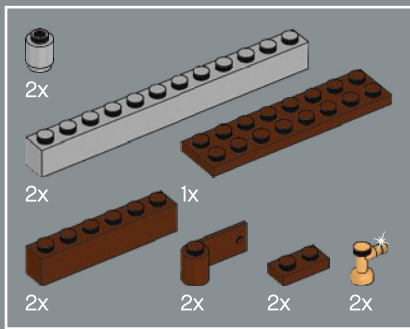

229

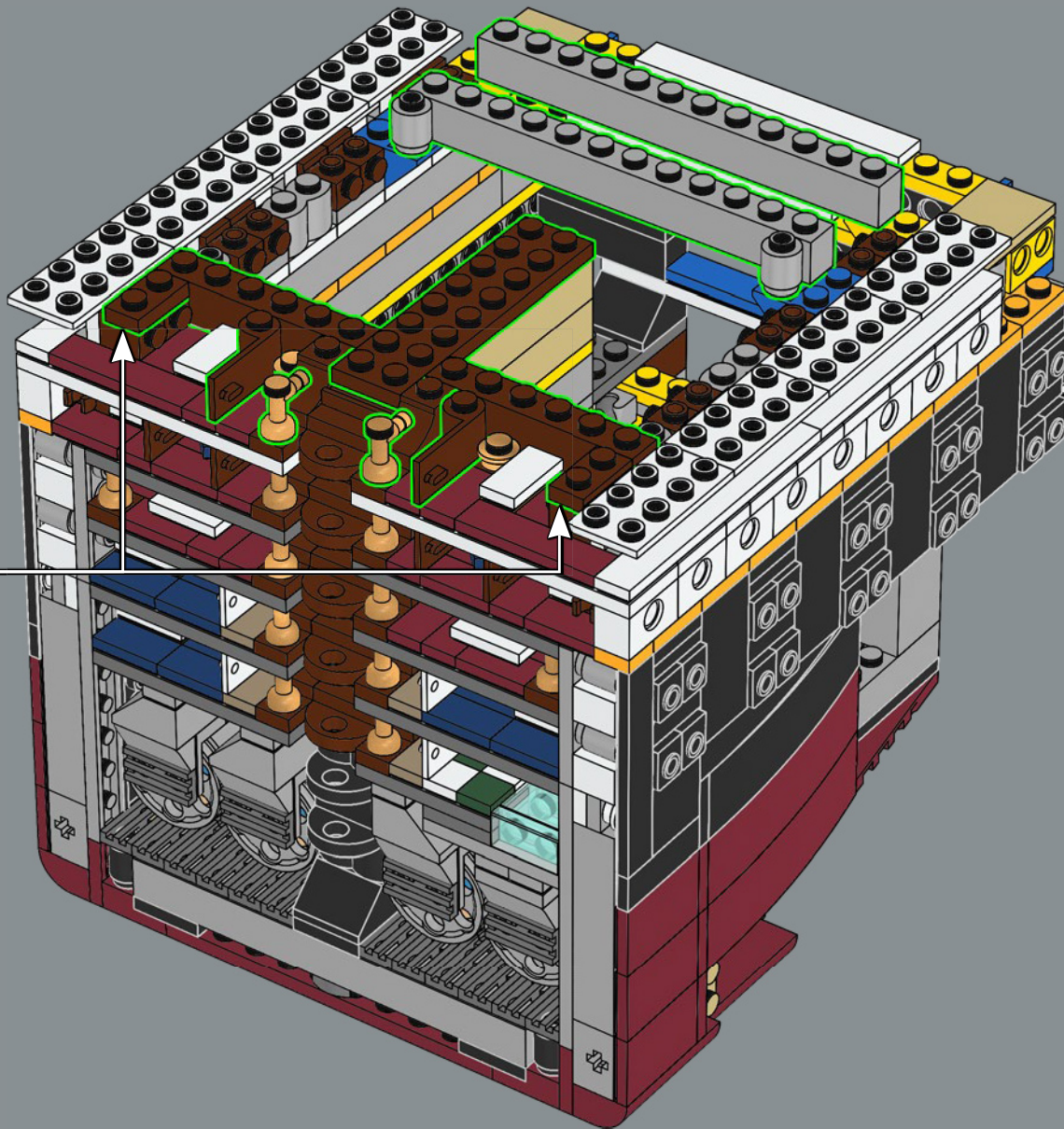

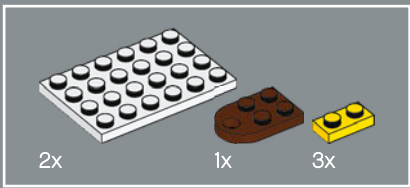

230

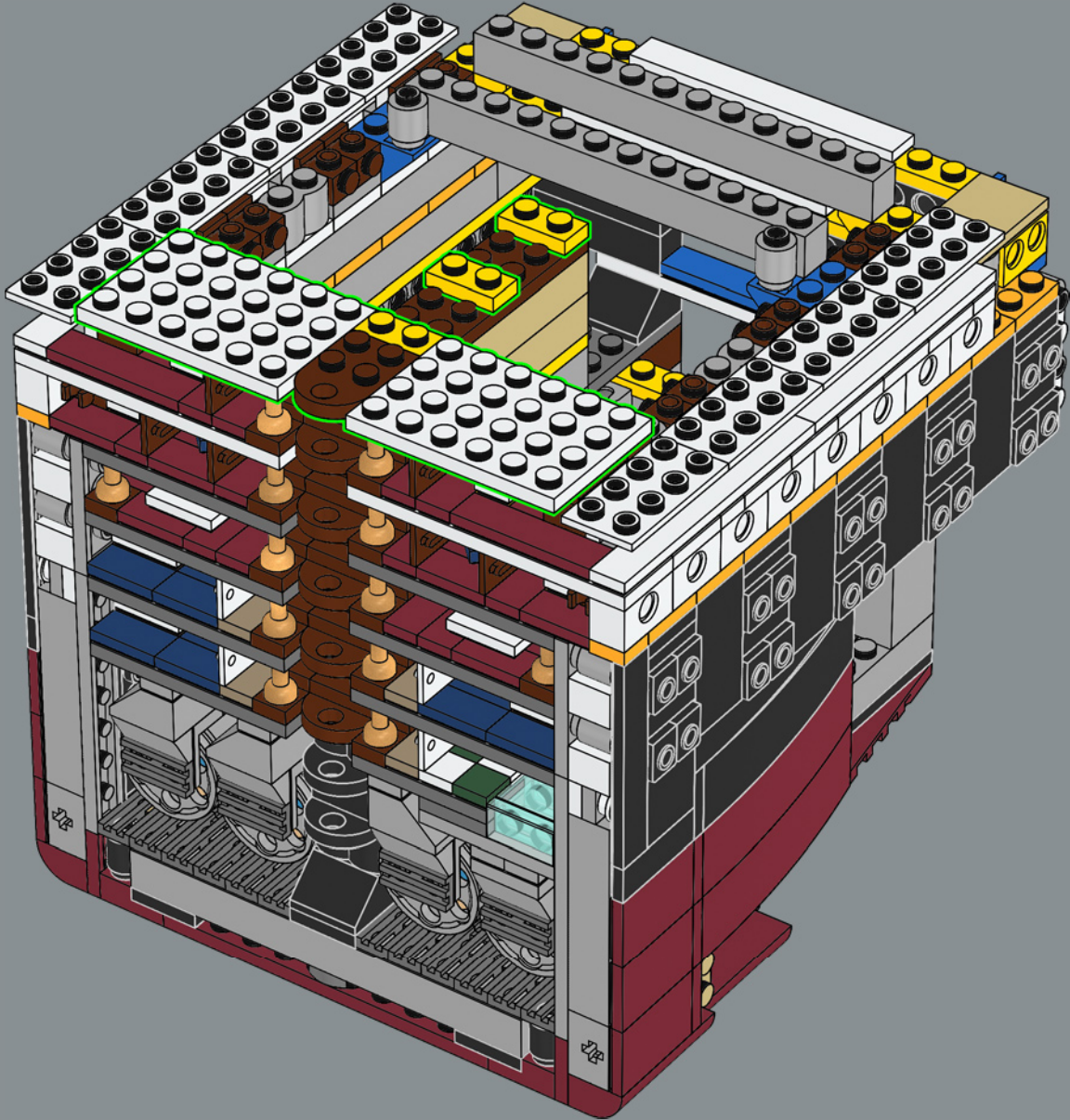

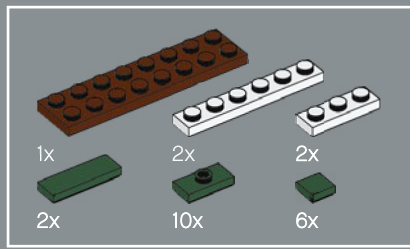

231

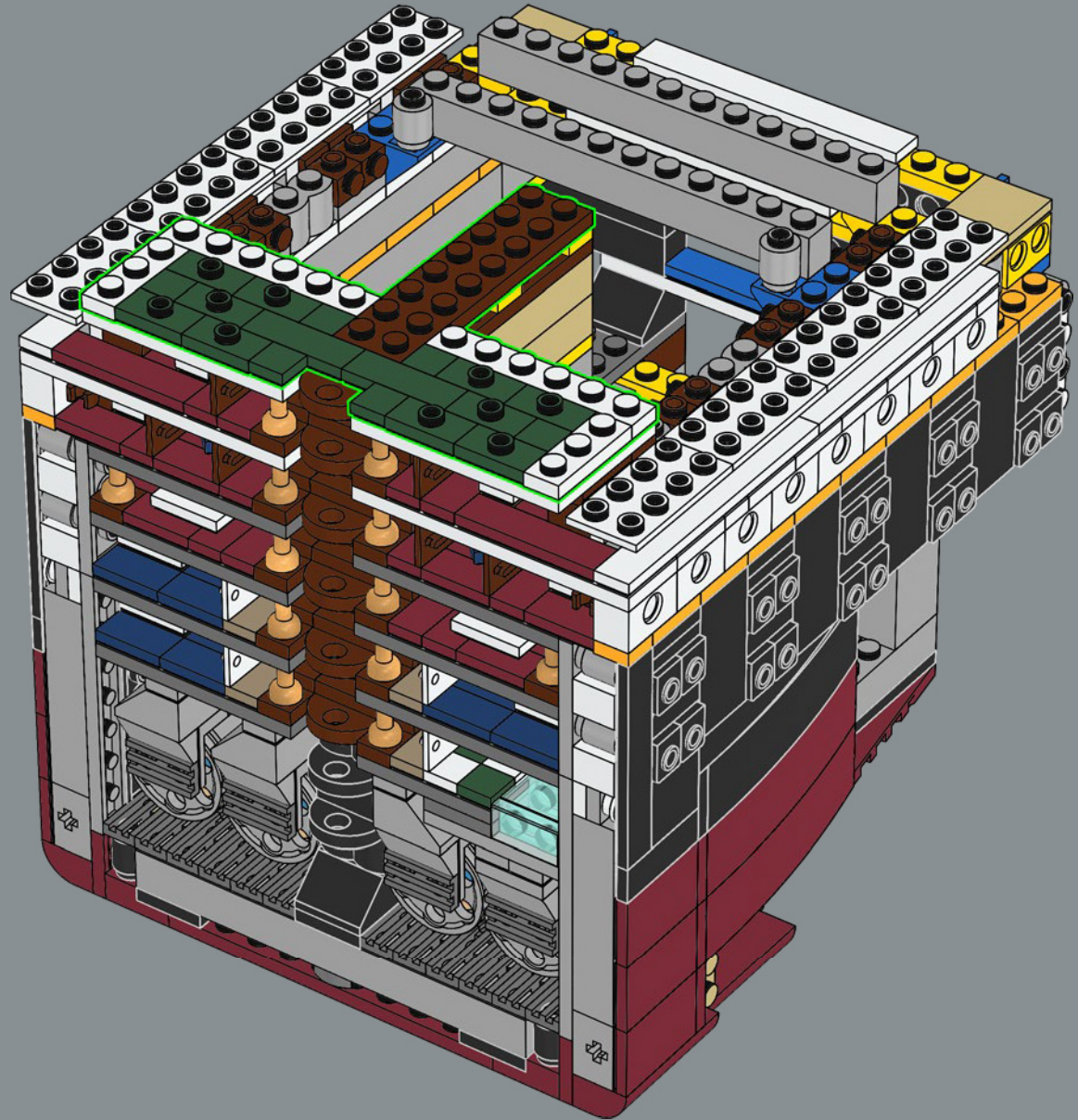

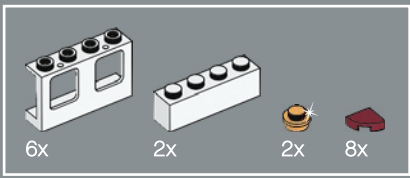

232

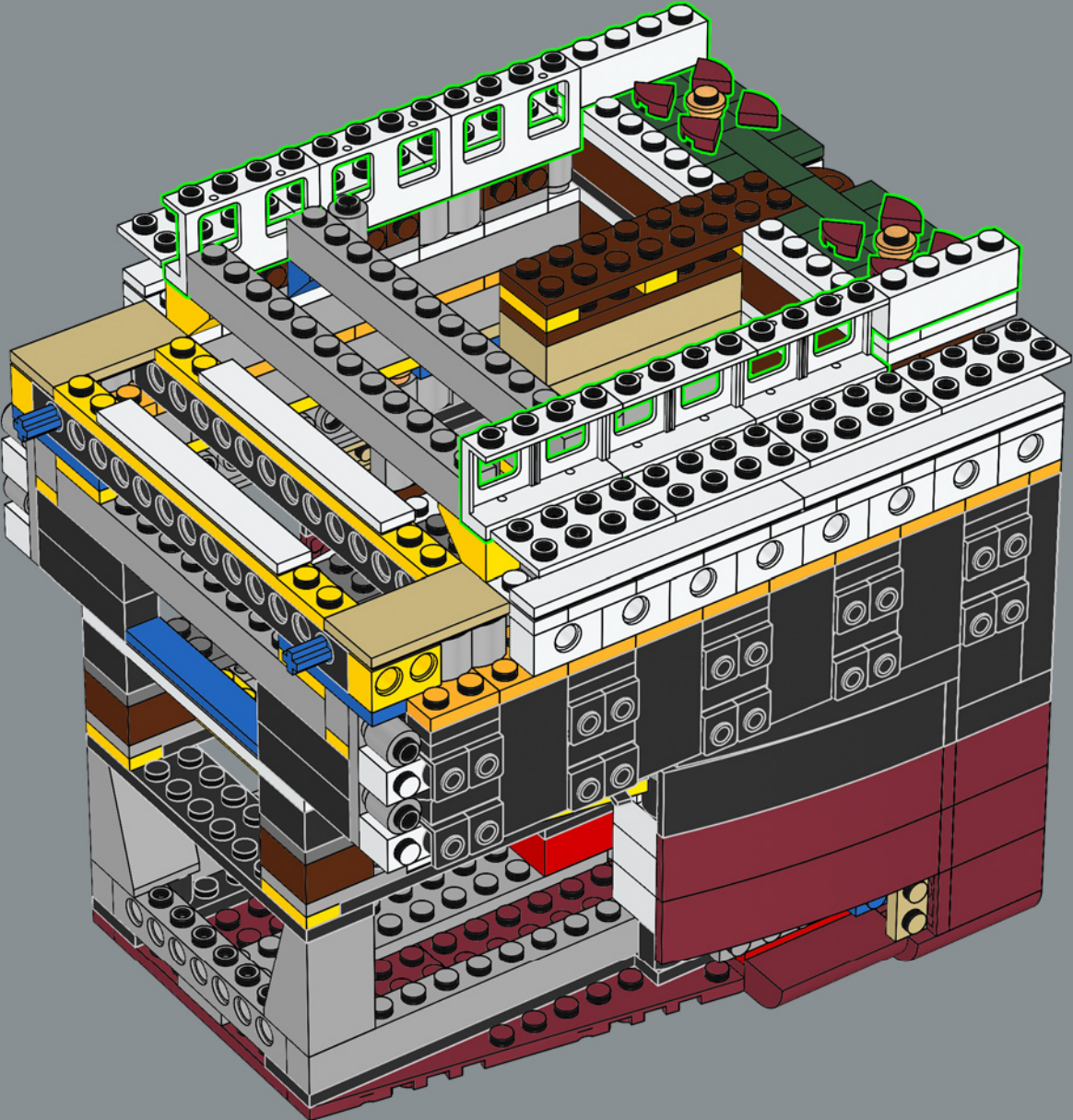

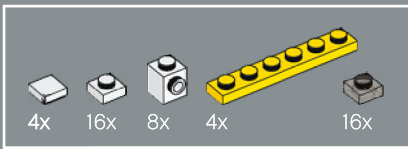

233

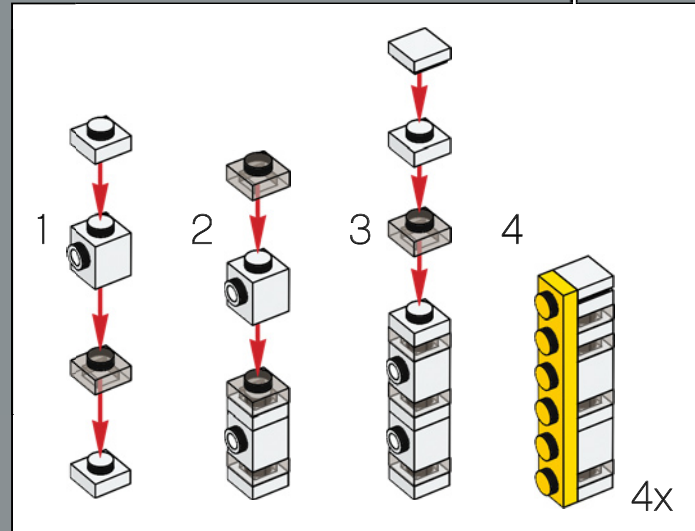
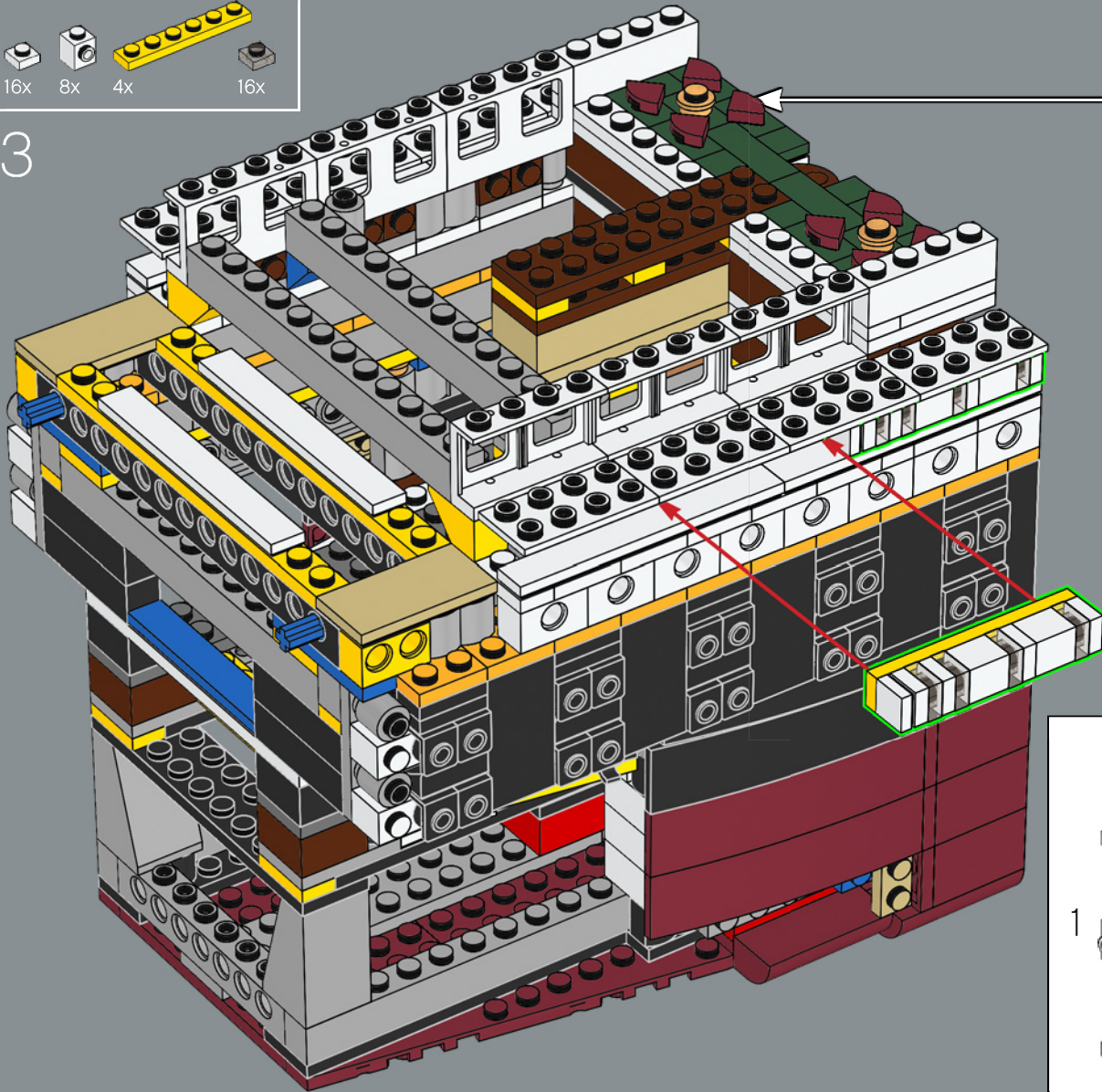

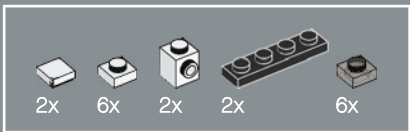

234

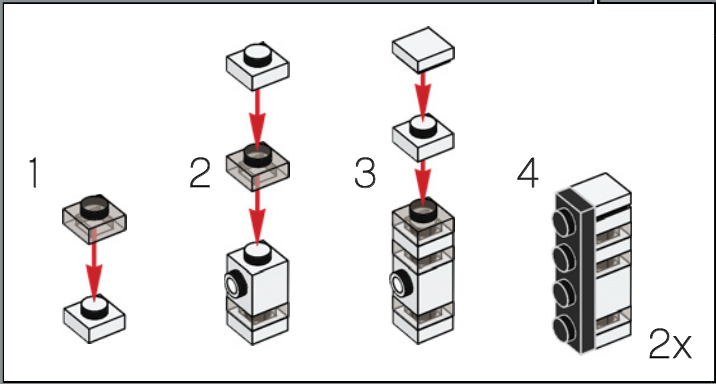
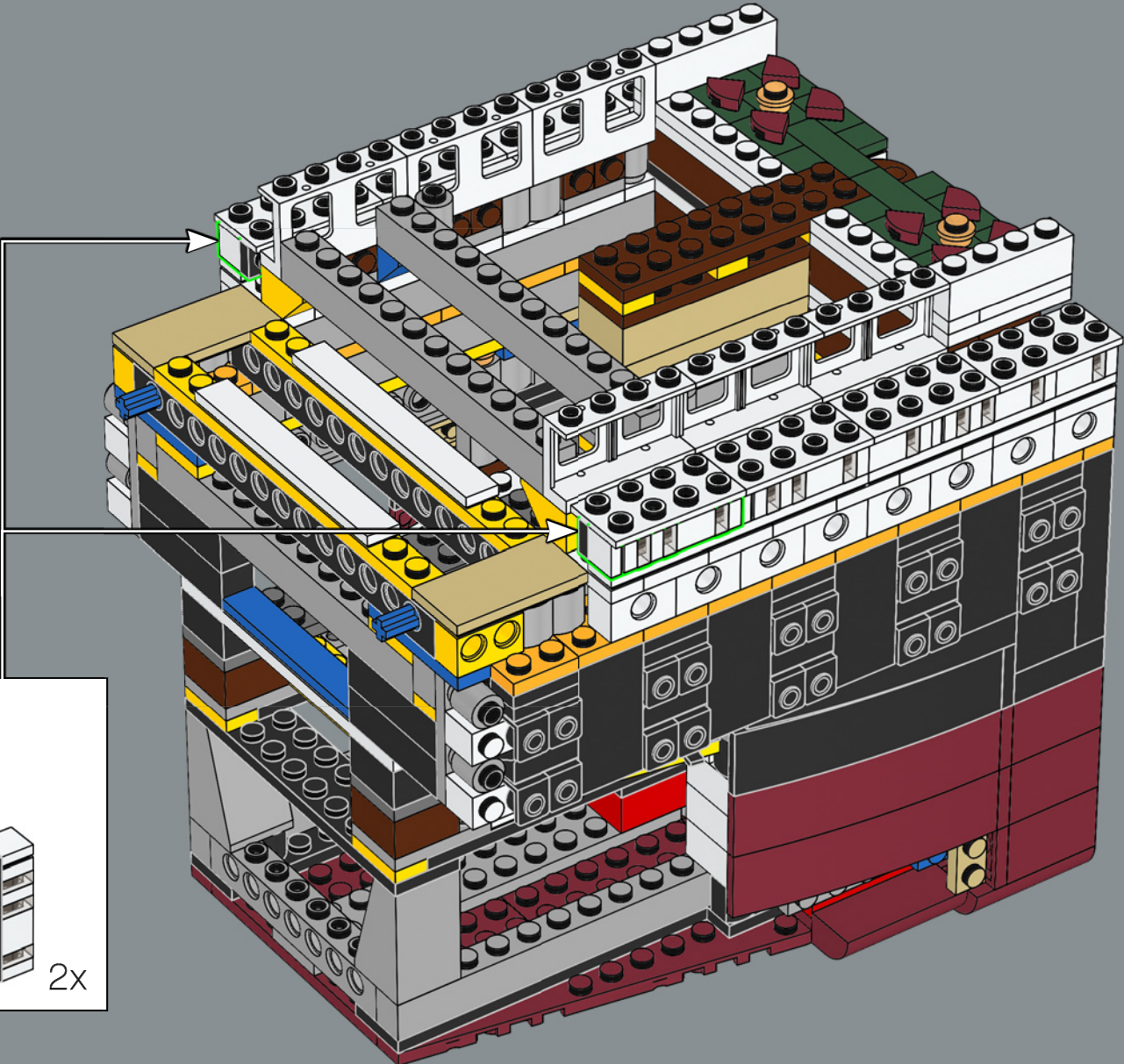

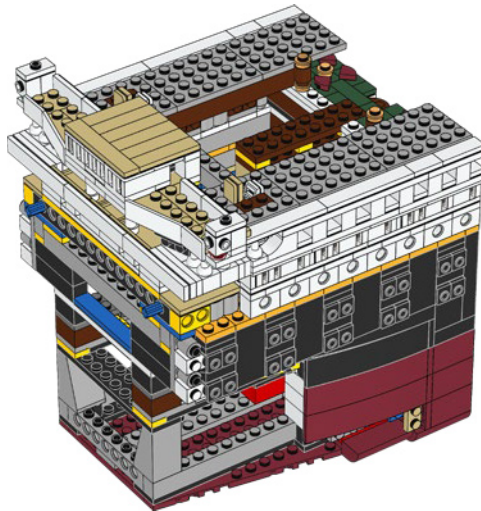
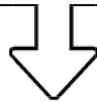

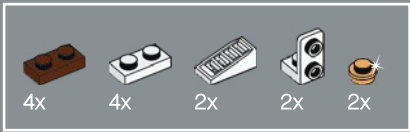

235

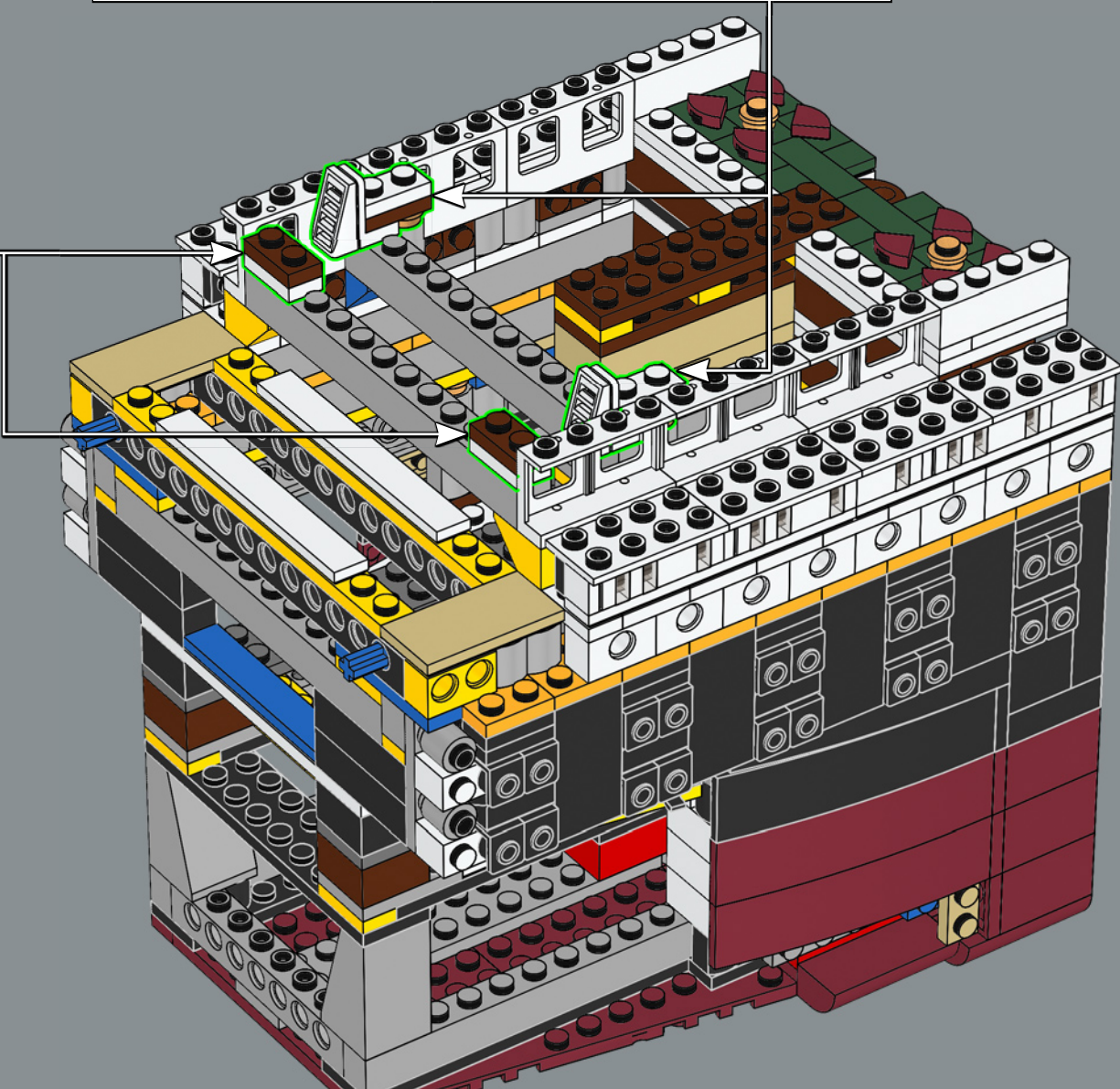
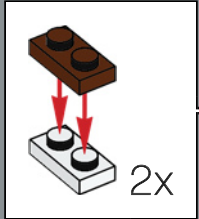
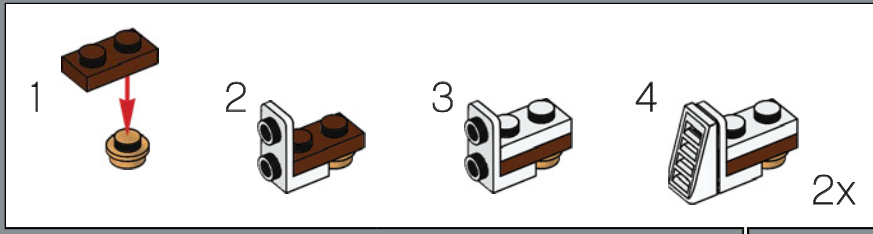



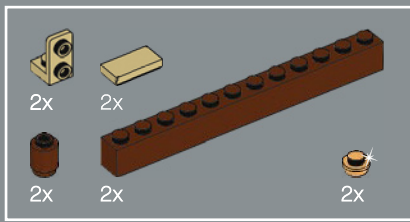

236

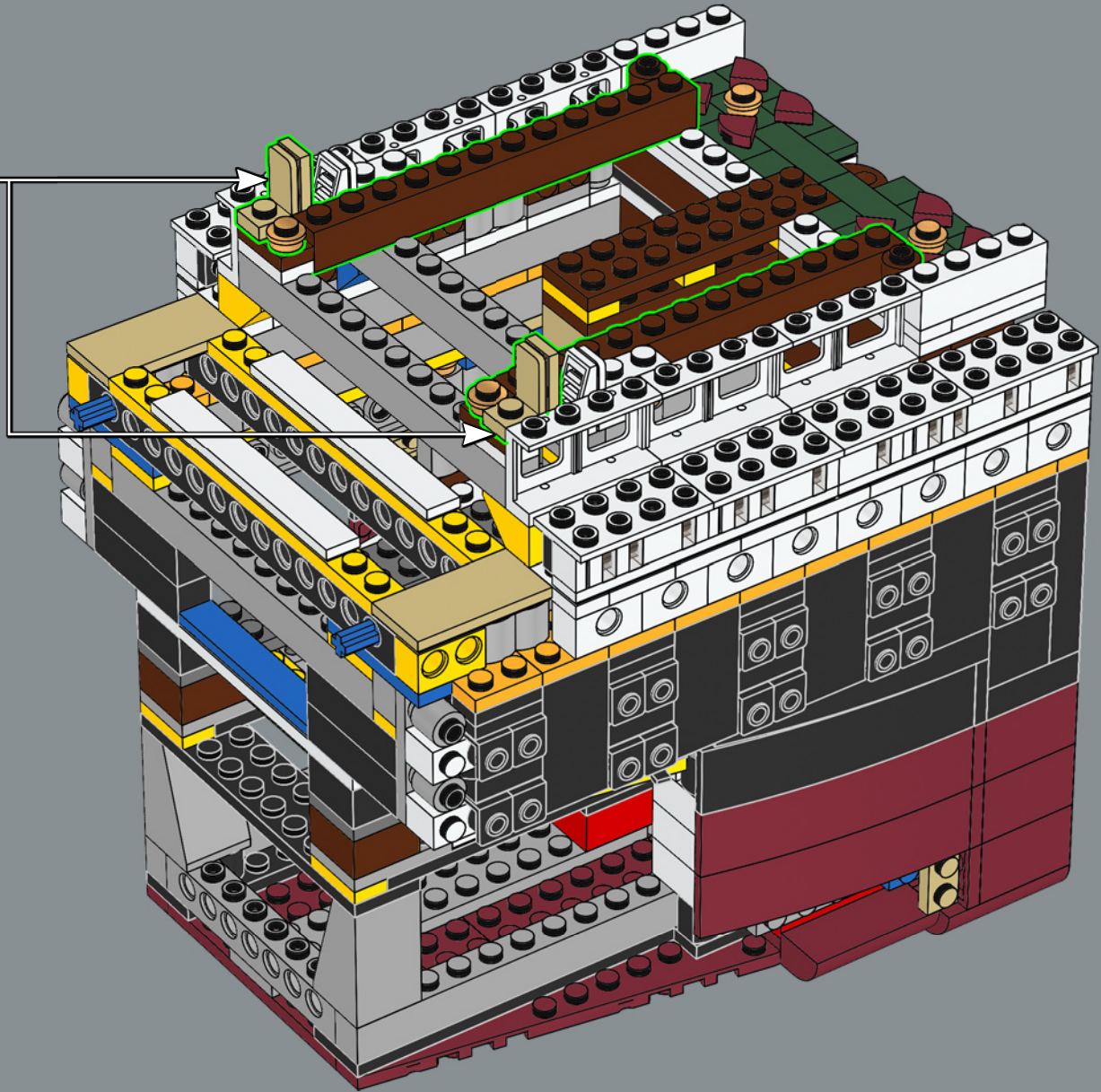
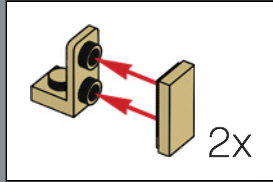

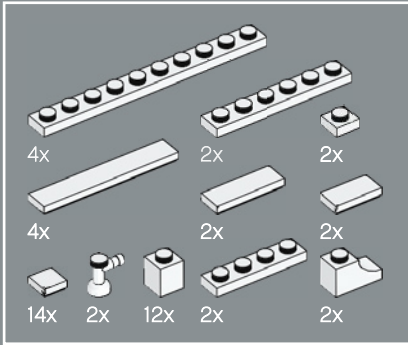
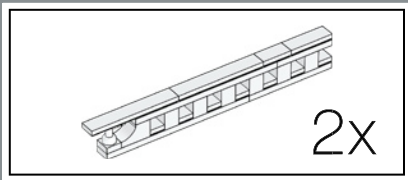

237

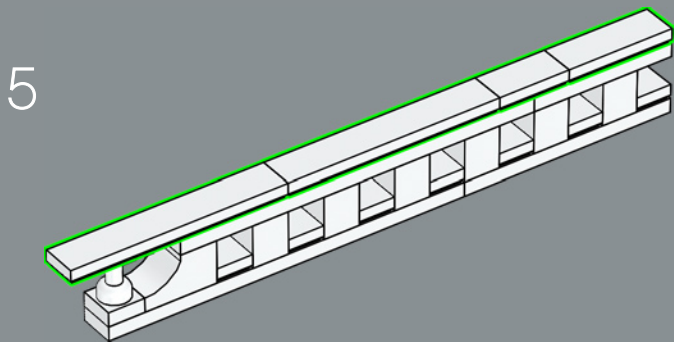
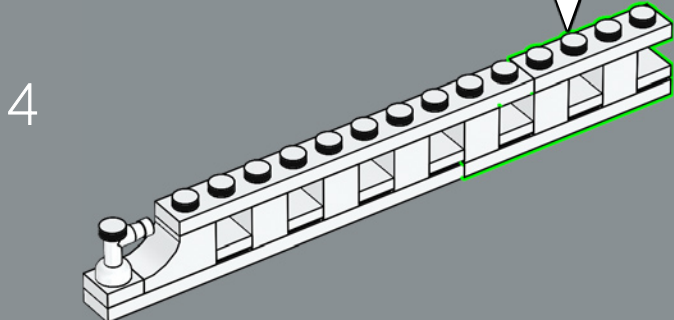
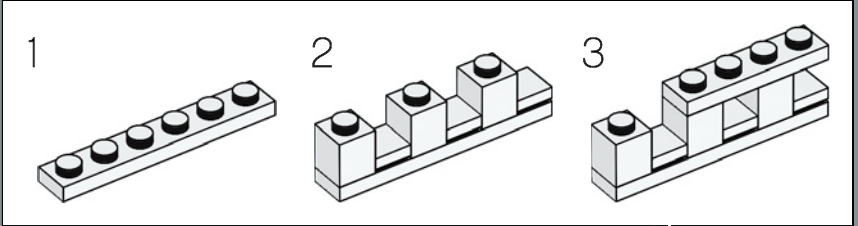
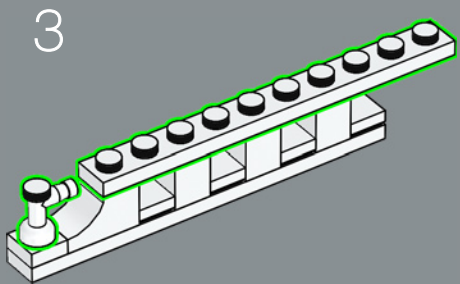
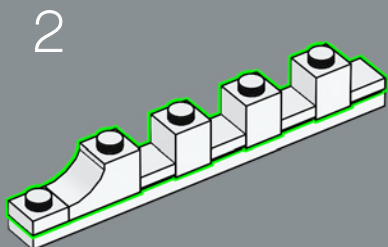
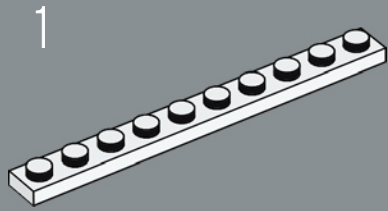

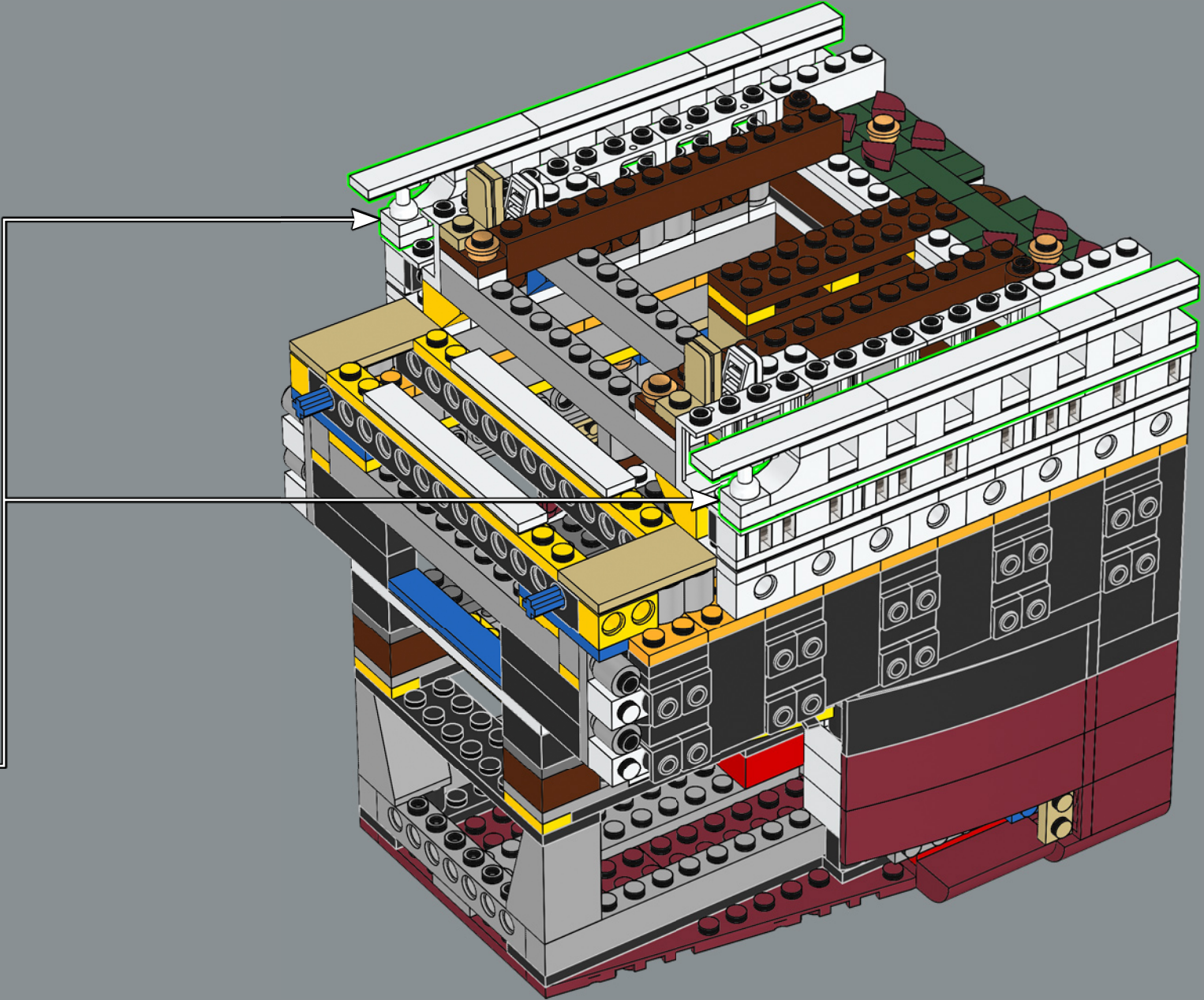

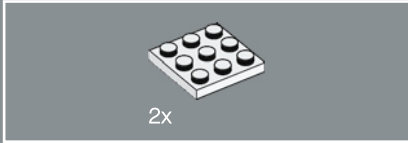
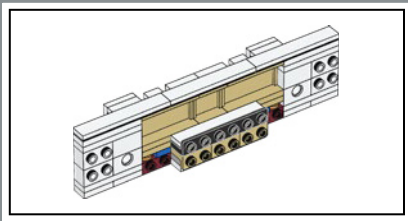

238

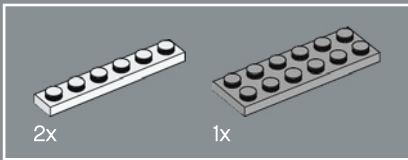
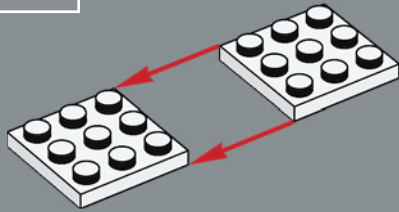

239

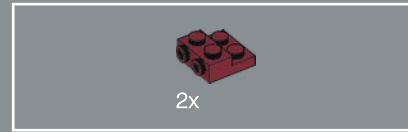
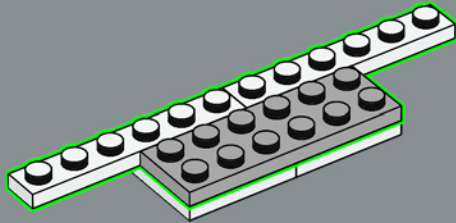

240

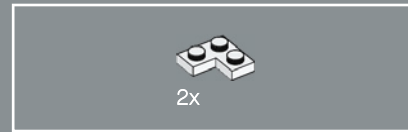
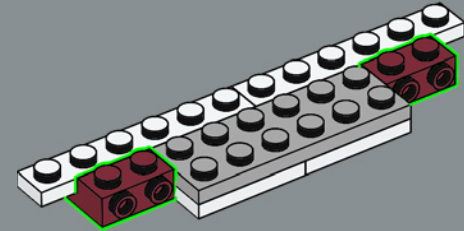

241

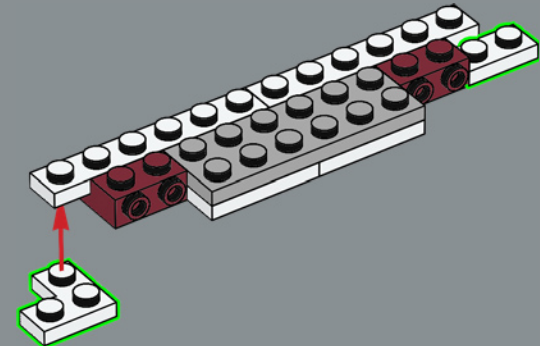

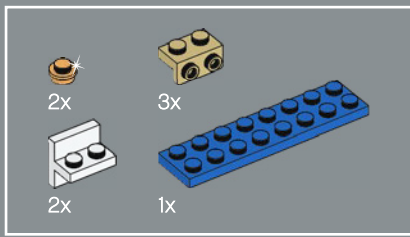

242

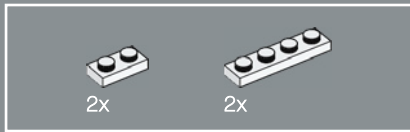
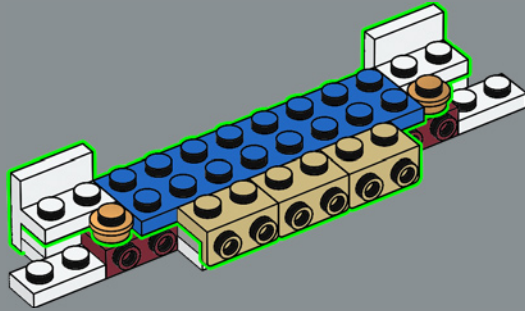

243

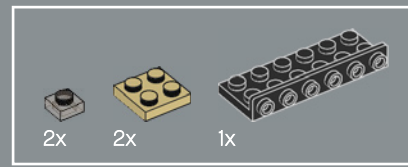
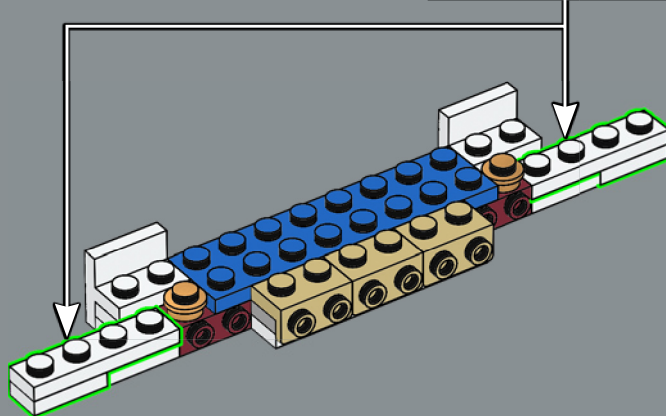
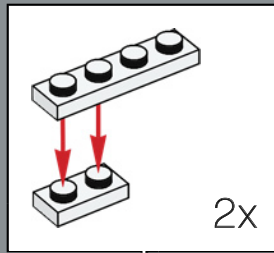

244

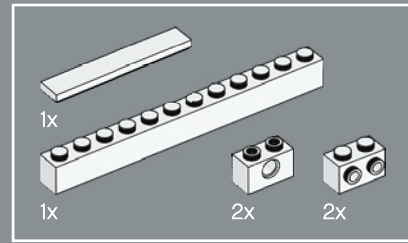
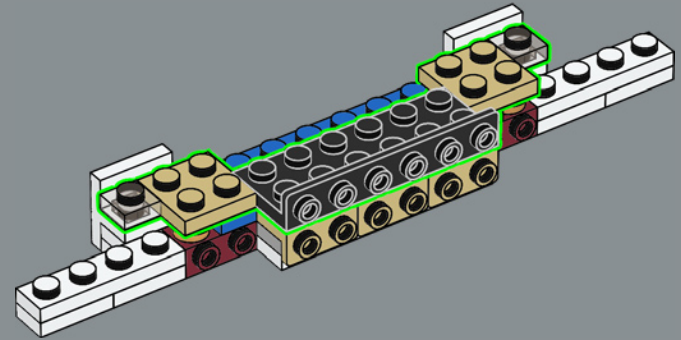

245

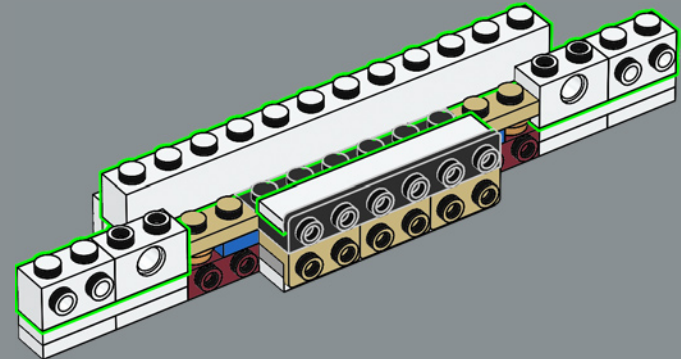

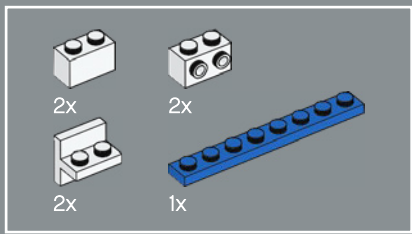

246

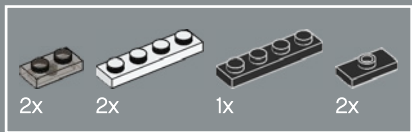
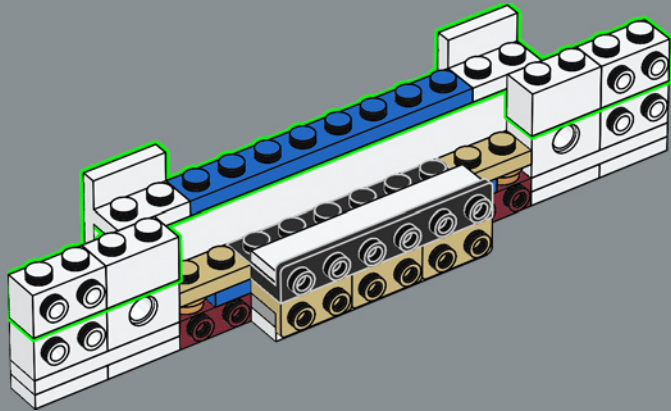

247

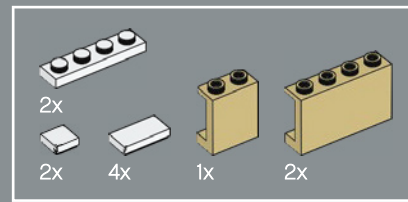
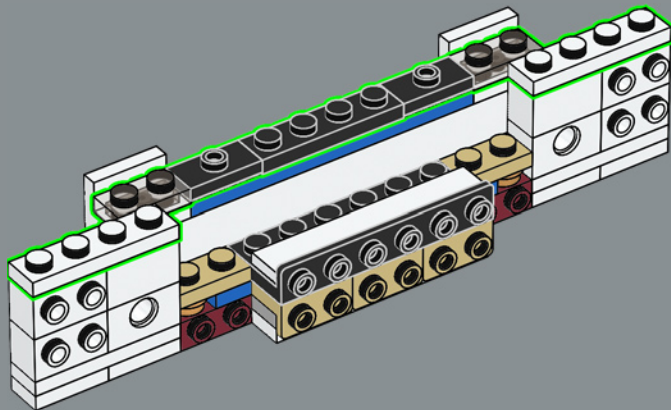

248

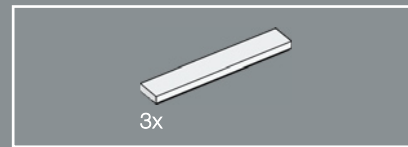
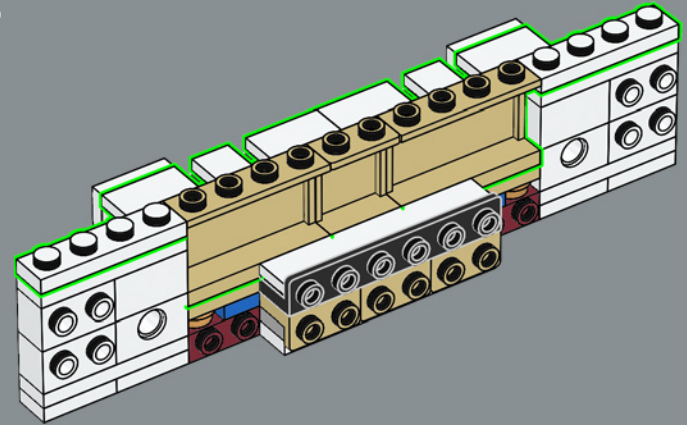

249

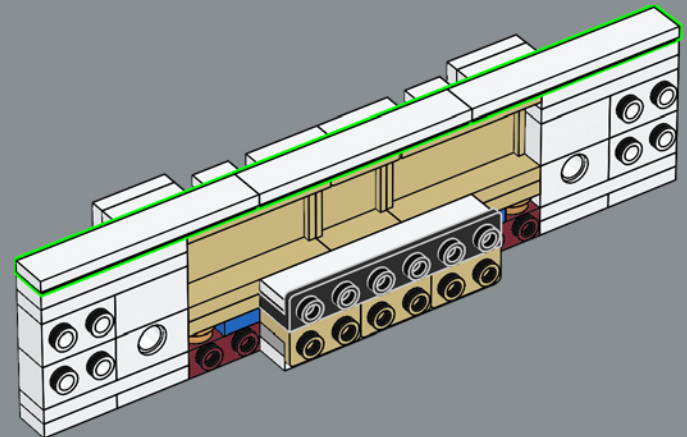

250

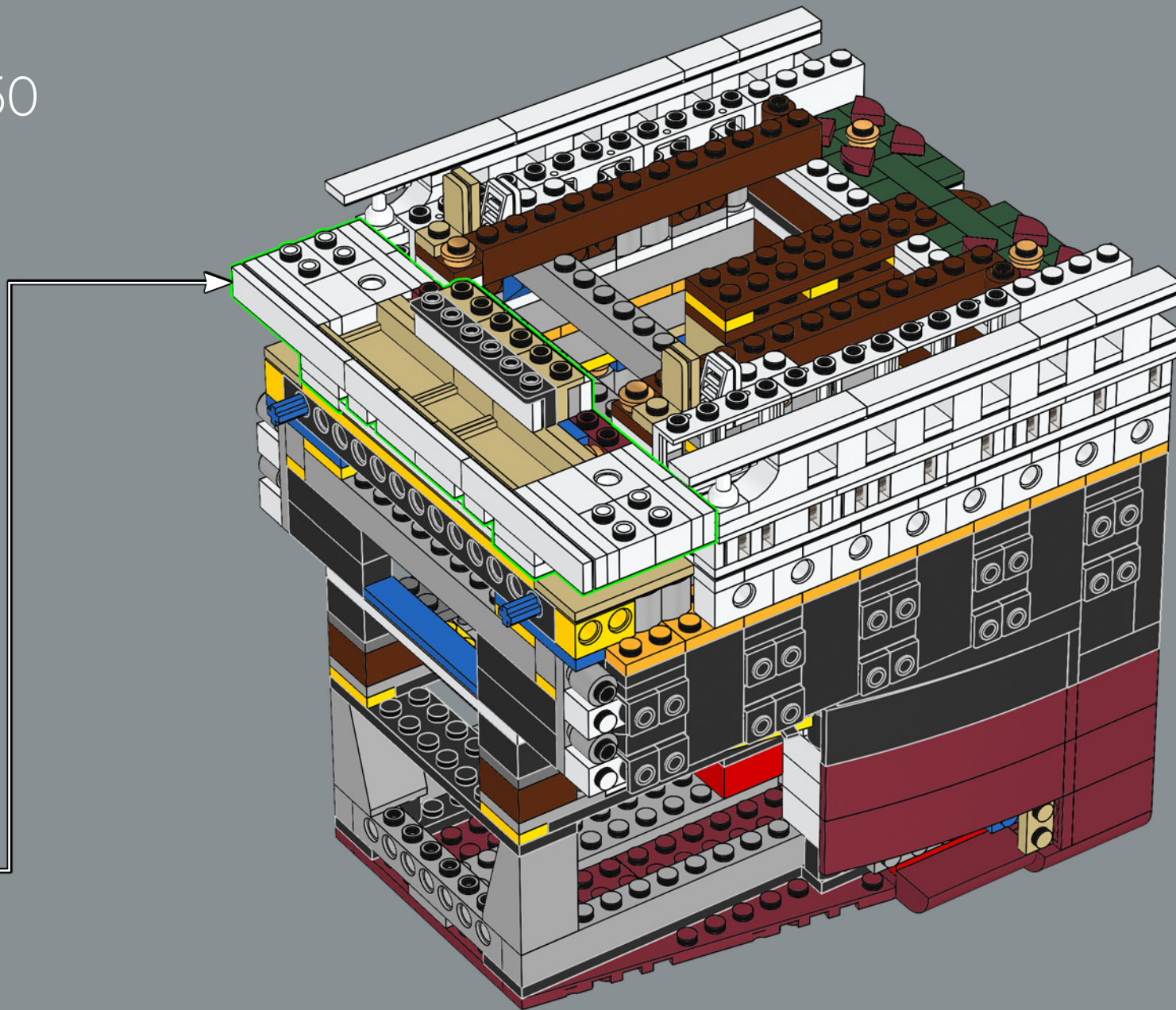

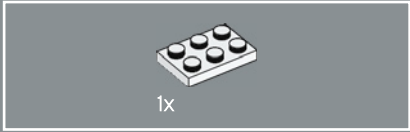
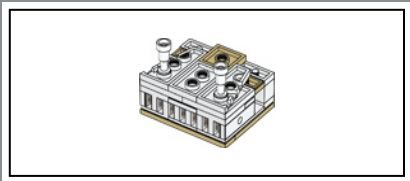

251

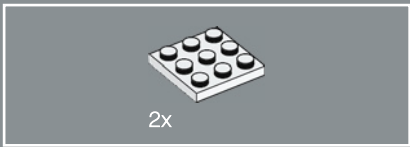

252

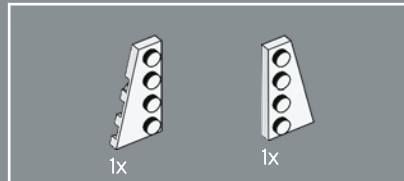
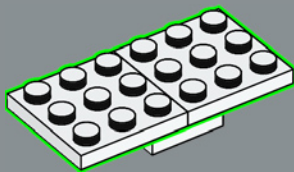

253

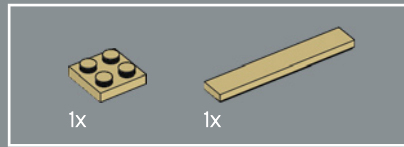
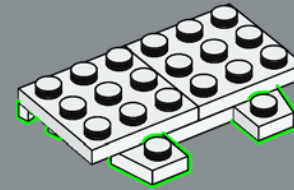

254

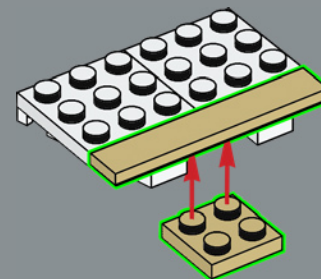



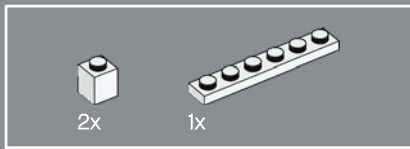

255

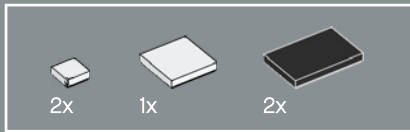
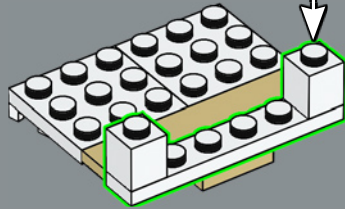
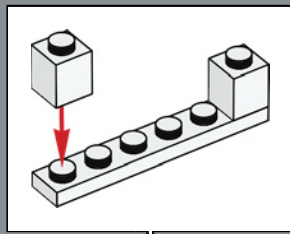

256

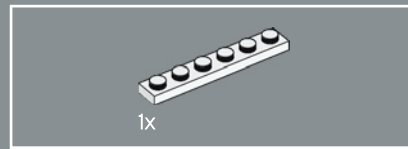
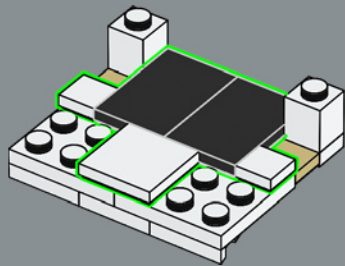

257

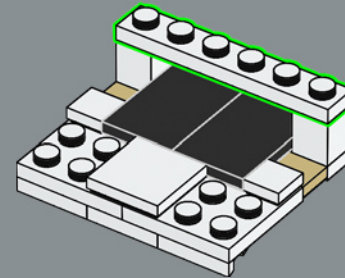

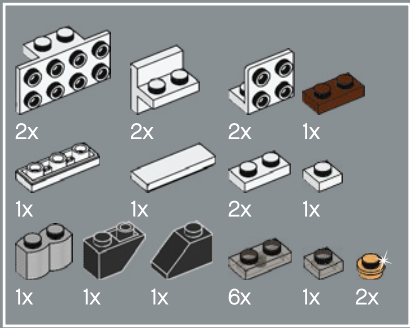

258

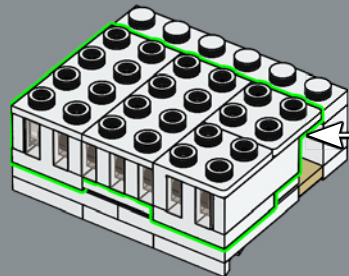
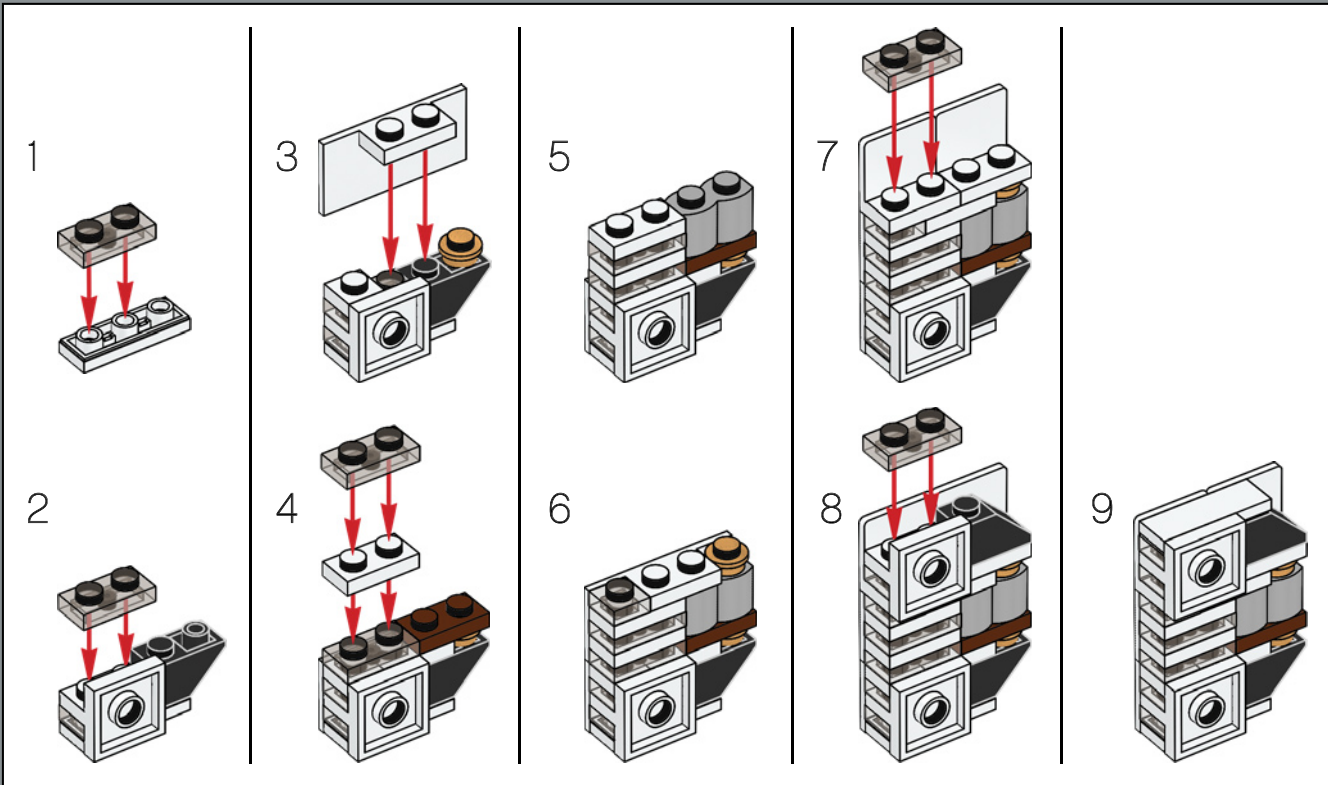

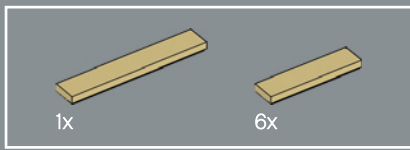

259

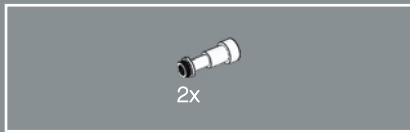
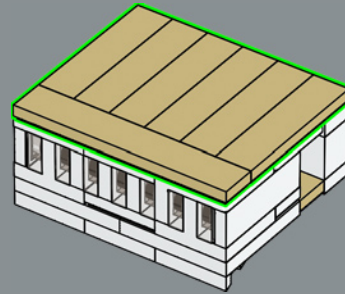

260

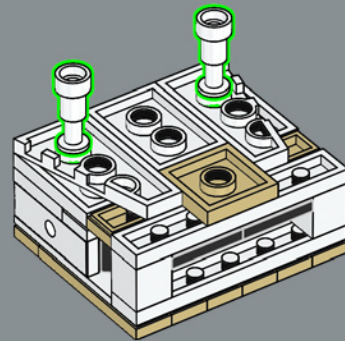

Die Brücke befand sich 2,4 Meter über dem Deck und erstreckte sich über die ganze Breite des Schiffes, um das An- und Ablegen des Schiffes überwachen zu können.

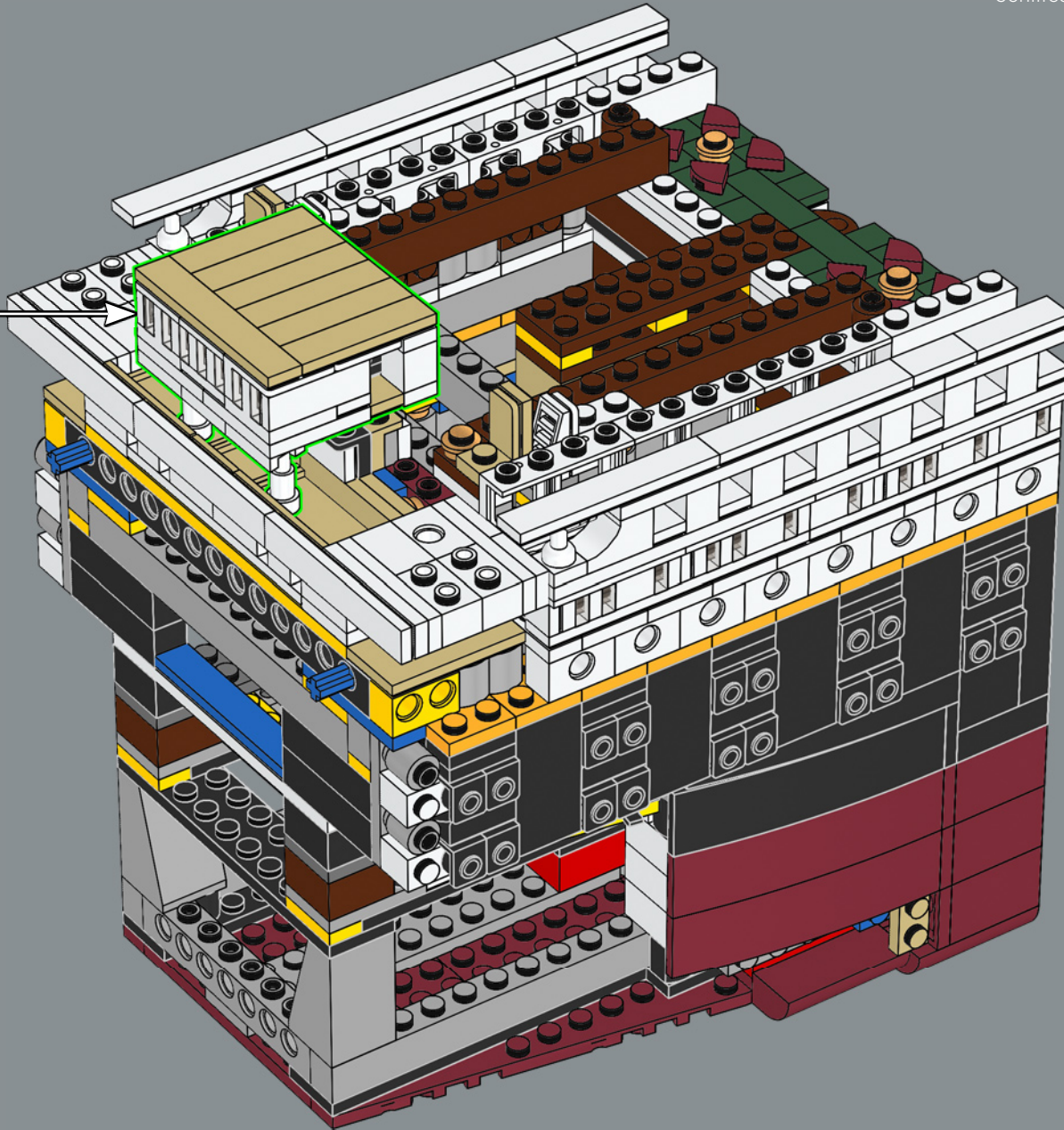



262

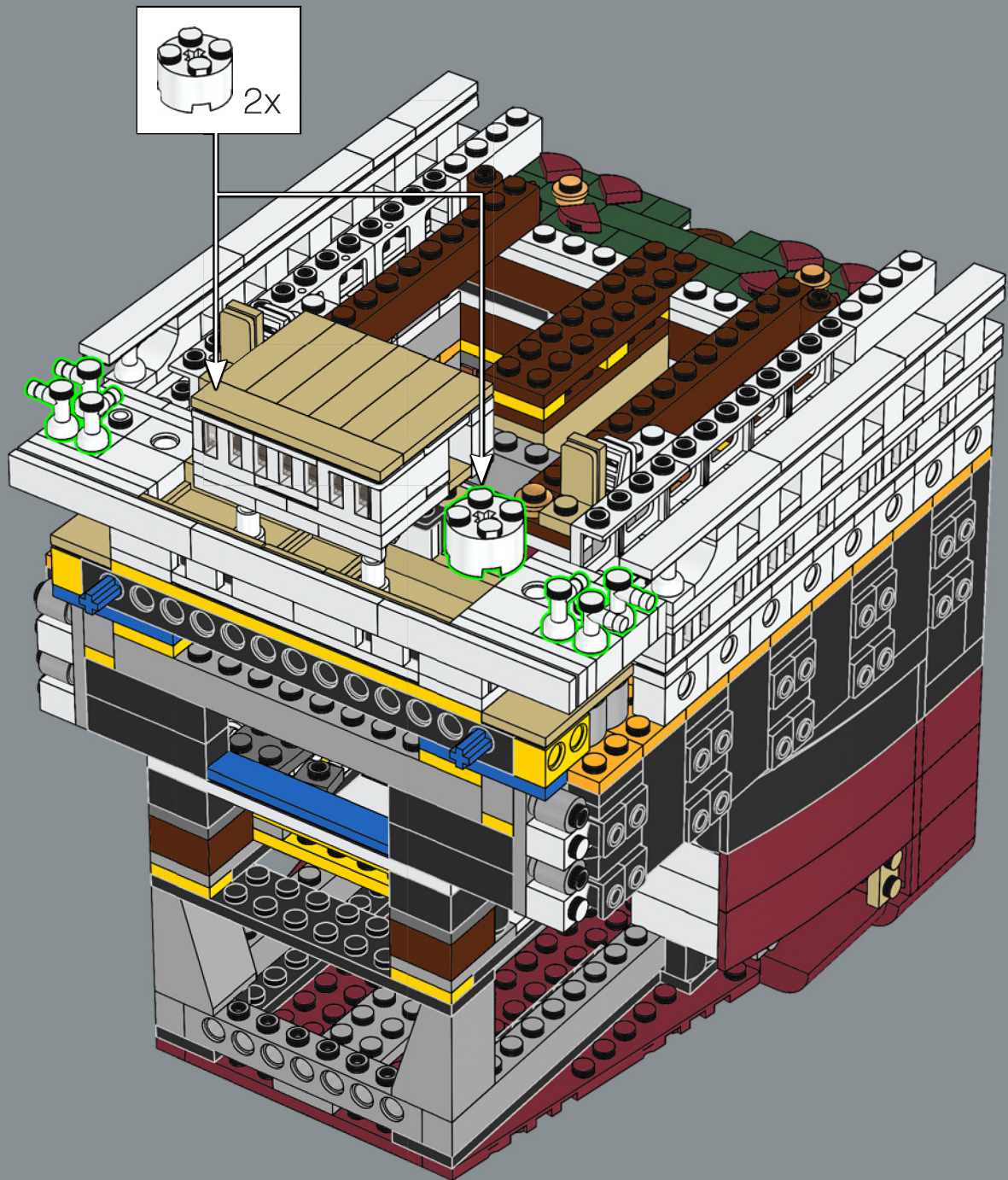

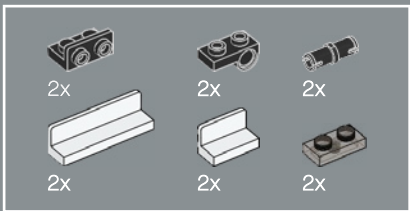

263

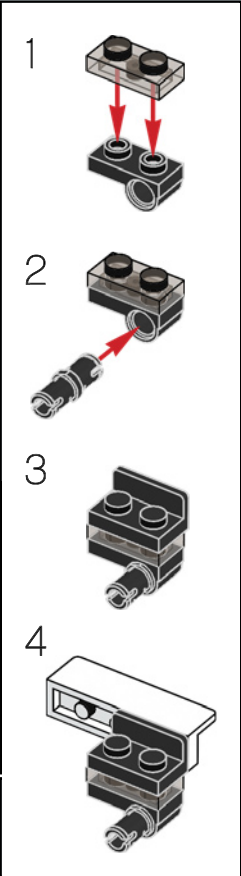
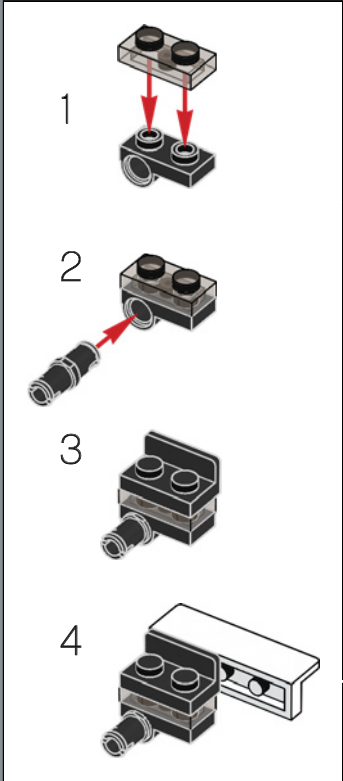

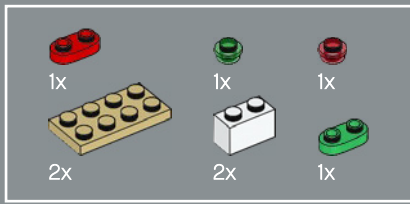

264

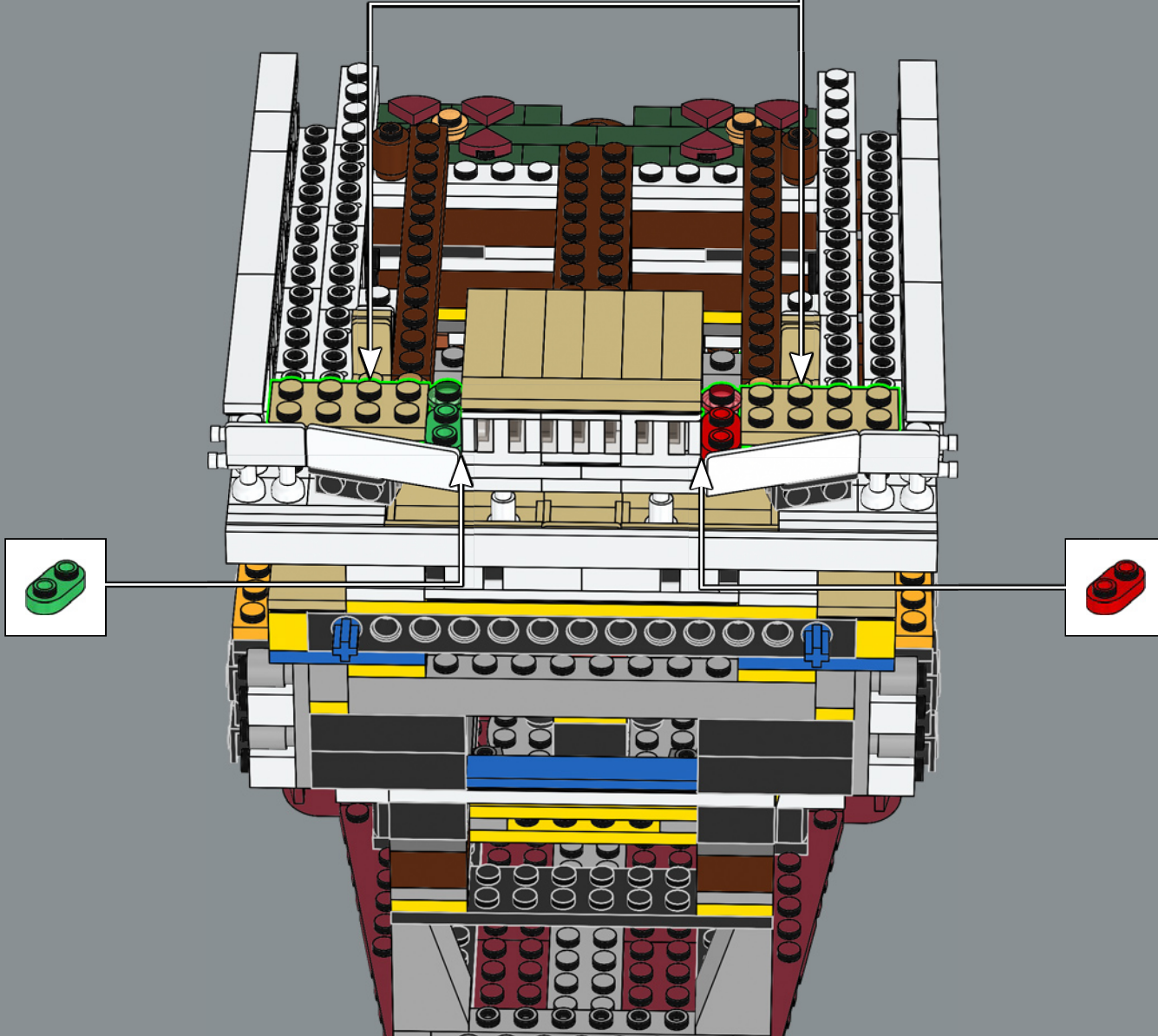
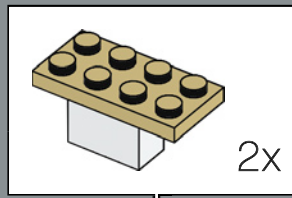

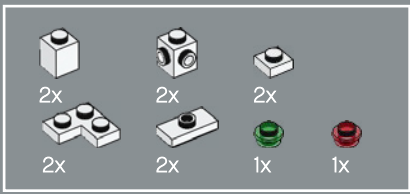

265

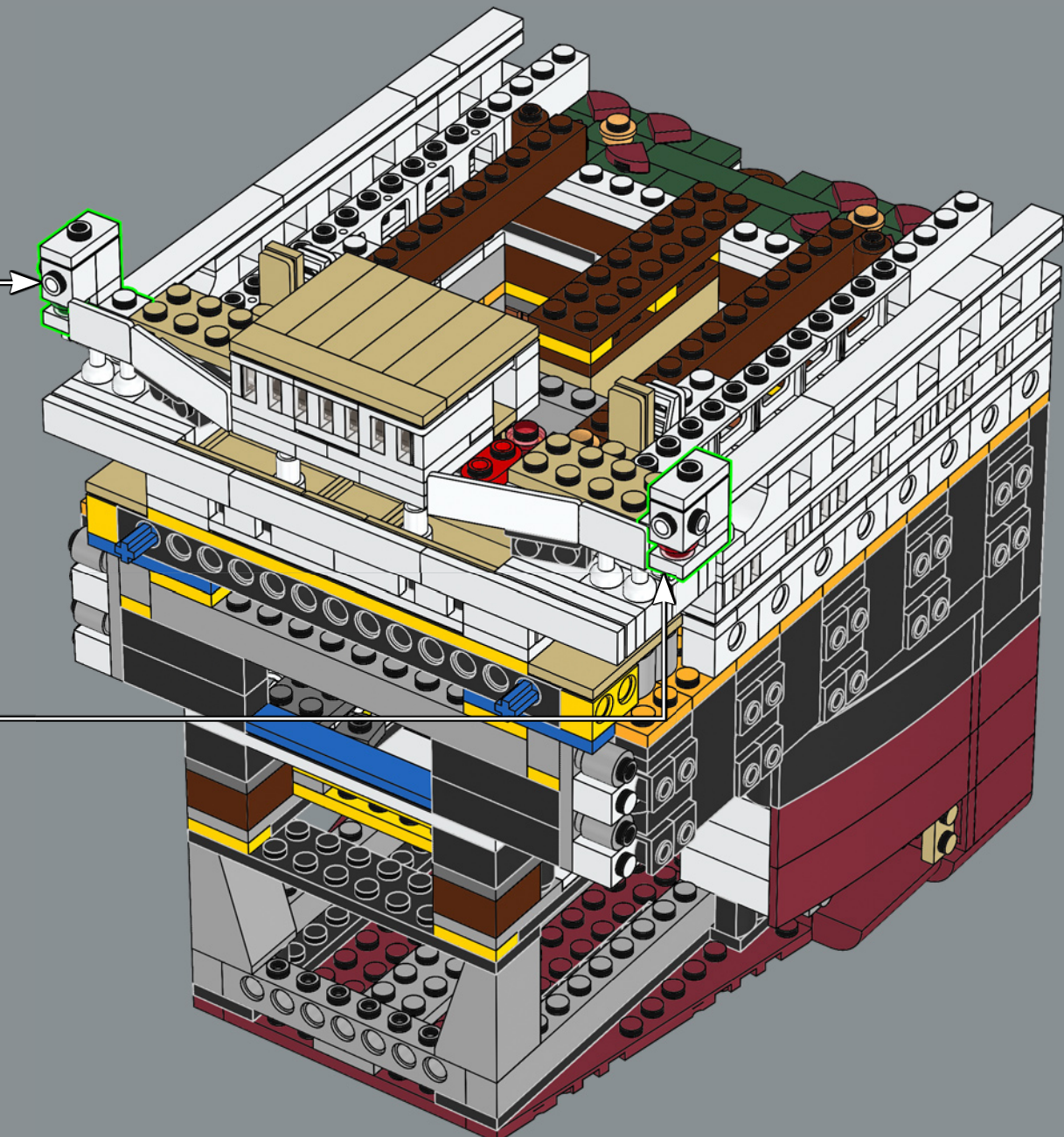
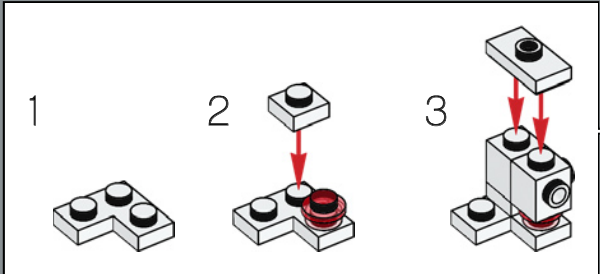
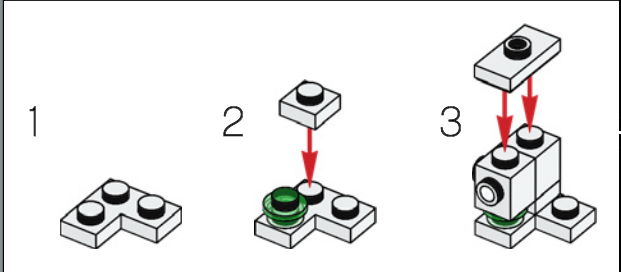



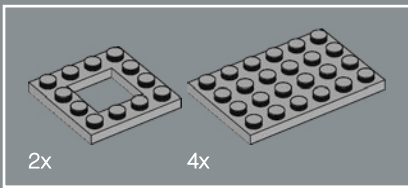

266

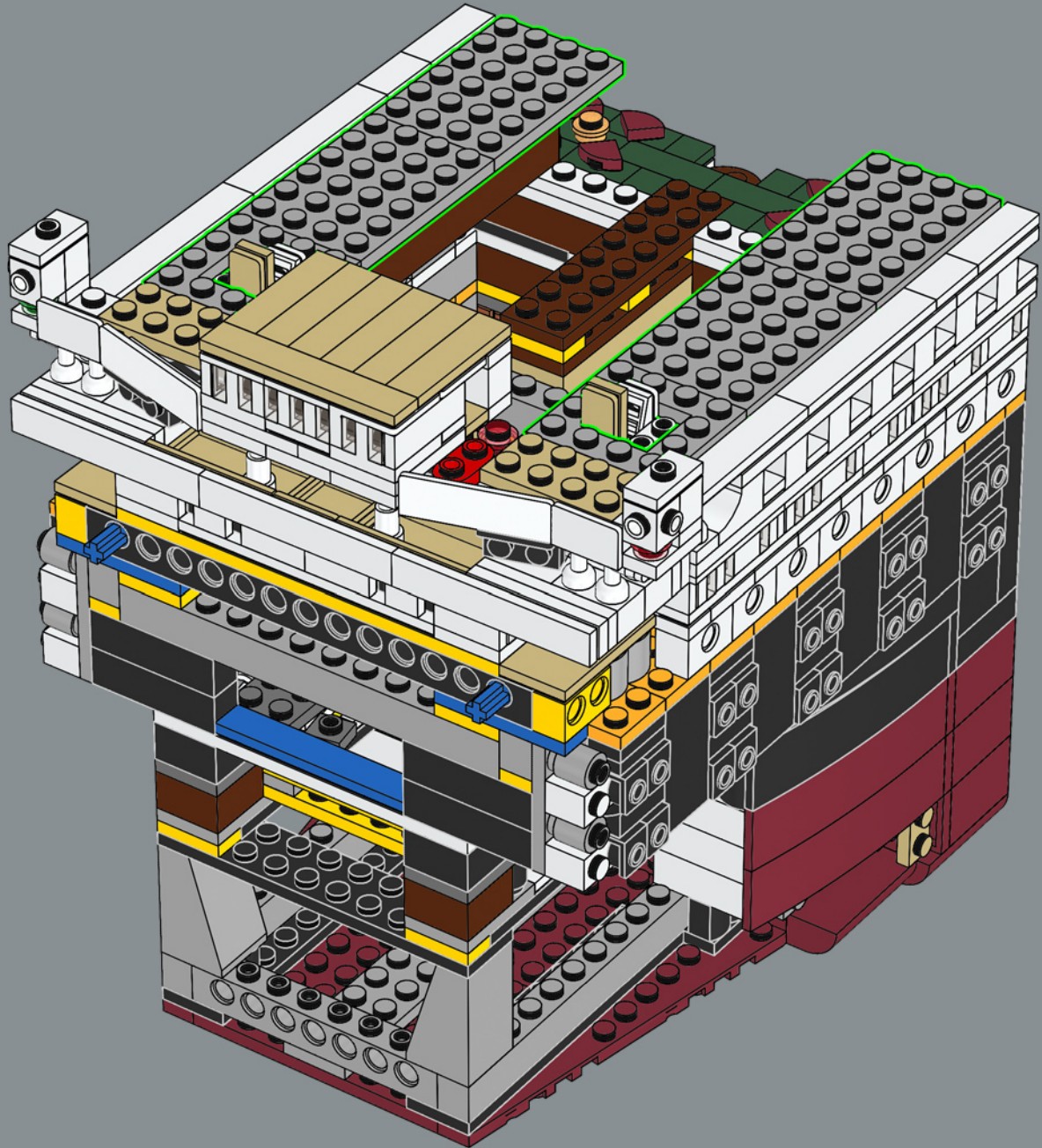

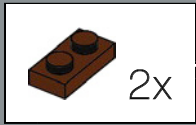
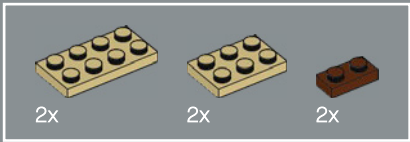

267

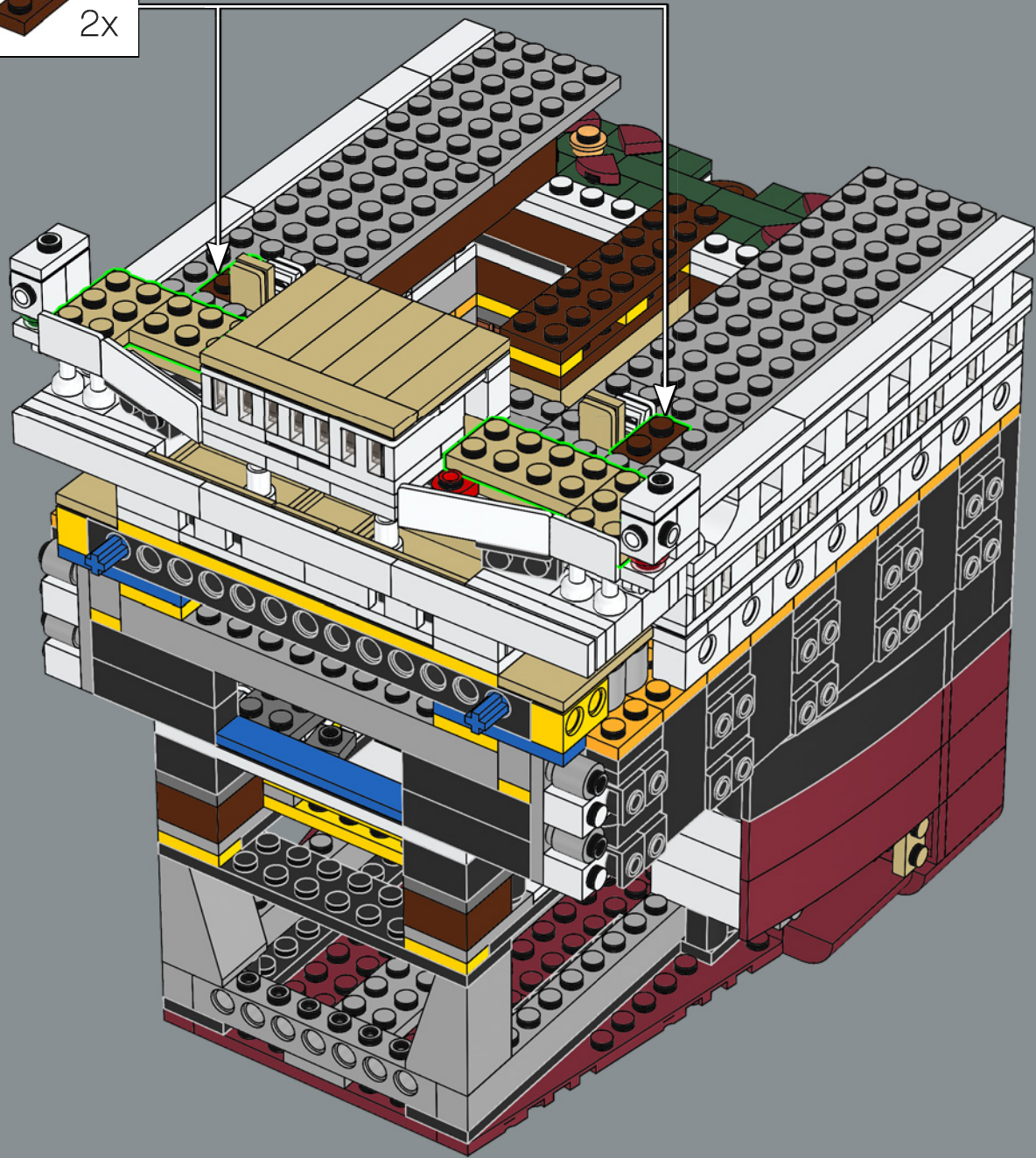

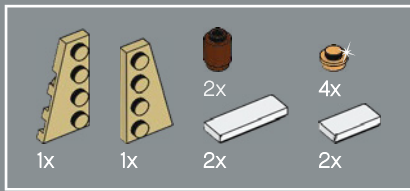

268

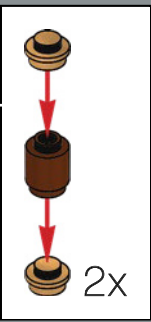
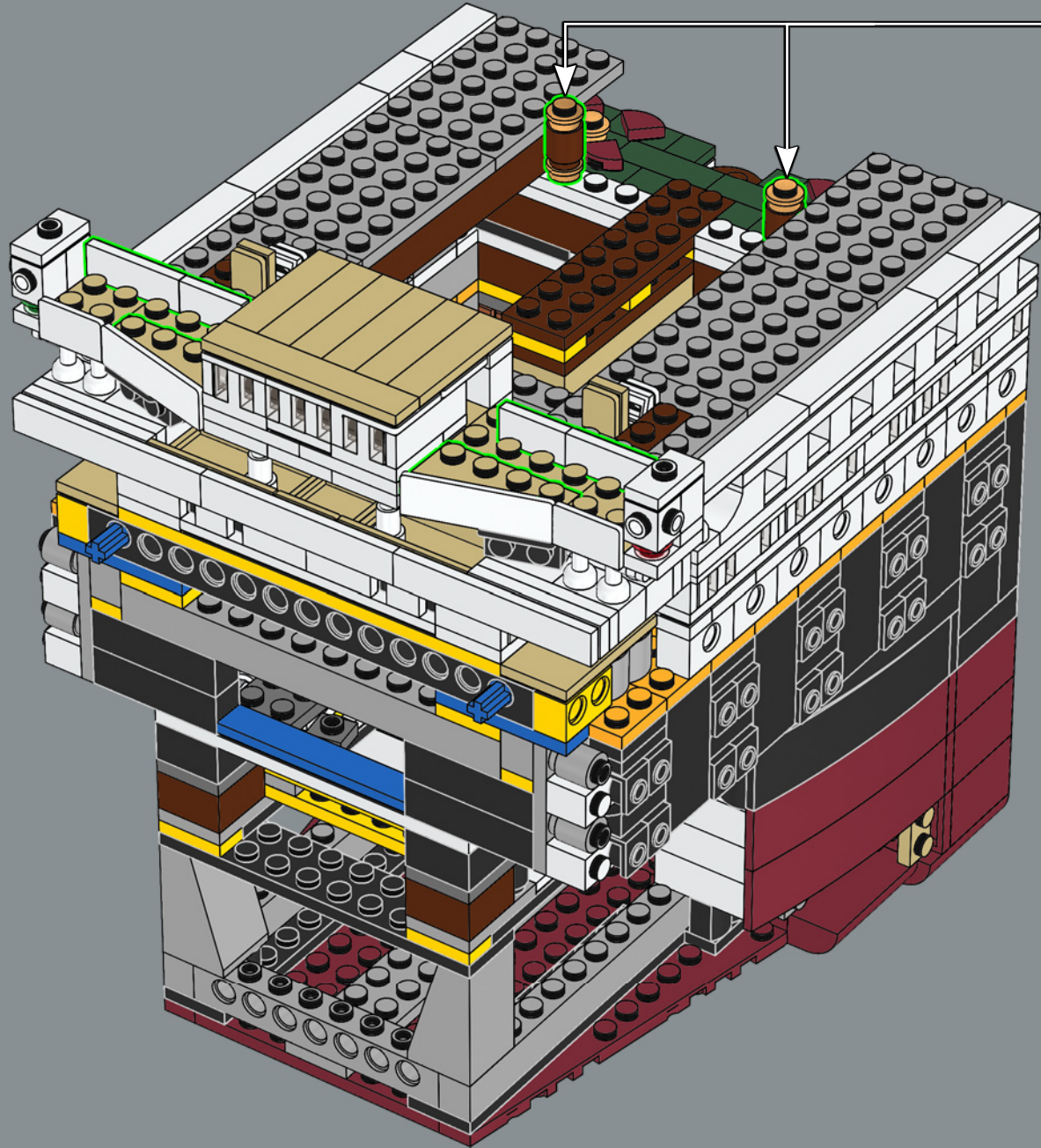
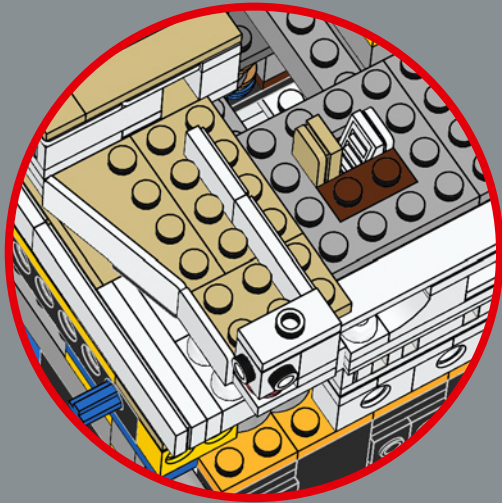
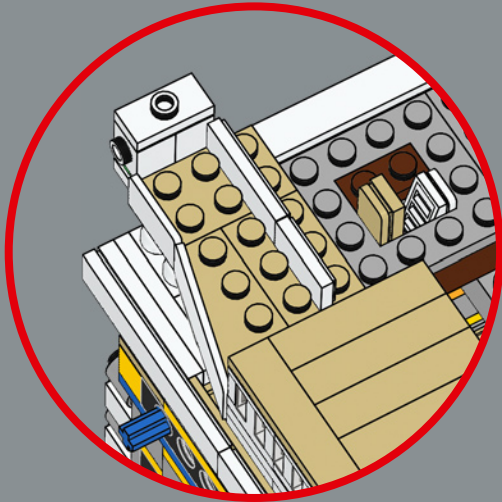

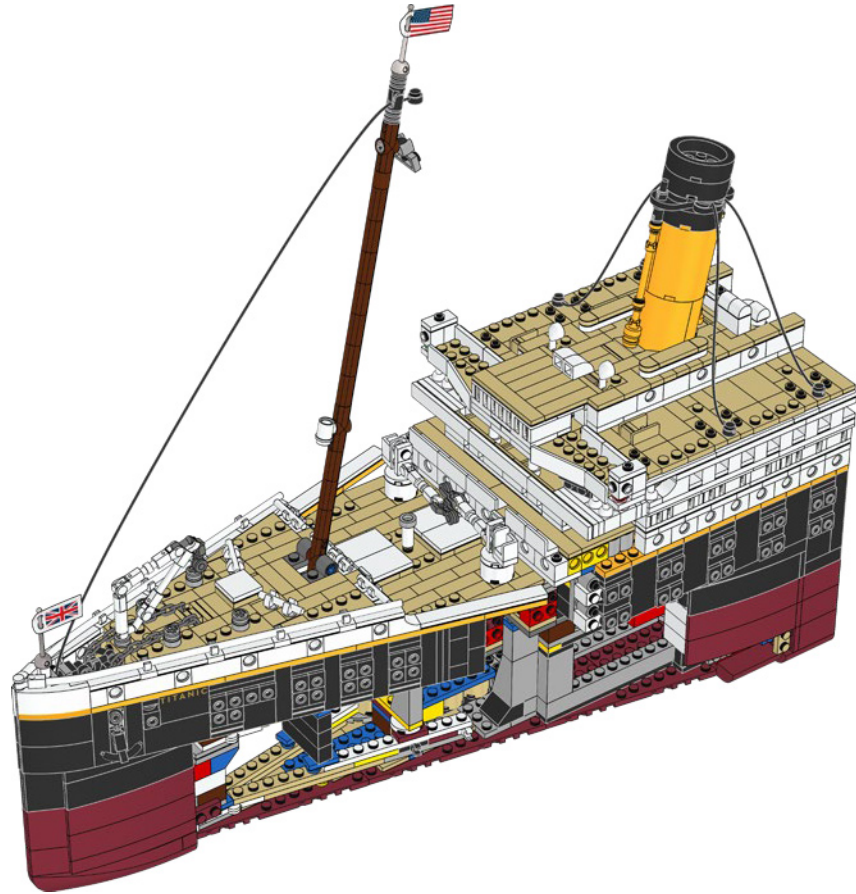
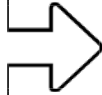

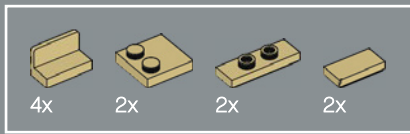

269

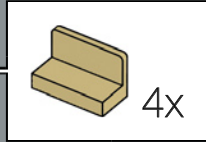
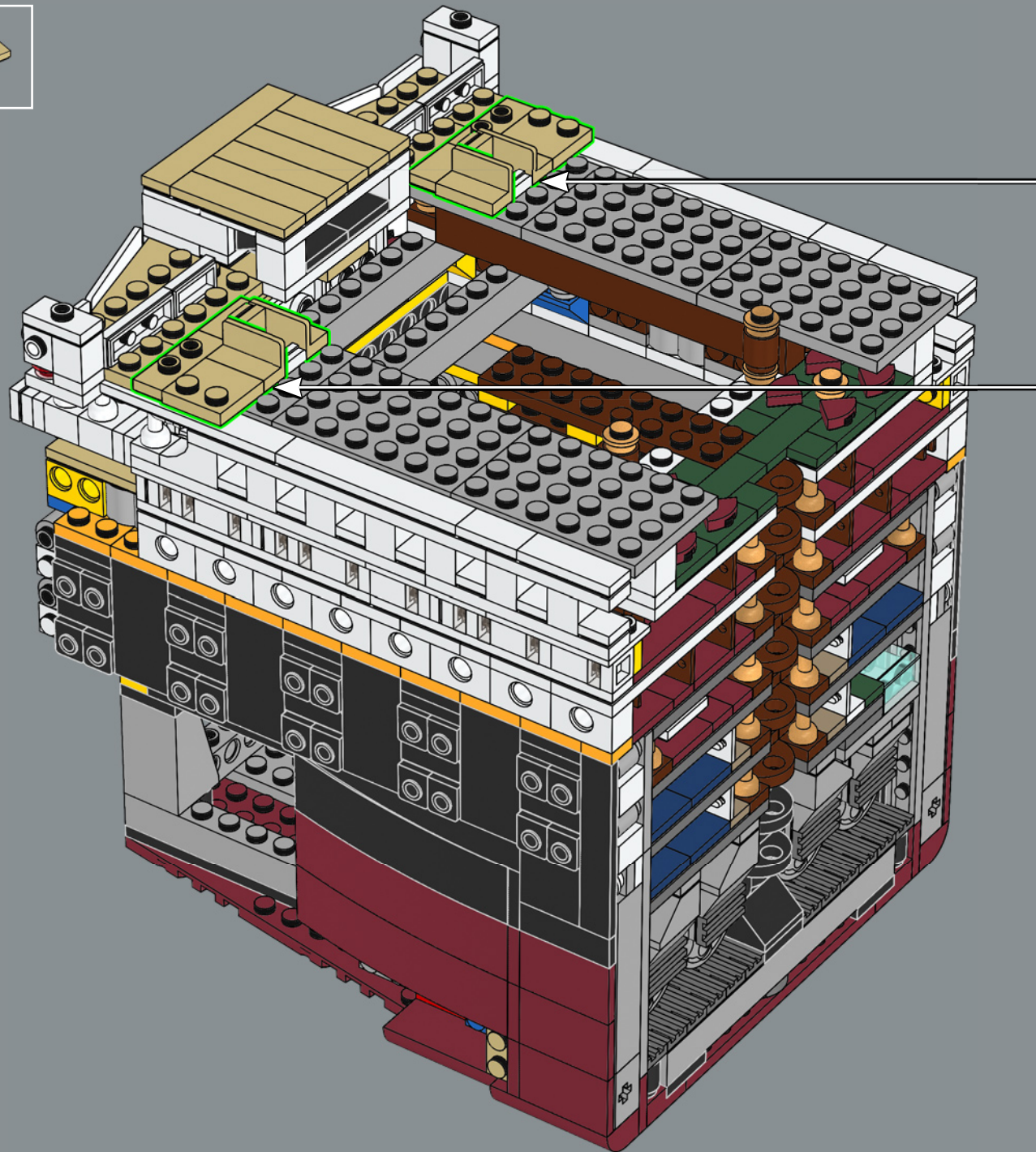

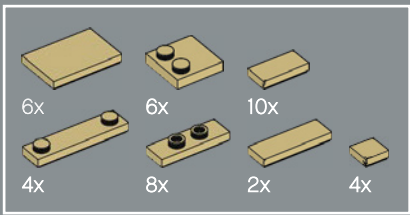

270

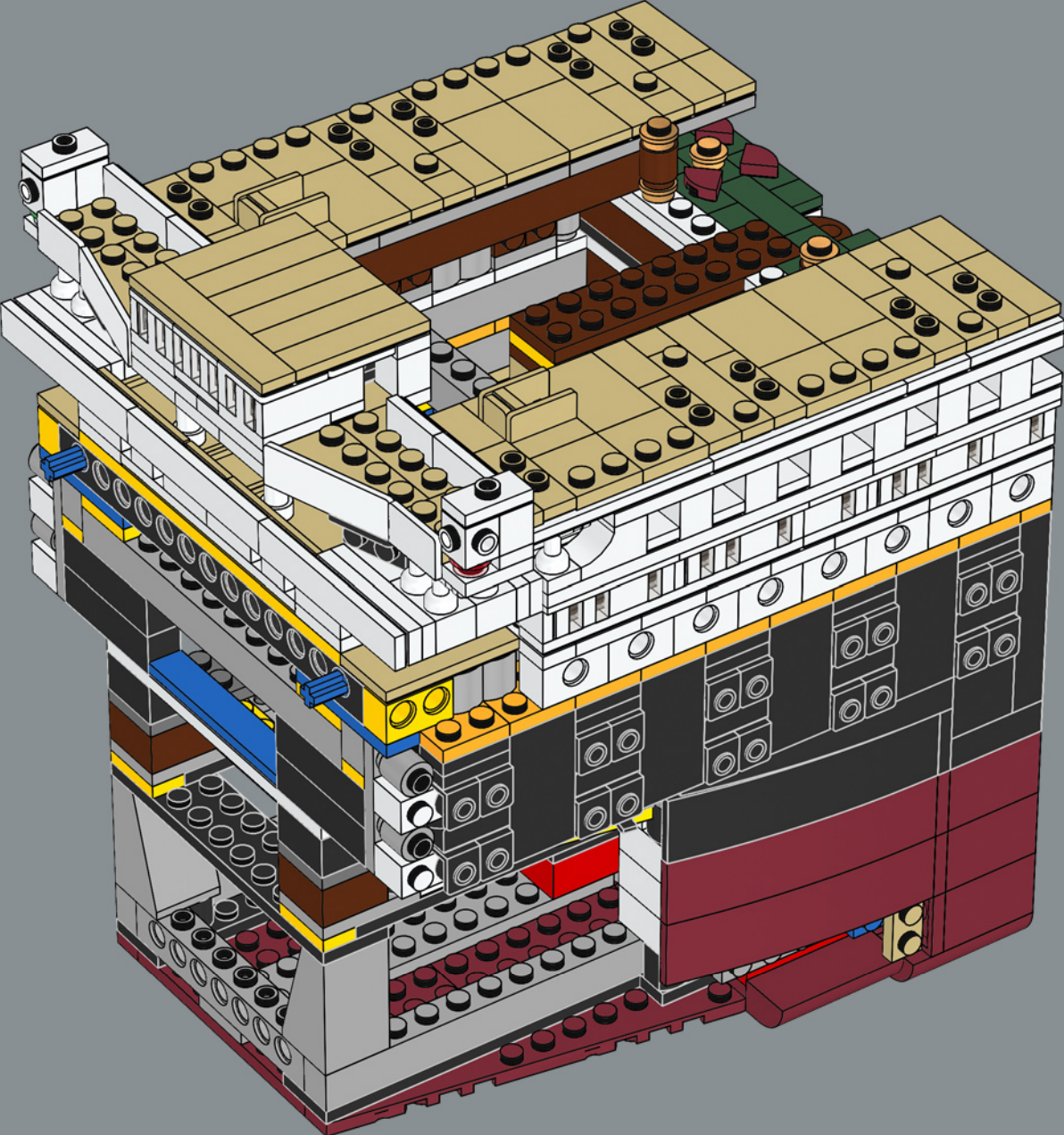



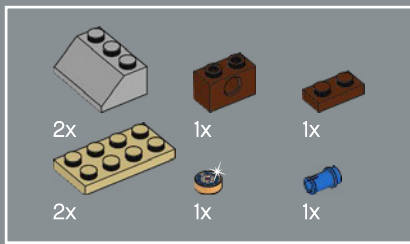

274

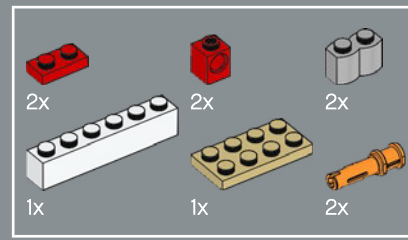
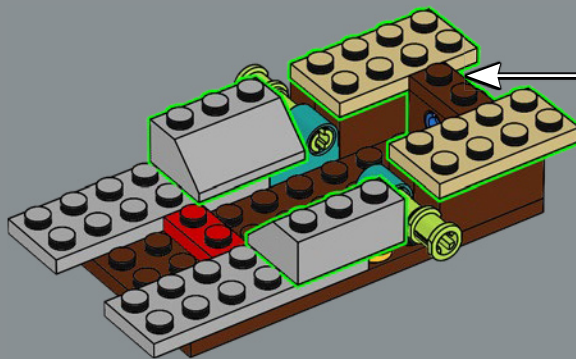
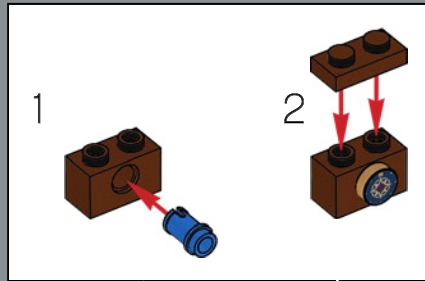

275

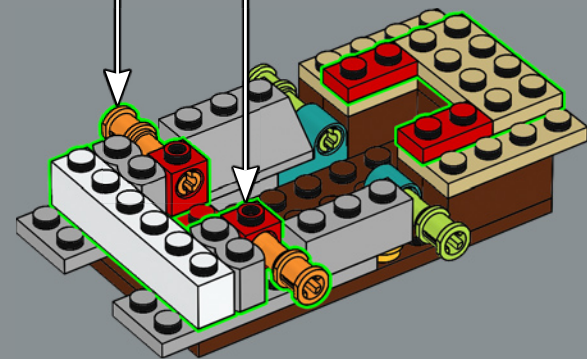
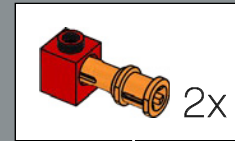



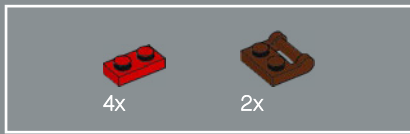

276

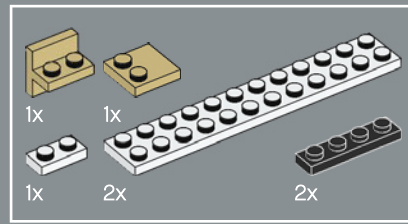
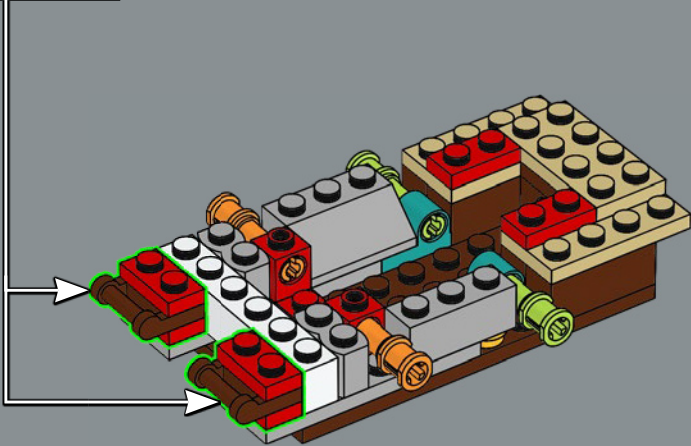
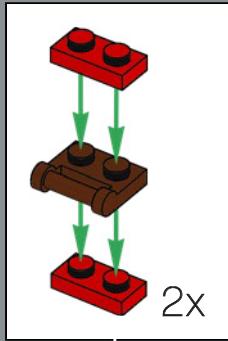

277

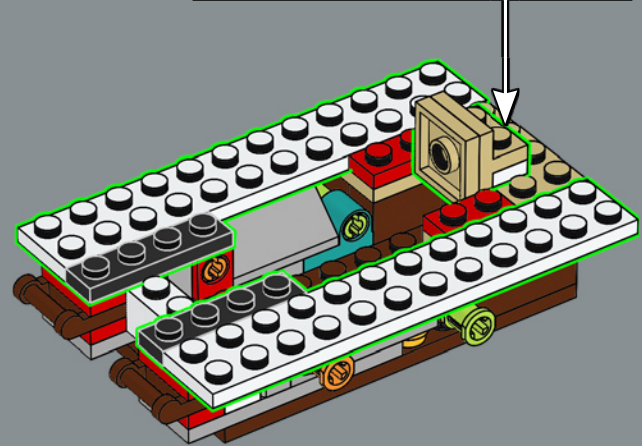
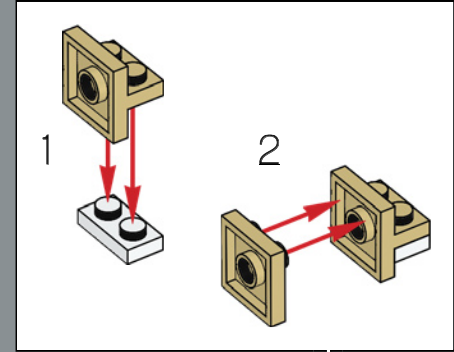

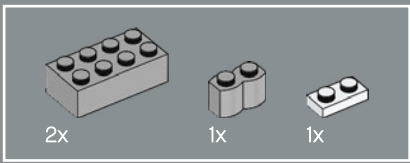

278

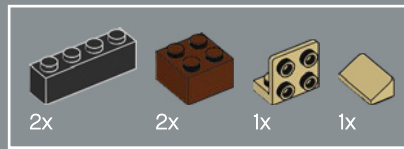
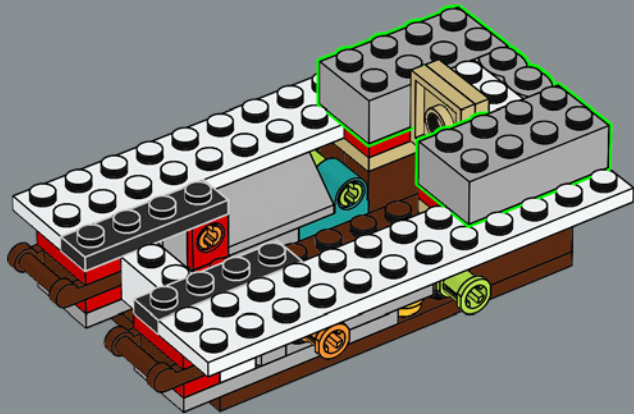

279

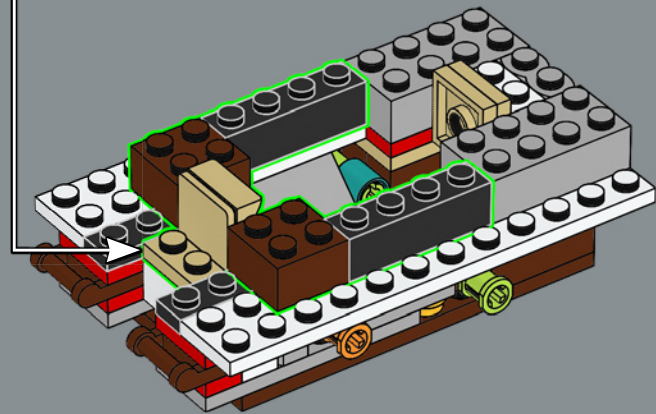
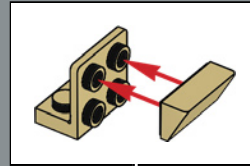

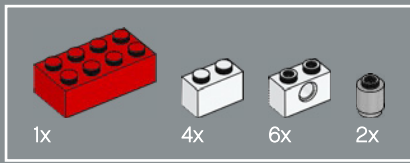

280

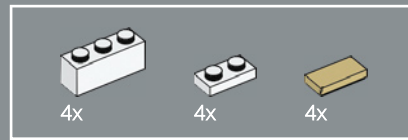
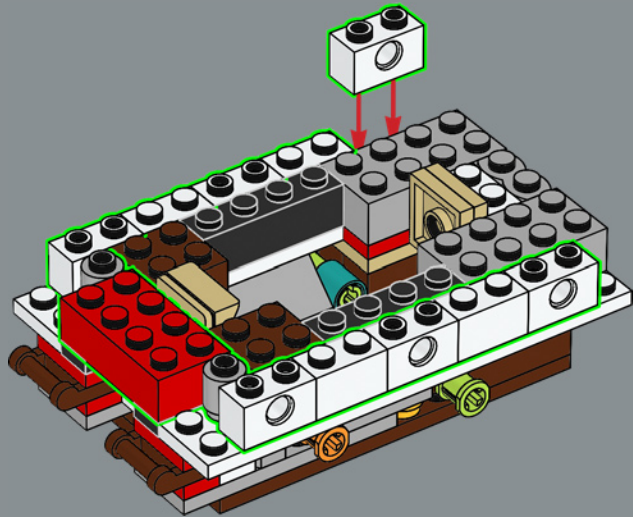

281

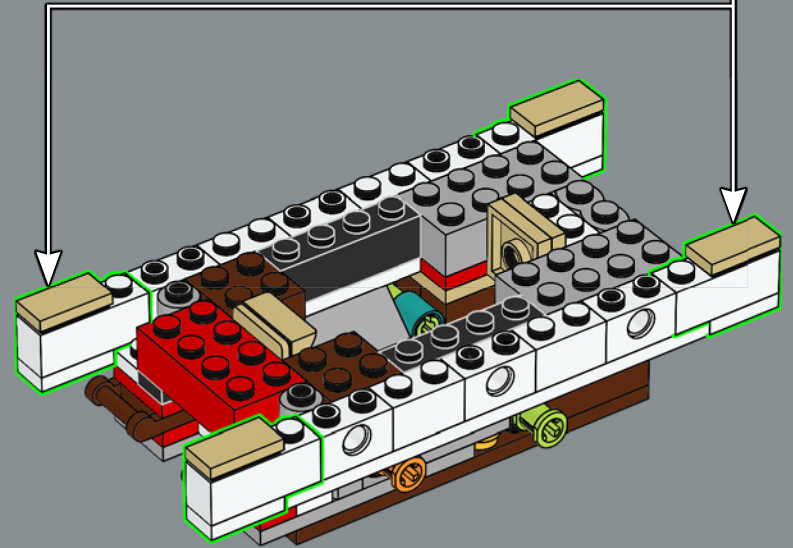
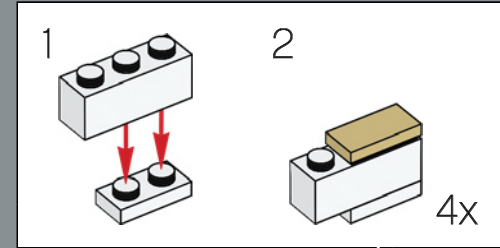

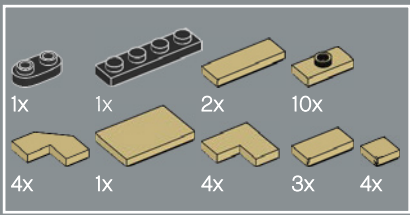

282

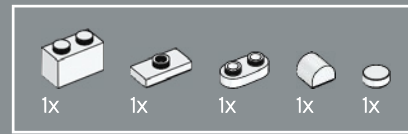
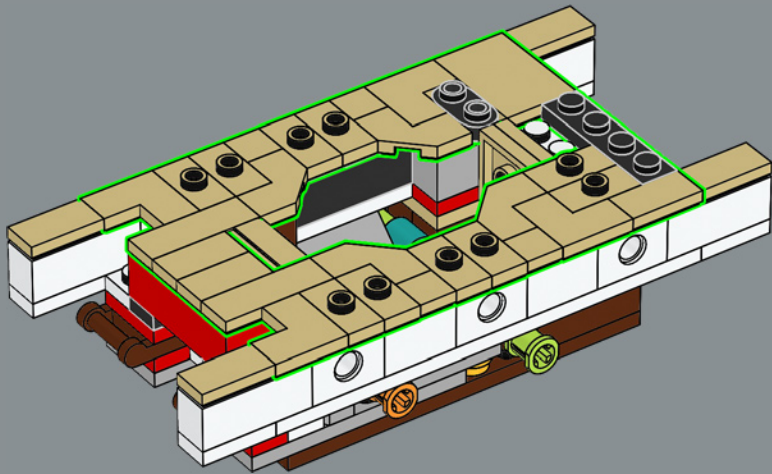

283

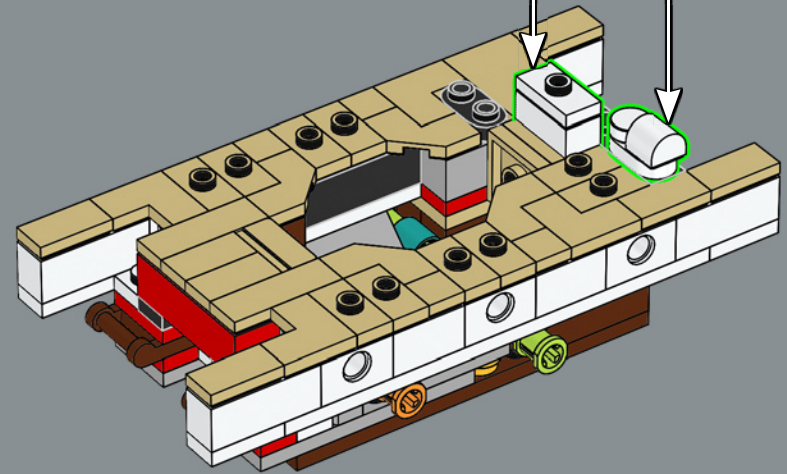
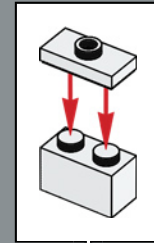
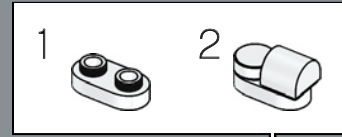

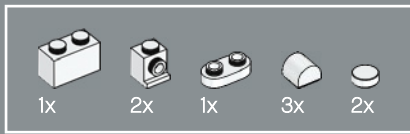

284

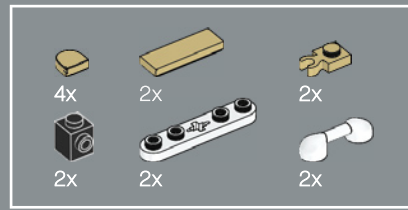
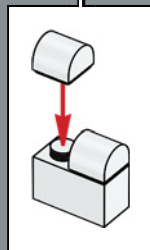
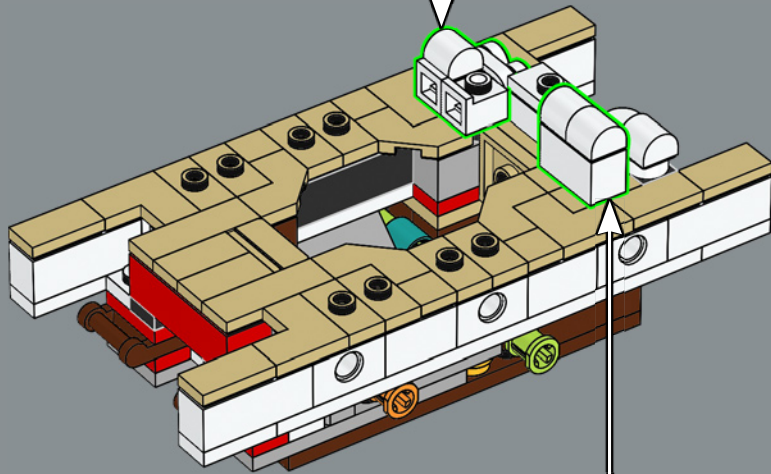
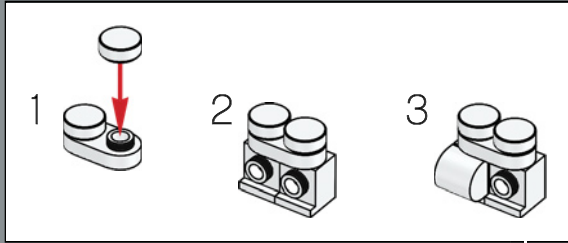

285

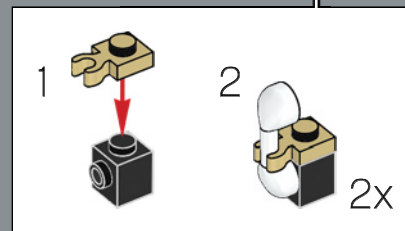
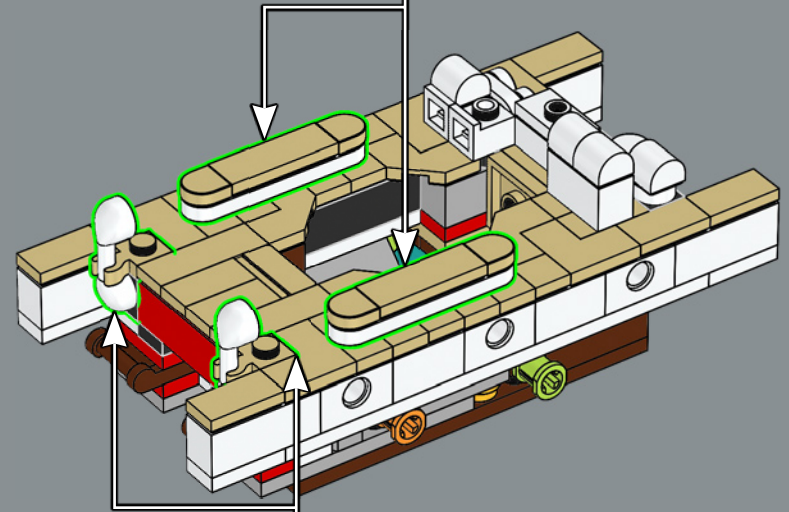
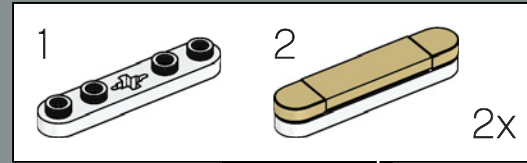

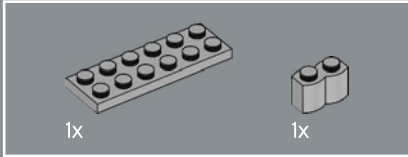
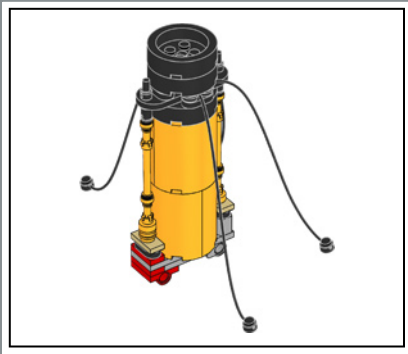

286

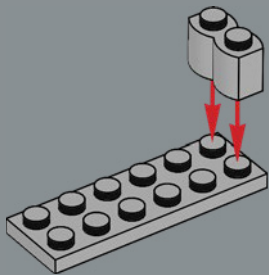

287

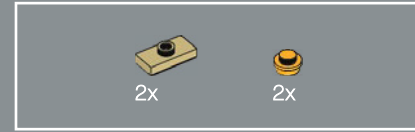
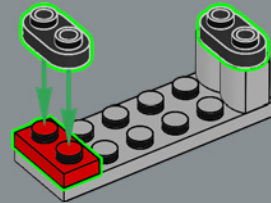

288

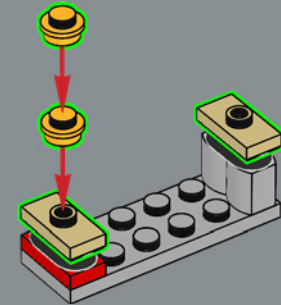

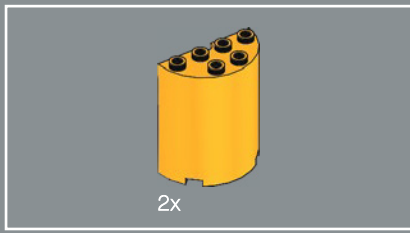

289

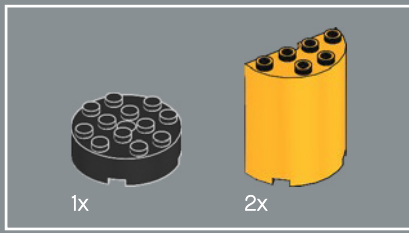
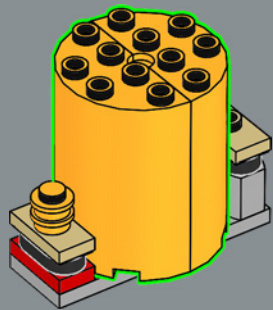

290

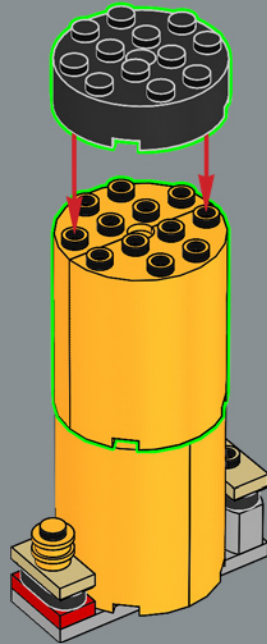

291

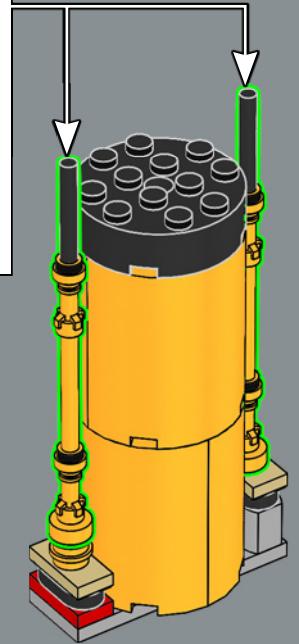
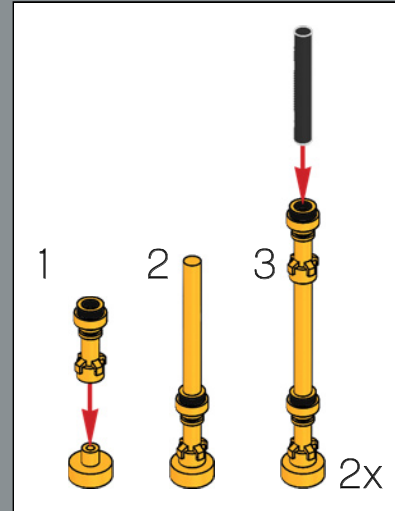

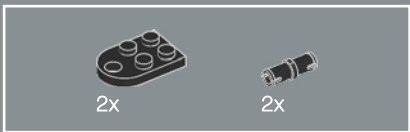

292

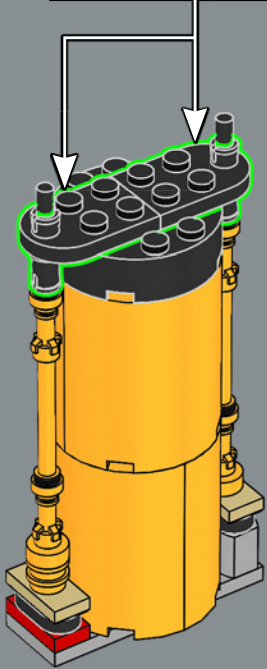
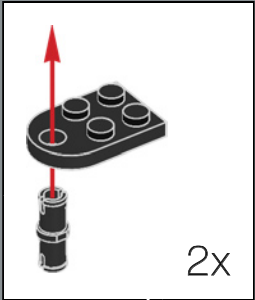

293

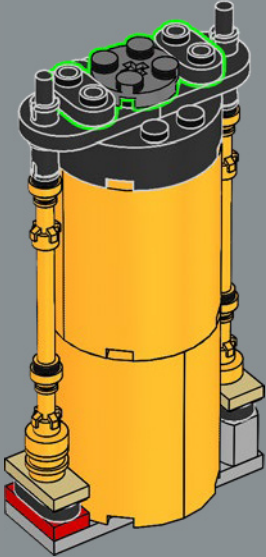



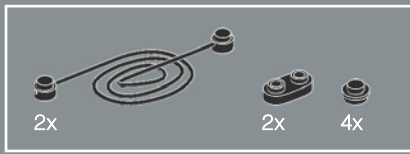

294

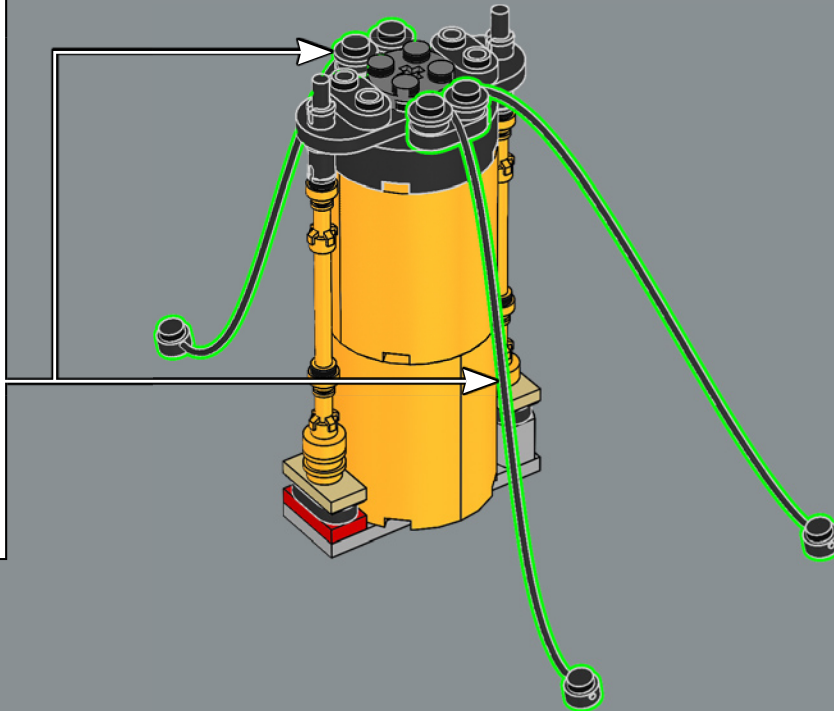
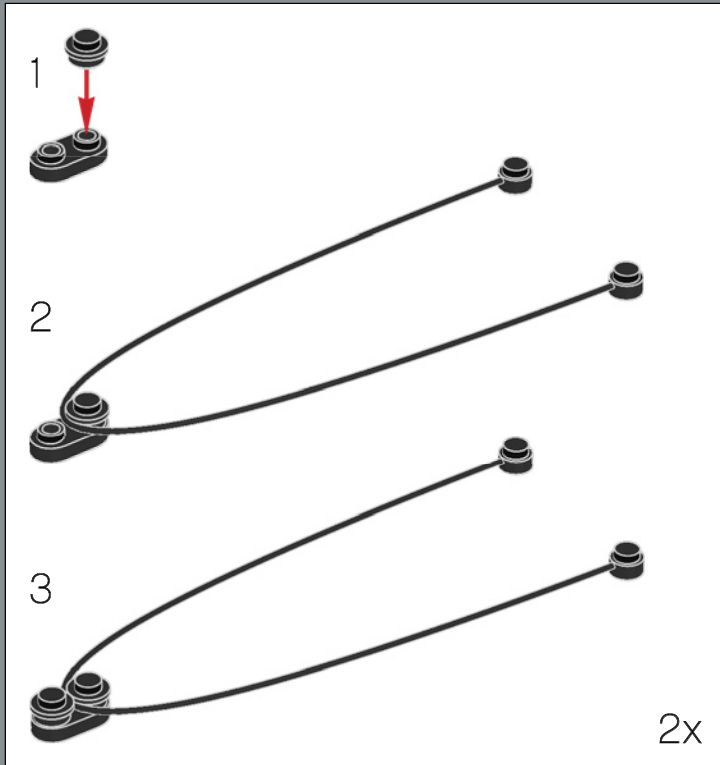

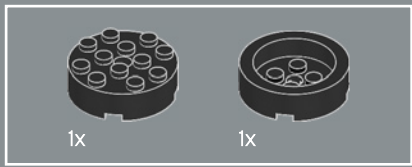

295

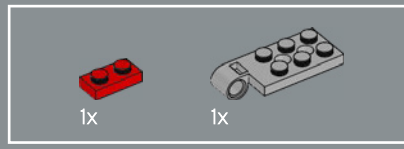
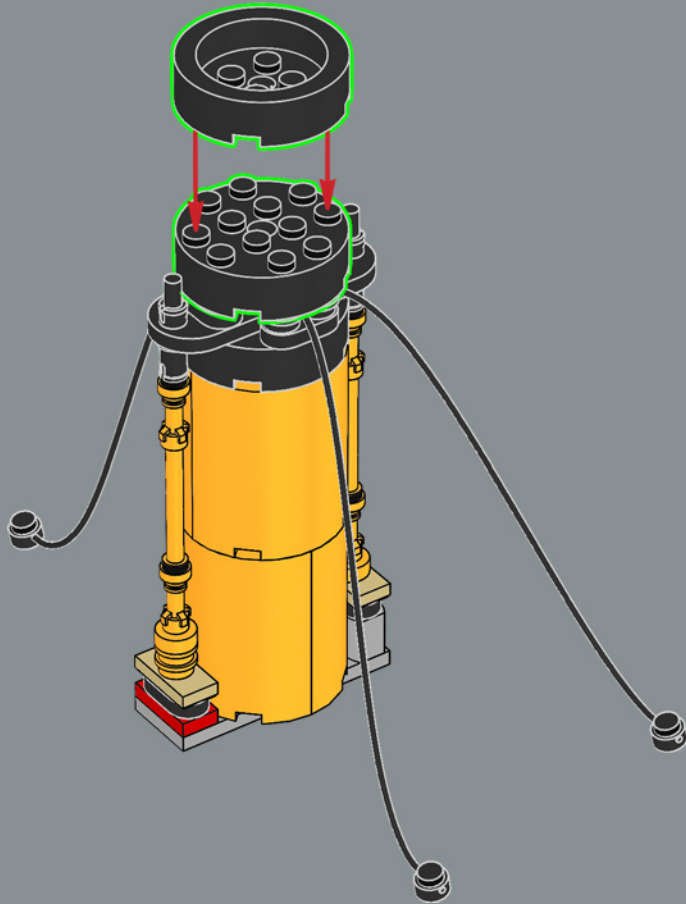

296

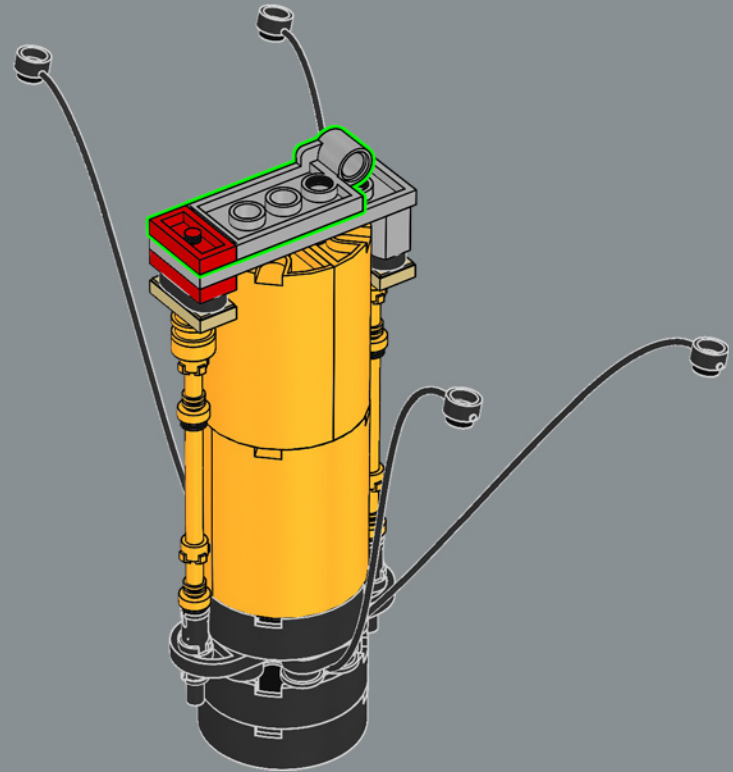

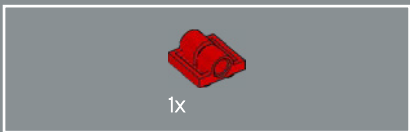

297

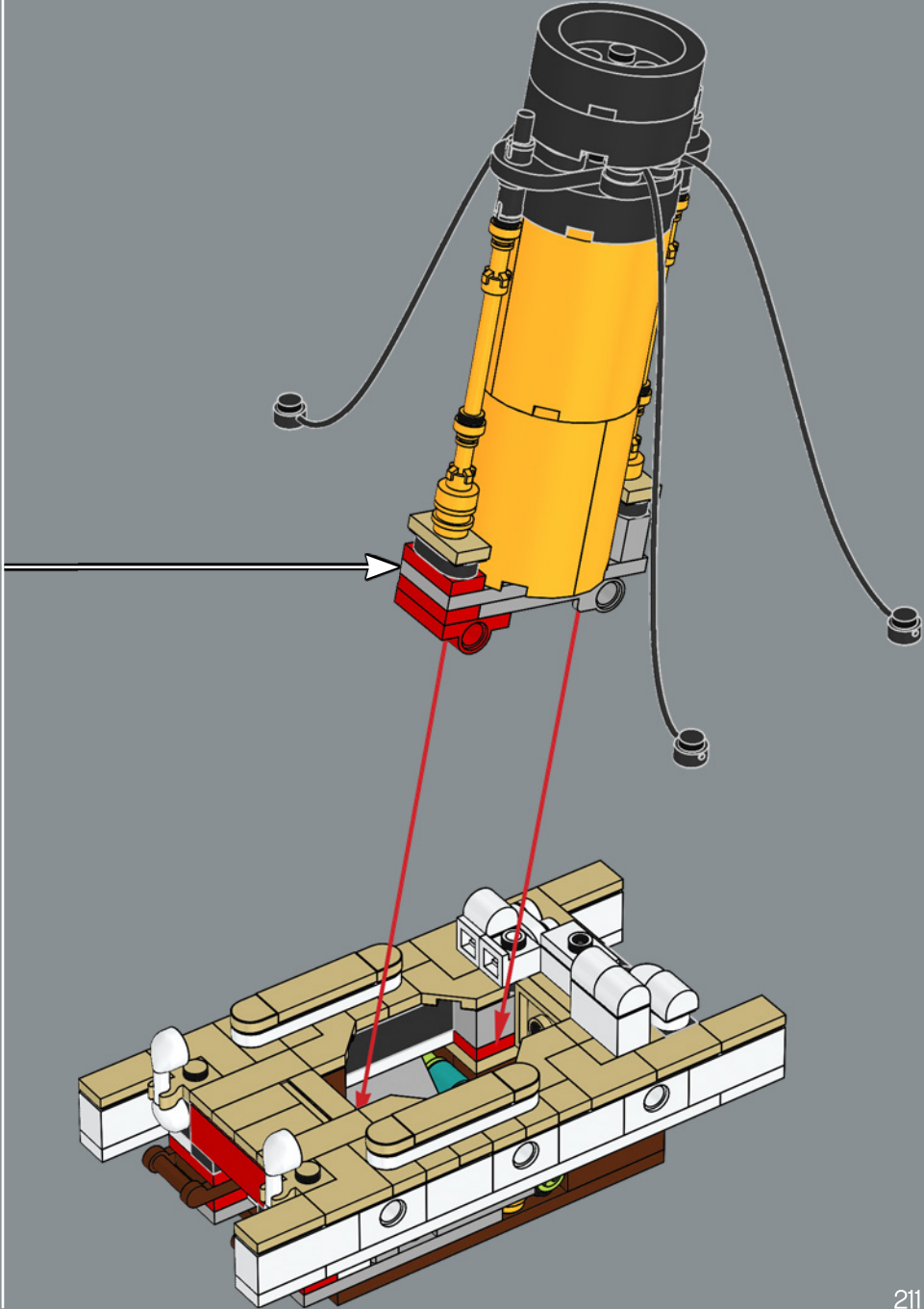
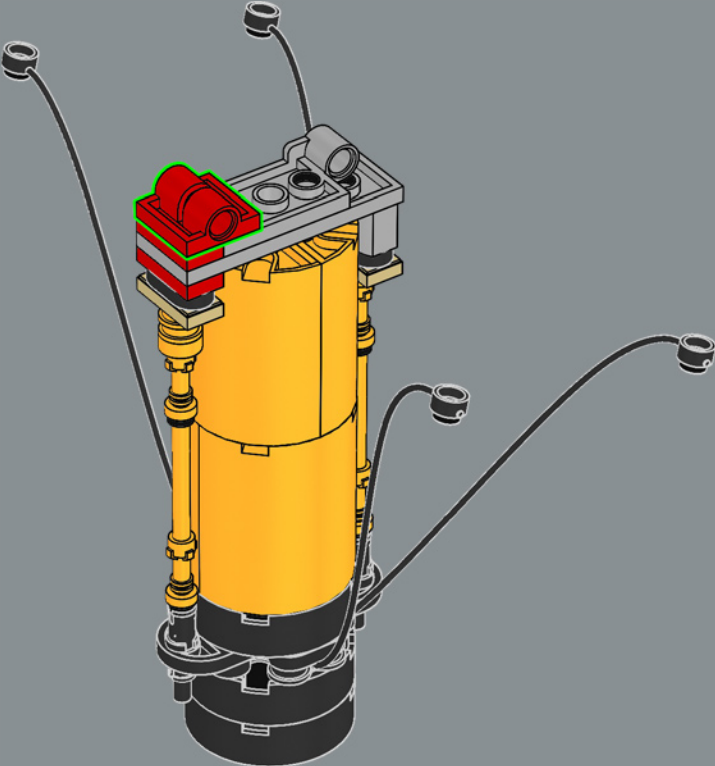

Im Funkraum des Schiffes befanden sich zwei der leistungsstärksten Sender der Welt mit einem garantierten Senderadius von mehr als 563 km.

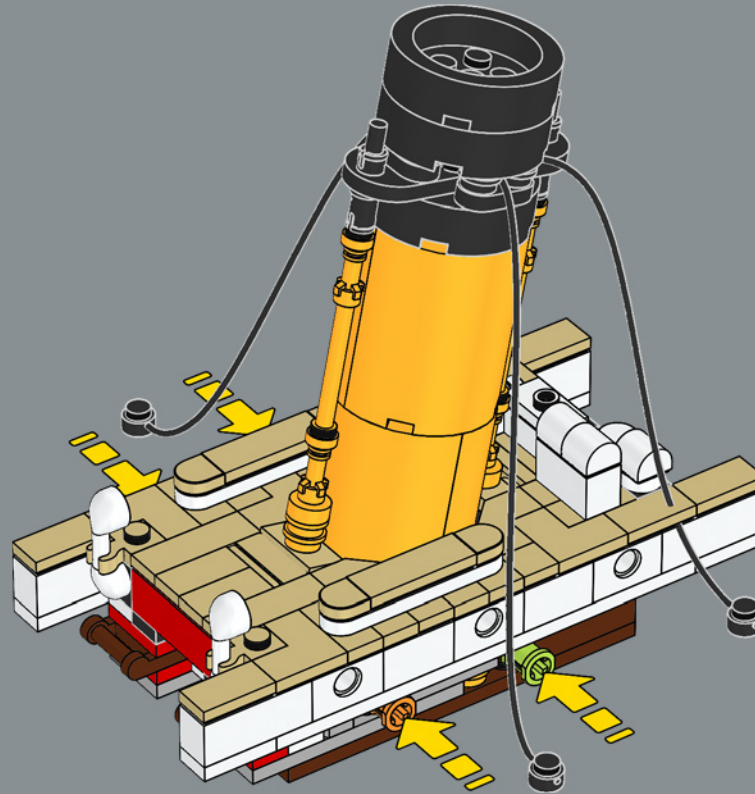

299

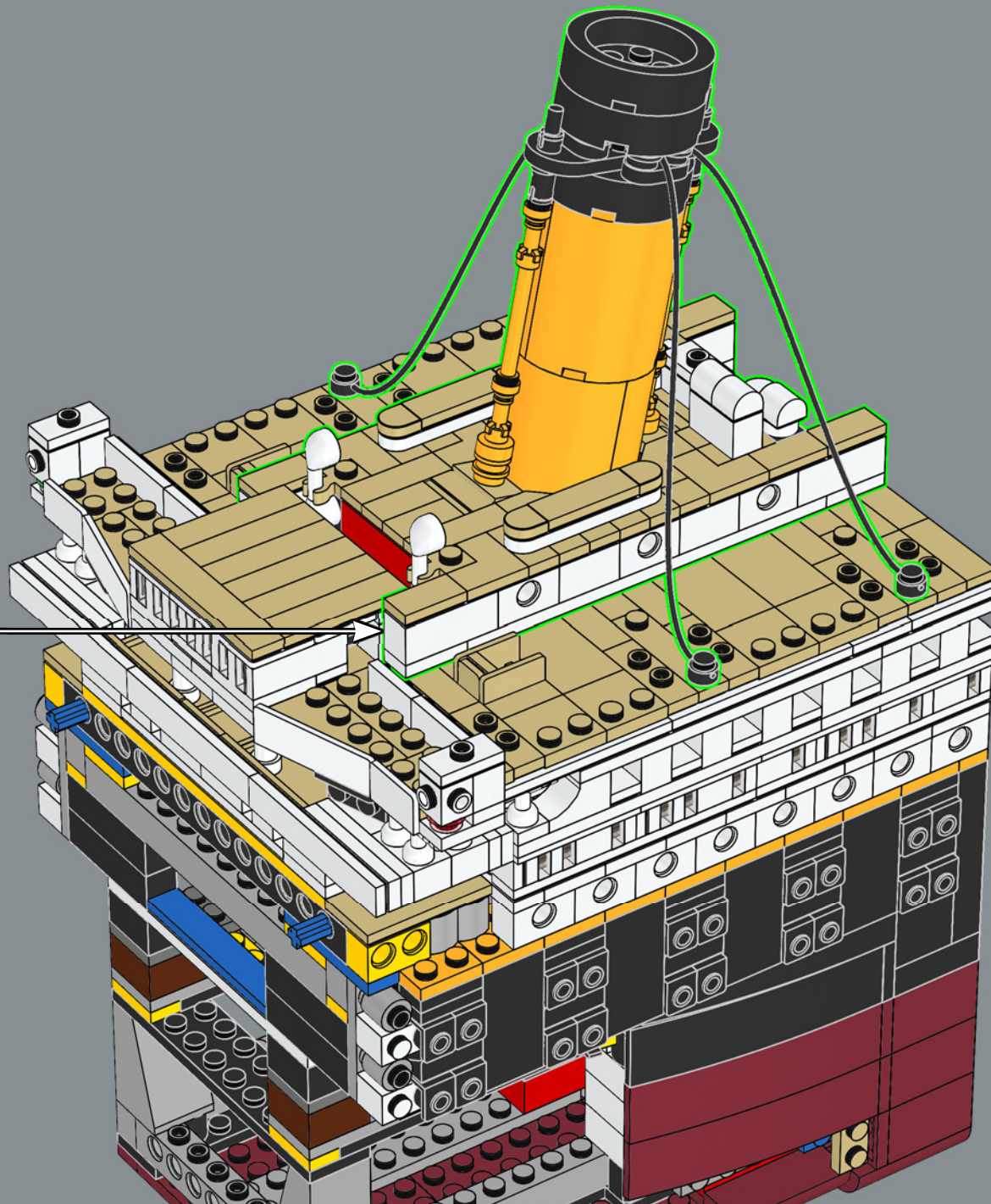

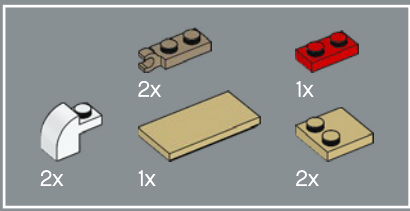

300

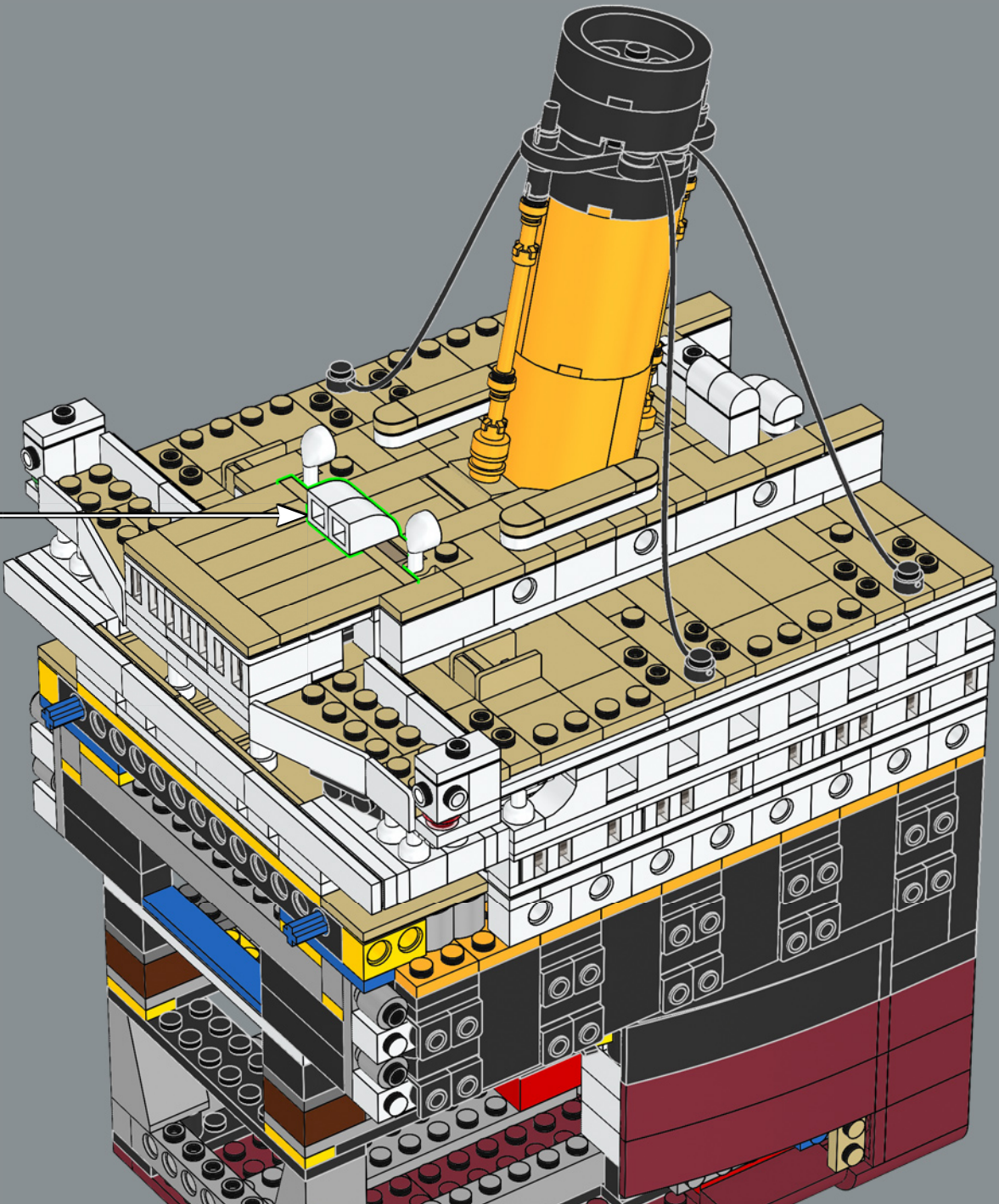
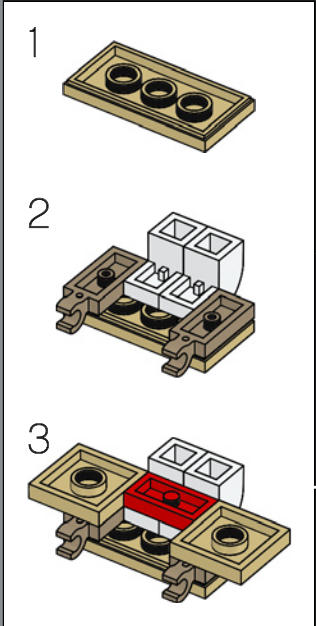

301

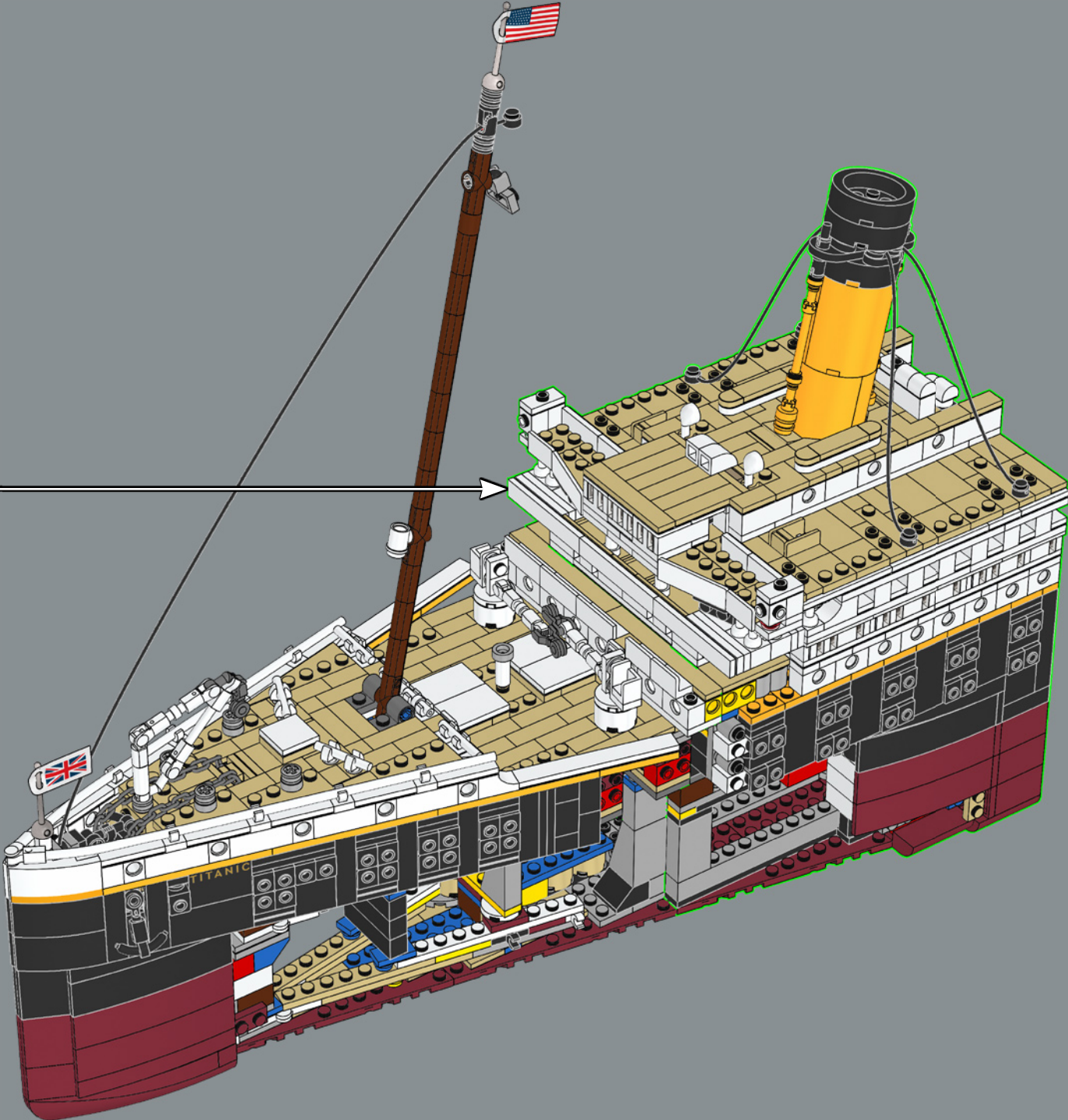

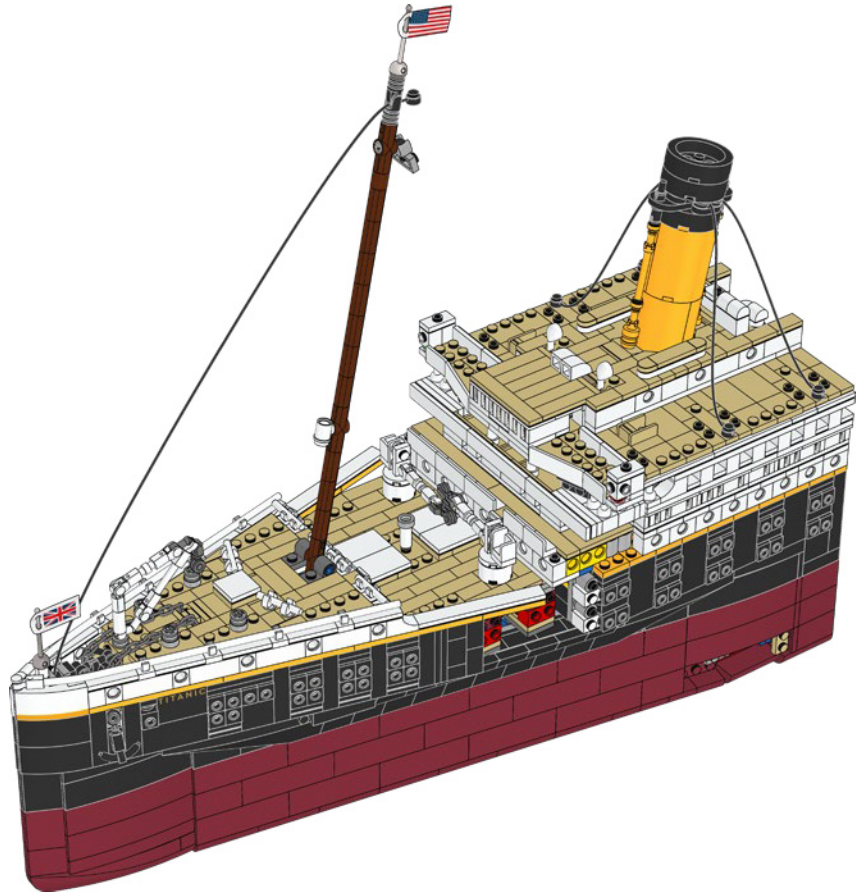
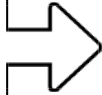



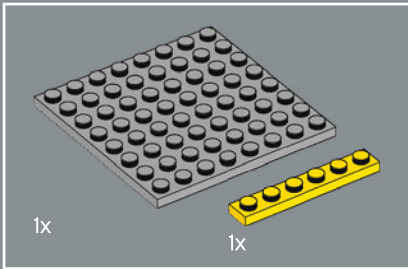
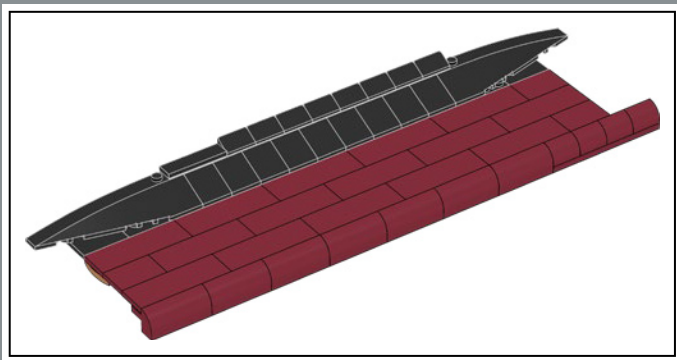

302

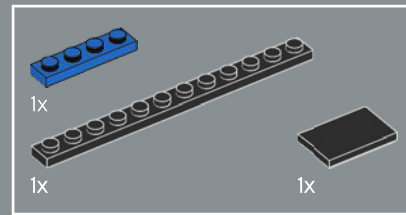
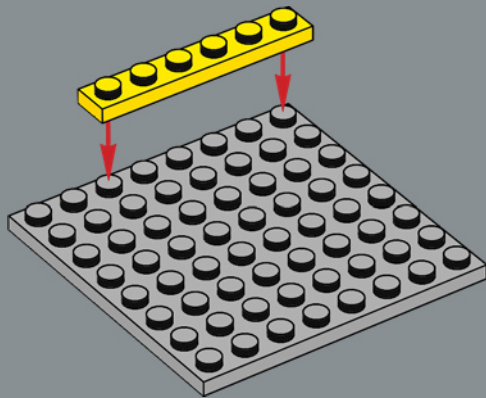

303

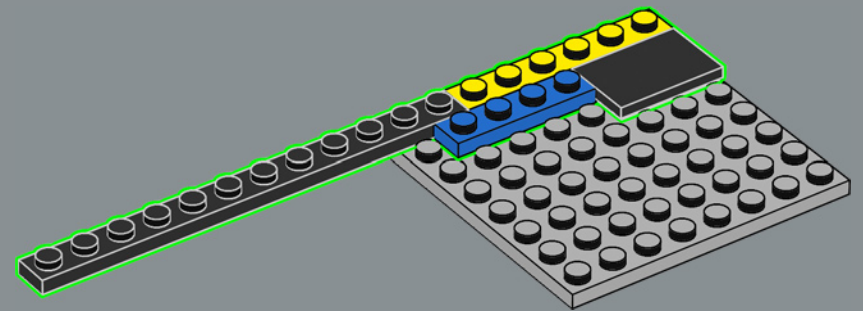

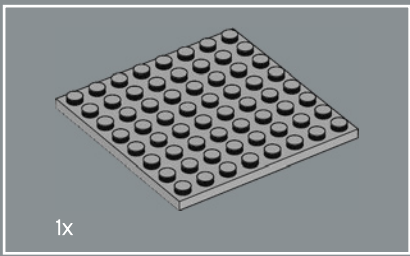

304

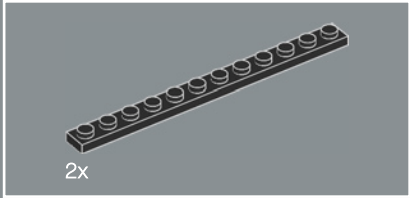
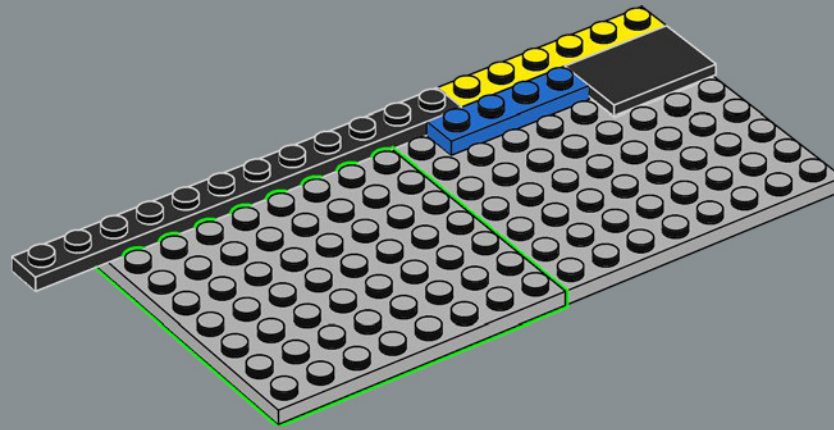

305

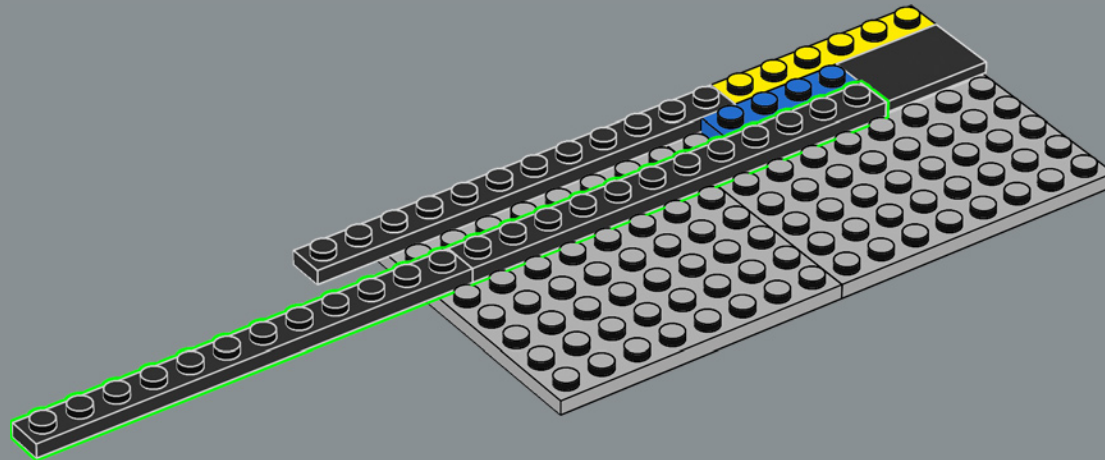

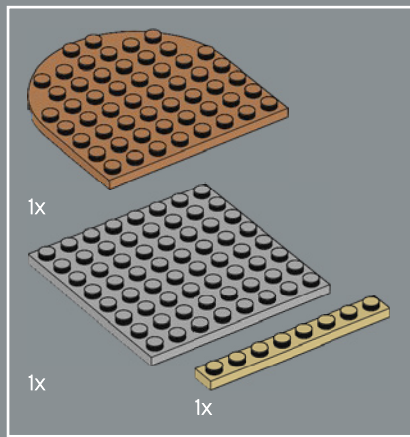

306

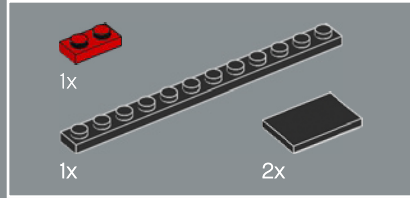
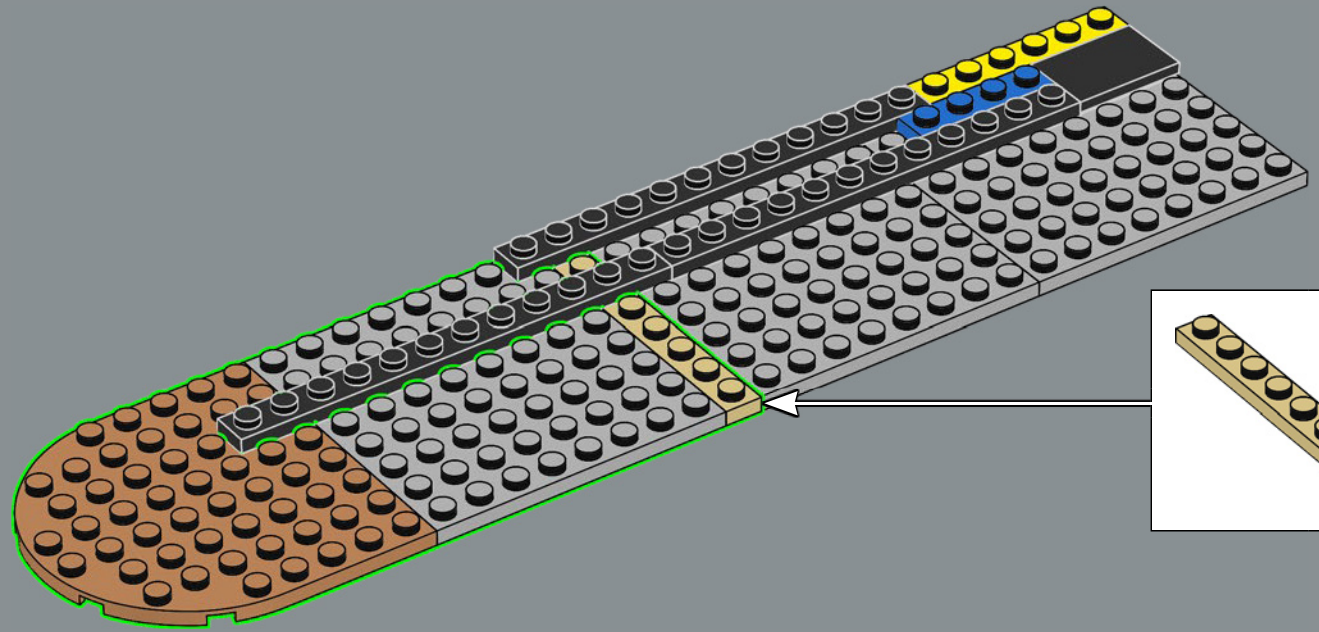

307

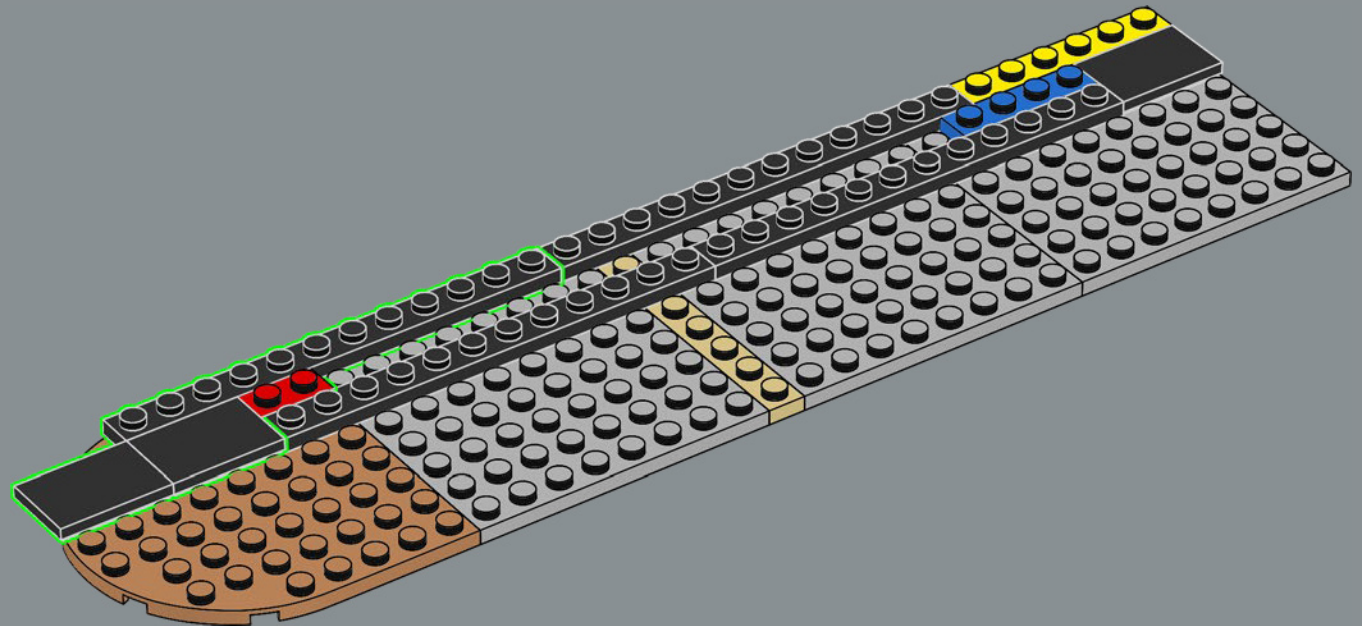

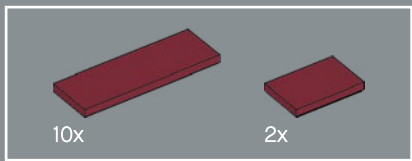

308

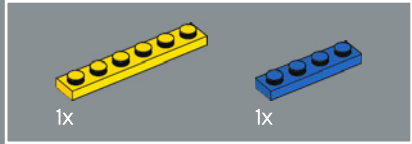
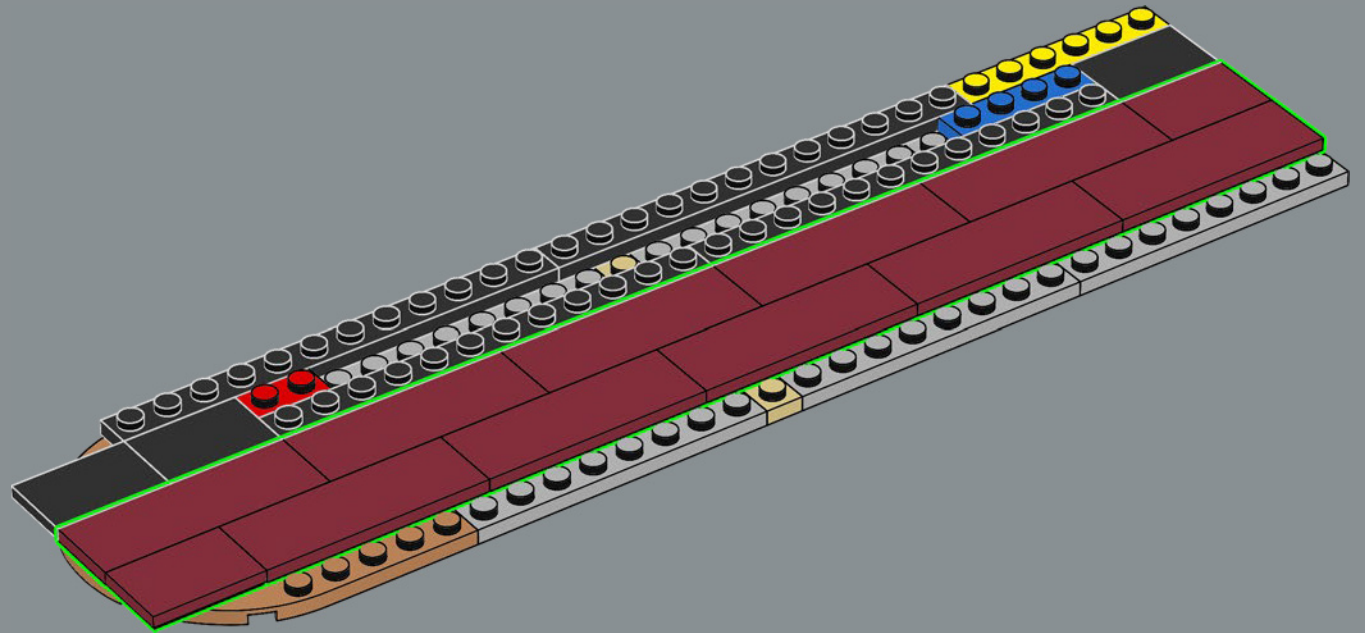

309

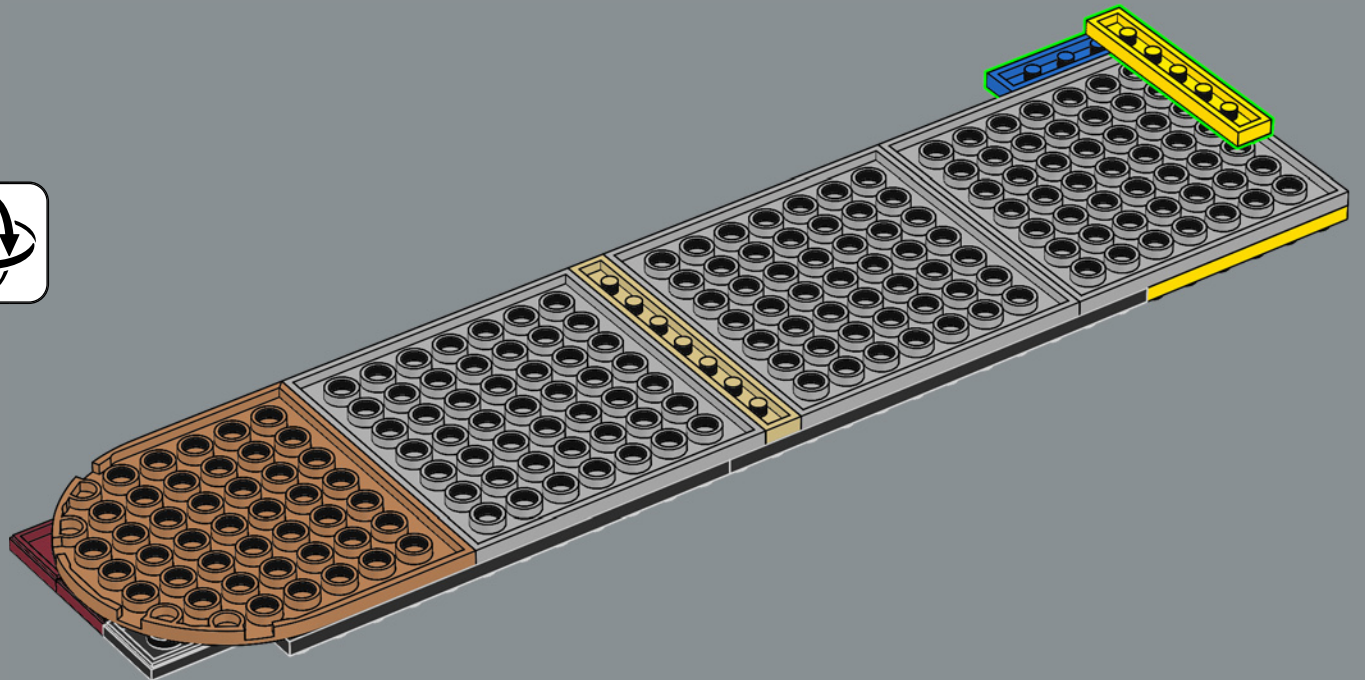

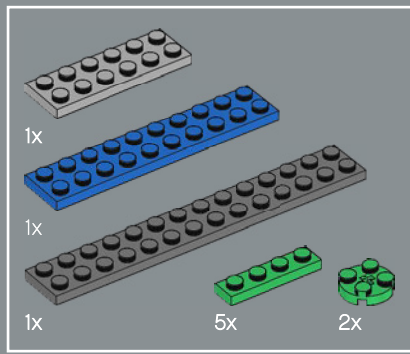

310

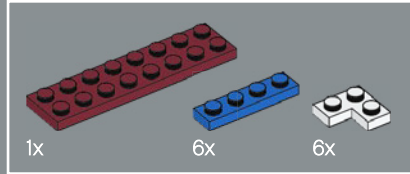
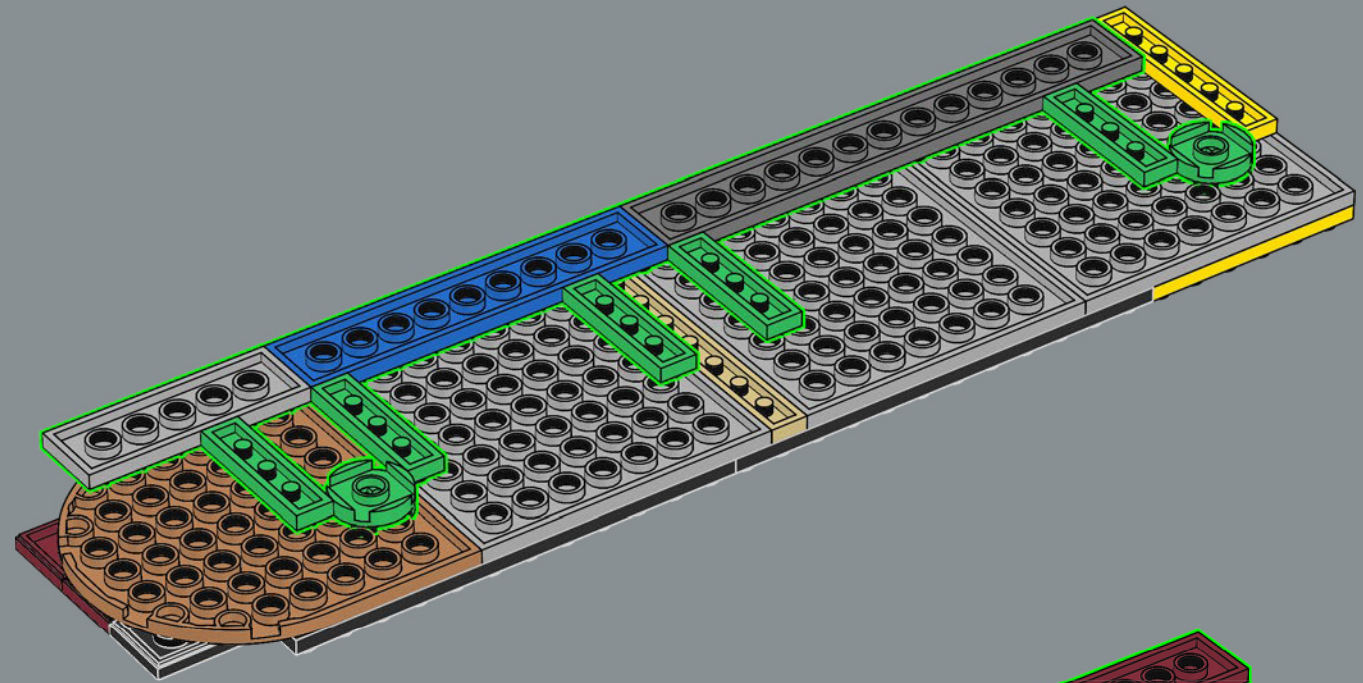

311

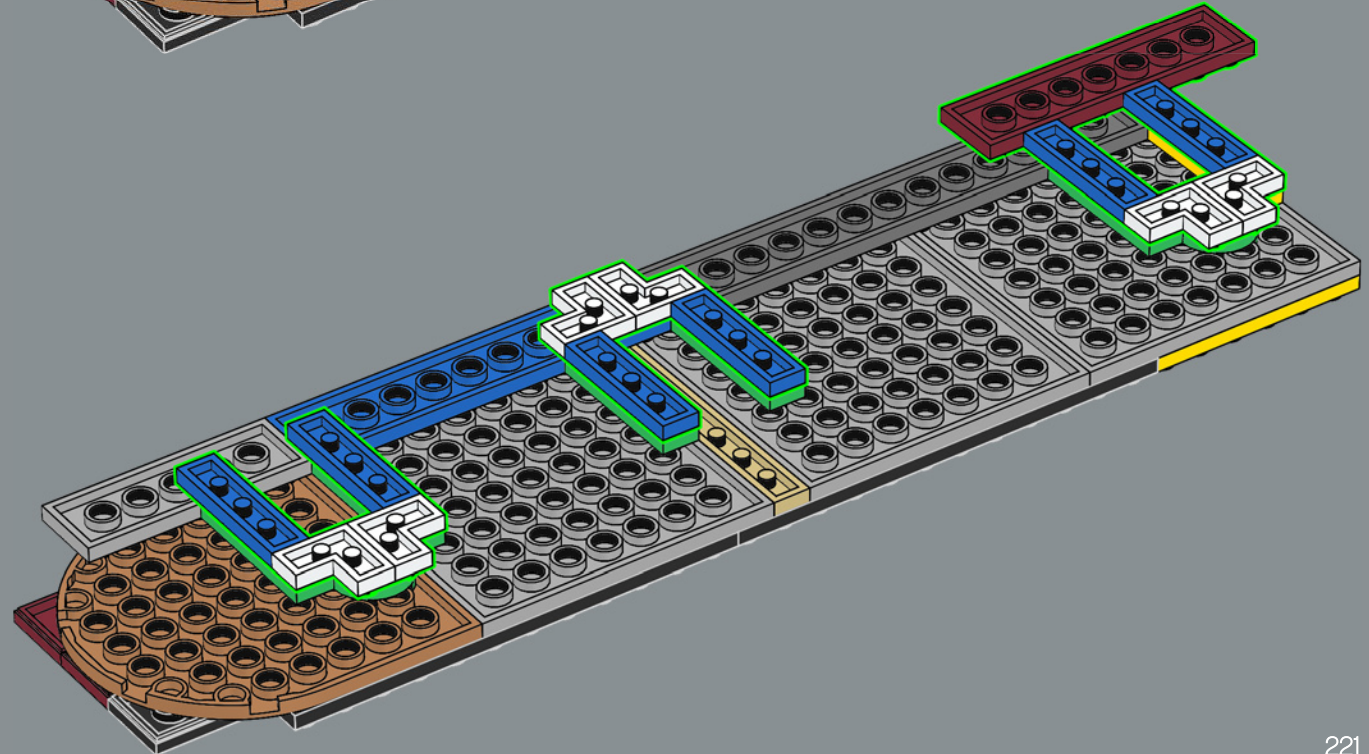

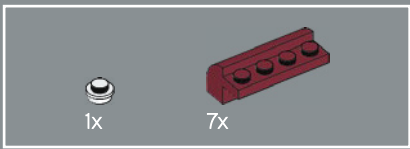

312

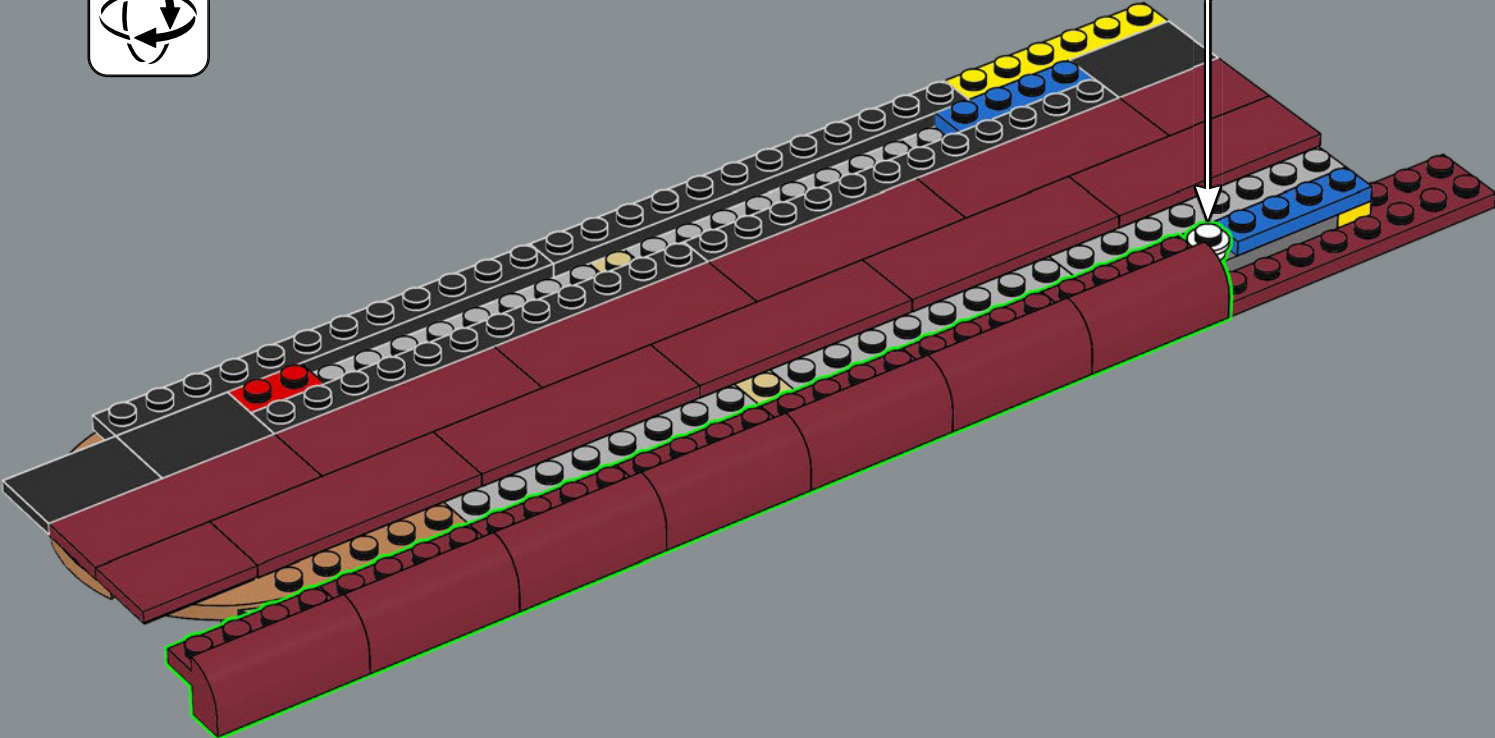

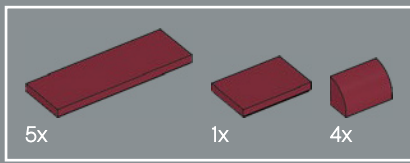

313

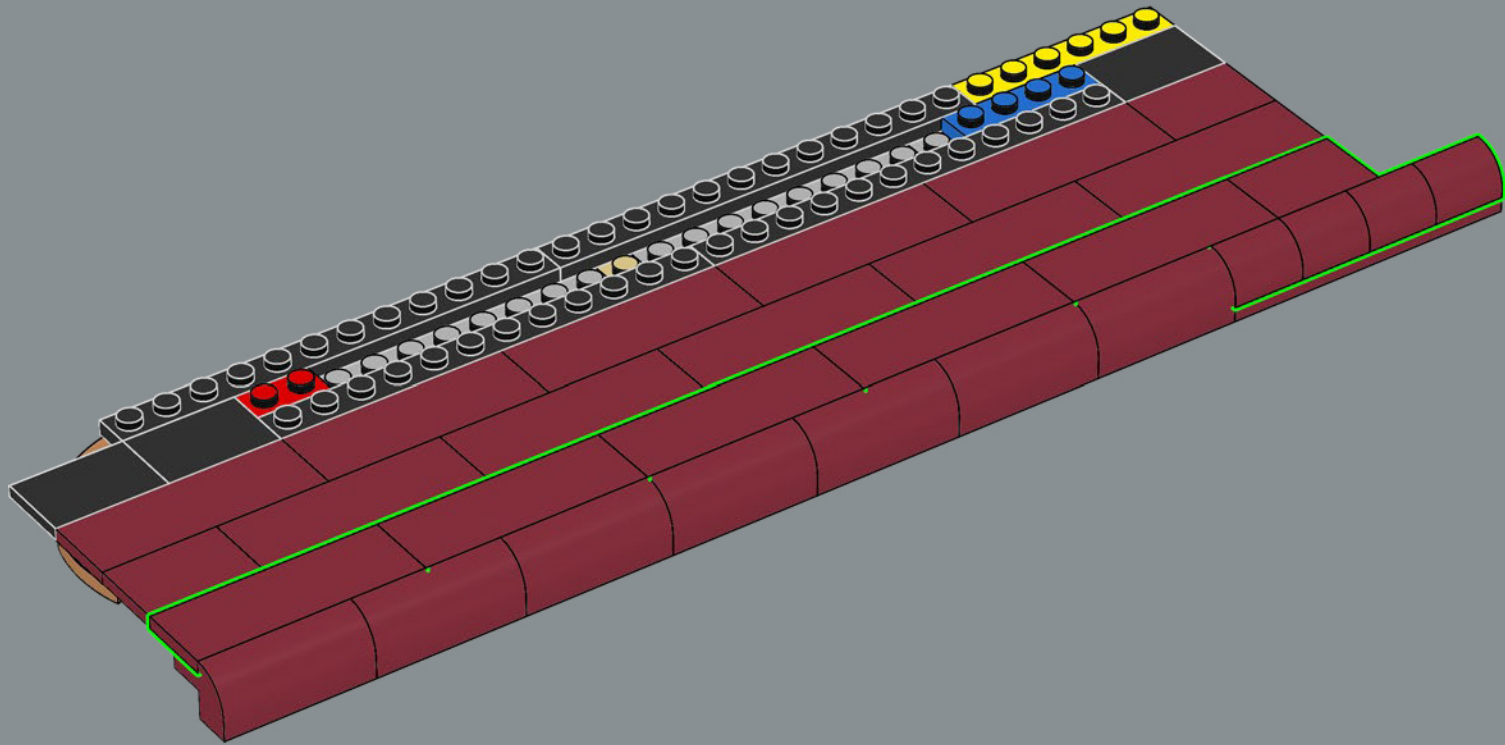

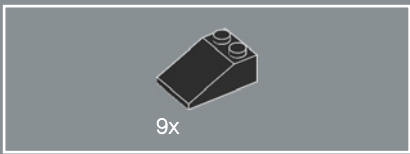

314

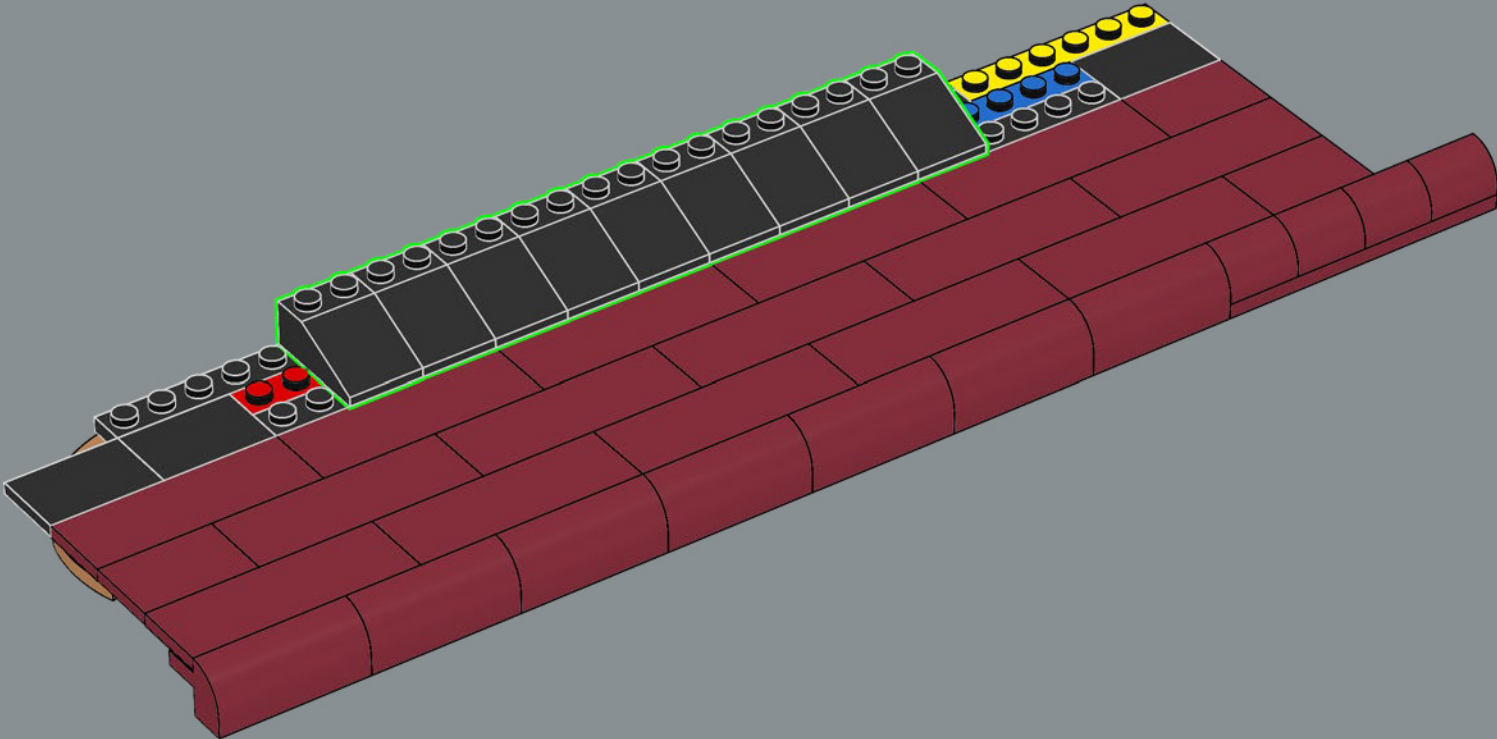



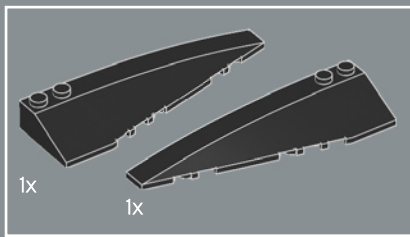

315

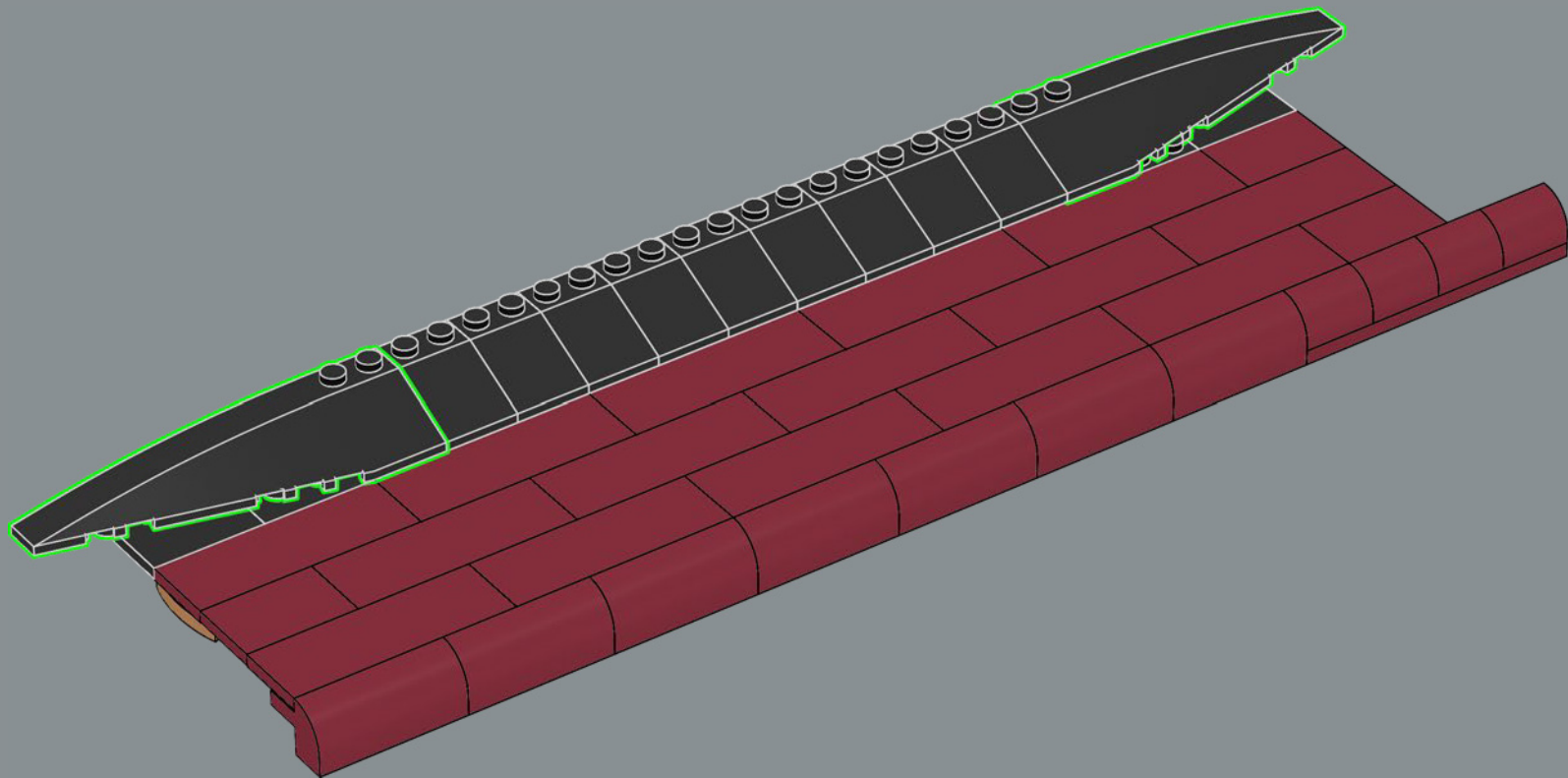

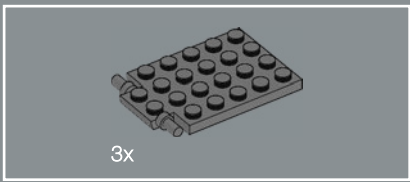

316

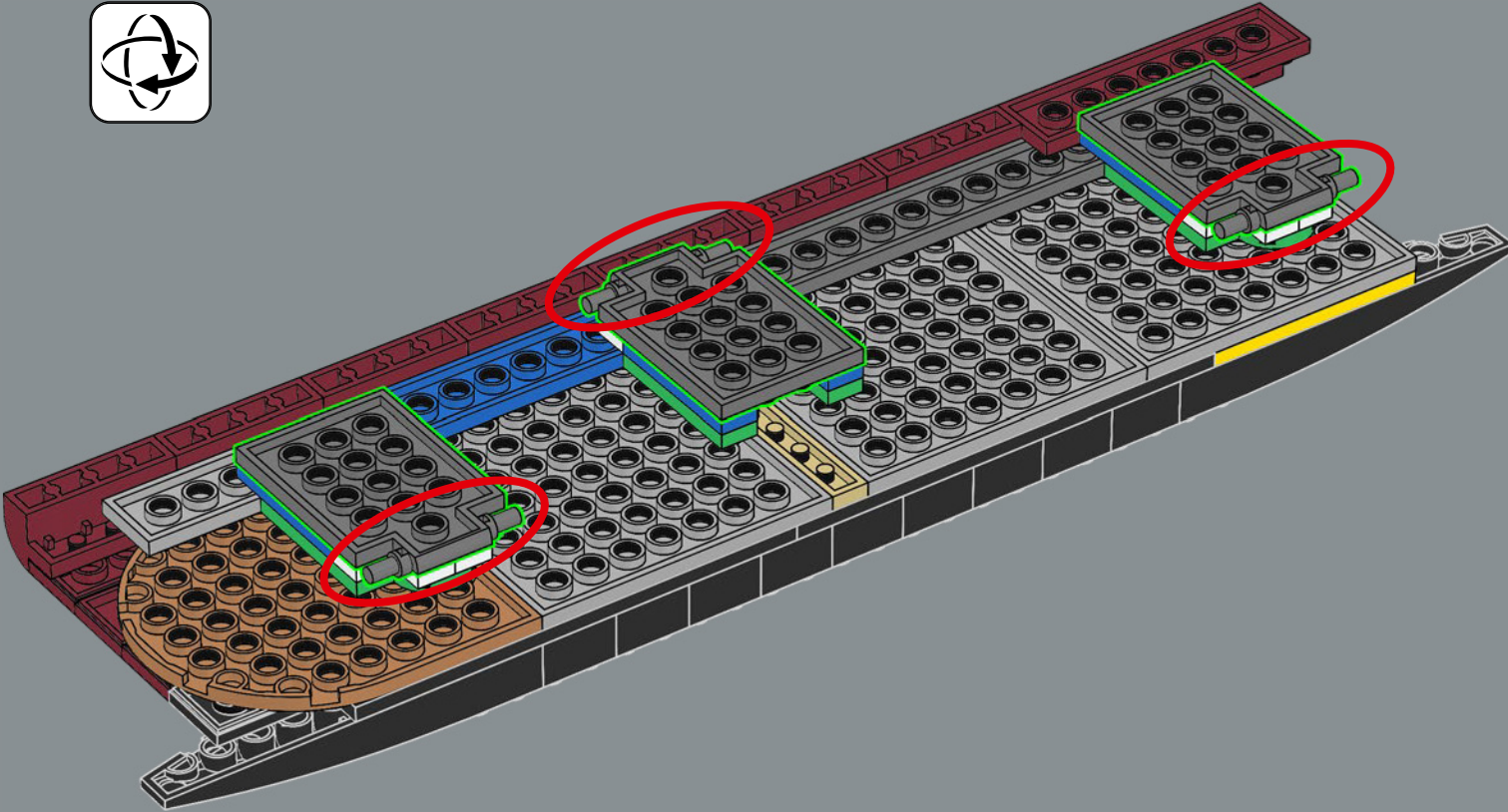



317

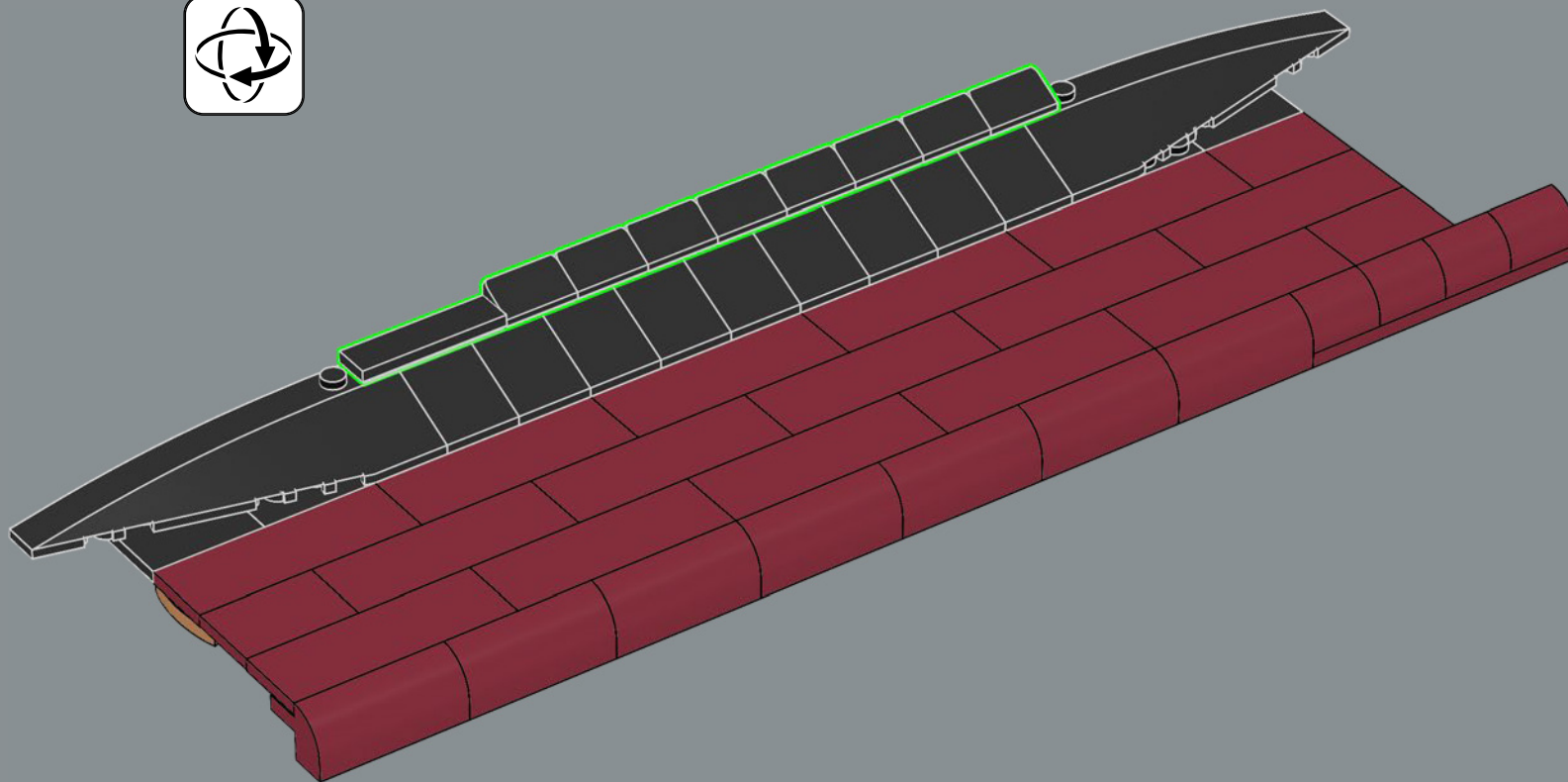

318

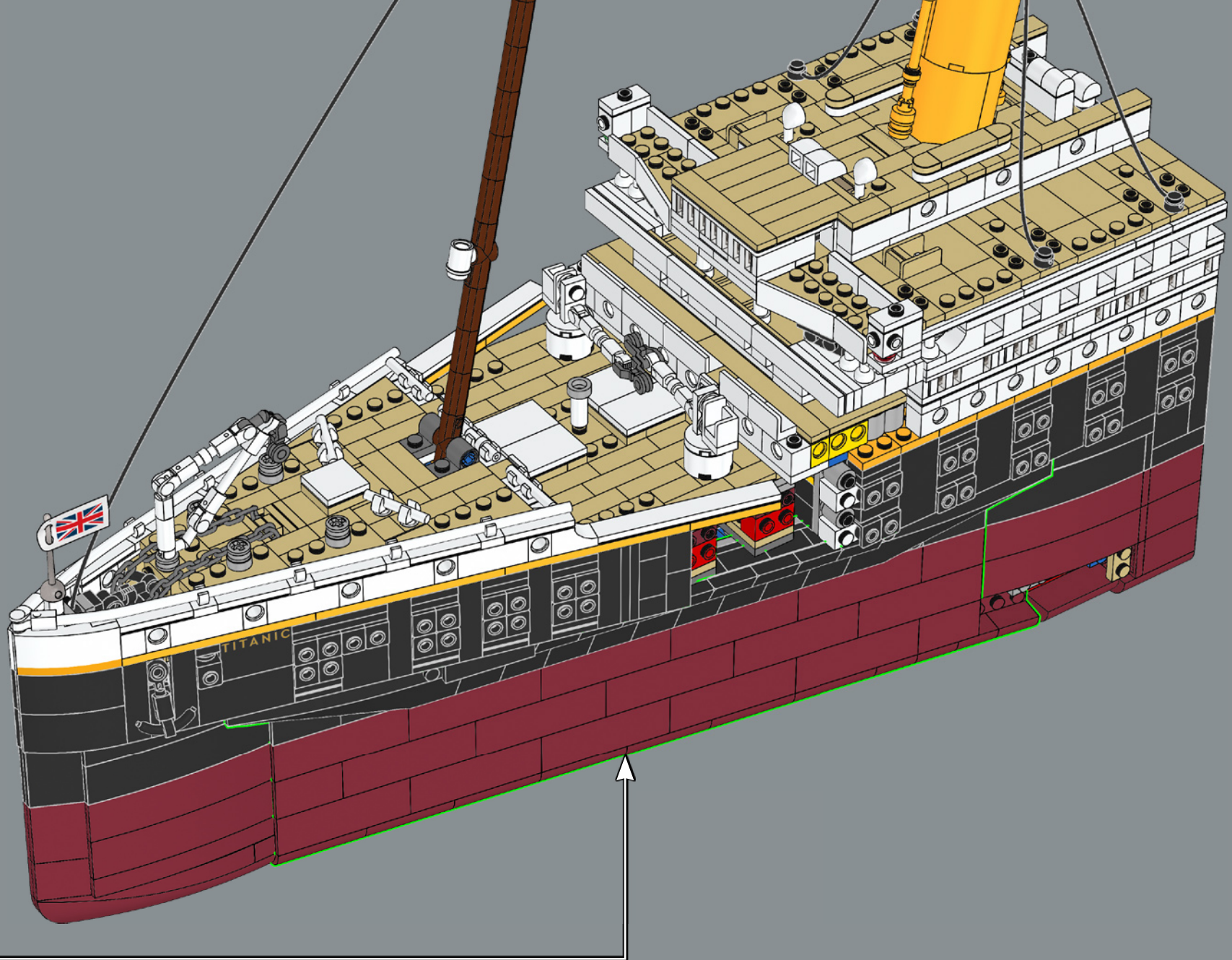

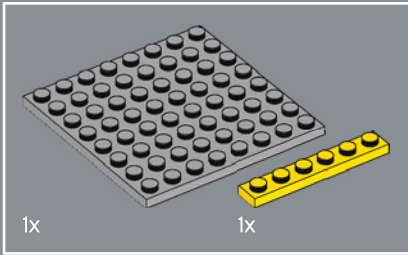
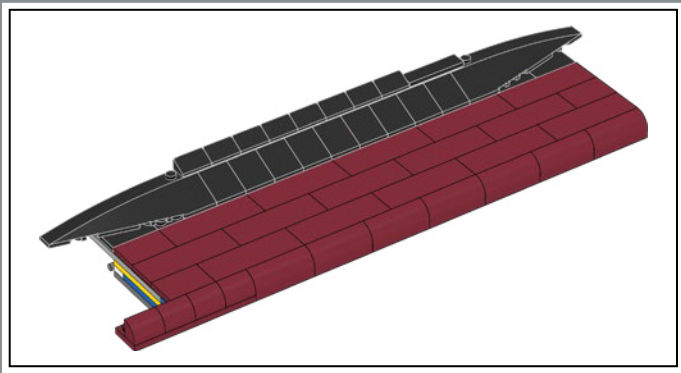

319

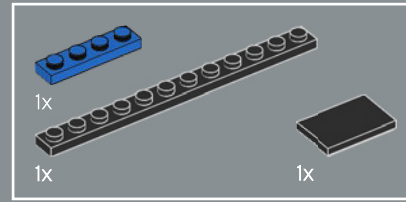
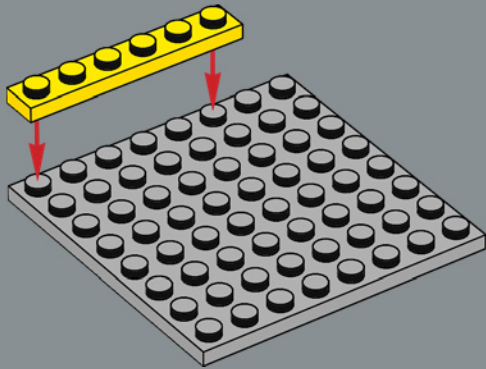

320

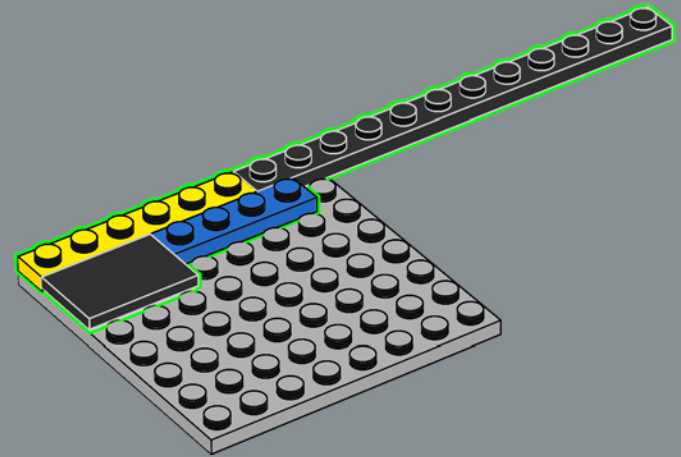

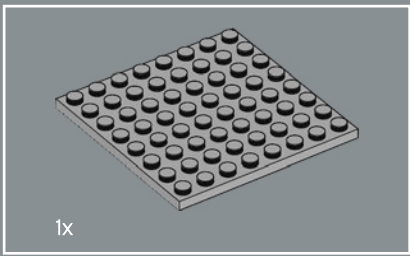

321

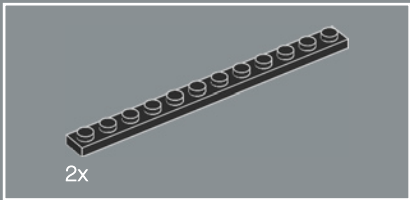
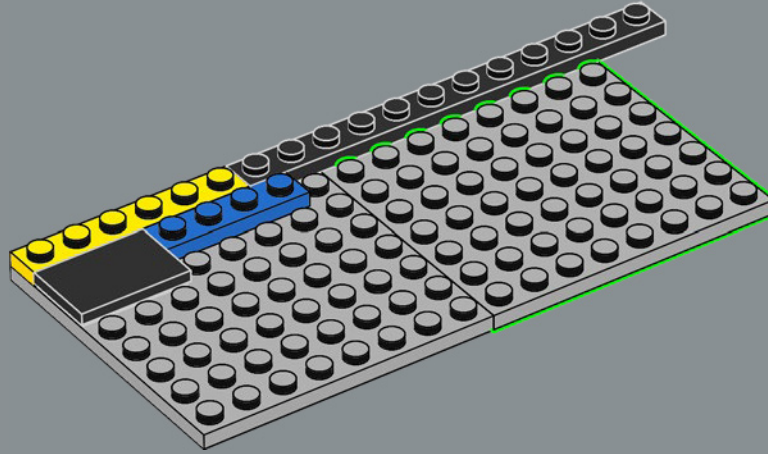

322

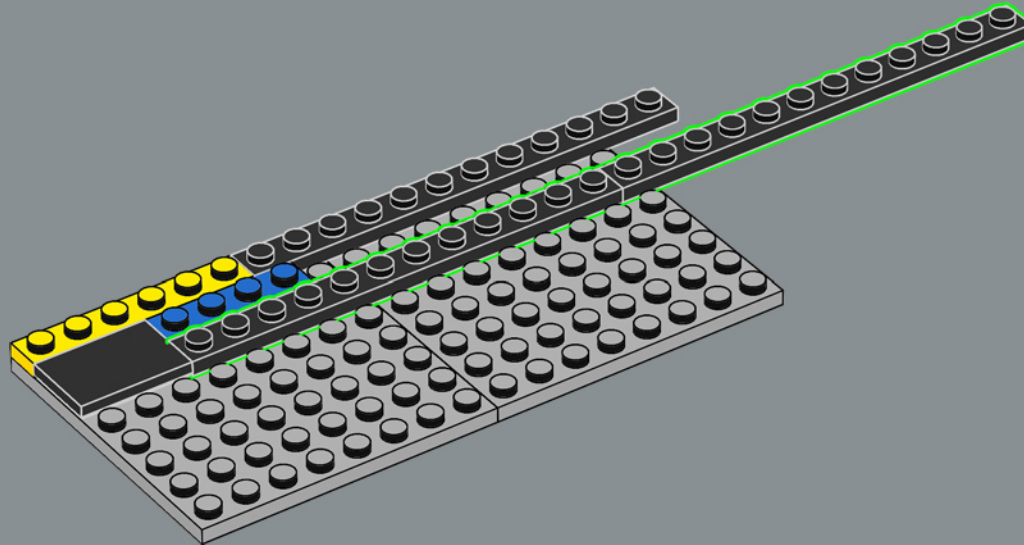

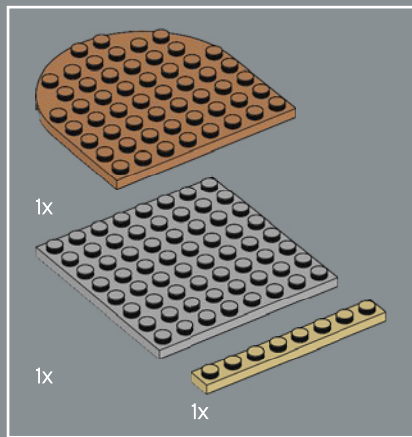

323

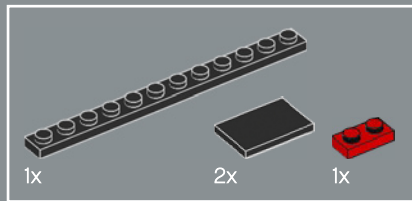
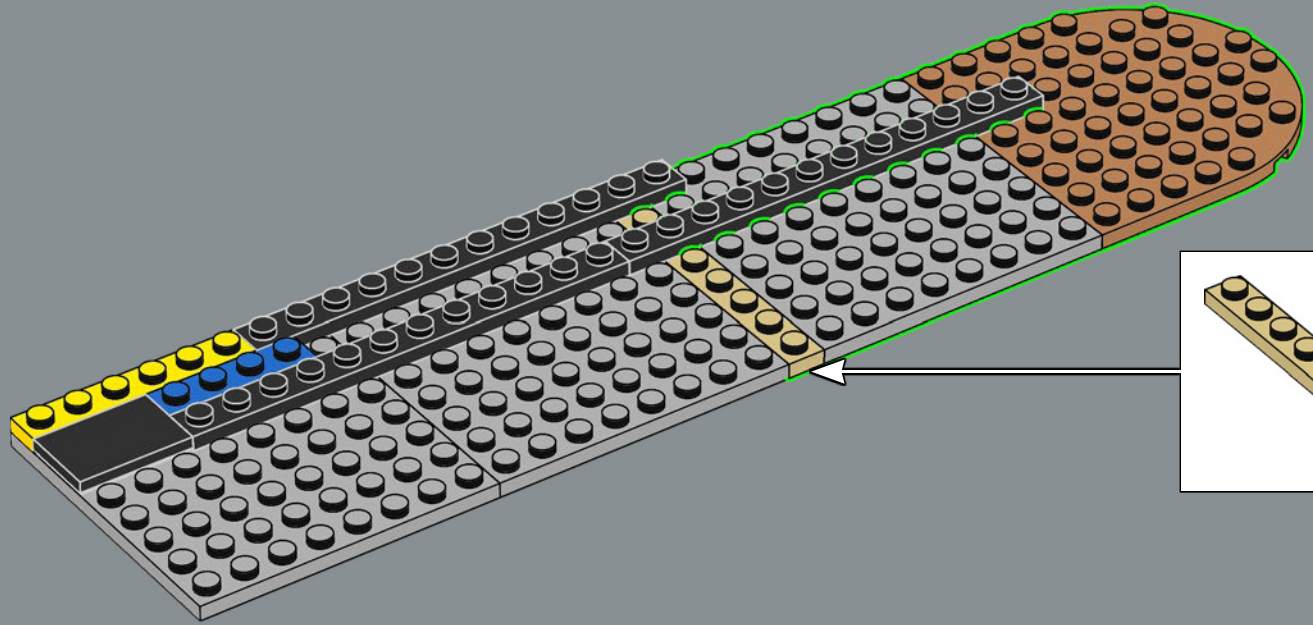

324

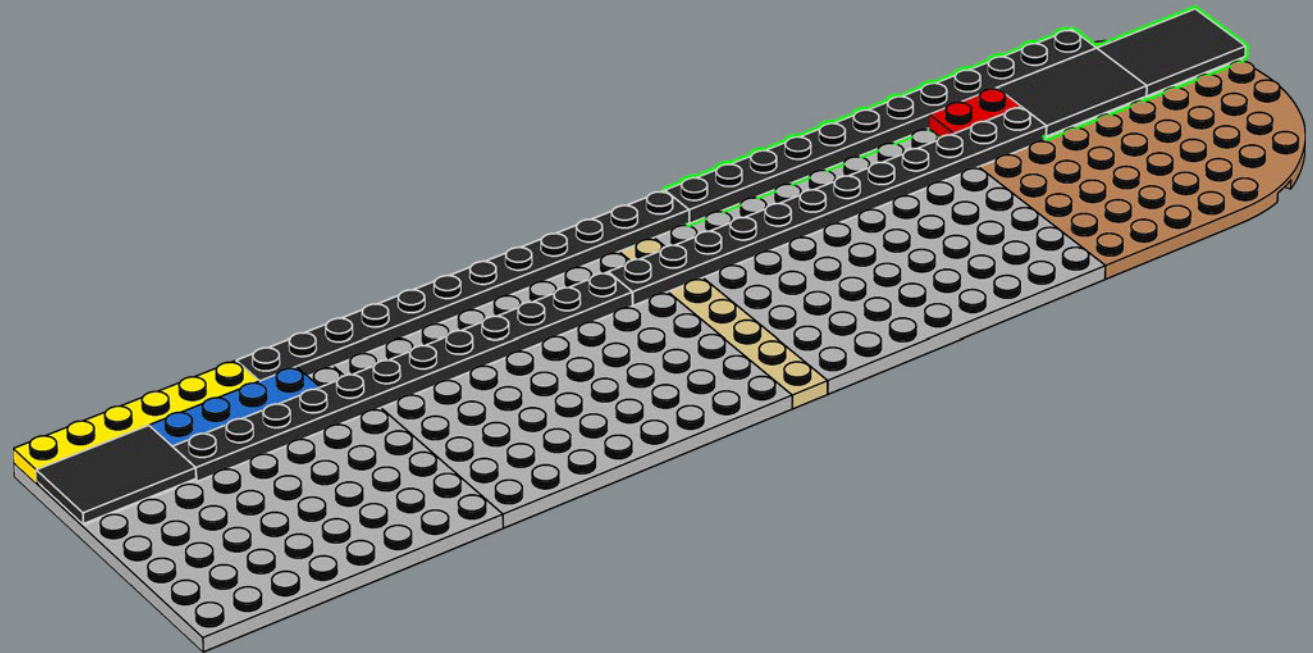

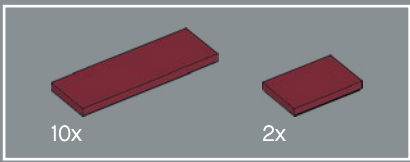

325

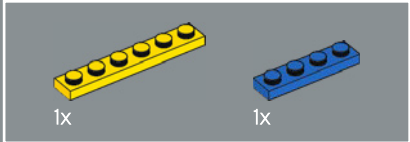
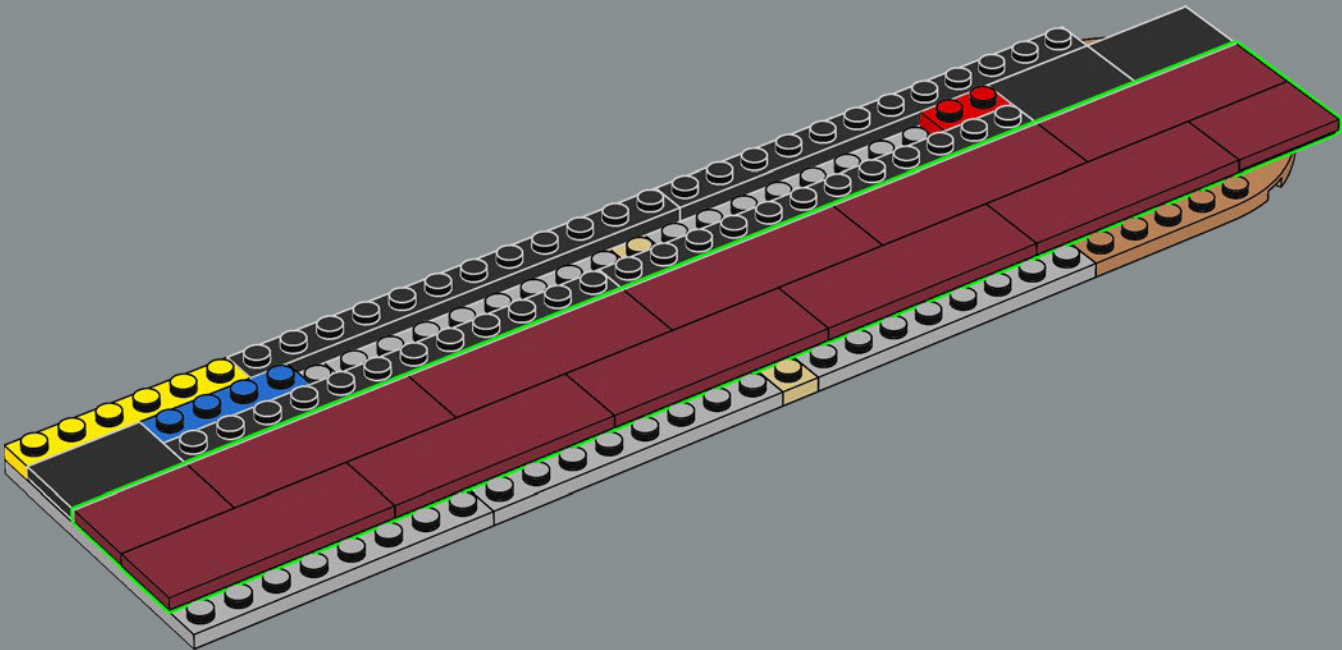

326

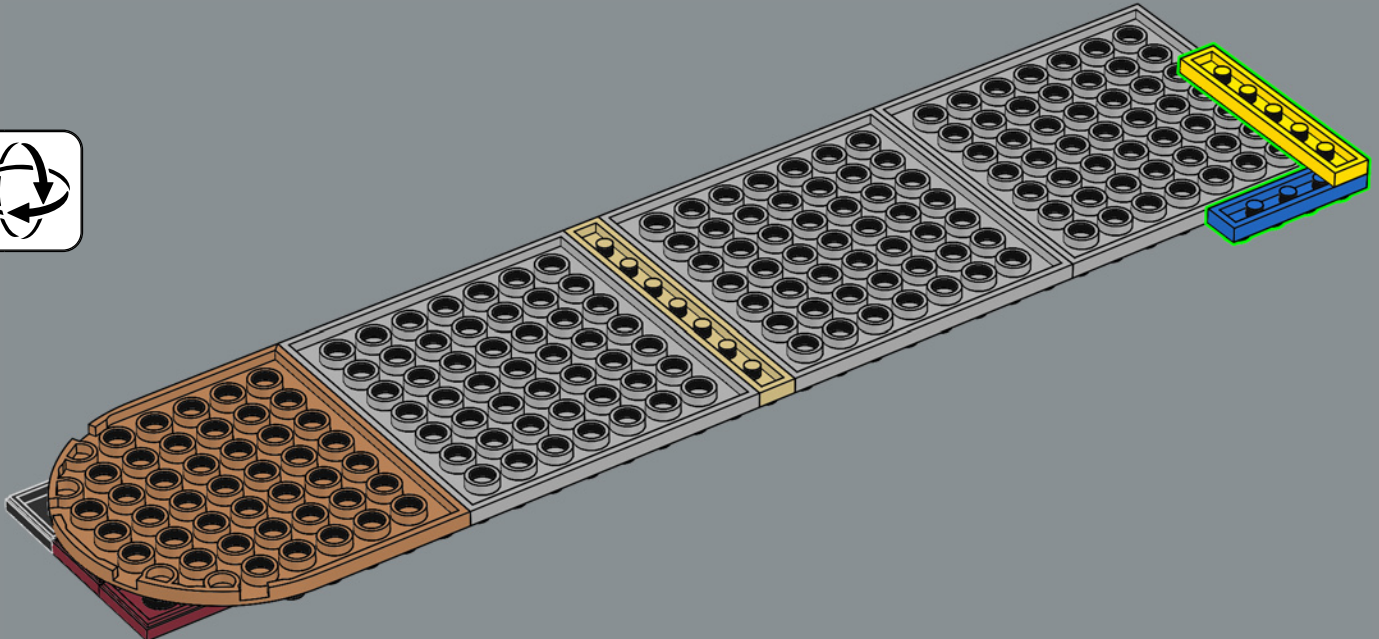



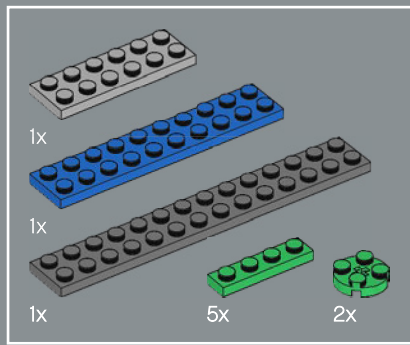

327

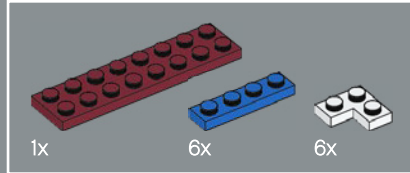
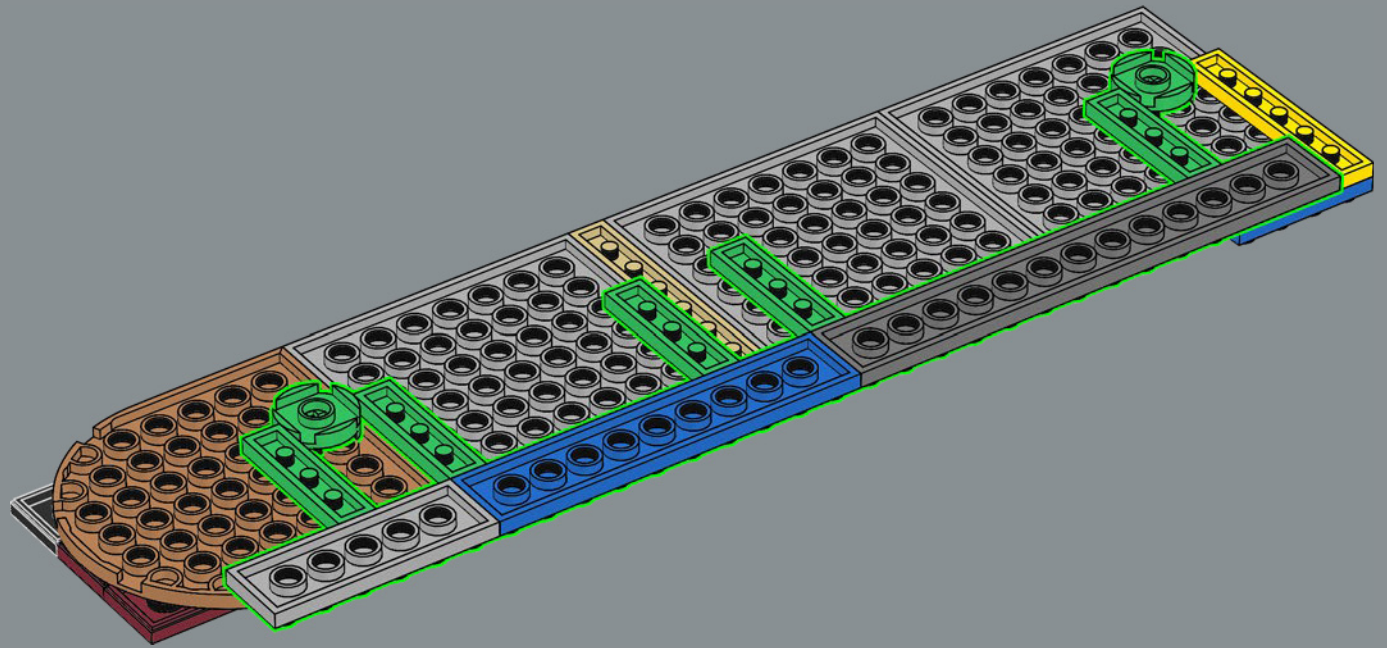

328

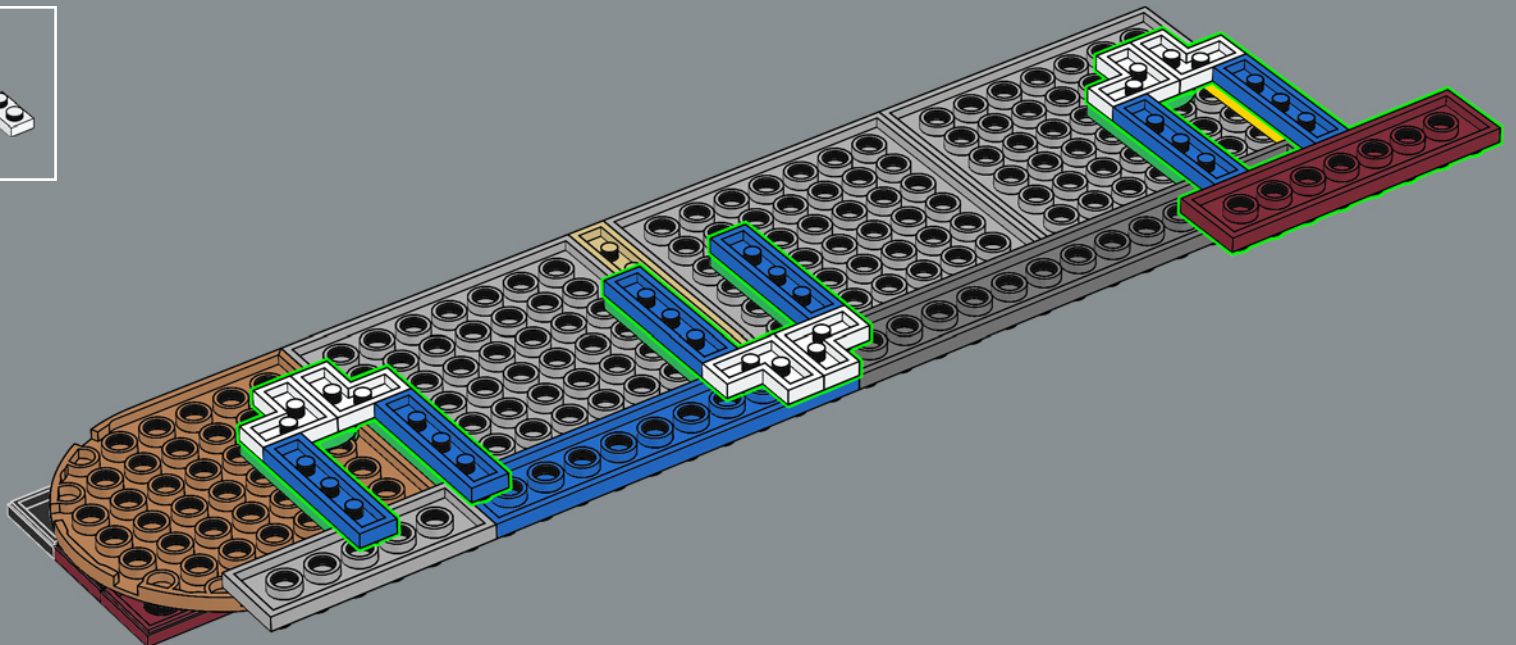

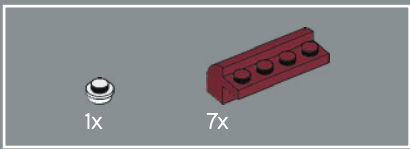

329

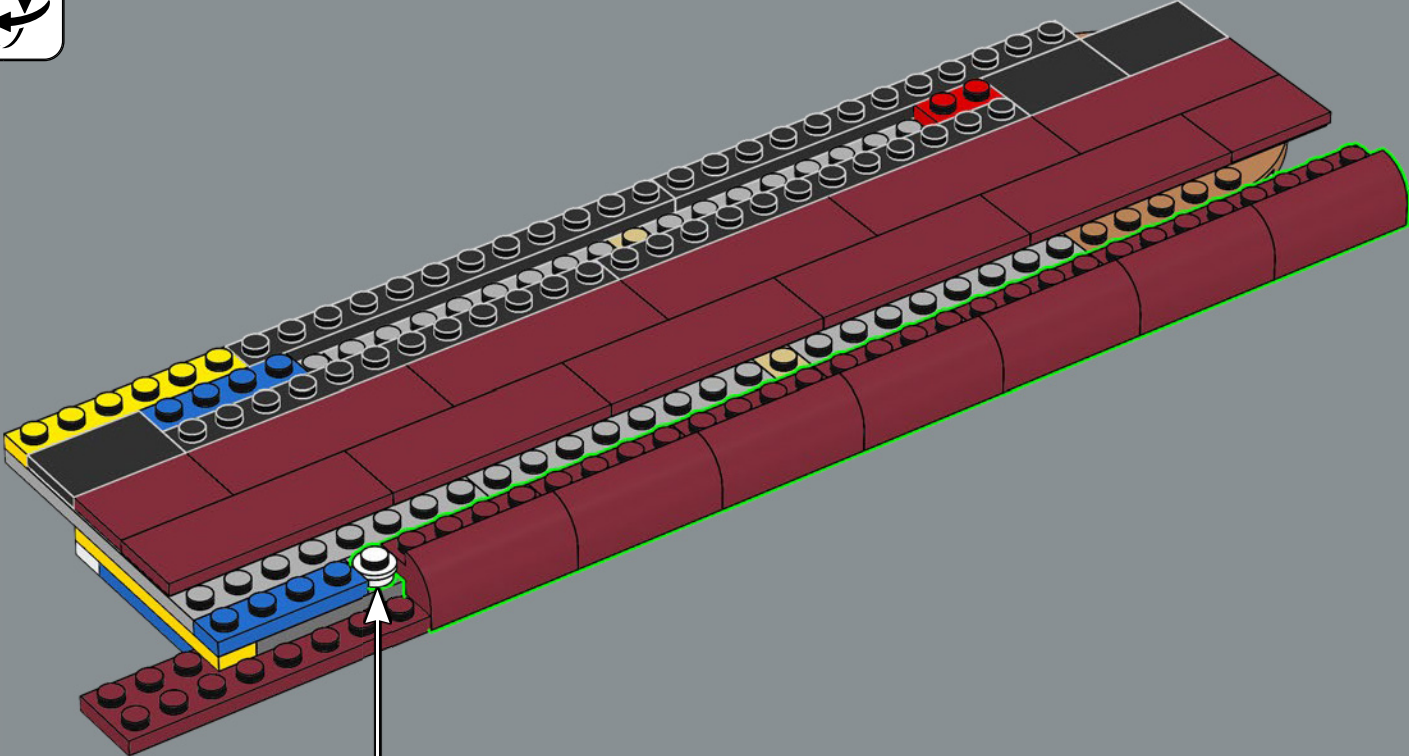

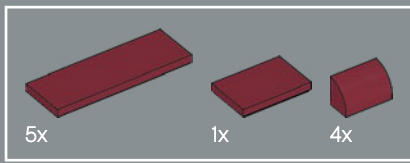

330

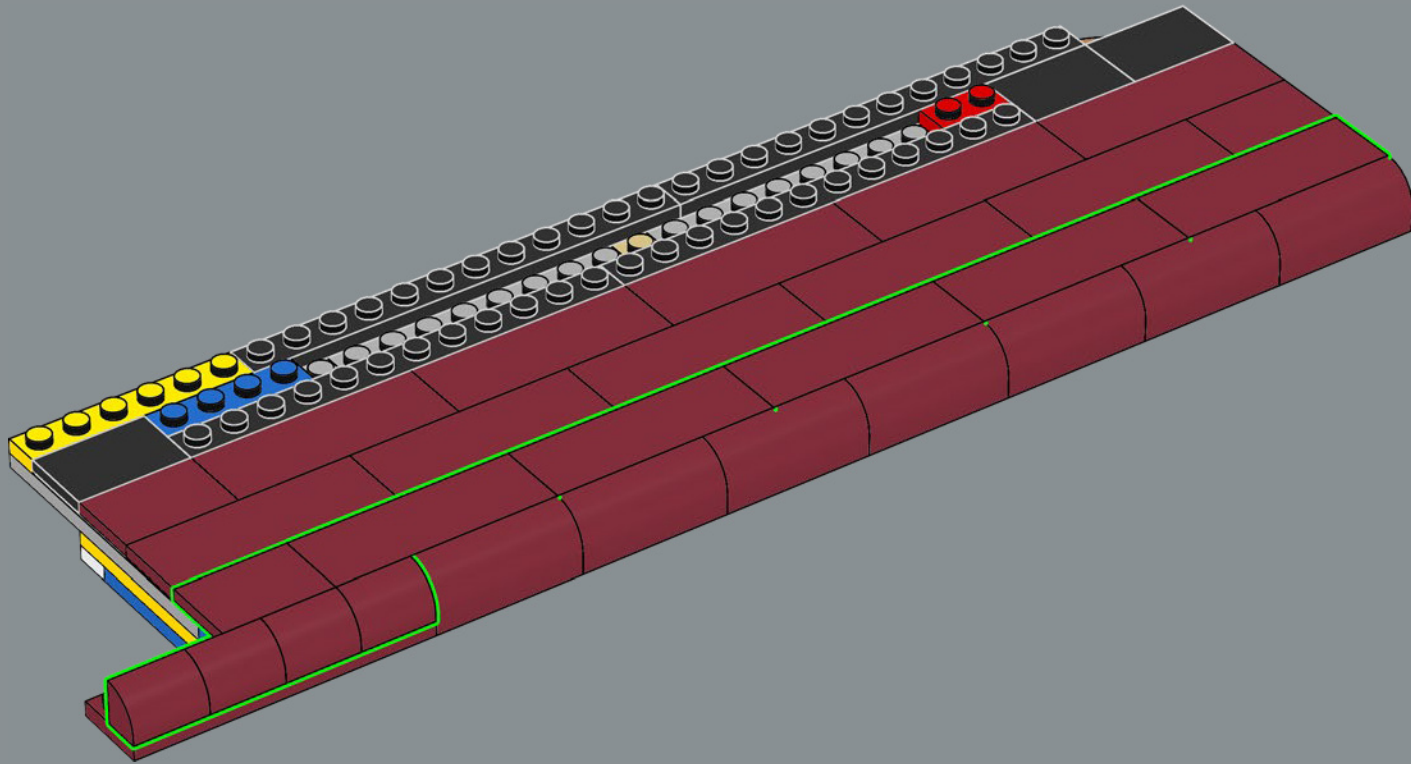

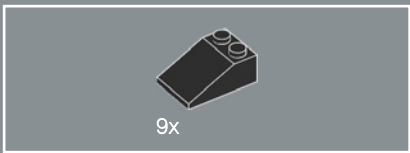

331

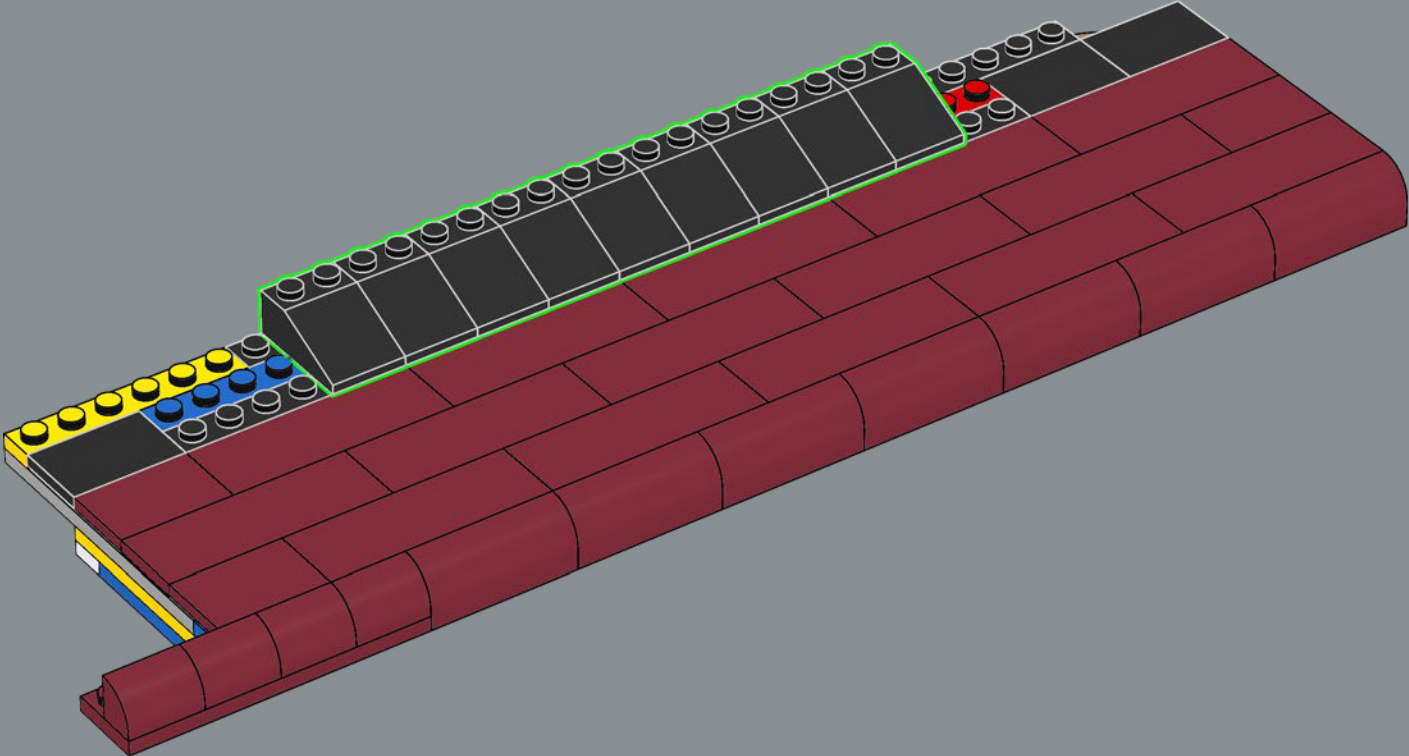

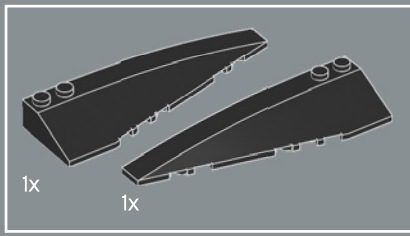

332

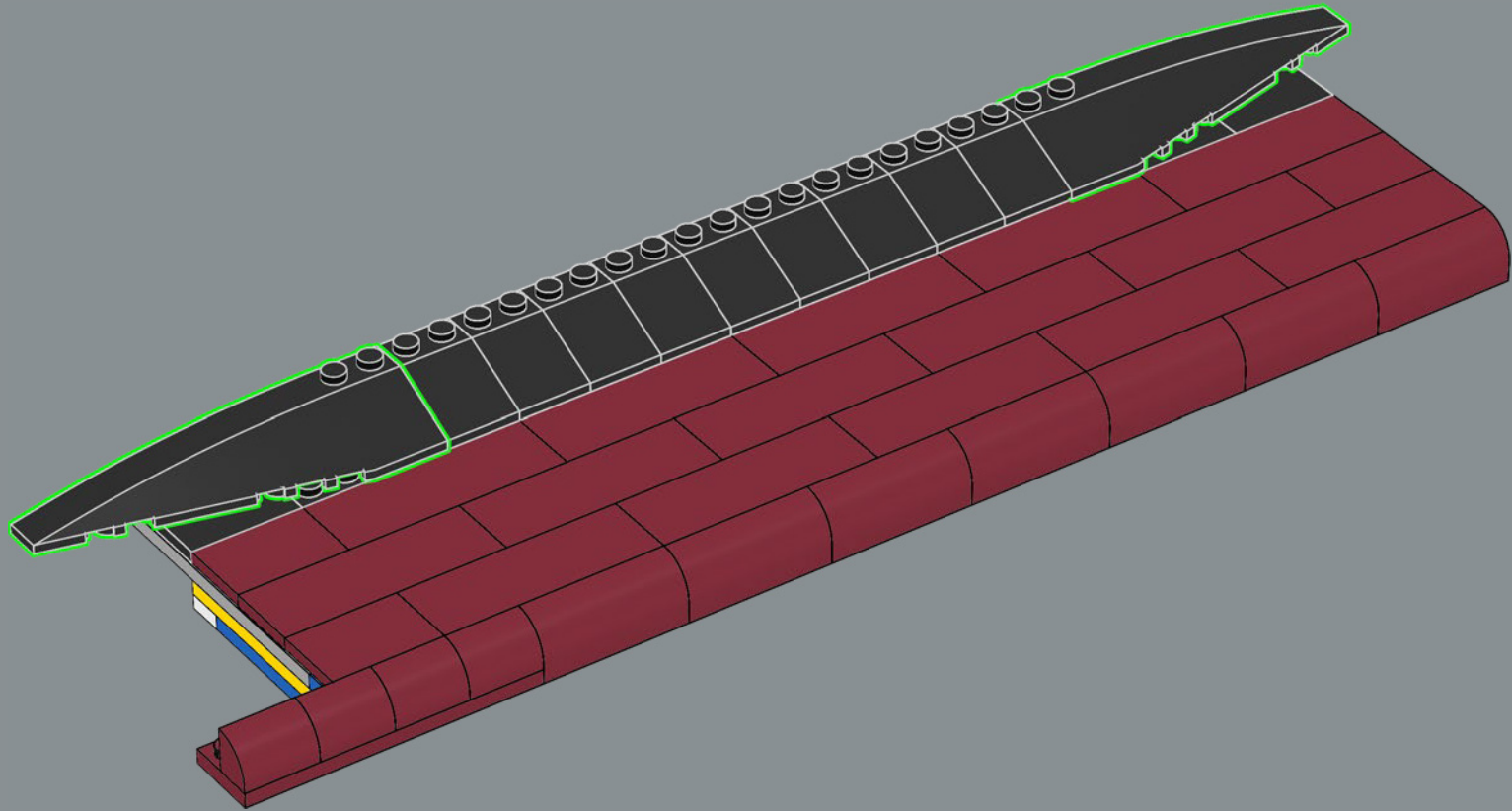

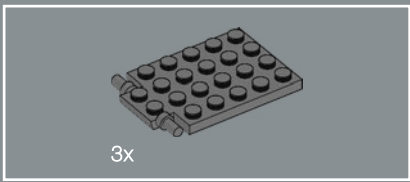

333

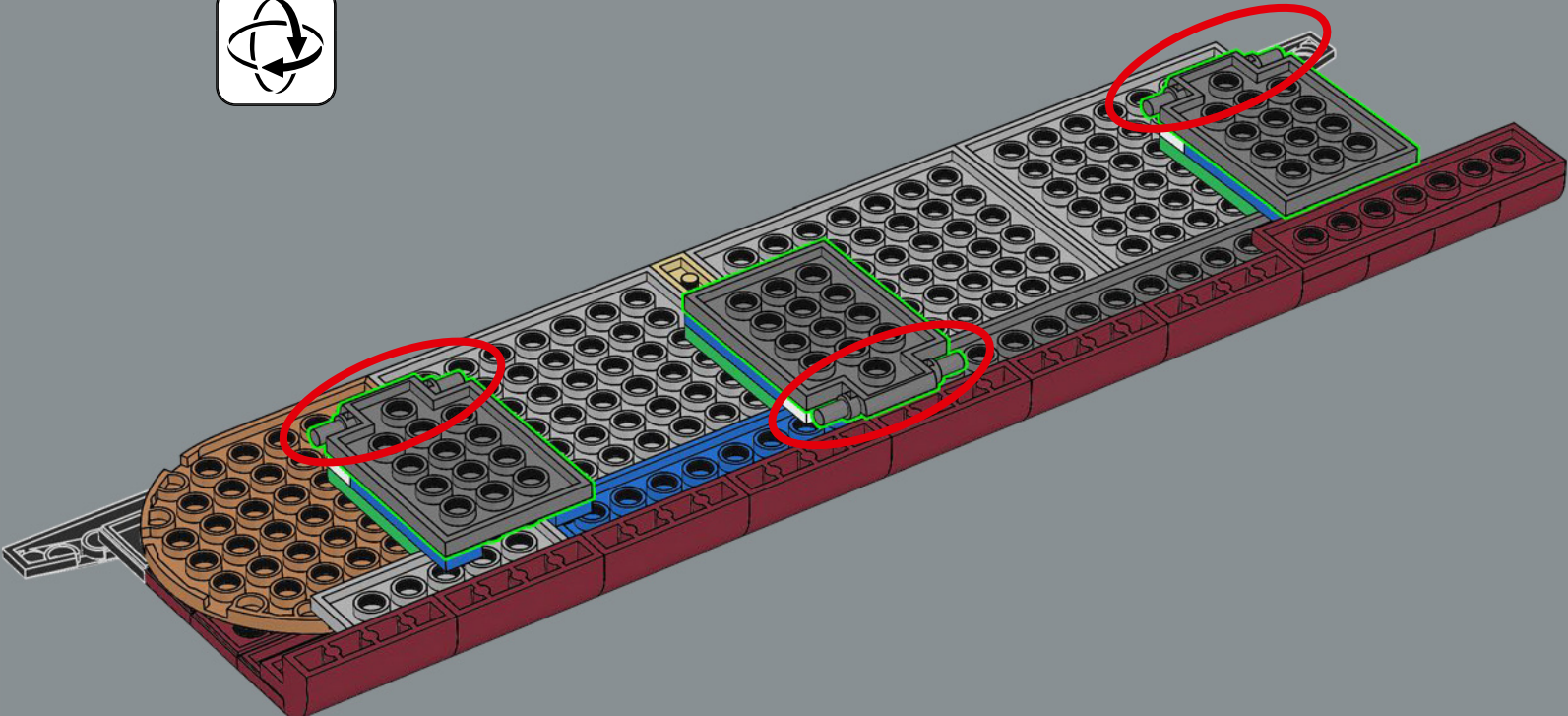



334

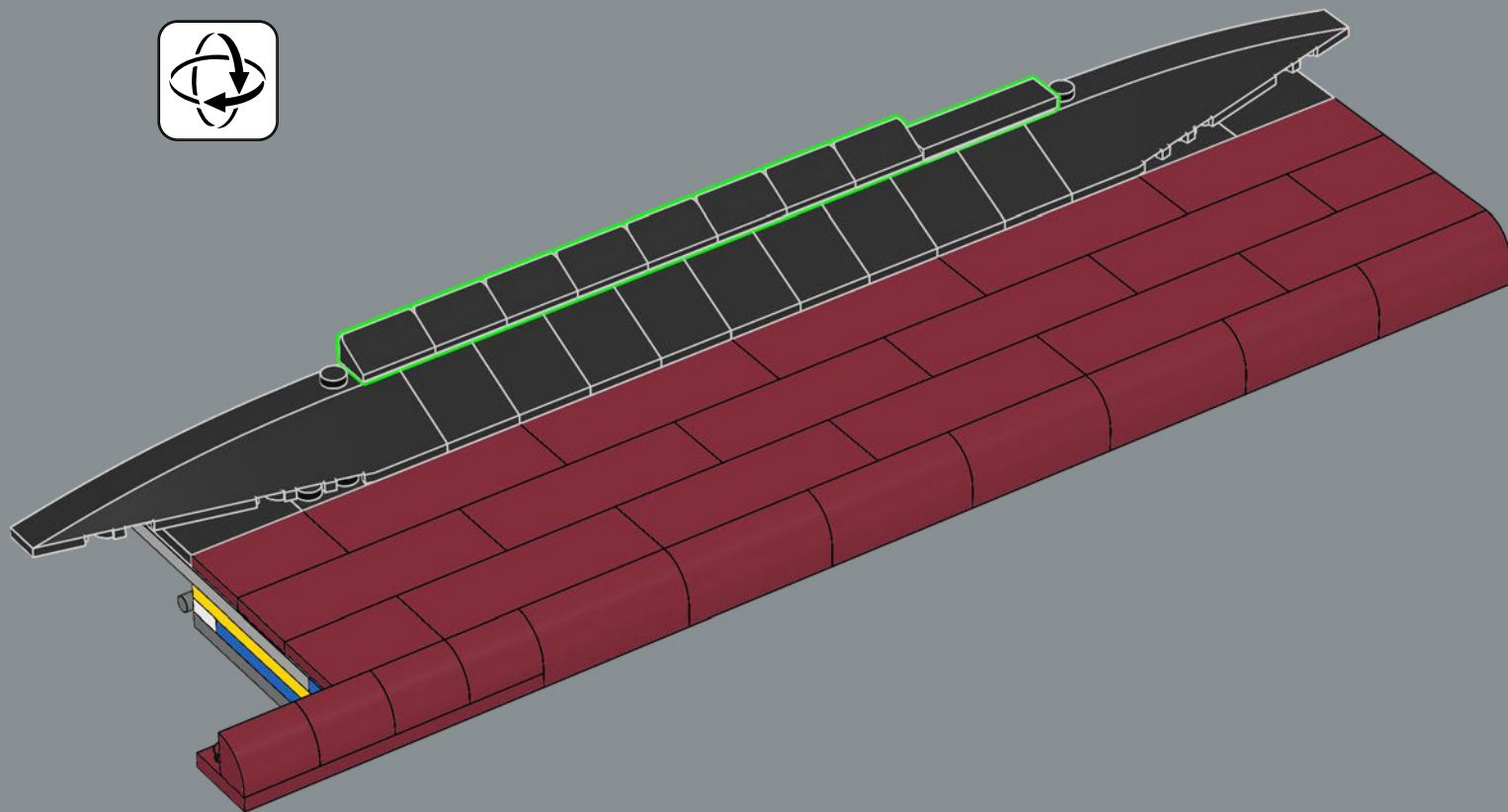

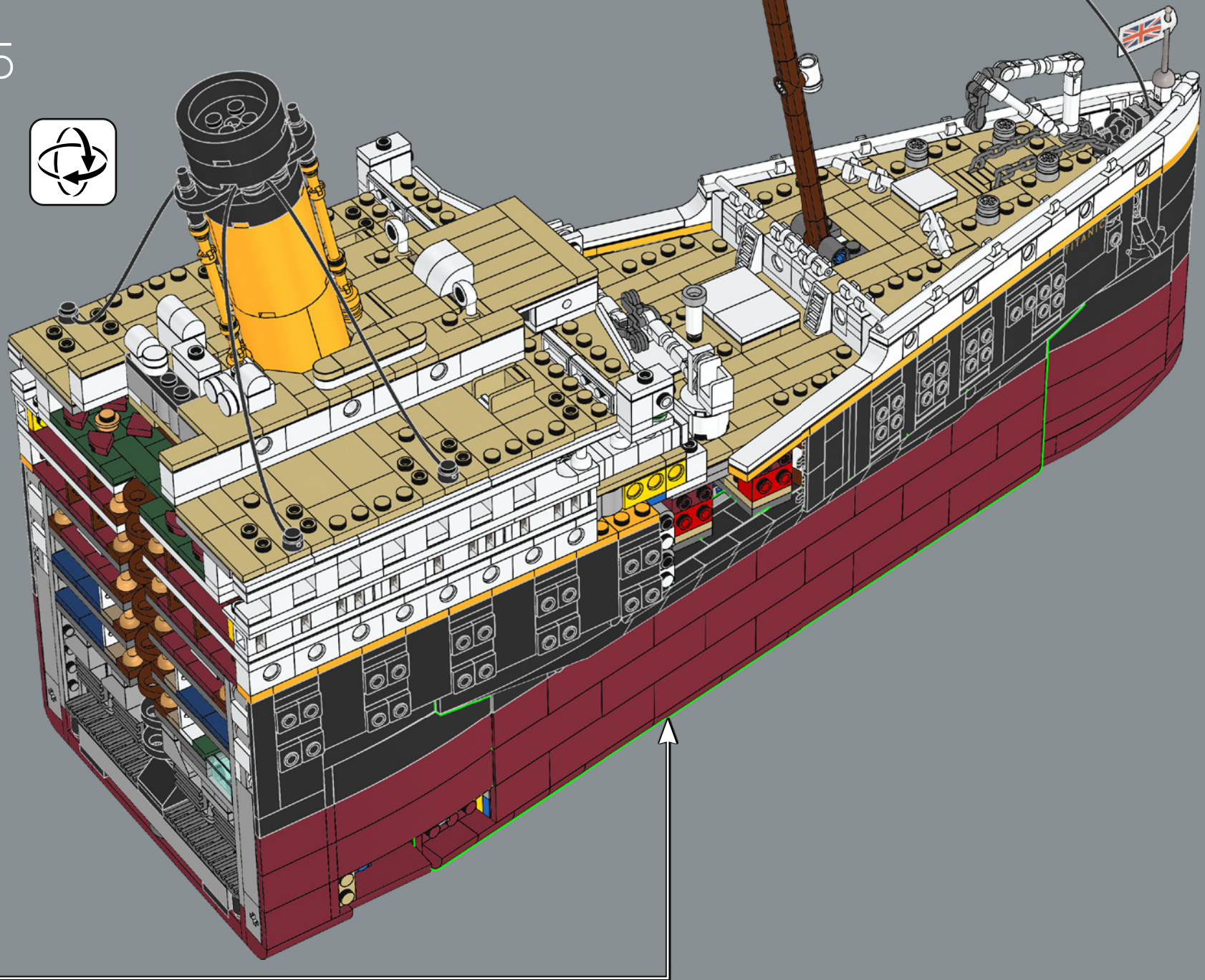



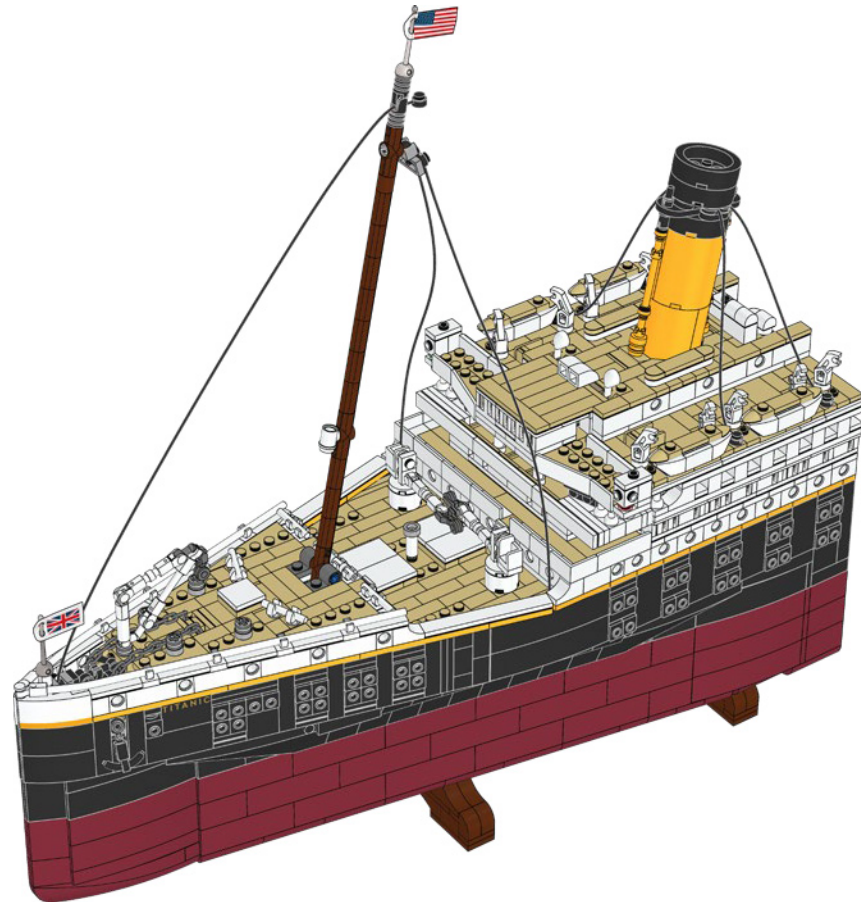
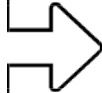

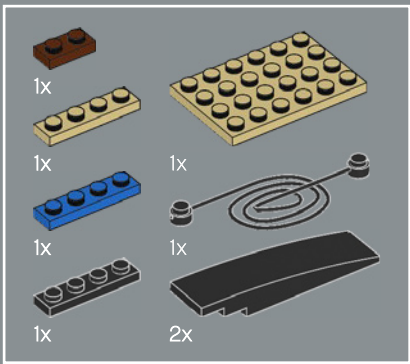

336

1

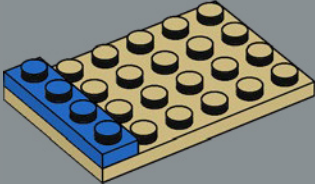

2

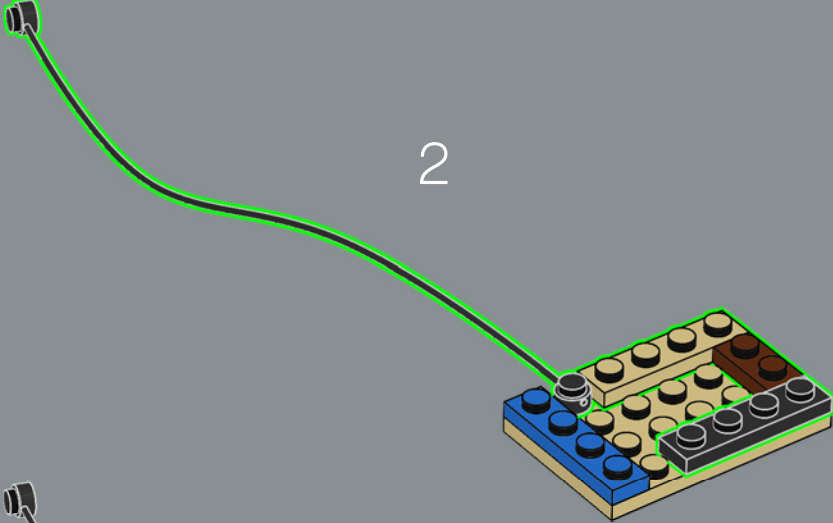

3

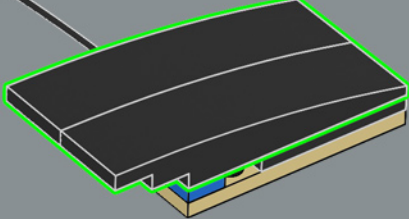

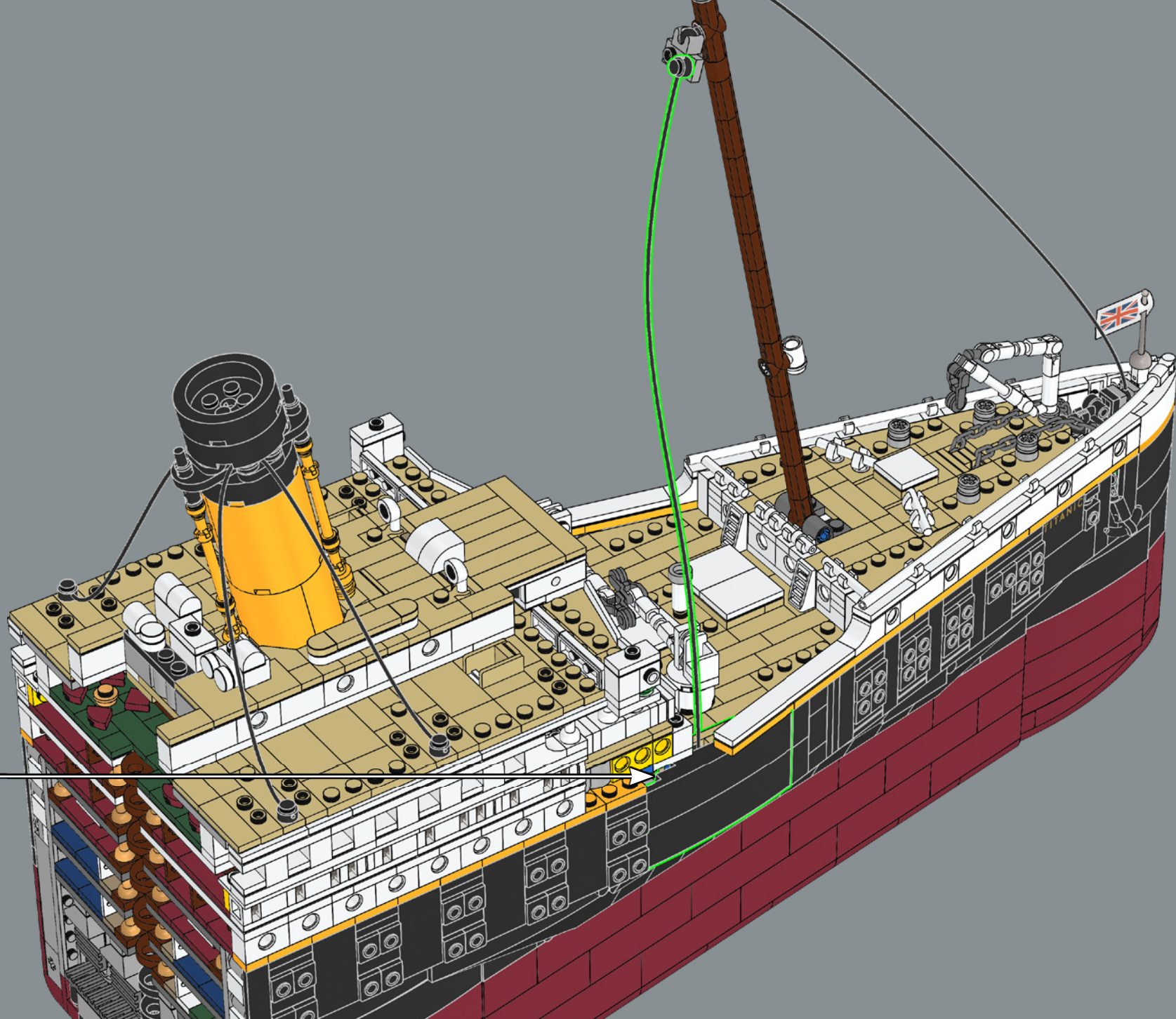

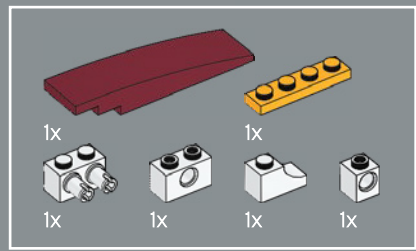

337

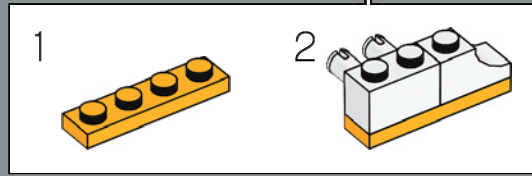
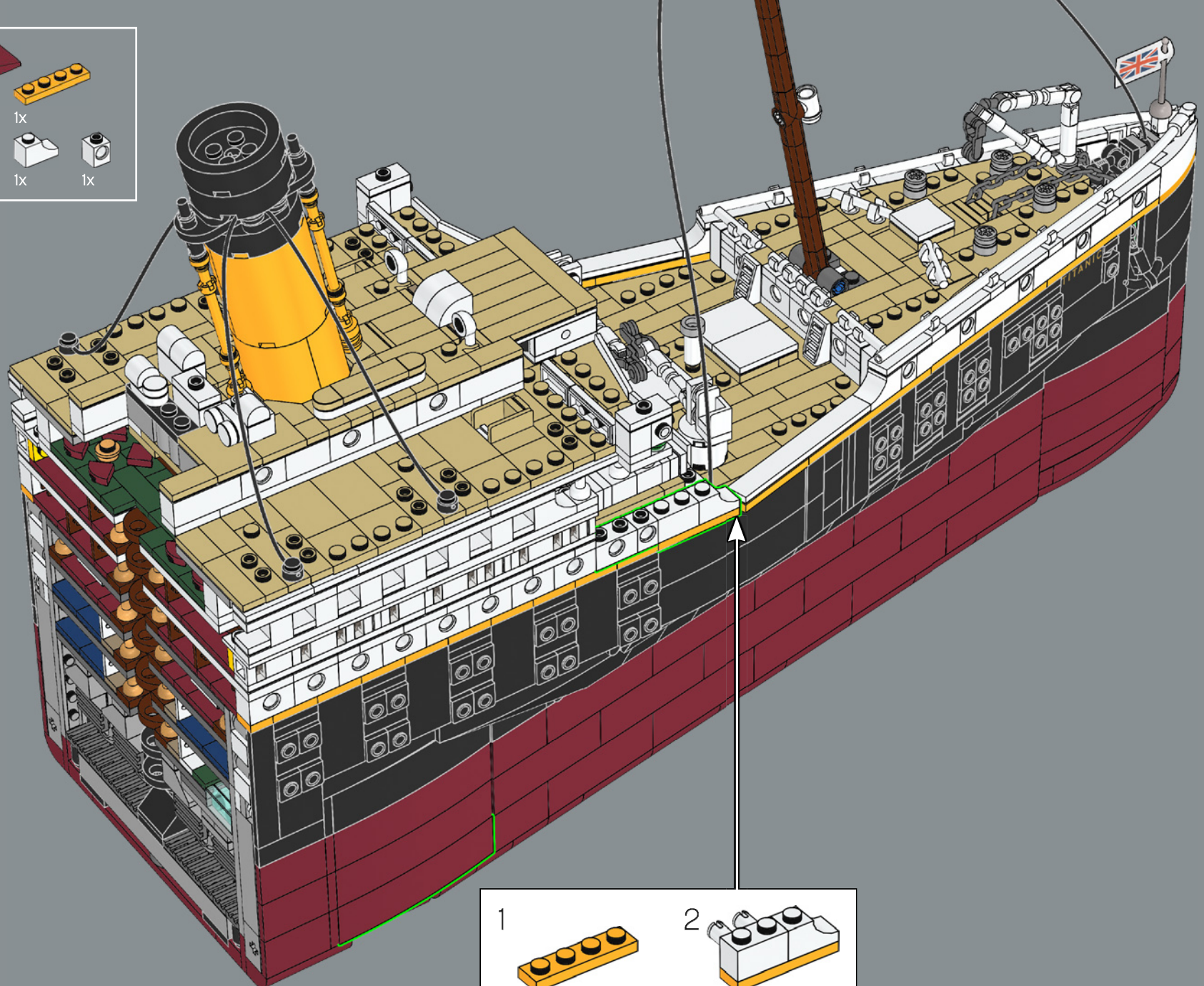



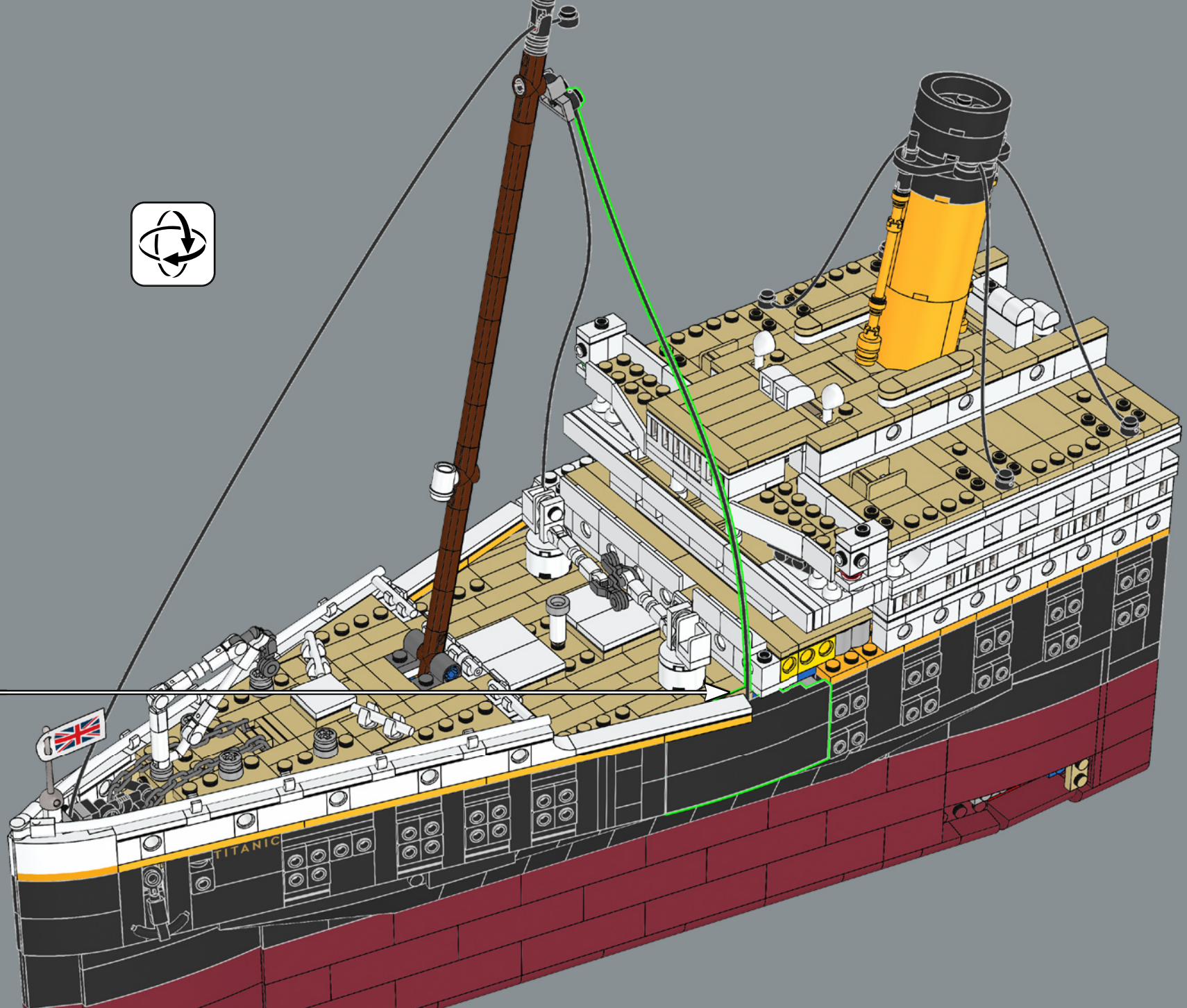

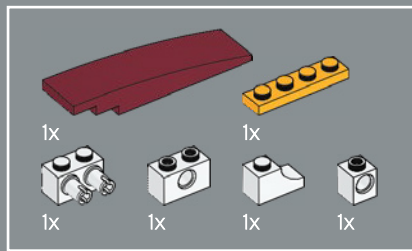

339

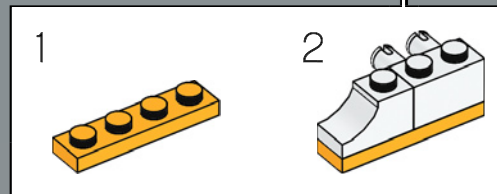
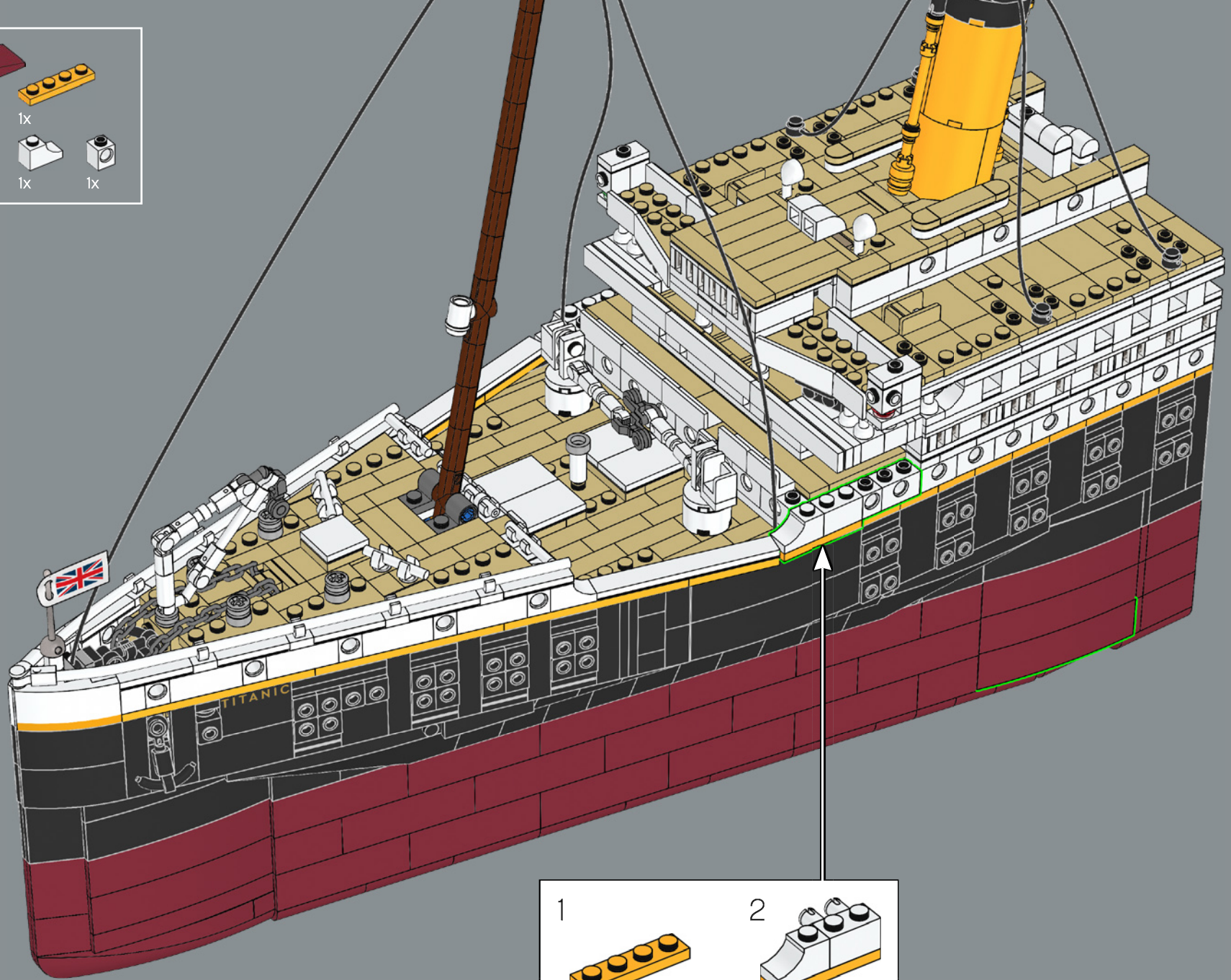

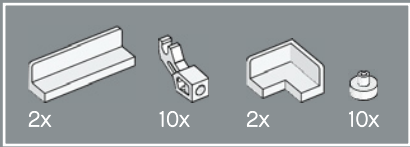

340

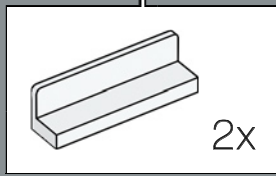
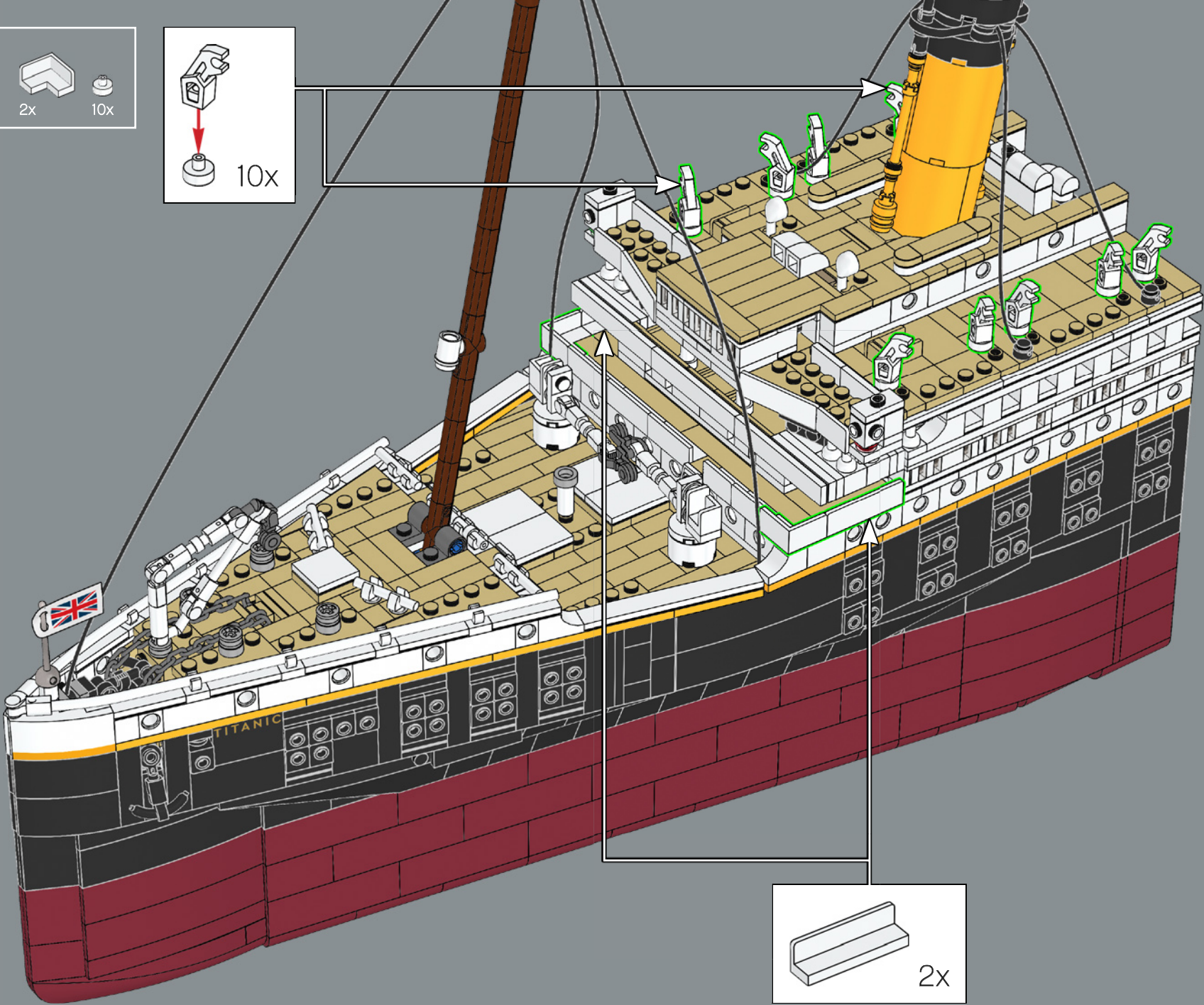
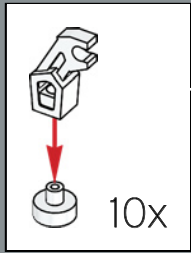





341

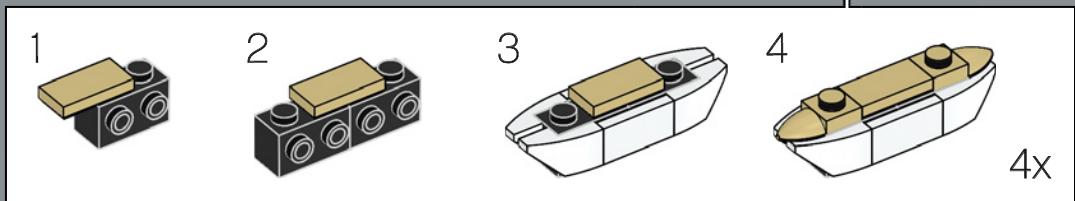
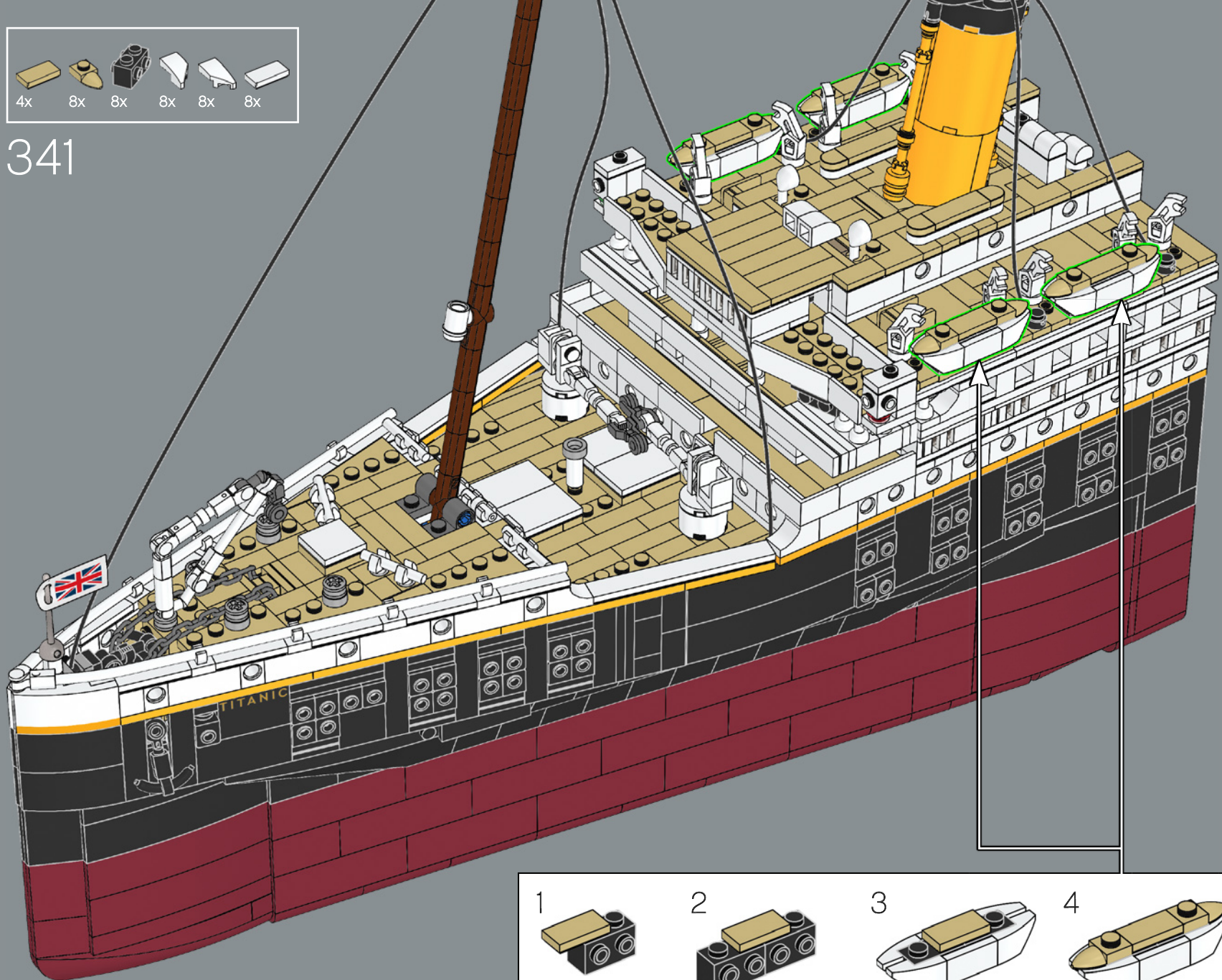

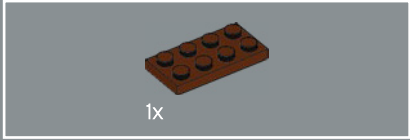
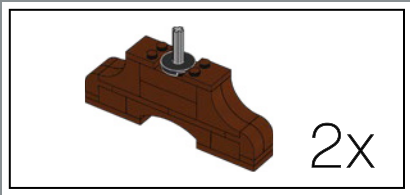

342

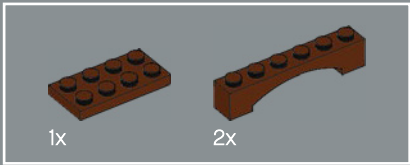
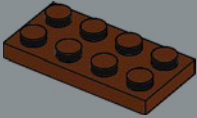

343

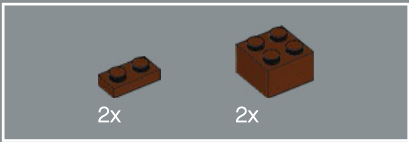
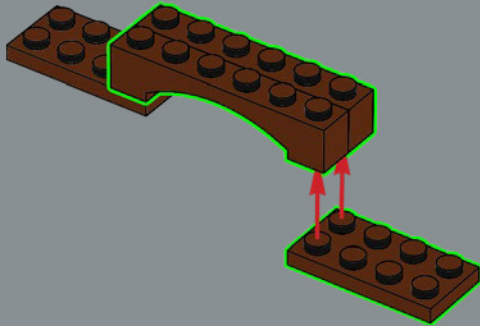

344

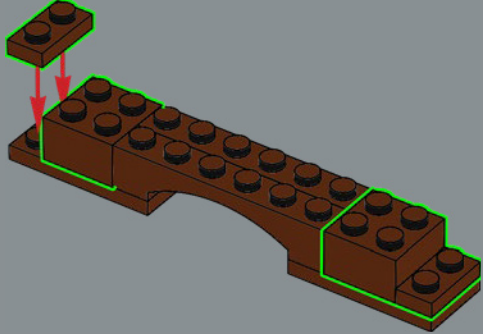

345

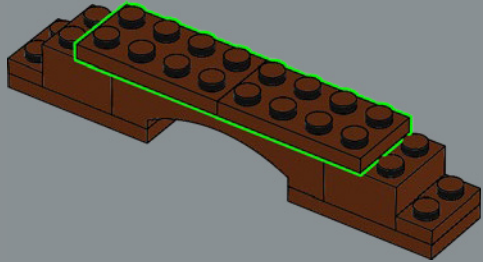

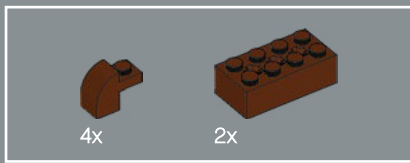

346

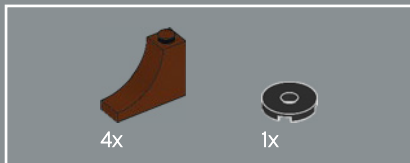
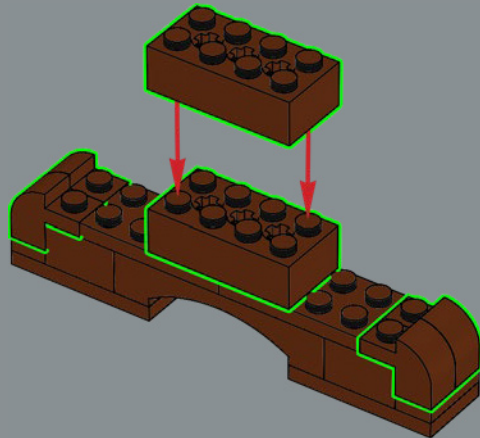

347

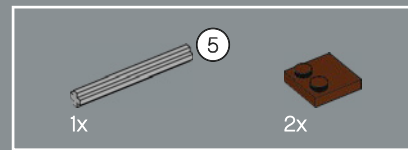
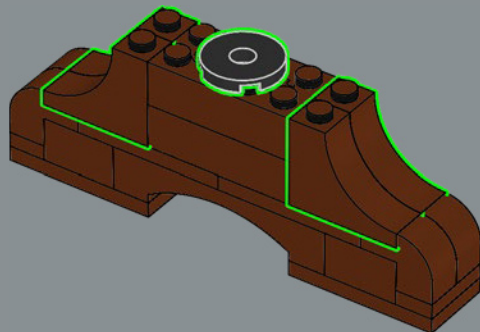

348

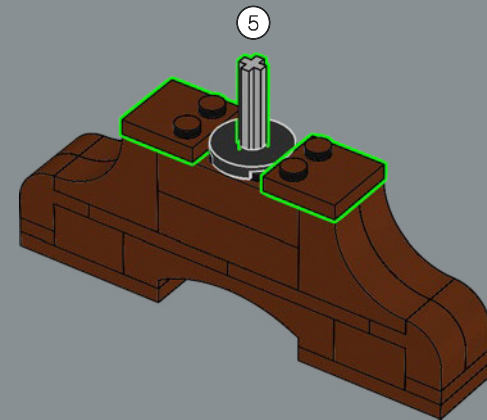
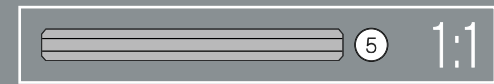

2x

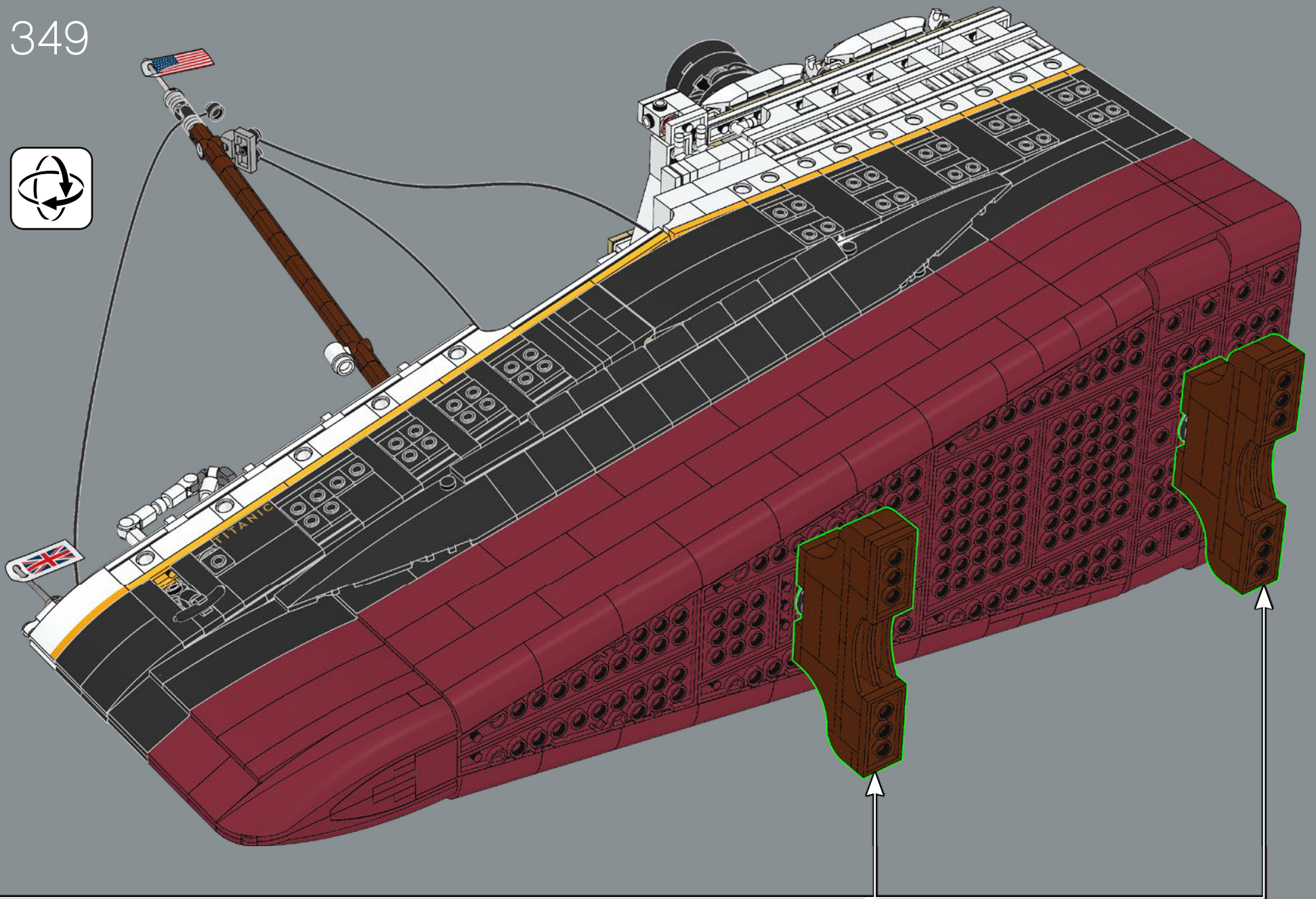

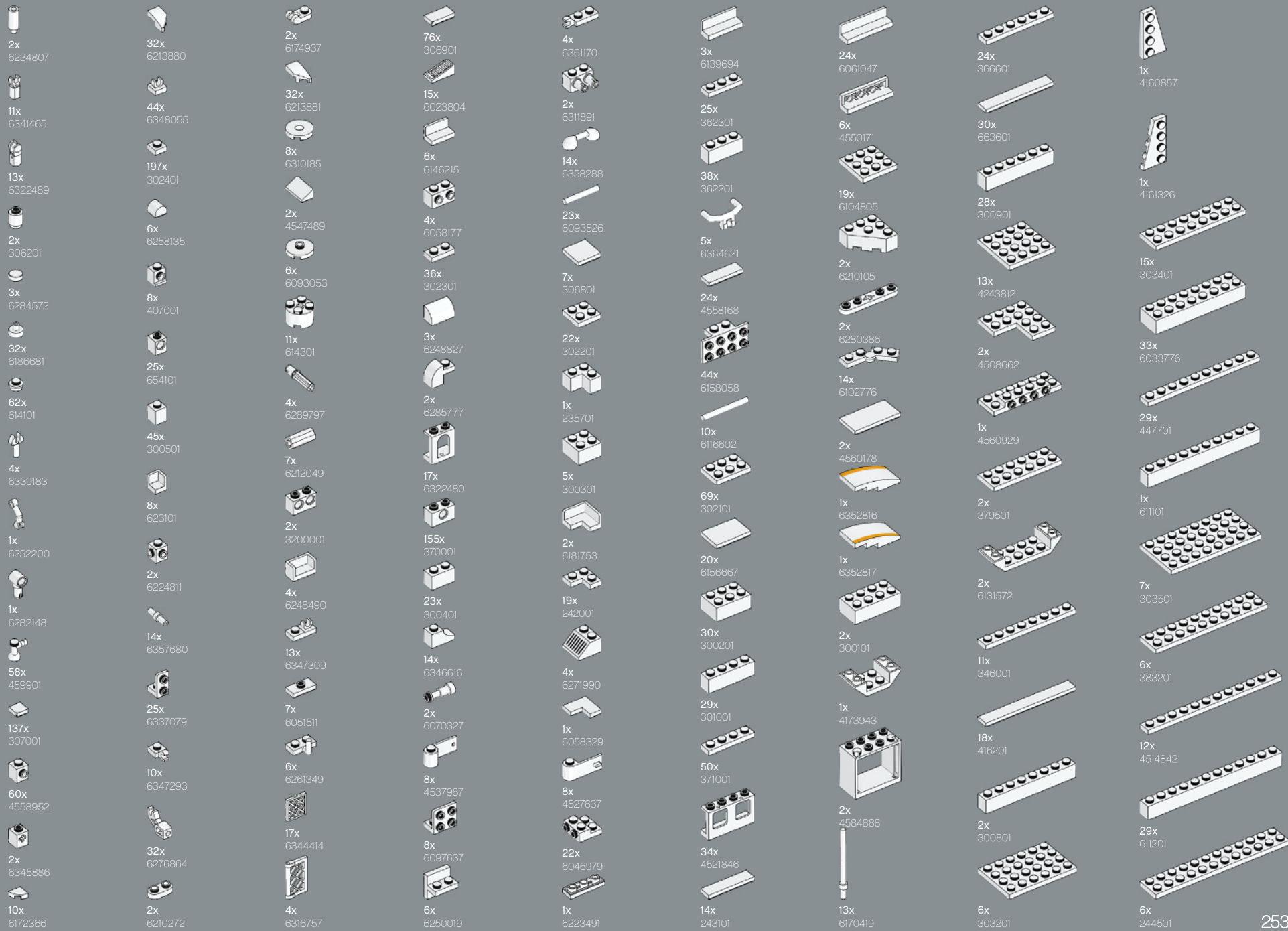

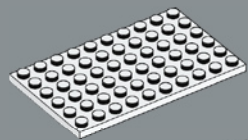

5x  
4528341

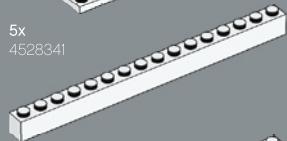

6x  
246501



13x  
4119227



2x  
6365707

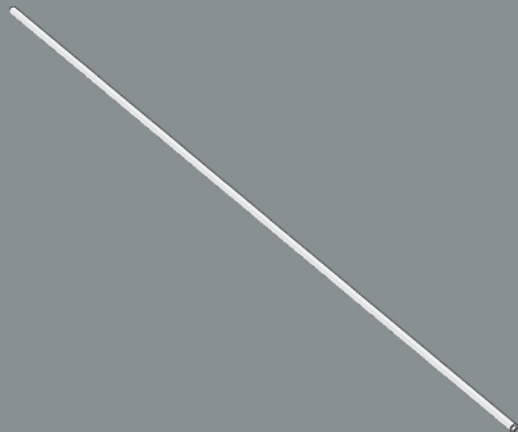

1x  
6364683



1x  
6370720



4x  
6353196



44x  
4118793



83x  
6360078



2x  
4113915



5x  
4179771



54x  
4125253



10x  
4516055



20x  
4159553



2x  
4612603



2x  
6357613



32x  
4224793



4x  
6355727



6x  
6351413



14x  
6352222



8x  
6177890



8x  
6177891



4x  
4624086



4x  
6232037



50x  
4218749



41x  
6092587



2x  
6338180



4x  
6148262



6x  
4109995



6x  
6146221



2x  
6024495



13x  
4205107



1x  
6063943



2x  
6294481



2x  
6103001



153x  
4114026



21x  
4113917



20x  
6034929



2x  
4273526



2x  
6214334



4x  
6117975



4x  
6249809



10x  
6174925



5x  
6253003



2x  
6314477



2x  
6358290



2x  
6358289



1x  
4565387



39x  
4185177



44x  
6221467



44x  
4114084



47x  
6173057



18x  
4114077



16x  
6265572



4x  
6211975



96x  
6131896



14x  
4121921



2x  
4624088



34x  
6211966



2x  
6318084



8x  
4118790



9x  
6175367



2x  
4500453



5x  
4666999



2x  
4113233



12x  
4550324



26x  
6257600



2x  
6195544



2x  
6115031



2x  
4208072



33x  
4114309



53x  
6122047



8x  
6351905



2x  
4112982



10x  
4157277

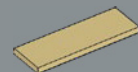

3x  
6331158



4x  
4113993



5x  
4181134



49x  
4114324



11x  
4544139



12x  
4159774



2x  
4114001



2x  
4125217



2x  
4166138



3x  
4509897

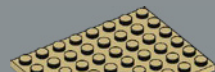

4x  
6070501



6x  
6093864



6x  
6284574



2x  
306221



8x  
654121



10x  
6345429



1x  
6210269



46x  
4142865



2x  
6168634



4x  
6019155



1x  
6265697



22x  
302321



2x  
245821



2x  
6313831



2x  
6313831



2x  
6313831

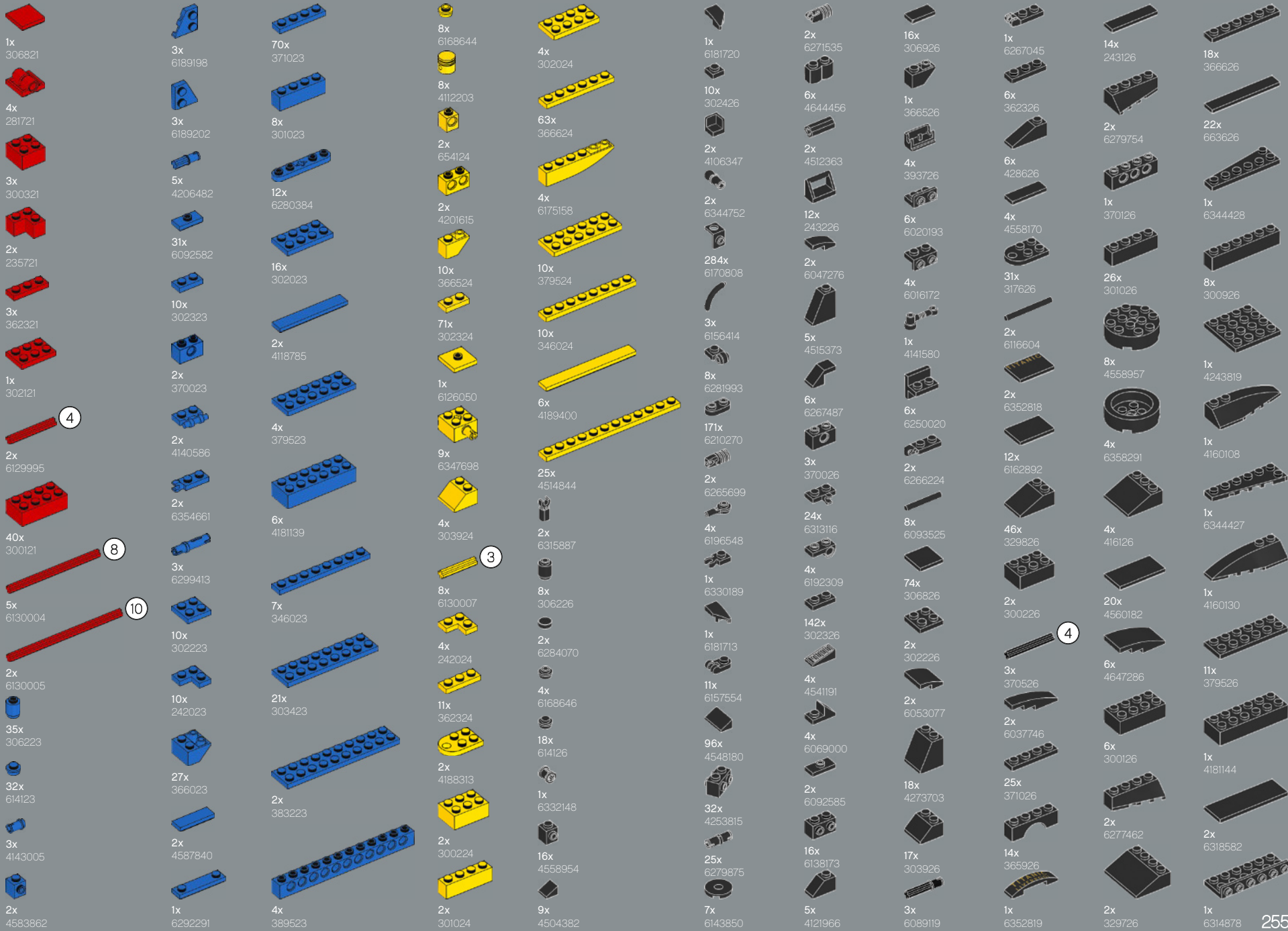

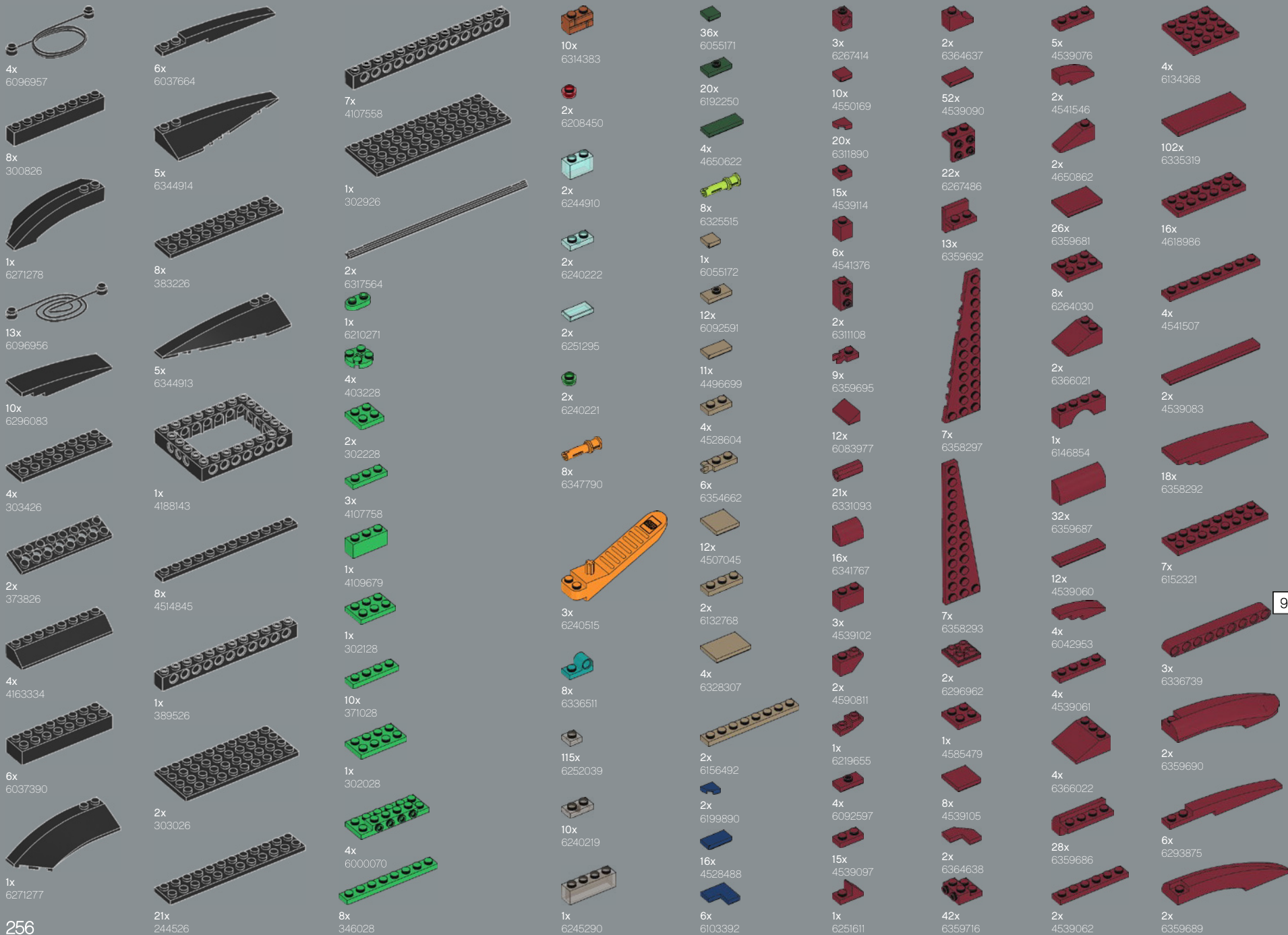

4x  
6096957

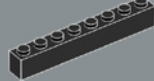

8x  
300826



1x  
6271278



13x  
6096956



10x  
6296083



4x  
303426



2x  
373826

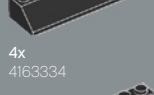

4x  
4163334



6x  
6037390



1x  
6271277



6x  
6037664

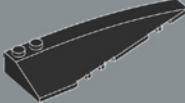

5x  
6344914

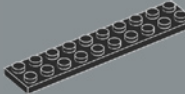

8x  
383226



5x  
6344913

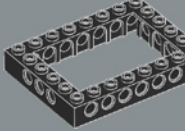

1x  
4188143



8x  
4514845



1x  
389526

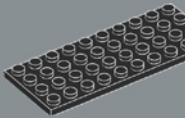

2x  
303026

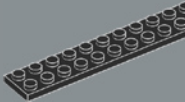

21x  
244526



7x  
4107558

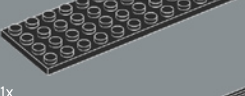

1x  
302926



2x  
6317564



1x  
6210271



4x  
403228



2x  
302228



3x  
4107758



1x  
4109679



1x  
302128



10x  
371028



1x  
302028



4x  
6000070



8x  
346028



10x  
6314383



2x  
6208450



2x  
6244910



2x  
6240222



2x  
6251295



2x  
6240221



8x  
6347790



3x  
6240515



8x  
6336511



115x  
6252039



10x  
6240219



1x  
6245290



36x  
6055171



20x  
6192250



4x  
4650622



8x  
6325515



1x  
6055172



12x  
6092591



11x  
4496699



4x  
4528604



6x  
6354662



12x  
4507045



2x  
6132768



4x  
6328307



2x  
6156492



2x  
6199890



16x  
4528488



6x  
6103392



3x  
6267414



10x  
4550169



20x  
6311890



15x  
4539114



6x  
4541376



2x  
6311108



9x  
6359695



12x  
6083977



21x  
6331093



16x  
6341767



3x  
4539102



2x  
4590811



1x  
6219655



4x  
6092597



15x  
4539097



1x  
6251611



2x  
6364637



52x  
4539090



22x  
6267486



13x  
6359692



7x  
6358297



7x  
6358293



2x  
6296962



1x  
4585479



8x  
4539105



2x  
6366022



2x  
6366022



8x  
4539105



2x  
6364638



42x  
6359716



5x  
4539076



2x  
4541546



2x  
4650862



26x  
6359681



8x  
6264030



2x  
6366021



1x  
6146854



32x  
6359687



12x  
4539060



4x  
6042953



4x  
4539061



4x  
6366022



28x  
6359686



2x  
4539062

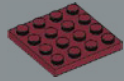

4x  
6134368

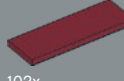

102x  
6335319

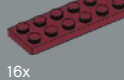

16x  
4618986



4x  
4541507



2x  
4539083

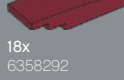

18x  
6358292



7x  
6152321



3x  
6336739

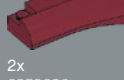

2x  
6359690



6x  
6293875



2x  
6359689



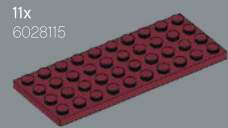
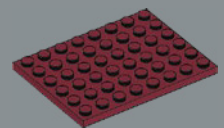

8x  
6186106



8x  
6245265



16x  
6134252



8x  
6223719



16x  
6331261



6x  
6073040



6x  
6028736



91x  
6097503



16x  
6358295



16x  
6020073



4x  
6359223



12x  
6020074



9x  
6192205

6x  
4211183



19x  
4216581



1x  
6170813



2x  
6149677



12x  
4221744



26x  
4211288



46x  
4225469



4x  
6325717



29x  
4531751



2x  
4211222



1x  
4211252



14x  
6365885



105x  
4211150



24x  
6335567



1x  
4211151



10x  
6365884



24x  
4645103



39x  
6236915



20x  
6196221



30x  
4211210



10x  
6365883



5x  
6333110



6x  
4211220



20x  
4211152



24x  
6133833



9x  
6172636



30x  
4211186



14x  
6365882



1x  
4221590



18x  
4211193



12x  
4655611



1x  
4216615



6x  
6313736

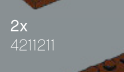

2x  
4211211

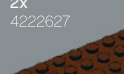

2x  
4222627



1x  
6338230

88x  
4211412

23x  
6258831

7x  
6171165

1x  
4211483

3x  
4558953



12x  
4211399

2x  
6225242

2x  
6345639

8x  
6335378

8x  
4211375

8x  
6227897

4x  
4568637

2x  
6352979

2x  
6352983

1x  
6352986

1x  
6352997

1x  
6353001

155x  
4550325

2x  
6372076

16x  
6093859

4x  
6327412

9x  
6338165

2x  
4211564

20x  
4211398

8x  
4211414

8x  
4211440

10x  
6206249

1x  
6326078

8x  
6146300

8x  
6146300

8x  
4211363

4x  
4211494

2x  
4211614

4x  
6117967

6x  
4654580

8x  
4211609

4x  
6337268

4x  
6078211

4x  
6198932

4x  
4667578

4x  
4211461

4x  
4211632

4x  
6321743

4x  
4208988

1x  
4208988

1x  
4208988

1x  
4208988

1x  
4208988

1x  
4208988

1x  
4208988

1x  
4208988

1x  
4208988

1x  
4208988

1x  
4208988

1x  
4208988

1x  
4208988

1x  
4208988

1x  
4208988

8x  
4211397

46x  
6212077

6x  
6007894

6x  
4234535

4x  
4211815

4x  
6078212

8x  
6195471

1x  
6346487

4x  
6326483

1x  
6304930

15x  
6211969

8x  
4211419

11x  
4211773

30x  
4211396

1x  
4211386

9x  
4211394

1x  
4211441

2x  
4211445

26x  
4211636

8x  
6230229

2x  
4211361

2x  
4211395

8x  
4211385

6x  
4211639

4x  
6256117

8x  
6105964

6x  
4211393

6x  
4211393

16x  
4211438

2x  
4612621

2x  
4211837

2x  
4527174

4x  
6015349

35x  
4211452

13x  
4211795

4x  
6225219

4x  
4211425

2x  
4211442

3

5

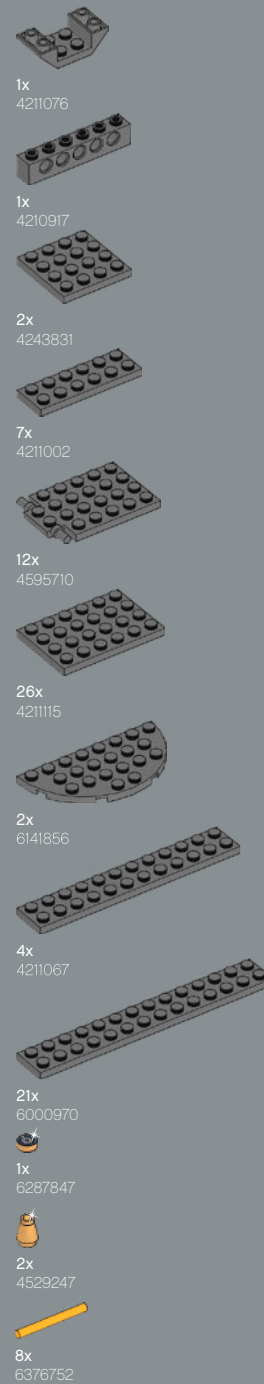
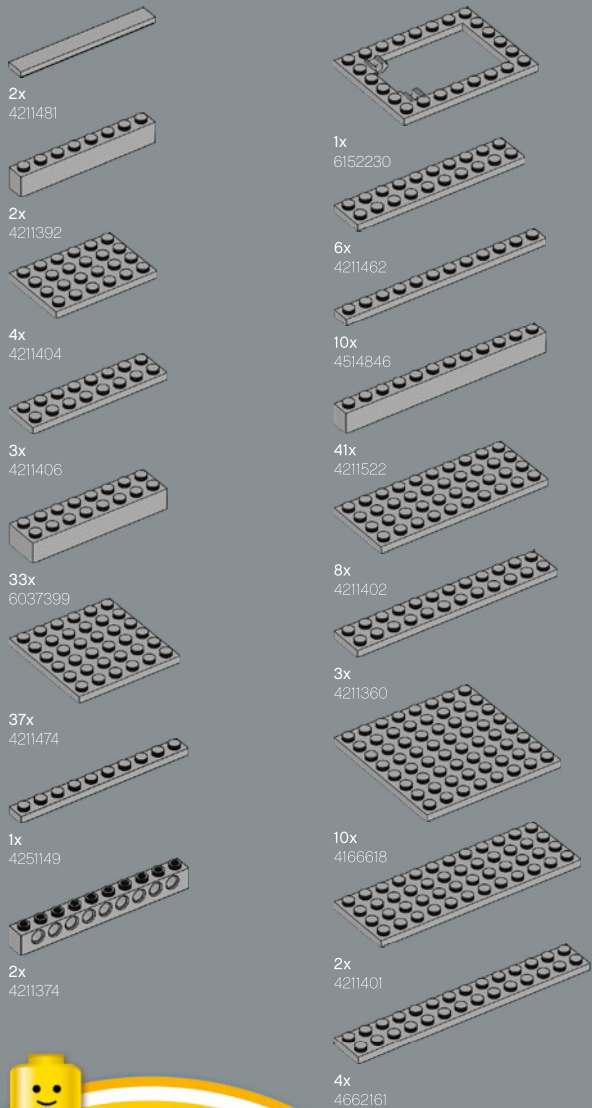

Customer Service  
Kundenservice  
Service Consommateurs  
Servicio Al Consumidor

LEGO.com/service or dial





# FEEDBACK AND WIN



## FEEDBACK AND WIN

Your feedback will help shape the future development of this product series.

Please visit:

## FEEDBACK UND GEWINNEN

Dein Feedback trägt zur Weiterentwicklung dieser Produktreihe bei.

Geh auf:

## COMMENTEZ ET GAGNEZ

Vos commentaires nous aideront à concevoir les futurs produits de cette gamme.

Rendez-vous sur :

## COMENTA Y GANA

Tu opinión nos ayudará a dar forma al desarrollo de esta serie de productos en el futuro.

Visita:

## 反馈有奖

您的反馈将有助于我们在今后改进本系列产品。

请访问：

[LEGO.com/productfeedback](https://www.lego.com/productfeedback)

By completing, you will automatically enter a drawing to win a LEGO® set.

Terms & Conditions apply.

Durch Ausfüllen nimmst du automatisch an der Verlosung eines LEGO® Preises teil.

Es gelten die Teilnahmebedingungen.

En envoyant vos commentaires, vous serez automatiquement inscrit(e) à un tirage au sort qui vous permettra de remporter un prix LEGO®.

Offre soumise à conditions.

Al contestar, participarás automáticamente en el sorteo y podrás ganar un set LEGO®.

Sujeto a Términos y Condiciones.

完成我们的反馈调查，即可自动进入抽奖环节，赢取乐高®套装。

适用《条款和条件》。

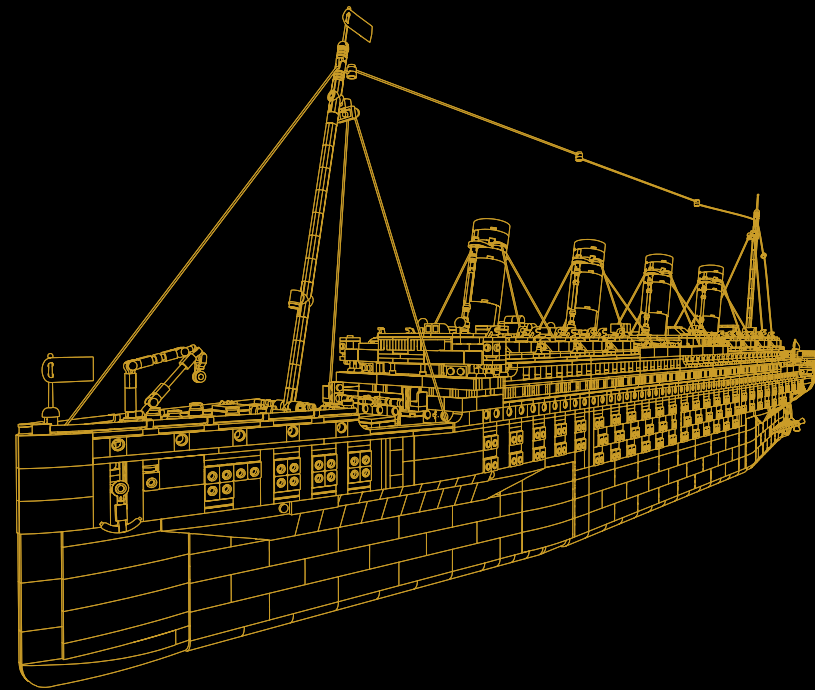

LEGO and the LEGO logo are trademarks of the LEGO Group. ©2021 The LEGO Group.